

SPECIFICATIONS



Model Number: PT2B3
Part Number: 19028254A

Apr. 01, 2016

Mechanical Drawing:

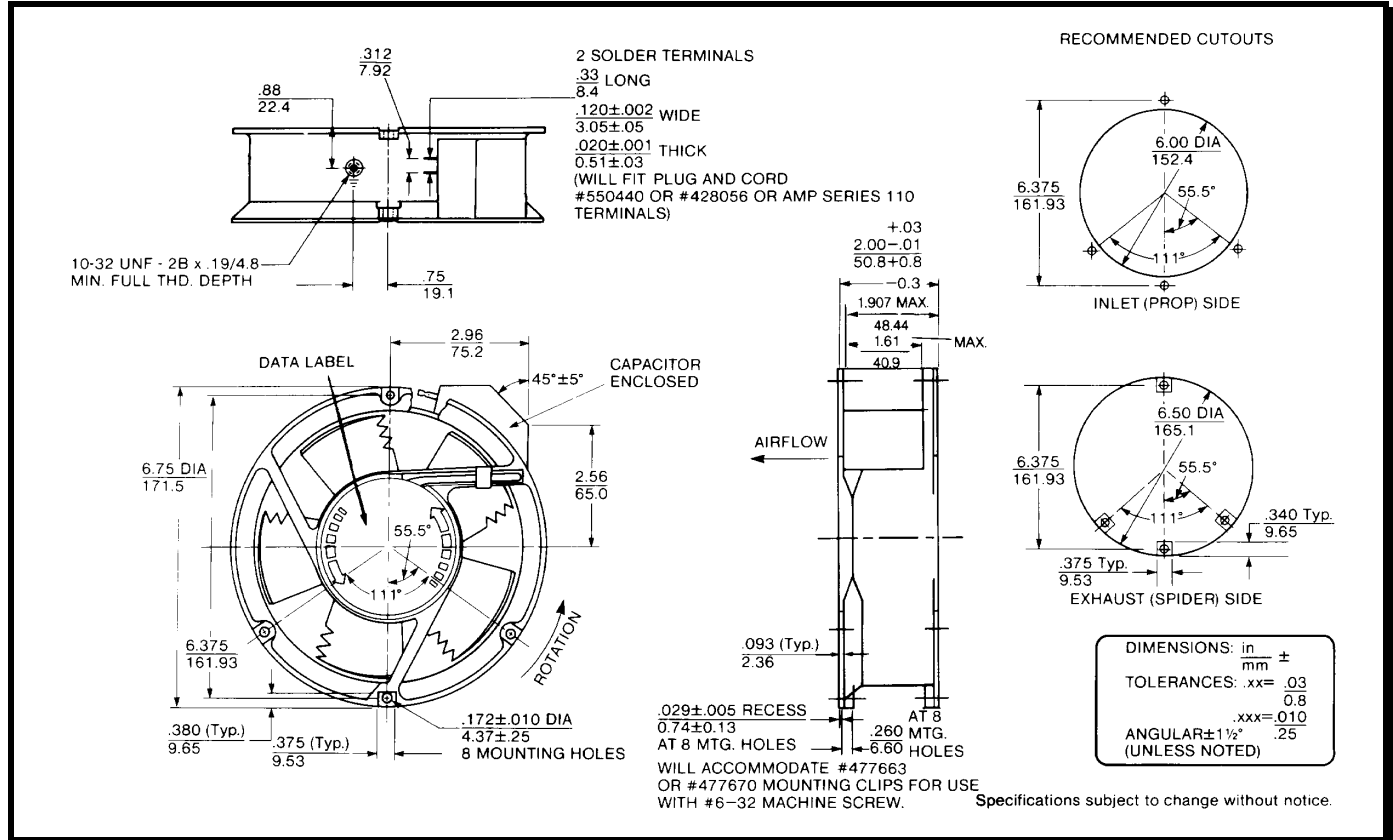

Motor:

Nominal Voltage	= 115 VAC
Frequency	= 50 / 60 Hz
Nominal Running Current	= 0.270 / 0.260 amps
Max. Locked Rotor Current	= 0.490 amps
Running Power	= 30 / 31 watts
Average Speed	= 2880 / 3400 RPM
Bearings	= Ball
Air Flow	= 200 / 235 CFM
Acoustic	= 50.3 / 54.0 dBA

Construction:

Venturi: Single Piece Die Cast Aluminum, Black.
 Propeller: Plastic, Black, UL 94V-0

Life Expectancy:

This fan is designed for continuous duty life of 54,000 hours at 40°C.

Additional Features:

Permanent Split Capacitor Motor
 Thermal Protection
 Automatic Restart Capability
 Operating Temperature: -10°C to 70°C
 Storage Temperature: -40°C to 85°C

Additional Features:

0.110" Terminals

Agency Approvals:

UL, CE