

878X-X

Counter
Summenzähler
Compteur
Contador
Contatore

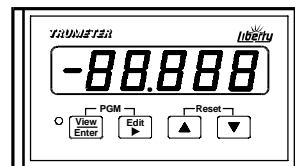

! DIGITAL PANEL METERS

WARNING read page 2 first!

| | |
|--|----|
| Mounting, Montage, Montaje, Montaggio | 9 |
| Connections, Anschlüsse, Raccordements, Conexiones, Collegamenti | 10 |
| Specification, Spezifikation, Caractéristiques, Especificaciones, Specifiche | 14 |
| Operation | 20 |
| Examples | 27 |
| Run mode | 32 |
| Program mode | 34 |
| Function codes | 36 |
| Diagnostics | 42 |

! DIGITALE EINBAU-MESSINSTRUMENTE

ACHTUNG: Lesen Sie zuerst Seite 3!

Betrieb, Programmierung, Diagnose Siehe CD

! INDICATEURS NUMERIQUES DE TABLEAU RECOMMANDATION IMPORTANTE:

Reportez-vous tout d'abord à la page 4!

Fonctionnement, Programmation, Diagnostique consulter le CD

! INSTRUMENTOS DE MEDIDA PANEL DIGITAL

ATENCIÓN: Primero lea la página 6!

Funcionamiento, Programación, Diagnósticos Con referencia a CC

! MISURATORI DIGITALI A PANNELLO

ATTENZIONE: Leggere prima a pagina 7

Funzionamento, Programmazione, Diagnostica fare riferimento al CD



WARNING

Installation and maintenance must be carried out by suitably qualified personnel only. Hazardous voltages may be present on the connection terminals.

Installation

This product is intended to be installed in accordance with the operating and installation requirements of Overvoltage Category II and Pollution Degree 2 (as defined by IEC 664).

It must be fitted in a suitable enclosure which is accessible to qualified personnel only.

An external supply fuse must be fitted. The recommended fuse is:

DC supply - S504-2A manufactured by Bussmann.

Fuse details: Antisurge 2A, Rating 50V, Breaking capacity 35A @50V, UL recognised (file no E75865), complies with IEC127.

AC supply - S504-200mA manufactured by Bussmann.

Fuse details: Antisurge 200mA, Rating 250VAC, Breaking capacity 35A @250VAC, UL recognised (file no E75865), complies with IEC127.

The relay output circuits must be fitted with fuses suitable for the voltage and current being switched.

Maximum fuse ratings:

| | | |
|--------|------------------|----------------|
| 250VAC | @ cos ϕ = 1 | fuse rating 5A |
| 30VDC | @ cos ϕ = 1 | fuse rating 5A |

All conductors carrying hazardous voltage should have external switching or disconnect mechanisms fitted which provide at least 3mm of contact separation in all poles.

Failure to install or operate the unit in accordance with the above requirements may result in the electrical safety of the unit being impaired.



Maintenance

Ensure that all power sources to the unit are isolated prior to maintenance, inspection or cleaning.

There are no user serviceable parts inside this unit. Under no circumstances should the case be opened.

All external wiring connections should be inspected at regular intervals. Any damaged wiring should be replaced and any loose connections should be retightened.

Cleaning should be carried out using a dry cloth to wipe the casing of the unit.



Programming

Caution: If the optional relay output and/or analog output board(s) are installed in the DPM, then entering Program mode will cause both relays to release and the analog output to go to its minimum value (0V or 4 mA) regardless of the input signal value.



Diagnostics

Caution: Performing the diagnostic tests will turn on the analog output and operate the relays if those options are installed. First remove power from the DPM and disconnect the outputs from any loads that should not be turned on. If the optional RS485 communication board is installed, the DPM will respond with the scaled input value to the QST command.



ACHTUNG

INSTALLATION UND WARTUNG DÜRFEN NUR VON ENTSPRECHEND GESCHULTEN MITARBEITERN VORGENOMMEN WERDEN. AN DEN ANSCHLUSSKLEMMEN KÖNNEN LEBENSGEFÄHRLICHE HOCHSPANNUNGEN ANLIEGEN.

Installation

Dieses Produkt ist gemäss den Betriebs- und Installationsanforderungen von Schutzklasse II und Funkstörklasse 2 (entsprechend der Definition durch IEC 664) zu installieren.

Es muss in einem geeigneten Schutzbereich aufgestellt werden, der nur für entsprechend geschulte Mitarbeiter zugänglich ist.

In die externe Versorgung muss eine Sicherung eingesetzt werden. Empfohlen werden Sicherungen vom:

Versorgung DC - S504-2A, zB hergestellt von Bussmann.

Kenndaten der Sicherung: Absicherung gegen Stromspitzen 2A, Sicherungsbemessung 50V, Ausschaltleistung 35A bei 50VAC, anerkannt durch UL (Aktenzeichen E75865), entspricht IEC127.

Versorgung AC - S504-200mA, zB hergestellt von Bussmann.

Kenndaten der Sicherung: Absicherung gegen Stromspitzen 200mA, Sicherungsbemessung 250VAC, Ausschaltleistung 35A bei 250VAC, anerkannt durch UL (Aktenzeichen E75865), entspricht IEC127.

Die Ausgangsschaltkreise des Relais müssen mit geeigneten Sicherungen entsprechend den geschalteten Spannungen und Strömen versehen werden.

Maximale Sicherungsnennwerte:

| | | |
|--------|------------------|-----------------------|
| 250VAC | @ cos ϕ = 1 | Sicherungsnennwert 5A |
| 30VDC | @ cos ϕ = 1 | Sicherungsnennwert 5A |

Alle Stromleiter, an denen gefährliche Spannungen anliegen, müssen mit externen Schalt- oder Trennvorrichtungen versehen werden, die einen Kontaktabstand von mindestens 3 mm an allen Polen herstellen.

Wenn das Gerät nicht entsprechend den vorstehenden Anforderungen installiert und betrieben wird, ist die elektrische Sicherheit des Geräts nicht gewährleistet.

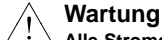

Wartung

Alle Stromquellen des Geräts müssen vor Wartungs-, Inspektions- und Reinigungsmaßnahmen isoliert werden.

Benutzerseitige Maßnahmen an den Teilen im Geräteinneren sind nicht möglich. Das Gehäuse darf unter keinen Umständen geöffnet werden.

Alle externen Kabelverbindungen müssen in regelmäßigen Abständen inspiziert werden. Beschädigte Kabelverbindungen müssen ersetzt und lose Verbindungen nachgezogen werden.

Die Reinigung des Gerätes ist durch Abwischen des Gehäuses mit einem trockenen Tuch vorzunehmen.



Programmierung

Achtung: Falls die Optionskarten Relaisausgang und/oder Analogausgang im DPM installiert sind, so bewirkt das Aufrufen des Programmiermodus, dass beide Relais freigegeben werden und dass der Analogausgang auf seinen Minimumwert (0V oder 4mA) gesetzt wird, unabhängig vom Wert des Eingangssignals.



Diagnose

Achtung: Die Durchführung der Diagnosetests bewirkt das Einschalten des Analogausgangs und des Betriebs der Relais, falls die Optionskarte Relais installiert ist. Zuerst die Versorgung des DPM abschalten und die Ausgänge von allen Lasten abklemmen, die nicht eingeschaltet sein sollen. Falls die Optionskarte Kommunikation RS485 installiert ist, reagiert das DPM auf den Befehl QST mit dem proportionalen Eingangswert.



RECOMMANDATION IMPORTANTE

L'INSTALLATION ET L'ENTRETIEN DOIVENT ETRE REALISES UNIQUEMENT PAR UN PERSONNEL SPECIALEMENT QUALIFIE. DES TENSIONS DANGEREUSES PEUVENT ETRE PRESENTES SUR LES BORNIERES DE RACCORDEMENT.

Installation

Ce produit doit être installé conformément aux normes Surtension Catégorie II et Pollution Niveau 2 de fonctionnement et d'installation (selon les réglementations IEC 664).

Il doit être inséré dans un boîtier adapté uniquement accessible au personnel qualifié.

Une alimentation externe doit être prévue. Le type de fusible recommandé est:

Alimentation CC - S504-2A fabriqué par Bussman.

Détails du fusible : fusible à action temporisée 2A, Calibre 50V, Capacité de coupure 35A @50VCC, homologué UL (fichier n° E75865), en conformité aux réglementations IEC127.

Alimentation CA - S504-200mA fabriqué par Bussman.

Détails du fusible : fusible à action temporisée 200mA, Calibre 250VCA, Capacité de

coupure 35A @250VCA, homologué UL (fichier n° E75865), en conformité aux réglementations IEC127.

Les circuits de sortie de relais doivent être munis de fusibles adaptés aux tensions et courants commutés.

Protection maximale du fusible :

250VCA @ $\cos\phi=1$ Protection du fusible 5A

30VCC @ $\cos\phi=1$ Protection du fusible 5A

Tous les conducteurs avec tension à risques doivent être munis d'interrupteurs externes ou de sectionneurs ayant au moins 3 mm de séparation de contact sur tous les pôles.

L'inobservation des instructions ci-dessus lors de l'installation ou de la mise en service peuvent provoquer des problèmes de sécurité électrique pouvant endommager l'appareil.



Entretien

Veiller à ce que toutes les tensions d'alimentation de l'appareil soient isolées avant d'effectuer des travaux de maintenance, d'inspection ou de nettoyage.

Aucune pièce de cet appareil n'est réparable par l'utilisateur. Le boîtier ne doit pas être ouvert, sous aucun prétexte.

Tous les branchements extérieurs doivent être inspectés à intervalles réguliers. Tout fil endommagé doit être remplacé et toutes les connexions desserrées doivent être resserrées.

Le nettoyage doit être fait avec un chiffon sec pour dépoussiérer le boîtier de l'unité.



Programmation

Avertissement : Si les carte optionnelles Relais et Sortie analogique sont installées dans le DPM, l'accès au mode Programme provoque le déclenchement des deux relais et les valeurs minimales de la sortie analogique (0V ou 4mA), indépendamment de la valeur du signal d'entrée.



Diagnostic

Avertissement : L'exécution des tests de diagnostic activera la sortie analogique et mettra en marche les relais si ces options sont installées. Avant tout coupez l'alimentation du DPM et débranchez les sorties de toute charge ne devant pas être activée. Si la plaquette de communication RS485 optionnelle est installée, le DPM donnera la valeur entrante réduite à la commande QST.



ATENCIÓN

LA INSTALACION Y EL MANTENIMIENTO DEBE SER EFECTUADO CONVENIENTEMENTE SOLAMENTE POR PERSONAL CAPACITADO. PUEDEN HABER VOLTAJES PELIGROSOS EN LOS TERMINALES DE CONEXION.

Instalación

Este producto está destinado para ser instalado de acuerdo con los requerimientos de operación e instalación de la Categoría II de Sobrevoltaje y Grado 2 de Contaminación (como está definido por IEC 664).

Debe ser colocado en un apropiado contenedor al cual tenga acceso solamente personal capacitado.

Hay que montar un fusible de alimentación exterior. El fusible recomendado es:

Alimentación CC - S504-2A fabricado por Bussmann.

Detalles del Fusible: Sobrecorriente 2A, Servicio 50 V, Poder de Interrupción 35A a 50VCC, reconocido por UL (ficha N° E75865), de acuerdo con las normas IEC127.

Alimentación CA - S504-200mA fabricado por Bussmann.

Detalles del Fusible: Sobrecorriente 200 mA, Servicio 250 VAC, Poder de Interrupción 35A a 250VCA, reconocido por UL (ficha N° E75865), de acuerdo con las normas IEC127.

Los circuitos de salida del relé deben estar instalados con fusibles apropiados de acuerdo a los valores máximos de voltaje y corriente que se conmutan.

Máximos valores de los fusibles:

| | | |
|--------|----------------|----------------------|
| 250VCA | @ $\cos\phi=1$ | valor del fusible 5A |
| 30VCC | @ $\cos\phi=1$ | valor del fusible 5A |

Todos los conductores que lleven voltajes peligrosos deben tener instalados mecanismos externos de interrupción o desconexión que provea una separación entre los contactos de por lo menos 3mm en todos los polos.

Podría afectarse la seguridad eléctrica de la unidad si ésta no se instala o se opera de acuerdo a los requerimientos anteriormente mencionados.



Mantenimiento

Asegúrese que todas las fuentes de energía de la unidad estén aisladas con anterioridad al mantenimiento, inspección o limpieza.

No hay ningún componente dentro de esta unidad que pueda repararse por el usuario. Bajo ninguna circunstancia la caja debe ser abierta.

Todas las conexiones del cableado externo deben inspeccionarse periódicamente.

Deben reemplazarse todos los cables dañados y debe ajustarse toda conexión floja.

La limpieza sobre la caja de la unidad debe efectuarse utilizandose un paño seco.



Programación

Atención: Si se ha instalado en el DPM una salida del relé opcional y/o un cuadro(s) de salida analógica, cuando se entre la modalidad programa se producirá el disparo de los dos relés y la salida analógica se pondrá en su valor mínimo (0V o bien 4mA) indiferentemente de cuál sea el valor de la señal de entrada.



Diagnósticos

Atención: Cuando se realicen los tests de diagnóstico se conectará la salida analógica y se accionarán los relés si dichas opciones han sido instaladas. Primero quitar la alimentación del DPM y desconectar las salidas de todas las cargas que pudieran estar conectadas. Si ha sido instalado el cuadro de comunicación opcional RS485, el DPM contestará con el valor de entrada reducido en la señal de mando QST.



ATTENZIONE

L'INSTALLAZIONE E LA MANUTENZIONE DEVONO ESSERE ESEGUITE ESCLUSIVAMENTE DA PERSONALE DEBITAMENTE QUALIFICATO. IN CORRISPONDENZA DEI MORSETTI DI COLLEGAMENTO POTREBBERO ESSERE PRESENTI TENSIONI PERICOLOSE.

Installazione

Il presente prodotto deve essere installato secondo i requisiti di funzionamento e installazione della Categoria di Sovratensione II ed il Grado di Inquinamento 2 (come definito da IEC 664).

L'unità deve essere installata in una idonea custodia, accessibile unicamente al personale qualificato.

E' necessario installare un fusibile di alimentazione esterno:

Alimentazione CC - S504 - 2A prodotto da Bussmann.

Resistenza a sovracorrenti transitorie 2A, tensione 50V, capacità di apertura 35A a 50VCC, omol. UL (reg. n°. E75865), conforme a IEC127.

Alimentazione AC - S504 - 200mA prodotto da Bussmann.

Resistenza a sovracorrenti transitorie 200mA, tensione 250VAC, capacità di apertura 35A a 250VAC, omol. UL (reg. n°. E75865), conforme a IEC127.

I circuiti di uscita a relè devono essere equipaggiati con fusibili compatibili con la tensione e la corrente di commutazione.

Valori massimi fusibile:

250VAC @ cosØ= 1

valori fusibile 5A

30VCC @ cosØ= 1

valori fusibile 5A

Tutti i conduttori che portano tensioni pericolose devono essere dotati di meccanismi di commutazione o scollegamento esterni che garantiscano almeno 3 mm di separazione a livello di tutti i poli.

L'installazione o l'utilizzo dell'unità in contravvenzione con i requisiti che precedono può compromettere la sicurezza elettrica dell'unità.



Manutenzione

Assicurarsi che tutte le fonti di alimentazione dell'unità siano adeguatamente isolate prima di procedere alla manutenzione, ispezione o pulizia.

All'interno dell'unità non sono presenti componenti manutenibili dall'utente. Evitare nel modo più assoluto di aprire la custodia dello strumento.

Controllare regolarmente tutti i collegamenti esterni. Sostituire eventuali cavi danneggiati e riserrare qualsiasi collegamento allentato.

Utilizzare un panno asciutto per pulire la custodia dell'unità.



Programmazione

Avvertenza: Se nel DPM sono state installate la scheda di uscita relè e/o quella di uscita analogica opzionali, impostando il sistema in modalità Programmazione entrambi i relè verranno disattivati e l'uscita analogica verrà impostata sul valore minimo (0V o 4mA), indipendentemente dal valore del segnale di entrata.



Diagnostica

Avvertenza: L'esecuzione dei test diagnostici causa l'attivazione dell'uscita analogica e dei relè, nel caso in cui tali schede opzionali siano state installate. Innanzitutto, scollegare l'alimentazione dal DPM e le uscite da eventuali carichi che non devono essere attivati. Se la scheda di comunicazione RS485 opzionale è stata installata, il DPM risponde al comando QST con il valore di entrata adattato.

Mounting, Montage, Montaje, Montaggio

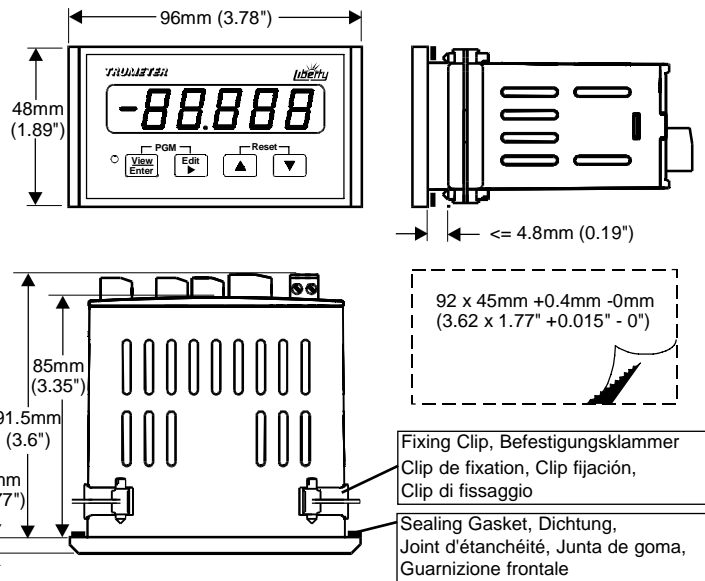

DO NOT OVERTIGHTEN screws, or the gasket will be squeezed out from behind the bezel.

Die Schrauben NICHT ZU FEST ANZIEHEN, anderenfalls wird Dichtung aus dem Deckring gedrückt.

NE PAS TROP SERRER les vis, sans quoi la garniture sera chassée hors du logement.
NO APRETAR EN EXCESO los tornillos, o el obturador saltará afuera por detrás del bisel.

NON STRINGERE ECCESSIVAMENTE le viti altrimenti la guarnizione verrà spinta fuori dal frontale.

Connections, Anschlüsse, Raccordements, Conexiones, Collegamenti

Power Supply, Versorgung, Alimentation, Alimentación, Alimentazione

8780-X: DC (CC)

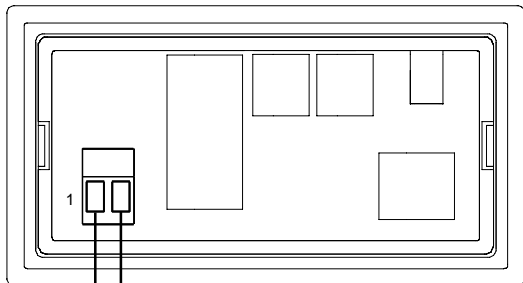

0.2A, 250V

Anti-surge
Verzögerungszeit
À action temporisée
Temporizado
Ritardato

see page 2
siehe Seite 3
voir page 4
ver página 6
vedi pagina 7

Power Supply, Versorgung, Alimentation, Alimentación, Alimentazione

8781-X: AC (CA)

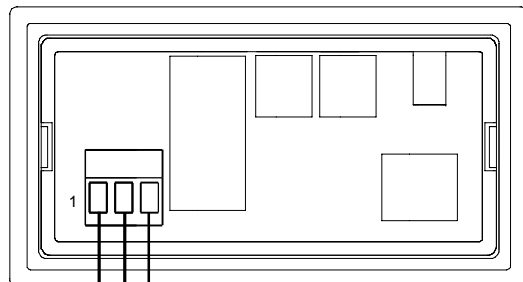

0.2A, 250V

Anti-surge
Verzögerungszeit
À action temporisée
Temporizado
Ritardato

see page 2
siehe Seite 3
voir page 4
ver página 6
vedi pagina 7

Count Inputs, Zähl Eingänge, Entrées Comptage, Entradas de conteo, Ingressi conteggio

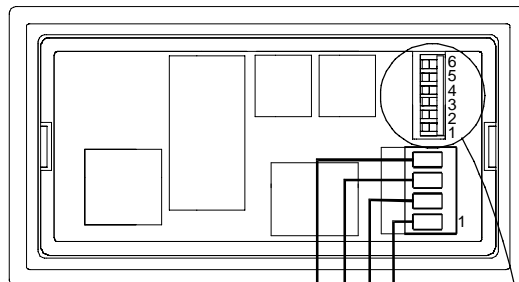

Output, Ausgang, Sortie, Salida, Uscita

+12V ±12% @ 75mA

A

B

0V, Common, Masse,

Commun, Común, Comune

see page 18
siehe Seite 18
voir page 18
ver página 18
vedi pagina 18

Control Inputs, Kontrolleingänge, Entrées de Contrôle, Entradas de Control, Ingressi Controllo

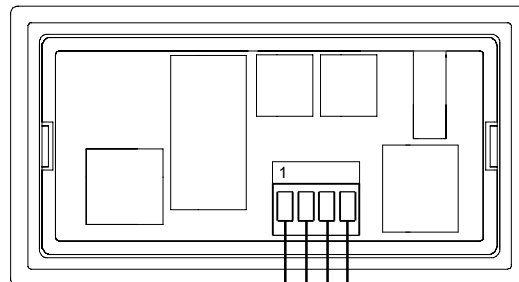

1

2

3

0V, Common, Masse,

Commun, Común, Comune

see pages 19
siehe Seiten 19
voir pages 19
ver páginas 19
vedi pagini 19

**Option Board, Optionskarte, Cartes en option,
Cuadro opcional, Scheda opzionale 878X-1, 878X-3, 878X-5, 878X-7:**

Relay, Relais, Relé, Relè

see page 25, siehe Seite 25, voir page 25, ver página 25, vedi pagina 25

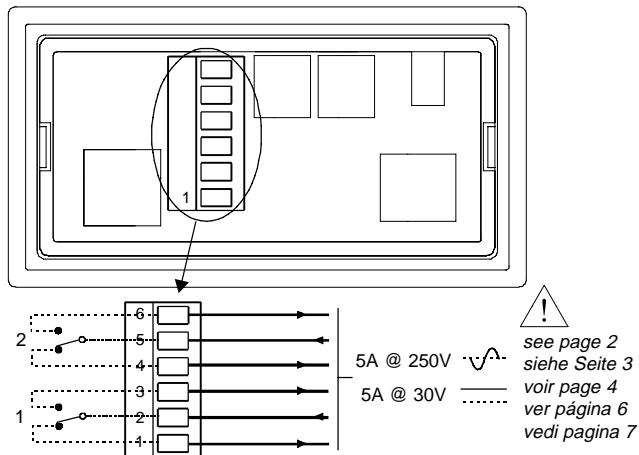

Relays shown in released (not operated) state.

Die Relais werden im freigegebenen Zustand (nicht in Betrieb) wiedergegeben.

Relais au repos (non commandé)

Relés en posición de reposo (desexcitados).

Relè diseccitato (non azionati).

Note: An RC surge suppressor is recommended across inductive loads.

Hinweis: Es wird empfohlen, zwischen induktiven Lasten einen RC-Stromstoßstabilisator einzusetzen.

Remarque: une protection RC de surtension est recommandée pour les charges inductives.

Nota: Se recomienda un compresor de sobrevoltaje RC por encima de las cargas inductivas.

Nota: Si consiglia un soppressore RC di sovracorrenti transitorie verso i carichi induttivi.

**Option Board, Optionskarte, Cartes en option,
Cuadro opcional, Scheda opzionale**

878X-2, 878X-3, 8788-6, 878X-7:

Analog Output, Analogausgang, sortie analogique,

Salida analógica, Uscita Analogica

see page 26, siehe Seite 26, voir page 26, ver página 26, vedi pagina 26

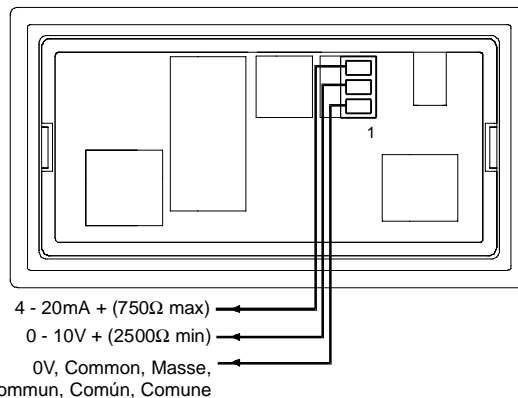

**Option Board, Optionskarte, Cartes en option,
Cuadro opcional, Scheda opzionale 878X-4, 878X-5, 878X-5, 878X-7:**

RS485 see page 26, siehe Seite 26, voir page 26, ver página 26, vedi pagina 26

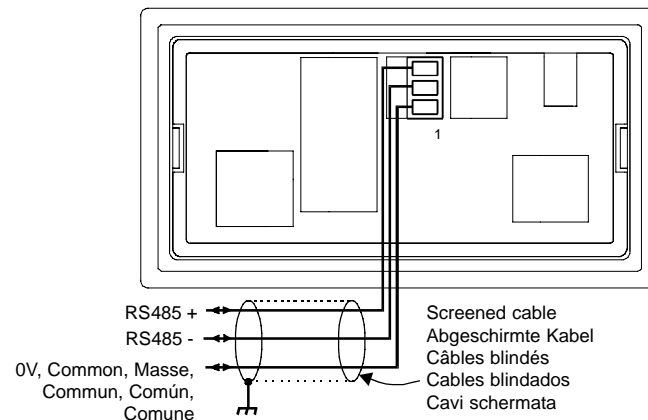

Specification

AC Power Supply (8781-X)

Input Power
94-240 VAC ±10%, 20 VA
47-63 Hz

External Fuse
0.2A, 250 VAC, Time Delay
(T200mA, 250V)

Isolation
2300 VAC

DC Power Supply (8780-X)

Input Power
9-30 VDC, 12 VA
Reverse voltage protection

External Fuse
2.0A, 50 VDC, Time Delay
(T2A, 50V)

Isolation
2300 VAC to signal inputs and
relays, 500 VAC to RS485
and analog outputs

DC Power Output

12V DC ± 12% 75mA max
Short circuit protection

Relay option board (878X-1, 878X-3, 878X-5, 878X-7)

Relays
2 SPCO

Contacts
5A, 250V AC or 30V DC

Isolation
2300V AC

Analog Output option board (878X-2, 878X-3, 878X-6, 878X-7)

Outputs
4-20mA DC (<750Ω load),
0-10V DC (>2500Ω load)

Accuracy
± 0.13% full scale
100ppm/°C
+ 0.07% full scale change
over 4-20mA load range

Isolation
2300V AC to signal inputs,
relays and AC power supply,
500V AC to RS485 and DC
power supply

Spezifikation

Versorgung AC (8781-X)

Eingang Netzstrom
94-240 VAC ±10%, 20 VA
47-63 Hz

Externe Sicherung
0,2A 250 VAC,
Verzögerungszeit
(T200mA, 250V)

Isolierung
2300 VAC

Versorgung DC (8780-X)

Eingang Netzstrom
9-30 VDC, 12 VA
Rückspannungsschutz

Externe Sicherung
2,0A 50 VDC,
Verzögerungszeit (T2A, 50V)

Isolierung
2300 VAC an Signaleingänge
und Relais, 500 VAC an RS
485 und Analogausgänge

Ausgang DC

12V DC ± 12% 75mA max
Kurzschlusschutz

Relaisoptionskarte

(878X-1, 878X-3, 878X-5, 878X-7)

Relais
2 SPCO

Kontakt
5A, 250V AC oder 30V DC

Isolierung
2300V AC

Analogausgänge- optionskarte (878X-2, 878X-3, 878X-6, 878X-7)

Ausgänge
4-20mA DC (<750Ω zwische),
0-10V DC (>2500Ω zwische)

Toleranz
± 0,13% Skalenendwert
100ppm/°C
+ 0,07%
Skalenendwertänderung über
4-20mA Lastbereich

Isolierung

2300V AC an Signaleingänge
und Relais und Versorgung
AC, 500V AC an RS485 und
Versorgung DC

Caractéristiques

Alimentation CA (8781-X)

Alimentation en entrée
94-240 VCA, ±10%, 20 VA
47-63 Hz

Fusible externe
0.2A, 250 VCA, à action
temporisée (T200mA, 250V)

Isolation
2300 VCA

Alimentation CC (8780-X)

Alimentation en entrée
9-30 VCC, 12 VA
Protection inversion de polarité

Fusible externe
2.0A, 50 VCC, à action
temporisée (T2A, 50V)

Isolation
2300 VCA aux entrées de signal
et relais, 500 VCA au RS485 et
aux sorties analogiques

Alimentation auxiliaire

12V DC ± 12% 75mA max
Protection court-circuit

Carte relais en option

(878X-1, 878X-3, 878X-5, 878X-7)

Relais
2 SPCO, 2 contacts RCT

Contacts
5A, 250V CA ou 30V CC

Isolation
2300V CA

Carte sortie analogique en option

(878X-2, 878X-3, 878X-6, 878X-7)

Sortie
4-20mA CC (<750Ω charge),
0-10V CC (>2500Ω charge)

Précision
± 0.13% pleine échelle
100ppm/°C
+ 0.07% pleine échelle sur
plage du 4-20mA

Isolation

2300V CA aux entrées de
signal, relais et alimentation CA,
500V CA au RS485 et
alimentation CC

Especificaciones

Alimentación CA (8781-X)

Potencia de entrada
94-240 VCA, ±10%, 20 VA
47-63 Hz

Fusible exterior
0.2A, 250 VCA, Temporizado
(T200mA, 250V)

Aislamiento
2300 VCA

Alimentación CC (8780-X)

Potencia de entrada
9-30 VCC, 12 VA
Protección voltaje inversa

Fusible exterior
2.0A, 50 VCC, Temporizado
(T2A, 50V)

Aislamiento
2300 VCA para señalar
entradas y relés, 500 VCA para
RS485 y salidas analógicas

Salida de potencia CC

12V CC ± 12% 75mA max
Protección cortocircuito

Cuadro opcional relé

(878X-1, 878X-3, 878X-5, 878X-7)

Relés
2 SPCO

Contacts
5A, 250V CA o 30V CC

Aislamiento
2300V CA

Cuadro opcional salida analógica (878X-2, 878X-3, 878X-6, 878X-7)

Salidas
4-20mA CC (<750Ω carga),
0-10V CC (>2500Ω carga)

Precisión
± 0.13% escala industrial
100ppm/°C
+ 0.07% conmutador escala
industrial 4 - 20mA extensión
carga

Aislamiento

2300V CA para señalar
entradas, relés y alimentación
CA, 500V CA para RS485 y
alimentación CC

Specifiche

Alimentazione (8781-X)

Potenza di entrata
94-240 VCA, ±10%, 20 VA
47-63 Hz

Fusibile Esterno
0.2A, 250 VCA, Ritardato
(T200mA, 250V)

Isolamento
2300 VCA

Alimentazione CC (8780-X)

Potenza di entrata
9-30 VCC, 12 VA
Protezione di tensione inversa

Fusibile Esterno
2.0A, 50 VCC, Ritardato
(T2A, 50V)

Isolamento
2300 VCA alle ingressi di
segnale e ai relé, 500 VCA a
RS485 e alle uscite analogiche

Uscita di Potenza

12V CC ± 12% 75mA max
Protezione di cortocircuito

Scheda opzionale relé

(878X-1, 878X-3, 878X-5, 878X-7)

Relé
2 SPCO

Contacti
5A, 250V CA o 30V CC

Isolamento
2300V CA

Scheda opzionale Uscita

Analoga (878X-2, 878X-3, 878X-6, 878X-7)

Uscite
4-20mA CC (<750Ω carico),
0-10V CC (>2500Ω carico)

Accuratezza
± 0.13% su fondo scala
100ppm/°C
+ 0.07% di risoluzione su
4-20mA di campo

Isolamento

2300V CA ingressi di segnale,
relé e alimentazione AC,
500V CA RS485 e
alimentazione CC

**RS485 option board
(878X-4, 878X-5, 878X-6,
878X-7)**

Protocol

Opto 22® compatible

Isolation

2300V AC to signal inputs,
relays and AC power supply,
500V AC to analog outputs
and DC power supply

Display (all models)

+6, -5% digit red LED
14mm high characters

Memory (all models)

EEPROM, 100 years

**Environmental (all
models)**

Operating Environment

Indoor use to 2000m

Operating Temperature

0°C to +50°C

Storage Temperature

-20°C to +70°C

Relative Humidity

0 to 85%, non-condensing

Sealing

Front panel sealed to IP65
when used with clip mount
and gasket provided.

Installation Category (IEC 664)

Overvoltage category II
Pollution degree 2

Vibration

2.5 g's, 30 to 200 Hz

Shock

2.5 g's, 11 msec half sinewave

EMC

Heavy Industrial:
Immunity to EN 50082-2
Emissions to EN 50081-2

**RS485 Optionskarte
(878X-4, 878X-5, 878X-6,
878X-7)**

Protokoll

Opto 22® kompatibel

Isolierung

2300V AC an Signaleingänge
und Relais und Versorgung AC,
500V AC an Analogausgänge
und Versorgung DC

Display (alle Modelle)

LED +6, -5% stellig, rote
Zeichenhöhe 14mm

Speicher (alle Modelle)

EEPROM, 100 Jahre

Umgebung (alle Modelle)

Operating Environment

Einsatz in Innenbereich, bis
2.000 m

Betriebstemperatur

0°C bis +50°C

Lagertemperatur

-20°C bis +70°C

Relative Luftfeuchtigkeit

0 to 85%, nicht
kondensierend

Dichtung

Frontblende bei Verwendung
von mitgelieferter
Befestigungsklammer und
Dichtung nach IP65
abgedichtet.

Installationskategorie

(IEC 664)

Schutzklasse II
Entstörgrad 2 (IEC64)

Vibrationen

2.5 g's, 30 bis 200 Hz

Stösse

30 g's, 11 ms halbe
Sinuswelle

EMC

Schwerindustrie
Immunität gemäss EN 50082-2
Emissionen gemäss EN
50081-2

**Carte RS485 en option
(878X-4, 878X-5, 878X-6,
878X-7)**

Protocole

Compatible Opto 22®

Isolation

2300V CA aux entrées de
signal, relais et alimentation CA
500V CA aux sorties
analogiques et alimentation CC

**Affichage (tous les
modèles)**

+6, -5% DEL chiffres rouges
caractères 14mm

**Mémoire (tous les
modèles)**

EEPROM, 100 ans

**Environnement (tous les
modèles)**

**Environnement de
fonctionnement**

Utilisation en intérieur jusqu'à
2000m

**Température de
fonctionnement**

de 0°C à +50°C

Température de stockage

de -20°C à +70°C

Humidité relative

0 to 85%, sans condensation

Etanchéité

IP65 en face avant avec
montage par clip et le joint
d'étanchéité fourni

**Catégorie d'installation
(IEC 664)**

Catégorie surtension II
niveau de pollution 2

Vibration

2.5 g's, 30 à 200 Hz

Chocs

30 g's, 11 ms demi onde
sinusoïdale

EMC

Industrie lourde:
Immunité à EN 50082-2
Emissions à EN 50081-2

**Cuadro opcional RS485
(878X-4, 878X-5, 878X-6,
878X-7)**

Protocolo

compatible Opto 22®

Aislamiento

2300V CA para señalar
entradas, relés y alimentación
CA, 500V CA para salidas
analógicas y alimentación CC

**Pantalla (todos los
modelos)**

LED rojo +6, -5% dígitos
caracteres de 14 mm de altura

**Memoria (todos los
modelos)**

EEPROM, 100 años

**Factor ambiental (todos
los modelos)**

**Medio ambiente de
funcionamiento**

En el interior utilizar a 2000m

Temperatura de operación

0°C a +50°C

Temperatura de almacenaje

-20°C a +70°C

Humedad Relativa

0 to 85%, No condensación

Grado de protección

Panel frontal sellado según
IP65 cuando se monta a
presión con el accesorio de
fijación y la junta de goma,
ambos proveídos.

**Categoría de Instalación
(IEC 664)**

Categoría II de sobrevoltaje
grado de contaminación 2

Vibración

2.5 g's, 30 a 200 Hz

Shock

30 g's, media onda senoidal
11 ms

EMC

Industrial pesada:
Inmunidad en EN 50082-2
Emisiones en EN 50081-2

**Scheda opzionale RS485
(878X-4, 878X-5, 878X-6,
878X-7)**

Protocollo

Opto 22® compatibile

Isolamento

2300V CA alle entrate di
segnale, ai relè e alle
alimentazione AC, 500V CA
alle uscite analogiche e
all'alimentazione CC

Display (tutti i modelli)

+6, -5% cifre con LED rosso
caratteri da 14mm

Memoria (tutti i modelli)

EEPROM, 100 anni

Ambientale (tutti i modelli)

Ambiente Operativo

Per uso inferiore a 2000m slm

Temperatura di funzionamento

da 0 a +50°C

**Temperatura di
immagazzinamento**

da -20 a +70°C

Umidità Relativa

da 0 a 85%, senza condensa

Tenuta

Pannello frontale con tenuta
IP65 con fissaggio e
guarnizione in dotazione.

**Categoria di installazione
(IEC 664)**

Categoria di sovratensione II
Grado di inquinamento 2

Vibrazione

2,5 g, da 30 a 200 Hz

Urto

30 g, 11 ms metà sinusoide

CEM

Industriale Pesante:
Immunità in base a
EN 50082-2
Emissioni in base a
EN 50081-2

Count Inputs, Zähleingänge, Entrées Comptage, Entradas de conteo, Ingressi conteggio

see pages 11, 24 siehe Seiten 11, 24 voir pages 11, 24
ver páginas 11, 24 vedi pagini 11, 24

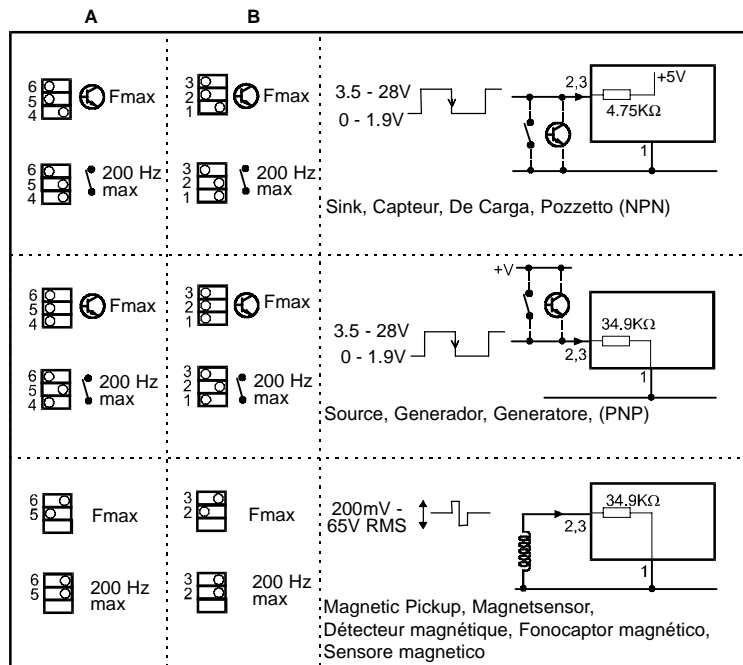

Fmax

| Count mode, Zählermoden, Mode Compteur, Modo de conteo, Modalità di Conteggio | A or B, A oder B A ou B, A o B A o B | A and B, A und B A et B, A y B A e B |
|---|--|--|
| (A+ B-), (A+ B+), (A+ Binh) | 8250 / 8250 Hz | 3000 / 3000 Hz |
| Quad x1, Quad x2 | | 3250 Hz |
| Quad x4 | | 2000 Hz |

Control Inputs, Kontrolleingänge, Entrées de Contrôle, Entradas de Control, Ingressi Controllo

see pages 11, 24 siehe Seiten 11, 24 voir pages 11, 24
ver páginas 11, 24 vedi pagini 11, 24

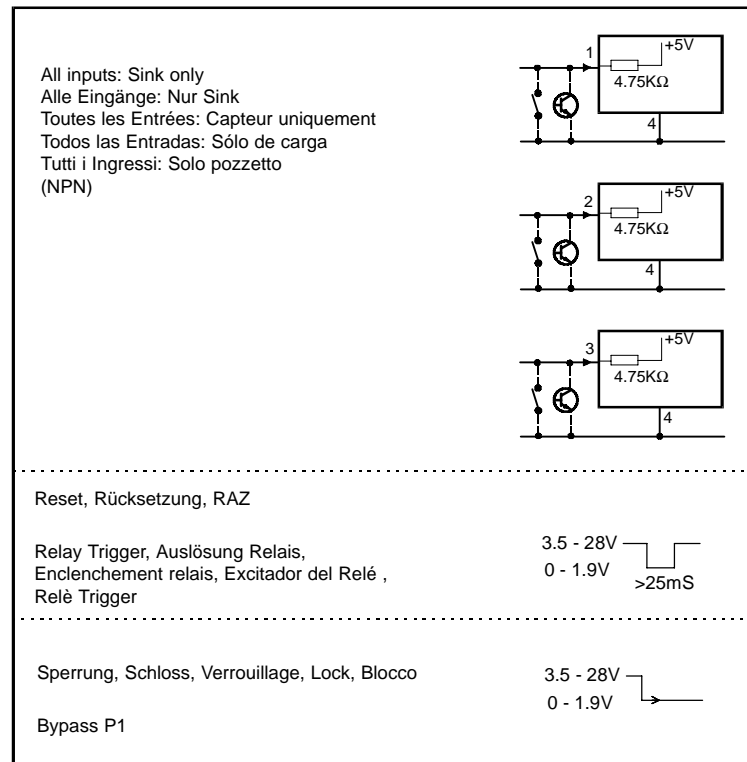

Operation

Base unit

When the power is switched on, the unit is in **Run mode**. In Run mode the contents of the **Registers** can be displayed, edited and reset. These include the Counters, Presets, Rate and PPI (see page 22).

For more details about the counters and presets, see the next page. For more information about scaling, see page 22. For more details about how to operate the unit in Run mode, see page 32.

If **Program Lock** is off, the unit can be put into **Program mode**, and the **Scalars, Count modes, settings for the Option boards, and functions of the Control inputs**, can be programmed by setting the values of the **Function codes** (FC).

For more information about Lock Program, and the Control inputs, see page 24. For more information about how to use Program mode to set the Function codes, see page 36.

When the power is switched off, the contents of all the Registers and Function codes are stored in memory, until the power is switched on again.

If the Totaliser counts up to 999,999 the next count will rollover to zero. If the Totaliser counts down to zero, the next count will rollunder to either 999,999 or -1, depending on the setting of **Rollunder** (FC11). If the Totaliser counts down to -99,999 it will stop.

The counters can be reset manually by one or more of the Control inputs, or by the front panel buttons. This depends on the setting of **Control input** (FC20) and **Keypad reset** (FC23). The Total will always reset to zero.

For more information about how the Control counter can be reset, see the next page.

The base unit can be fitted with one or more optional circuit boards. If the Relay option board is **not** installed, then only the Totaliser functions will be available. If the Relay option board **is** installed, then the Count Control functions will also be available.

For more information about the Option boards, see pages 25 and 26.

Totaliser functions

If the Relay option board is not installed:

The unit can be set to display either the **Total**, or the **Rate**, by changing the **Display** setting in Run mode.

The Totaliser is a +6/-5½ digit counter that can count up or down or in both directions, depending on the setting of **Count Mode** (FC7, see page 24).

The 5 digit Rate display is updated each time an input pulse is received, up to a maximum of one update per second. If no pulses are received after nine seconds, the

Rate display will read zero. When the unit is in Quadrature mode, and the Totaliser is counting downwards, the Rate display will have a minus sign. The Rate display can be enabled or disabled by setting **Rate Display** (FC14).

Both the Total and the Rate can be programmed to read in any units by setting the **Scaling parameters** (FC0-6), as described on page 22. The Total display can be further divided by 1, 10 or 100, depending on the setting of **Total Display** (FC16).

Count Control functions

If the Relay option board is installed:

The unit can be set to display any of the Registers (if enabled), by changing the **Display** setting in Run mode.

The Totaliser continues to count the total number of input pulses, or it can be hidden by setting the **Total Display** (FC16) to 0. In addition to the Totaliser, the unit has two more counters - the **Control counter** and the **Batch counter**.

The Control counter is a +6/-5½ digit counter that operates in a similar way to the Totaliser. It has two 6 digit Presets, **P1** and **P2**, that can only be set to positive numbers. The Control counter can be programmed to reset automatically when the count reaches either or both of the two presets, P1 and P2. This depends on the setting of **Reset mode** (FC9) and **Auto-reset** (FC10).

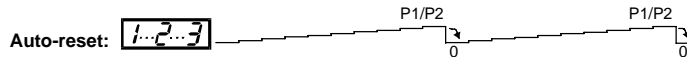

Note that if **Reset mode** (FC9) is set to **Reset to P2**, the counter will count backwards and will Reset and Auto-reset to P2, instead of to zero.

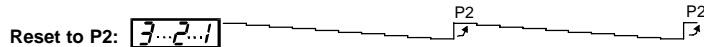

The Batch counter is a 6 digit counter that can only count upwards. If one of the **Auto-reset** (FC10) modes has been set, the Batch counter will count the number of times Auto-reset has occurred. The Batch counter and its preset, **Pb**, can be enabled or disabled by setting **Batch counter** (FC8).

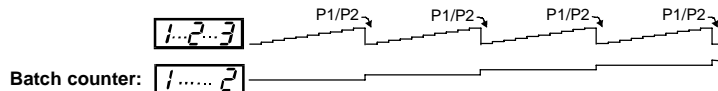

For information about how the relays can be controlled by P1, P2 and Pb, see page 25.

Scaling

The display can be programmed to read in any units by setting the Scaling parameters (Function codes FC0 - FC6).

NOS = Number Of Seconds in time unit (1=seconds, 60=minutes, 3600=hours etc)

PPI = Pulses Per Item (revolution, metre, litre, machine cycle etc)

DPF = Decimal Point Factor (from table below)

| Count Decimal Point | CDPF | Rate Decimal Point | RDPF |
|---------------------|-------|--------------------|-------|
| 100000 | 1 | 10000 | 1 |
| 10000.0 | 10 | 1000.0 | 10 |
| 1000.00 | 100 | 100.00 | 100 |
| 100.000 | 1000 | 10.000 | 1000 |
| 10.0000 | 10000 | 1.0000 | 10000 |

If **Scaling mode (FC0)** is set to **Calculated (0)**:

PPI and NOS must be entered into FC1 and FC6.

Count Decimal Point and Rate Decimal Point must be entered into FC3 and FC5.

The unit will calculate Count Scaler and Rate Scaler (FC2 and FC4).

If **Scaling mode (FC0)** is set to **Calculated (1)**:

PPI may also be edited in Run mode.

If **Scaling mode (FC0)** is set to **Programmed (2)**:

Count Decimal Point and Rate Decimal Point must be entered into FC3 and FC5.

Count Scaler and Rate Scaler must be calculated as shown below, and entered into FC2 and FC4.

$$\text{Count Scaler} = \frac{\text{CDPF}}{\text{PPI}}$$

$$\text{Rate Scaler} = \frac{\text{NOS} \times \text{RDPF}}{\text{PPI}}$$

Examples:

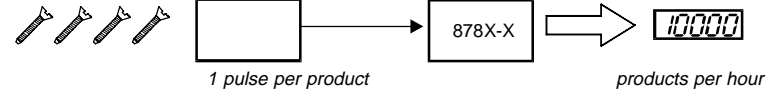

Display
Rate Decimal Point
Rate Scaler

Rate
10000
 $\frac{\text{NOS} \times \text{RDPF}}{\text{PPI}} = \frac{3600 \times 1}{1} = 3600$

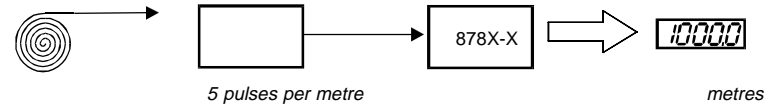

Display
Count Decimal Point
Count Scaler

Count
1000.0
 $\frac{\text{CDPF}}{\text{PPI}} = \frac{10}{5} = 2$

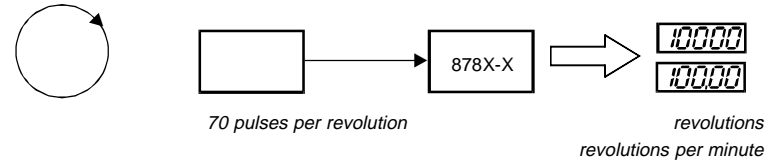

Display
Count Decimal Point
Count Scaler

Count
10000
 $\frac{\text{CDPF}}{\text{PPI}} = \frac{1}{70} = 0.0143$

Display
Rate Decimal Point
Rate Scaler

Rate
100.00
 $\frac{\text{NOS} \times \text{RDPF}}{\text{PPI}} = \frac{60 \times 100}{70} = 85.71$

Count inputs

The unit has two count inputs, A and B (see pages 11 and 18). The counter can be programmed to operate in any of the six modes shown below, by setting Count mode (FC7).

Count modes

A+ B-

A counts up, B counts down

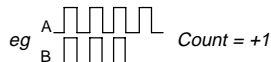

A+ B+

A counts up, B counts up

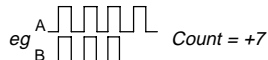

A+ Binh

A counts up, B inhibits counter



Quadrature x 1

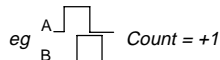

Quadrature x 2

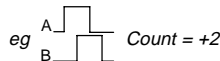

Quadrature x 4

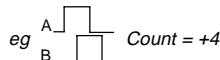

Note that if Reset mode (FC9) is set to *Reset to P2*, the counter will count backwards in all modes.

Control inputs

The unit has three control inputs (see pages 11 and 19) that can be used to reset the counters or to prevent users from accessing some functions. These are dependant on the Control Input setting (FC20).

We recommend that one of the Control inputs should be set to *Lock Program*, to prevent unauthorised changes to the unit's programming.

Relay option board

This contains two SPCO relays (see page 12).

Each relay can be programmed to operate in one of the modes shown below, by setting its Relay mode (FC30 or FC40).

Relay modes

Latched normal

Relay operates when triggered (FC32 or FC42).

Relay releases when triggered (FC32 or FC42).

Latched reverse

as above, but operate and release are swapped.

Pulsed normal

Relay operates when triggered.

Relay releases after the time programmed into Relay Pulse time (FC31 or FC 41), unless a release trigger occurs before the end of the time.

Pulsed reverse

as above, but operate and release are swapped.

Preset low

Relay operates when Control counter \leq Preset.

Relay releases when Control counter $>$ Preset.

Preset high

Relay releases when Control counter $<$ Preset.

Relay operates when Control counter \Rightarrow Preset.

In all modes, when the power is switched off:

Both relays are released.

Latched and pulsed modes:

The relay can be triggered:

by the Control counter reaching P1, P2 or Pb,

or by the Relay Control input,

or Reset and Auto-reset,

depending on the setting of Relay Trigger (FC32 or FC42).

When the power is switched on:

The relays will not operate until re-triggered.

Preset low and Preset high modes:

The relay can be controlled by P1 or P2, depending on the setting of Relay Preset (FC34 or FC44).

When the power is switched on, the value of the Control counter is maintained from the previous session, but:

If Relay Preset test (FC35 or FC45) is *Disabled*, the relay will not operate until an input pulse causes the Control counter to reach the Preset.

If Relay Preset test (FC35 or FC45) is *Enabled*, the relay will immediately operate if the value of the Control counter had reached the Preset in the previous session.

Analog Output option board

This provides two analog outputs (4-20mA and 0-10V) (see page 13).

The outputs can be programmed to follow the Rate, the Totaliser counter, the Control counter or the Batch counter (if enabled), by setting Analog Assignment (FC70)

The output can be programmed to any range, by setting the Analog Output Offset (FC71) and Analog Output Full Scale (FC72).

When the display reading is equal to the Analog Output Offset value, the outputs will be 4mA and 0V.

When the display reading is equal to the Analog Output Full Scale value, the outputs will be 20mA and 10V.

When the display reading is in between these two values, the outputs will be:

$$V = \frac{(\text{Display Reading} - \text{Output Offset})}{(\text{Output Full Scale} - \text{Output Offset})} \times 10 \quad V$$

$$I = \left(\frac{(\text{Display Reading} - \text{Output Offset})}{(\text{Output Full Scale} - \text{Output Offset})} \times 16 \right) + 4 \text{ mA}$$

RS485 option board

This provides a two-way serial communication link with a remote computer (see page 13).

The serial link can be programmed by setting RS485 Serial Address (FC60), RS485 Baud Rate (FC61) and RS485 Parity (FC62).

For further information about the serial communication protocol, contact your local Trumeter office.

Examples

Simple Totaliser with Inhibit and Reset Inputs and Keypad Reset

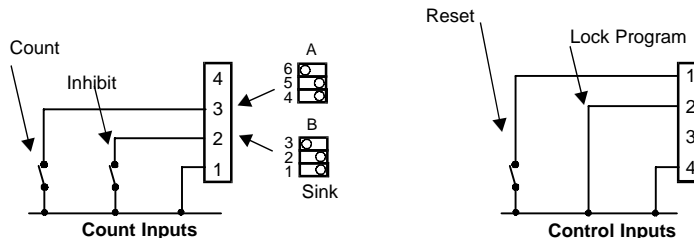

Function Codes

| | | | |
|------|---------------------|---------|---|
| FC0 | Scaling mode | 0 | Calculated |
| FC1 | PPI | 1.00 | |
| FC2 | Count Scaler | 1.00000 | |
| FC3 | Count Decimal Point | 0 | 100000 |
| FC7 | Count Mode | 2 | A+ BinH |
| FC14 | Rate Display | 0 | Disabled |
| FC16 | Total Display | 1 | Total displayed |
| FC20 | Control Inputs | 130 | Input 1: Reset Total Input 2: Lock Program |
| FC23 | Keypad reset | 1 | Reset Total |

Machine Controller with Manual Start, Manual Stop and Automatic Stop

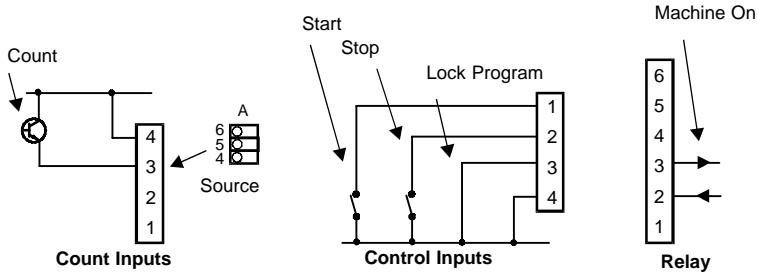

Registers

P1 Preset 1 Autostop Value

Function Codes

| | | |
|-------|-----------------|---|
| FC0-6 | Scaling | see page 22 |
| FC7 | Count Mode | 0,1,2 A+ |
| FC8 | Batch Counter | 0 Disabled |
| FC9 | Reset Mode | 0 Normal |
| FC10 | Auto Reset | 0 Disabled |
| FC20 | Control Inputs | 583 Input 1: Reset Control Counter Input 2: Relay Control Input 3: Lock Program |
| FC30 | Relay 1 Mode | 1 Latched Normal |
| FC32 | Relay 1 Trigger | 20021 Reset operates relay P1 releases relay Relay Control releases relay |

Repeating Two Speed Controller with Keypad Start, Keypad Reset and Timed Finishing Process.

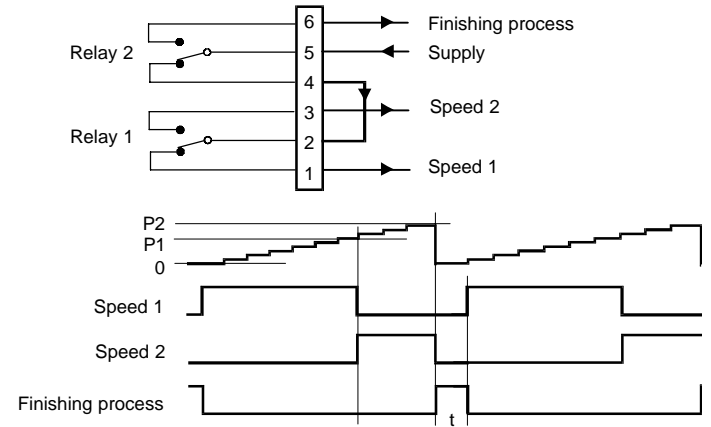

Registers

P1 Preset 1 Speed 2 Start Value
P2 Preset 2 Finishing Process Start Value

Function Codes

| | | |
|-------|--------------------|--|
| FC0-6 | Scaling | see page 22 |
| FC7 | Count Mode | to suit input device |
| FC8 | Batch Counter | 0 Disabled |
| FC9 | Reset Mode | 0 Normal |
| FC10 | Auto Reset | 2 P2→0 |
| FC20 | Control Inputs | 300 Input 1: Lock Program |
| FC23 | Keypad Reset | 5 Resets all Counters |
| FC30 | Relay 1 Mode | 1 Latched Normal |
| FC32 | Relay 1 Trigger | 12002 P1 operates relay P2 releases relay Reset releases relay |
| FC40 | Relay 2 Mode | 3 Pulsed Mode |
| FC41 | Relay 2 Pulse Time | t Finishing Process duration |
| FC42 | Relay 2 Trigger | 01002 P2 operates relay Reset releases relay |

Batch Controller with Keypad Start, Keypad Reset, Automatic Stop after P_b Batches, and Remaining Quantity Display.

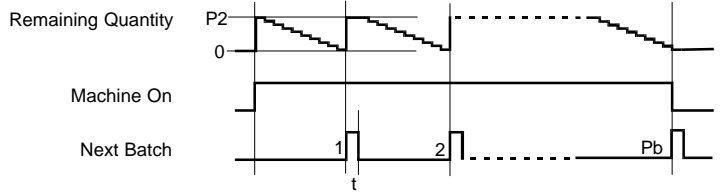
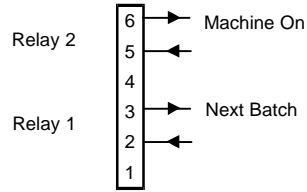

Registers

| | | |
|----|--------------|-------------------|
| P2 | Preset 2 | Batch Quantity |
| Pb | Batch Preset | Number of Batches |

Function Codes

| | | |
|-------|--------------------|---|
| FC0-6 | Scaling | see page 22 |
| FC7 | Count Mode | to suit input device |
| FC8 | Batch Counter | 2 Enabled, with Batch Preset |
| FC9 | Reset Mode | 1 Reset to P2 |
| FC10 | Auto Reset | 2 P2→0 (0→P2) |
| FC20 | Control Inputs | 300 Input 1: Lock Program |
| FC23 | Keypad Reset | 5 Resets all Counters |
| FC30 | Relay 1 Mode | 3 Pulsed Normal |
| FC31 | Relay 1 Pulse Time | t Next Batch pulse duration |
| FC32 | Relay 1 Trigger | 01000 P2 operates relay |
| FC40 | Relay 2 Mode | 1 Latched Normal |
| FC42 | Relay 2 Trigger | 00012 Reset operates relay Pb releases relay |

Position Display with High and Low Level Warning Outputs.

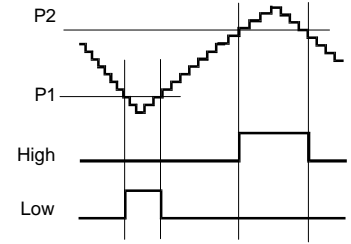
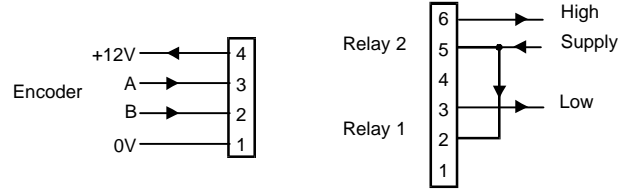

Note: The zero position must be set when the power is switched on.

Registers



| | | |
|----|----------|------------|
| P1 | Preset 1 | Low Level |
| P2 | Preset 2 | High Level |



Function Codes

| | | |
|-------|----------------|---------------------------|
| FC0-6 | Scaling | see page 22 |
| FC7 | Count Mode | to suit encoder |
| FC8 | Batch Counter | 0 Disabled |
| FC9 | Reset Mode | 0 Reset to P2 |
| FC10 | Auto Reset | 0 Normal |
| FC20 | Control Inputs | 300 Input 1: Lock Program |
| FC30 | Relay 1 Mode | 5 Preset Low |
| FC34 | Relay 1 Preset | 0 P1 |
| FC40 | Relay 2 Mode | 6 Preset High |
| FC44 | Relay 2 Preset | 1 P2 |

Run Mode

When the power is switched on, the unit is in **Run mode**. In Run mode, the contents of the **Registers** can be displayed, edited and reset. These include the Counters, Presets, Rate and PPI.

Use the ,  and  buttons to select a Register, as shown below. Release the buttons to see the Register value.

Use the ,  and  buttons to edit the value, as shown on the next page.

Press  to see the Register name.

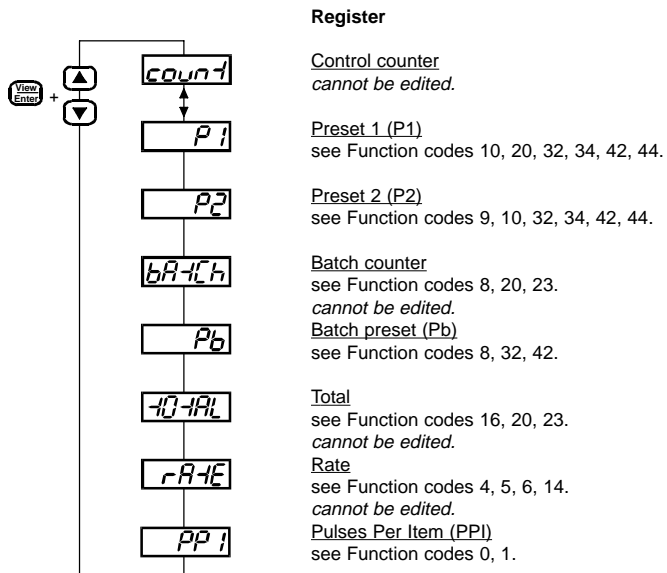

Register

Control counter
cannot be edited.

Preset 1 (P1)
see Function codes 10, 20, 32, 34, 42, 44.

Preset 2 (P2)
see Function codes 9, 10, 32, 34, 42, 44.

Batch counter
see Function codes 8, 20, 23.
cannot be edited.

Batch preset (Pb)
see Function codes 8, 32, 42.

Total
see Function codes 16, 20, 23.
cannot be edited.

Rate
see Function codes 4, 5, 6, 14.
cannot be edited.

Pulses Per Item (PPI)
see Function codes 0, 1.

Note: To set all Counters and Presets to zero, enter Program mode, and set Load Defaults (FC50) to 2.

Editing the Registers

Use the ,  and  buttons to edit the value, as shown below:

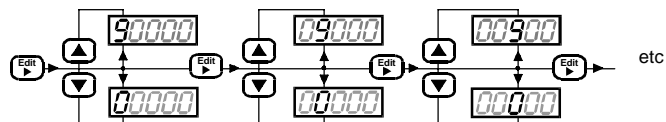

Press  to save the edited value.

To reset the counters, press  and  simultaneously (if enabled by Keypad reset - FC23).

Program Mode

Caution: If the optional relay output and/or analog output board(s) are installed in the DPM, then entering Program mode will cause both relays to release and the analog output to go to its minimum value (0V or 4 mA) regardless of the input signal value.

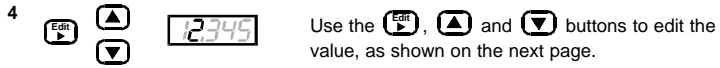
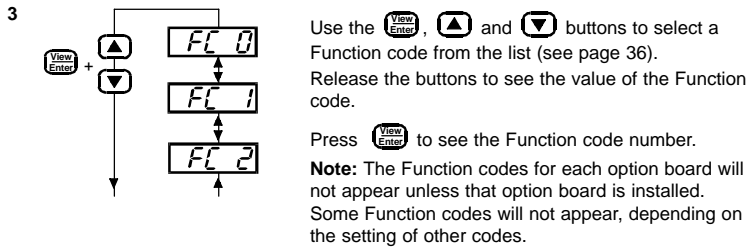
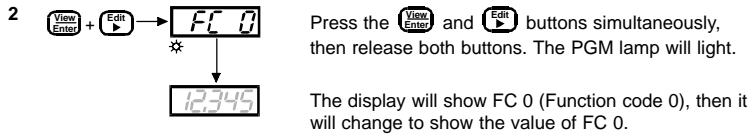
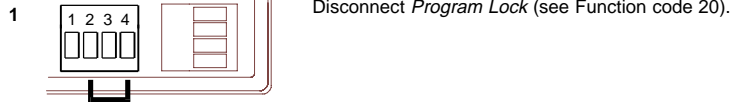

To program the base unit and the option boards, follow the instructions below.

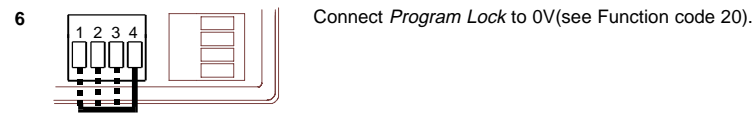
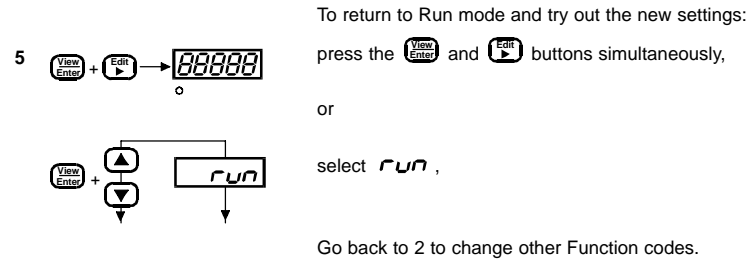

Note: To set all Function Codes to their default values, set Load Defaults (FC50) to 1.



Editing the Function Codes

Use the ,  and  buttons to edit the value, as shown below:

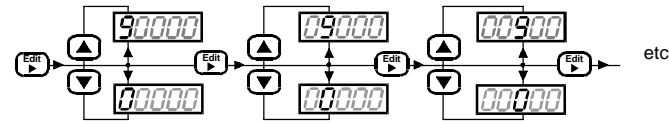

Press  to save the edited value.

The Function Codes

| | (default) values | Function Code | Your Settings |
|---|--------------------------------|--|---------------|
| 0 | (0) 0 | Scaling mode (see page 22) Calculated. <i>PPI entry in Program mode only.</i> | |
| | 1 | Calculated. <i>PPI entry in Program mode or Run mode.</i> | |
| | 2 | Programmed. <i>Count Scaler and Rate Scaler required.</i> | |
| | | | |
| 1 | (1.00) 0.01 - 9999.99* | Pulses Per Item (PPI) (see page 22) <i>*but any value that causes Count Scaler or Rate Scaler to be out of range will be rejected.</i> | |
| 2 | (1.00000) 0.00001 - 9.99999 | Count Scaler (see page 22) | |
| 3 | (0) 0 | Count Decimal Point (see page 22) 100000 | |
| | 1 | 10000.0 | |
| | 2 | 1000.00 | |
| | 3 | 100.000 | |
| | 4 | 10.0000 | |
| 4 | (60.00) 0.001 - 9999 | Rate Scaler (see page 22) | |
| 5 | (0) 0 | Rate Decimal Point (see page 22) 10000 | |
| | 1 | 1000.0 | |
| | 2 | 100.00 | |
| | 3 | 10.000 | |
| | 4 | 1.0000 | |
| 6 | (60) 1 - 99,999 | Number of Seconds in time unit (NOS) (see page 22) 1=seconds, 60=minutes, 3600=hours etc | |
| | | | |

| | (default) values | Function Code | Your Settings |
|----|------------------|--|---------------|
| 7 | (0) 0 | Count Mode (see page 24) A+ B- | |
| | 1 | A+ B+ | |
| | 2 | A+ BinH | |
| | 3 | Quadrature x 1 | |
| | 4 | Quadrature x 2 | |
| | 5 | Quadrature x 4 | |
| 8 | (0) 0 | Batch Counter (see page 21) Disabled | |
| | 1 | Enabled, but no Batch preset | |
| | 2 | Enabled, with Batch preset | |
| 9 | (0) 0 | Reset mode (see page 21) Normal <i>Control counter resets to zero</i> | |
| | 1 | Reset to P2 <i>Control counter counts backwards and resets to P2</i> | |
| 10 | (0) 0 | Auto-reset (see page 21) Disabled | |
| | 1 | P1→0 | |
| | 2 | P2→0 | |
| | 3 | P1/P2→0 | |
| 11 | (0) 0 | Rollunder (see page 20) 999,999 | |
| | 1 | -1 | |
| | | | |

| | (default) values | Function Code | Your Settings |
|----|--|---|---------------|
| 14 | (0) | Rate display (see page 20) | |
| | 0 | Disabled | |
| | 1 | Enabled | |
| 16 | (0) (1*) | Total display (see page 20) | |
| | 0 | Disabled <i>not possible unless Relay option board is installed</i> | |
| | 1 | Total displayed * default if Relay option board is not installed | |
| | 2 | Total ÷ 10 | |
| | 3 | Total ÷ 100 | |
| 20 | (000) abc: | Control inputs (see page 24) a: input 1, b: input 2, c: input 3 eg. 037: | |
| | | input 1 - No action input 2 - Lock Program input 3 - Reset all counters | |
| | 0 | No action | |
| | 1 | Reset Total | |
| | 2 | Lock all | |
| | 3 | Lock Program | |
| | 4 | Lock Program and P1 | |
| | 5 | Reset Control counter | |
| | 6 | Reset Batch counter | |
| | 7 | Reset all counters | |
| 8 | Relay Control input see FC32 and FC42 | | |
| 9 | Bypass P1 | | |
| 23 | (0) | Keypad reset (see page 20) | |
| | 0 | Disabled | |
| | 1 | Reset Total <i>2 - 5: only if Relay option board is installed</i> | |
| | 2 | Reset Control counter | |
| | 3 | Reset Batch counter | |
| | 4 | Reset displayed counter | |
| | 5 | Reset all counters | |

| | (default) values | Function Code | Your Settings |
|----|------------------------|---|---------------|
| 30 | (0) | Relay 1 mode (see page 25) | |
| | 0 | Disabled | |
| | 1 | Latched normal | |
| | 2 | Latched reverse | |
| | 3 | Pulsed normal | |
| | 4 | Pulsed reverse | |
| | 5 | Preset low | |
| | 6 | Preset high | |
| 31 | (1.00) 0.01 - 99.99 | Relay 1 Pulse time (see page 25) Seconds | |
| 32 | (00000) abcde: | Relay 1 Trigger (see page 25 and FC20) a: P1, b: P2, c: Pb, d: Relay Control, e: Reset eg. 12002: P1 operates Relay 1 P2 and Reset release Relay 1 | |
| | 0 | No action | |
| | 1 | Operate | |
| | 2 | Release | |
| 34 | (0) | Relay 1 Preset (see page 25) (FC30 = 5 or 6 only) Relay 1 controlled by P1 | |
| | 0 | Relay 1 controlled by P2 | |
| | 1 | | |
| 35 | (0) | Relay 1 Preset test (see page 25) (FC30 = 5 or 6 only) Disabled | |
| | 0 | Enabled | |
| | 1 | | |

| | (default) values | Function Code | Your Settings |
|----|------------------------|--|---------------|
| 40 | (0) | Relay 2 mode (see page 25) | |
| | 0 | Disabled | |
| | 1 | Latched normal | |
| | 2 | Latched reverse | |
| | 3 | Pulsed normal | |
| | 4 | Pulsed reverse | |
| | 5 | Preset low | |
| 6 | Preset high | | |
| 41 | (1.00) 0.01 - 99.99 | Relay 2 Pulse time (see page 25) Seconds | |
| 42 | (00000) | Relay 2 Trigger (see page 25 and FC20) | |
| | abcde: | a: P1, b: P2, c: Pb, d: Relay Control, e: Reset eg. 12002: P1 operates Relay 2 P2 and Reset release Relay 2 | |
| | 0 | No action | |
| | 1 | Operate | |
| | 2 | Release | |
| 44 | (0) | Relay 2 Preset (see page 25) (FC40 = 5 or 6 only) | |
| | 0 | Relay 1 controlled by P1 | |
| | 1 | Relay 1 controlled by P2 | |
| 45 | (0) | Relay 2 Preset test (see page 25) (FC40 = 5 or 6 only) | |
| | 0 | Disabled | |
| | 1 | Enabled | |
| 50 | (0) | Load Defaults (see pages 27 and 29) | |
| | 0 | No action | |
| | 1 | Load default values into all Function codes | |
| | 2 | Set all Presets and Counters to zero | |

| | (default) values | Function Code | Your Settings |
|----|-------------------|--|---------------|
| 60 | (00) | RS485 Serielle Adresse (see page 26) | |
| | 00 - 99 | | |
| 61 | (4) | RS485 Baud Rate (see page 26) | |
| | 0 | 1200 | |
| | 1 | 2400 | |
| | 2 | 4800 | |
| | 3 | 9600 | |
| 4 | 19200 | | |
| 62 | (0) | RS485 Parity (see page 26) | |
| | 0 | none | |
| | 1 | odd | |
| 2 | even | | |
| 70 | (0) | Analog Assignment (see page 26) | |
| | 0 | Rate | |
| | 1 | Total | |
| | 2 | <i>2 - 3: only if Relay option board is installed</i> Control counter | |
| 3 | Batch counter | | |
| 71 | (000000) | Analog Output Offset (see page 26 and FC11) | |
| | -99,999 - 99,999 | if Rate | |
| | 0 - 999,999 | if Total, and Rollunder = 999,999 if Control counter, and Rollunder = 999,999 if Batch counter | |
| | -99,999 - 999,999 | if Total, and Rollunder = -1 if Control counter, and Rollunder = -1 | |
| 72 | (99999*)(999999) | Analog Output Full Scale (see page 26 and FC11) | |
| | -99,999 - 99,999* | if Rate | |
| | 0 - 999,999 | if Total, and Rollunder = 999,999 if Control counter, and Rollunder = 999,999 if Batch counter | |
| | -99,999 - 999,999 | if Total, and Rollunder = -1 if Control counter, and Rollunder = -1 | |



Diagnostics

Caution: Performing the diagnostic tests will turn on the analog output and operate the relays if those options are installed. First remove power from the DPM and disconnect the outputs from any loads that should not be turned on. If the optional RS485 communication board is installed, the DPM will respond with the scaled input value to the QST command.

Tests performed automatically when power is turned on:

888888

Display test if faulty, return to factory for repair

Err

Memory error } return to factory for repair

CAL

Calibration error }

PrG

Programming error } press any key or cycle power OFF then ON

Errun

Run Data error } then re-program

Keyboard diagnostics:

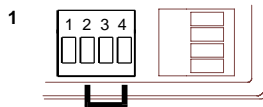

Turn Power OFF
Disconnect *Program Lock* (see Function code 20).

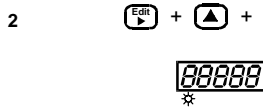

Turn Power ON

Display test All segments and PGM light ON
Relays released
Outputs minimum (0V or 4mA)

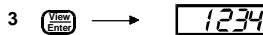

Software part number

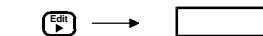

Analog Test Outputs maximum (10V or 20mA)
Display blank

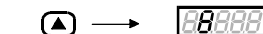

Relay 2 Test Relay 2 operates
Digit Test One digit at a time

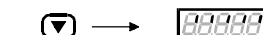

Relay 1 Test Relay 1 operates
Segment Test One segment at a time

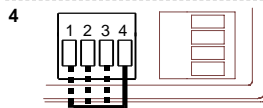

Turn Power OFF
Connect *Program Lock* to 0V(see Function code 20).

Trumeter Company Ltd, Milltown Street, Radcliffe, Manchester
M26 1NX, England
Tel: (44) (0)161 724 6311 Fax: (44) (0)161 724 9455
e-mail: sales.uk@trumeter.com

Trumeter Ireland, PO Box 5050, Drogheda, Ireland
Tel: (353) (0)41 983 7755 Fax: (353) (0)41 983 7753
e-mail:sales.ireland@trumeter.com

Trumeter Company Inc.,1020 North West 6 Street, Suite D,
Deerfield Beach, Florida 33442, U.S.A.
Tel: (1) 954 725 6699 Fax: (1) 954 725 5599
email: sales.usa@trumeter.com

Trumeter Canada, 190 Britannia Road East, Unit 5, Mississauga,
Ontario, L4Z 1W6, Canada
Tel (1) 905 890 0622 Fax: (1) 905 890 7994
email: sales.canada@trumeter.com

Trumeter Deutschland, Postfach 1215, D-71144, Steinenbronn, Deutschland
Tel: (49) (0) 7157 20801 Fax: (49) (0) 7157 20813
email: verkauf.deutschland@trumeter.de

Trumeter, 99 rue Parmentier, BP 304, 59666 Villeneuve d'Ascq Cedex, France
Tel: (33) (0) 3 20 59 16 26 Fax: (33) (0) 3 20 59 16 27
email: ventes.france@trumeter.com