

LUXEON M

Brightest, most uniform and highest efficacy multi-die emitter

LUXEON M is an illumination grade multi-die LED designed to enable outdoor and industrial applications targeting either high efficiency or low cost. With *Freedom from Binning* and leading performance, LUXEON M falls within a single 3- or 5-step MacAdam ellipse centered in ANSI to ensure color consistency from LED to LED, delivering high efficacy and high flux density from a uniform source with tight correlated color temperature control. The superior quality of light, volume of lumens, and real world efficacy enable leading performance and efficient solution development in a wide variety of lighting segments.

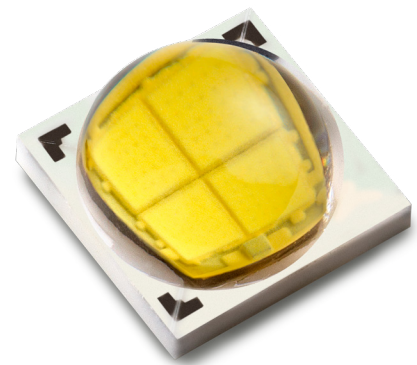

FEATURES AND BENEFITS

Uniform image enables tight beam control in MR16 and spotlight applications

High flux density from a 3mm² area enables reduced emitter count and compact fixture designs

11.2V, 5.6V and 2.8V package options puts high performance within reach with high efficiency and low cost drivers

Leading thermal resistance allows flexible system design to optimize for lm/\$ and lm/W

Exceeds ENERGY STAR® lumen maintenance requirements

PRIMARY APPLICATIONS

Architectural

Downlights

High Bay & Low Bay

Lamps

Outdoor

Specialty Lighting

Spotlights

Table of Contents

General Information	2
Part Number Nomenclature	2
Average Lumen Maintenance Characteristics	3
Environmental Compliance	3
Product Selection	4
Optical and Electrical Characteristics	7
Absolute Maximum Ratings	8
JEDEC Moisture Sensitivity	8
Reflow Soldering Characteristics	9
Mechanical Dimensions	10
Pad Configuration	10
Solder Pad Design	11
Relative Spectral Distribution vs. Wavelength Characteristics	12
Typical Light Output Characteristics	14
Typical Light Output Characteristics	15
Forward Current Characteristics	16
Typical Radiation Patterns	18
Emitter Pocket Tape Packaging	19
Emitter Reel Packaging	20
Product Binning and Labeling	21
Luminous Flux Bins	22
Radiometric Power Bins	22
LUXEON M Color Bin Definition	23

General Information

Part Number Nomenclature

LUXEON M emitters are specified and binned “hot” under conditions comparable to those found in “real-world” lighting products.

The part number designation is explained as follows:

L X R a - b c d e - f g h j

Where:

- a — designates minimum CRI (7 = 70, 8 = 80, 9 = 90, 0 = Royal Blue)
- b — is S for serially connected product with voltage less than 12V; R for series-parallel connected product with voltage less than 6V; Q for parallel connected product with voltage less than 3V.
- c — designates color designation (W = White, R = Royal Blue)
- d, e — designates CCT (27 = 2700K, 30 = 3000K, 35 = 3500K, 40 = 4000K, 50 = 5000K, 57 = 5700K, 65 = 6500K, 00 = Royal Blue)
- fghj — minimum flux lumen (optional)

The test conditions for 12V LUXEON M LX Ra-Scde-fghj are 700mA DC with junction temperature 85°C. The test condition for 6V LUXEON M LX Ra-Rcde-fghj are 1400mA DC with junction temperature 85°C. The test conditions for 3V LUXEON M LX Ra-Qcde-fghj are 2800mA DC with junction temperature 85°C.

Therefore LUXEON M 12V products tested and binned at 700mA follow the part numbering scheme:

L X R 7 - S W 3 0 - x x x x
L X R 7 - S W 4 0 - x x x x
L X R 7 - S W 5 0 - x x x x
L X R 7 - S W 5 7 - x x x x
L X R 7 - S W 6 5 - x x x x
L X R 8 - S W 2 7 - x x x x
L X R 8 - S W 3 0 - x x x x
L X R 8 - S W 3 5 - x x x x
L X R 8 - S W 4 0 - x x x x
L X R 8 - S W 5 0 - x x x x
L X R 9 - S W 2 7 - x x x x
L X R 9 - S W 3 0 - x x x x
L X R 0 - S R 0 0 - x x x x
L X R 9 - S W 5 7 - x x x x

LUXEON M 6V products tested and binned at 1400mA follow the part numbering scheme:

LXR7 - RW30 - xxxx
LXR7 - RW40 - xxxx
LXR7 - RW50 - xxxx
LXR7 - RW57 - xxxx
LXR7 - RW65 - xxxx
LXR8 - RW27 - xxxx
LXR8 - RW30 - xxxx
LXR8 - RW35 - xxxx
LXR8 - RW40 - xxxx
LXR8 - RW50 - xxxx
LXR9 - RW27 - xxxx
LXR9 - RW30 - xxxx
LXR0 - RR00 - xxxx
LXR9 - RW57 - xxxx

LUXEON M 3V products tested and binned at 2800mA follow the part numbering scheme:

LXR7 - QW30 - xxxx
LXR7 - QW40 - xxxx
LXR7 - QW50 - xxxx
LXR7 - QW57 - xxxx
LXR7 - QW65 - xxxx
LXR8 - QW27 - xxxx
LXR8 - QW30 - xxxx
LXR8 - QW35 - xxxx
LXR8 - QW40 - xxxx
LXR8 - QW50 - xxxx
LXR9 - QW27 - xxxx
LXR9 - QW30 - xxxx
LXR0 - QR00 - xxxx
LXR9 - QW57 - xxxx

Average Lumen Maintenance Characteristics

Lumen maintenance for solid-state lighting devices (LEDs) is typically defined in terms of the percentage of initial light output remaining after a specified period of time. Lumileds projects that LUXEON M products will deliver, on average, 70% lumen maintenance (L70) at 50,000 hours of operation at a forward current of up to 700mA for LXR_x-S_{xxxx} and 1400mA for LXR_x-R_{xxxx} and 2800mA for LXR_x-Q_{xxxx}. This projection is based on constant current operation with junction temperature maintained at or below 135°C. This performance is based on Lumileds historical data from tests run on similar material systems, and internal LM80 and reliability testing. Observation of design limits included in this data sheet is required in order to achieve this projected lumen maintenance.

Environmental Compliance

Lumileds is committed to providing environmentally friendly products to the solid-state lighting market. LUXEON M is compliant to the European Union directives on the restriction of hazardous substances in electronic equipment, namely the RoHS directive. Lumileds will not intentionally add the following restricted materials to the LUXEON M lead, mercury, cadmium, hexavalent chromium, polybrominated biphenyls (PBB) or polybrominated diphenyl ethers (PBDE).

Product Selection

Product Selection Guide for LUXEON M 12V White Junction Temperature = 85°C

Table 1.

Performance Characteristics at 700mA for LXR _x -SW _{xx} Products				
Nominal CCT	Part Number	Minimum CRI	Minimum Luminous Flux (lm)	Typical Luminous Flux (lm)
3000K	LXR7-SW30	70	900	1000
4000K	LXR7-SW40	70	970	1076
5000K	LXR7-SW50	70	1040	1100
5700K	LXR7-SW57	70	1040	1110
6500K	LXR7-SW65	70	1040	1130
2700K	LXR8-SW27	80	730	800
3000K	LXR8-SW30	80	780	850
3500K	LXR8-SW35	80	780	870
4000K	LXR8-SW40	80	840	905
5000K	LXR8-SW50	80	840	920
2700K	LXR9-SW27	90	600	660
3000K	LXR9-SW30	90	640	736
5700K	LXR9-SW57	90	800	880

Notes for Table 1:

1. Lumileds maintains a tolerance of ±6.5% on flux measurements and ±2 on CRI.

Product Selection Guide for LUXEON M 12V Royal Blue Junction Temperature = 85°C

Table 2.

Performance Characteristics at 700mA for LXR0-SR _{xx} 00 Products				
Color	Part Number	Minimum Radiometric Power (mW)	Typical Radiometric Power (mW)	Typical Radiant Efficacy (%)
Royal Blue	LXR0-SR00	4200	4500	57.4

Note for Table 2:

1. Lumileds maintains a tolerance of ±6.5% on flux measurements.
2. Test current is 700mA for LXR0-SR00 products.

Product Selection Guide for LUXEON M 6V White

Junction Temperature = 85°C

Table 3.

Performance Characteristics at 1400mA for LXR _x -RW _{xx} Products				
Nominal CCT	Part Number	Minimum CRI	Minimum Luminous Flux (lm)	Typical Luminous Flux (lm)
3000K	LXR7-RW30	70	900	1000
4000K	LXR7-RW40	70	970	1076
5000K	LXR7-RW50	70	1040	1100
5700K	LXR7-RW57	70	1040	1110
6500K	LXR7-RW65	70	1040	1130
2700K	LXR8-RW27	80	730	800
3000K	LXR8-RW30	80	780	850
3500K	LXR8-RW35	80	780	870
4000K	LXR8-RW40	80	840	920
5000K	LXR8-RW50	80	840	920
2700K	LXR9-RW27	90	600	660
3000K	LXR9-RW30	90	640	736
5700K	LXR9-RW57	90	800	880

Notes for Table 3:

1. Lumileds maintains a tolerance of ±6.5% on flux measurements and ±2 on CRI.

Product Selection Guide for LUXEON M 6V Royal Blue

Junction Temperature = 85°C

Table 4.

Performance Characteristics at 1400mA for LXR0-RR00 Products				
Color	Part Number	Minimum Radiometric Power (mW)	Typical Radiometric Power (mW)	Typical Radiant Efficacy (%)
Royal Blue	LXR0-RR00	4200	4500	57.4

Note for Table 4:

1. Lumileds maintains a tolerance of ±6.5% on flux measurements.

Product Selection Guide for LUXEON M 3V White Junction Temperature = 85°C

Table 5.

Performance Characteristics at 2800mA for LXR0-QR00 Products				
Nominal CCT	Part Number	Minimum CRI	Minimum Luminous Flux (lm)	Typical Luminous Flux (lm)
3000K	LXR7-QW30	70	900	1000
4000K	LXR7-QW40	70	970	1076
5000K	LXR7-QW50	70	1040	1100
5700K	LXR7-QW57	70	1040	1110
6500K	LXR7-QW65	70	1040	1130
2700K	LXR8-QW27	80	730	800
3000K	LXR8-QW30	80	780	850
3500K	LXR8-QW35	80	780	870
4000K	LXR8-QW40	80	840	920
5000K	LXR8-QW50	80	840	920
2700K	LXR9-QW27	90	600	660
3000K	LXR9-QW30	90	640	736
5700K	LXR9-QW57	90	800	880

Notes for Table 5:

1. Lumileds maintains a tolerance of $\pm 6.5\%$ on flux measurements and ± 2 on CRI.

Product Selection Guide for LUXEON M 3V Royal Blue Junction Temperature = 85°C

Table 6.

Performance Characteristics at 2800mA for LXR0-QR00 Products				
Color	Part Number	Minimum Radiometric Power (mW)	Typical Radiometric Power (mW)	Typical Radiant Efficacy (%)
Royal Blue	LXR0-QR00	4200	4500	57.4

Note for Table 6:

1. Lumileds maintains a tolerance of $\pm 6.5\%$ on flux measurements.

Optical and Electrical Characteristics

LUXEON M White at Test Current ^[1], Junction Temperature = 85°C

Table 7.

Nominal CCT	Part Number	Color Temperature ^[2] CCT Typical (K)	Typ Total Included Angle ^[2] (°C) u0.90V	Typ Viewing Angle ^[3] (°C) 2θ 1/2
2700K	LXR8-SW27, LXR8-RW27, LXR8-QW27	2725	140	120
	LXR9-SW27, LXR9-RW27, LXR9-QW27	2725	140	120
3000K	LXR7-SW30, LXR7-RW30, LXR7-QW30	3045	140	120
	LXR8-SW30, LXR8-RW30, LXR8-QW30	3045	140	120
	LXR9-SW30, LXR9-RW30, LXR9-QW30	3045	140	120
3500K	LXR8-SW35, LXR8-RW35, LXR8-QW35	3465	140	120
4000K	LXR7-SW40, LXR7-RW40, LXR7-QW40	3985	140	120
	LXR8-SW40, LXR8-RW40, LXR8-QW40	3985	140	120
5000K	LXR7-SW50, LXR7-RW50, LXR7-QW50	5028	140	120
	LXR8-SW50, LXR8-RW50, LXR8-QW50	5028	140	120
5700K	LXR7-SW57, LXR7-RW57, LXR7-QW57,	5665	140	120
	LXR9-SW57, LXR9-RW57, LXR9-QW57	5665	140	120
6500K	LXR7-SW65, LXR7-RW65, LXR7-QW65	6530	140	120

Notes for Table 7:

1. Test current is 700mA for LXRx-SWxx, 1400mA for LXRx-RWxx and 2800mA for LXRx-QWxx products.
2. Total included angle at which 90% of total luminous flux is captured.
3. Viewing angle is the off axis angle from lamp centerline where the luminous intensity is 1/2 of the peak value.

LUXEON M Royal Blue at Test Current ^[1], Junction Temperature = 85°C

Table 8.

Color	Peak Wavelength, λ_p ^[2]			Typical Spectral Half-width (nm) ^[3] $\Delta\lambda_{1/2}$	Typ. Temperature Coefficient of Peak Wavelength (nm/°C) $\Delta\lambda_p / \Delta T_J$	Typ. Total Included Angle (°C) ^[4] θ_{90V}	Typical Viewing Angle (°C) ^[5] $2\theta_{1/2}$
	Minimum	Typical	Maximum				
Royal Blue	445.0 nm	447.5nm	460.0nm	22	0.05	140	150

Notes for Table 8:

1. Test current is 700mA for LXRO-SR00, 1400mA for LXRO-RR00 and 2800mA for LXRO-QR00.
2. Royal Blue product is binned by radiometric power and peak wavelength rather than photometric lumens.
3. Spectral half-width is 1/2 of the peak intensity.
4. Total included angle at which 90% of total radiometric power is captured.
5. Viewing angle is the off axis angle from lamp centerline where the luminous intensity is 1/2 of the peak value.

Electrical Characteristics for LUXEON M at Test Current ^[1], Junction Temperature = 85°C for all CCTs and Royal Blue

Table 9.

Part Number	Forward Voltage V_f ^[1, 2] (V) $I_f = 700\text{mA}, 1400\text{mA}$ and 2800mA			Typical Temperature Coefficient of Forward Voltage ^[3] (mV/°C) $\Delta V_f / \Delta T_j$	Typical Thermal Resistance Junction to Thermal Pad (°C/W) $R_{\theta_{j-c}}$
	Minimum	Typical	Maximum		
LXRx-Sxxx	10.5	11.2	11.7	-5.5	1.25
LXRx-Rxxx	5.25	5.6	6	-2.75	1.25
LXRx-Qxxx	2.63	2.8	3	-1.38	1.25

Notes for Table 9:

1. Test current is 700mA for LXRx-Sxxx, 1400mA for LXRx-Rxxx and 2800mA for LXRx-Qxxx products.
2. Lumileds maintains a tolerance of $\pm 0.06\text{V}$ on forward voltage measurements.
3. Measured between $T_j = 25^\circ\text{C}$ and $T_j = 135^\circ\text{C}$.

Absolute Maximum Ratings

Table 10.

Parameter	Maximum Performance
DC Forward Current (mA) ^{[1], [2]}	1200mA for LXR7-Sxxx, LXR8-Sxxx, LXR9-Sxxx; 2400mA for LXR7-Rxxx, LXR8-Rxxx, LXR9-Rxxx; 4800mA for LXR7-Qxxx, LXR8-Qxxx, LXR9-Qxxx; 1050mA for LXRO-Sxxx; 2100mA for LXRO-Rxxx; 4200mA for LXRO-Qxxx
Peak Pulsed Forward Current ^{[1], [3]}	1375mA for LXR7-Sxxx, LXR8-Sxxx, LXR9-Sxxx; 2750mA for LXR7-Rxxx, LXR8-Rxxx, LXR9-Rxxx; 5500mA for LXR7-Qxxx, LXR8-Qxxx, LXR9-Qxxx; 1200mA for LXRO-Sxxx; 2400mA for LXRO-Rxxx; 4800mA for LXRO-Qxxx
ESD Sensitivity	$\leq 8000\text{V}$ Human Body Model (HBM) Class 3B JS-001-2012 $< 400\text{V}$ Machine Model (MM) Class B JESD22-A115-B
LED Junction Temperature ^[1]	135°C
Operating Case Temperature at Current	-40°C - 120°C @ 700mA for LXRx-Sxxx -40°C - 120°C @ 1400mA for LXRx-Rxxx -40°C - 120°C @ 2800mA for LXRx-Qxxx
Storage Temperature	-40°C - 120°C
Lead Soldering Temperature	JEDEC 020c 260°C
Allowable Reflow Cycles	3
Autoclave Conditions	121°C at 2 ATM 100% Relative Humidity for 96 Hours Maximum
Reverse Voltage (V _r)	LUXEON M LEDs are not designed to be driven in reverse bias

Notes for Table 10:

1. Proper current derating must be observed to maintain junction temperature below the maximum.
2. Residual periodic variations due to power conversion from alternating current (AC) to direct current (DC), also called "ripple", with frequencies $\geq 100\text{Hz}$ and amplitude $\leq 1200\text{mA}$ for LXRO-Sxxx, $\leq 2400\text{mA}$ for LXRO-Rxxx and $\leq 4800\text{mA}$ for LXRO-Qxxx products are acceptable, assuming the average current throughout each cycle does not exceed 1050mA for LXRO-Sxxx, 2100mA for LXRO-Rxxx and 4200mA for LXRO-Qxxx.
3. Pulsed operation with a peak drive current of 1200mA for LXRO-Sxxx, 2400mA for LXRO-Rxxx and 4800mA for LXRO-Qxxx are acceptable if the pulse on time is $\leq 5\text{ms}$ per cycle and the duty cycle is $\leq 50\%$.
4. Residual periodic variations due to power conversion from alternating current (AC) to direct current (DC), also called "ripple", with frequencies $\geq 100\text{Hz}$ and amplitude $\leq 1375\text{mA}$ for LXR7-Sxxx, LXR8-Sxxx, LXR9-Sxxx, $\leq 2750\text{mA}$ for LXR7-Rxxx, LXR8-Rxxx, LXR9-Rxxx and $\leq 5500\text{mA}$ for LXR7-Qxxx, LXR8-Qxxx, LXR9-Qxxx products are acceptable, assuming the average current throughout each cycle does not exceed 1200mA for LXR7-Sxxx, LXR8-Sxxx, LXR9-Sxxx, 2400mA for LXR7-Rxxx, LXR8-Rxxx, LXR9-Rxxx and 4800mA for LXR7-Qxxx, LXR8-Qxxx, LXR9-Qxxx.
5. Pulsed operation with a peak drive current of 1370mA for LXR7-Sxxx, LXR8-Sxxx, LXR9-Sxxx, 2750mA for LXR7-Rxxx, LXR8-Rxxx, LXR9-Rxxx and 5500mA for LXR7-Qxxx, LXR8-Qxxx, LXR9-Qxxx are acceptable if the pulse on time is $\leq 5\text{ms}$ per cycle and the duty cycle is $\leq 50\%$.

JEDEC Moisture Sensitivity

Table 11.

Level	Floor Life		Soak Requirements	
	Time	Conditions	Time	Conditions
1	Unlimited	$\leq 30^\circ\text{C} / 85\% \text{RH}$	168 Hrs. + 5 / -0 Hrs.	85°C / 85% RH

Reflow Soldering Characteristics

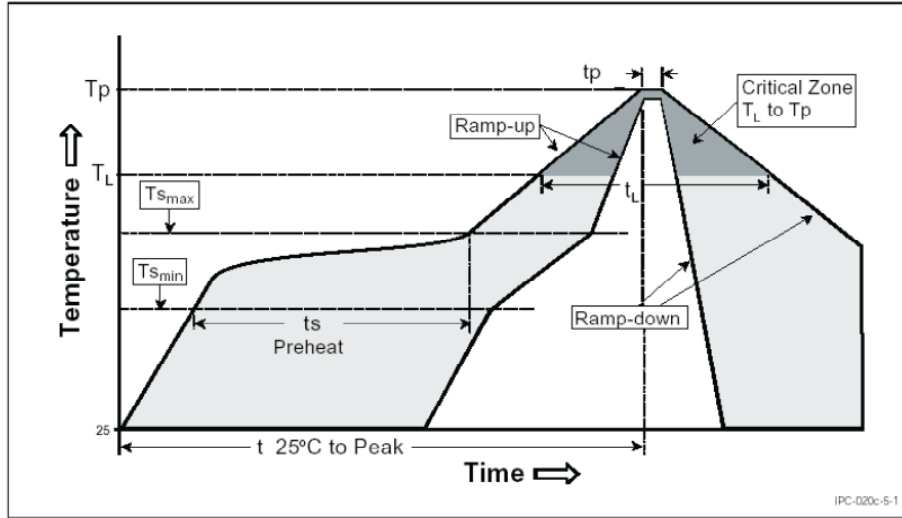

Figure 1. Temperature Profile for Table 12.

Table 12.

Profile Feature	Lead Free Assembly
Average Ramp-Up Rate ($T_{s_{max}}$ to T_p)	3°C / second max
Preheat Temperature Min ($T_{s_{min}}$)	150°C
Preheat Temperature Max ($T_{s_{max}}$)	200°C
Preheat Time ($t_{s_{min}}$ to $t_{s_{max}}$)	60 - 180 seconds
Time Maintained Above Temperature T_L	217°C
Time Maintained Above Time (t_L)	60 - 150 seconds
Peak / Classification Temperature (T_p)	260°C
Time Within 5°C of Actual Peak Temperature (t_p)	20 - 40 seconds
Ramp-Down Rate	6°C / second
Time 25°C to Peak Temperature	8 minutes max

Note for Table 12:

- All temperatures refer to the application Printed Circuit Board (PCB), measured on the surface adjacent to the package body.

Mechanical Dimensions

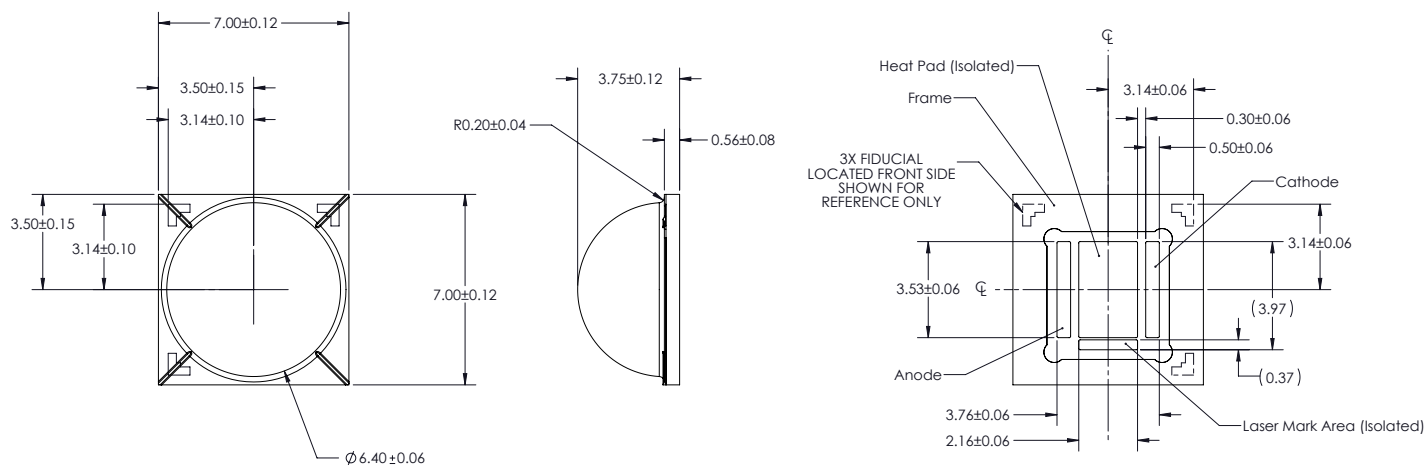

Figure 2. Package outline drawing.

Notes for Figure 2:

1. Do not handle the device by the lens. Excessive force on the lens may damage the lens itself or the interior of the device.
2. All dimensions are in millimeters.
3. Drawings not to scale.
4. The thermal pad is electrically isolated from the anode and cathode contact pads.

Pad Configuration

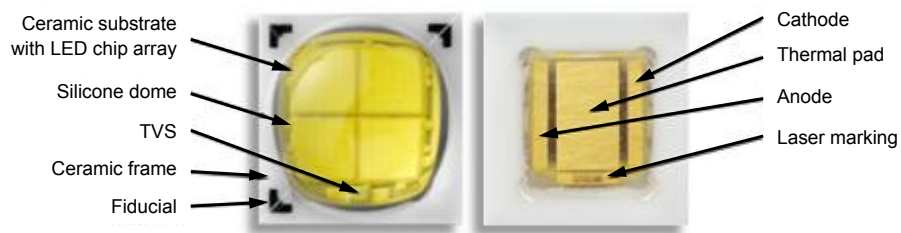

Figure 3. Pad configuration.

Note for Figure 3:

1. The thermal pad is electrically isolated from the anode and cathode contact pads.

Solder Pad Design

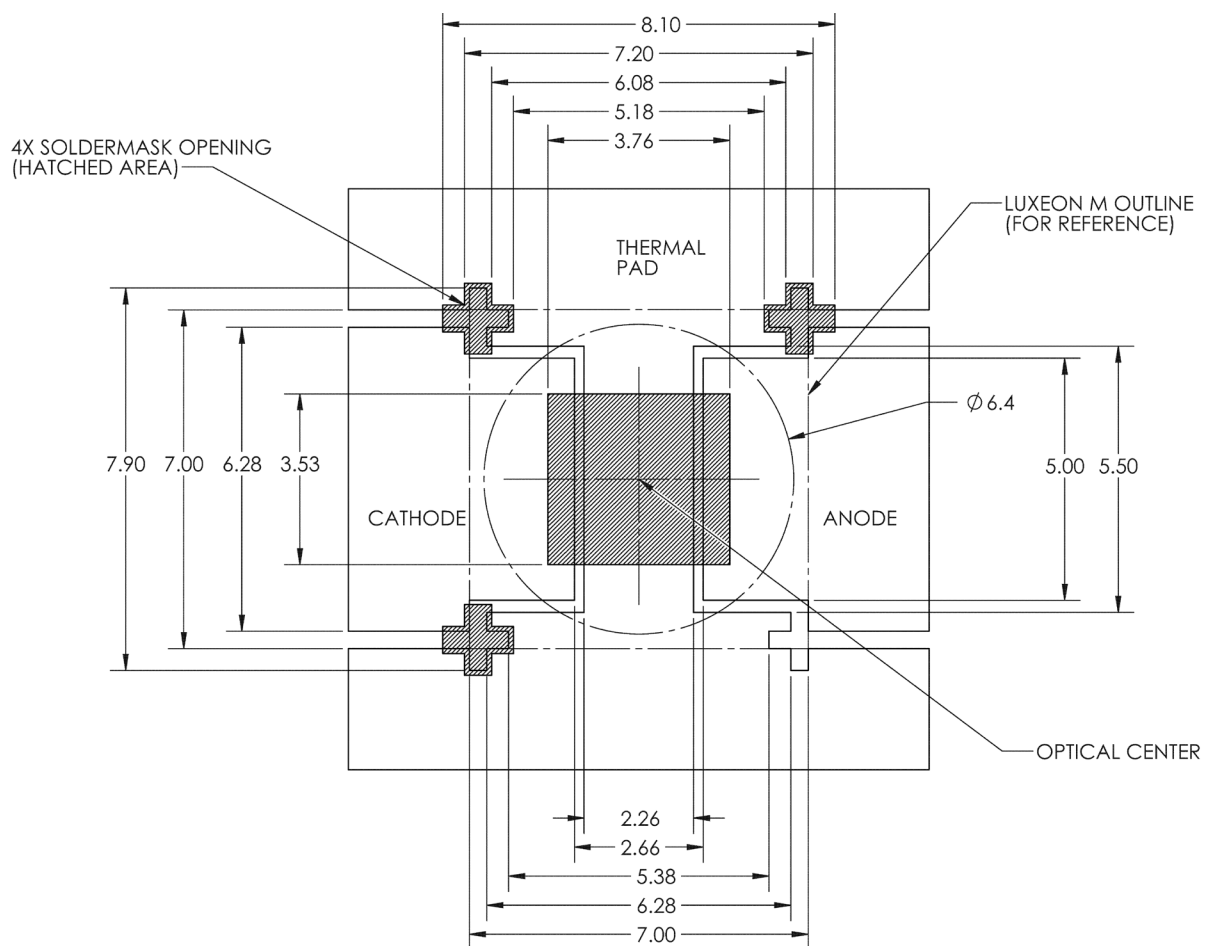

Figure 4. Recommended LUXEON M footprint design for Metal Core PCB. All dimensions are in millimeters.

Notes for Figure 4:

1. The LUXEON M Application Brief provides extensive details for this layout.
2. Printed Circuit Board layout files (.dwg) are available at www.lumileds.com.

Relative Spectral Distribution vs. Wavelength Characteristics

LXR7-xWxx (White) at Test Current, Junction Temperature = 85°C

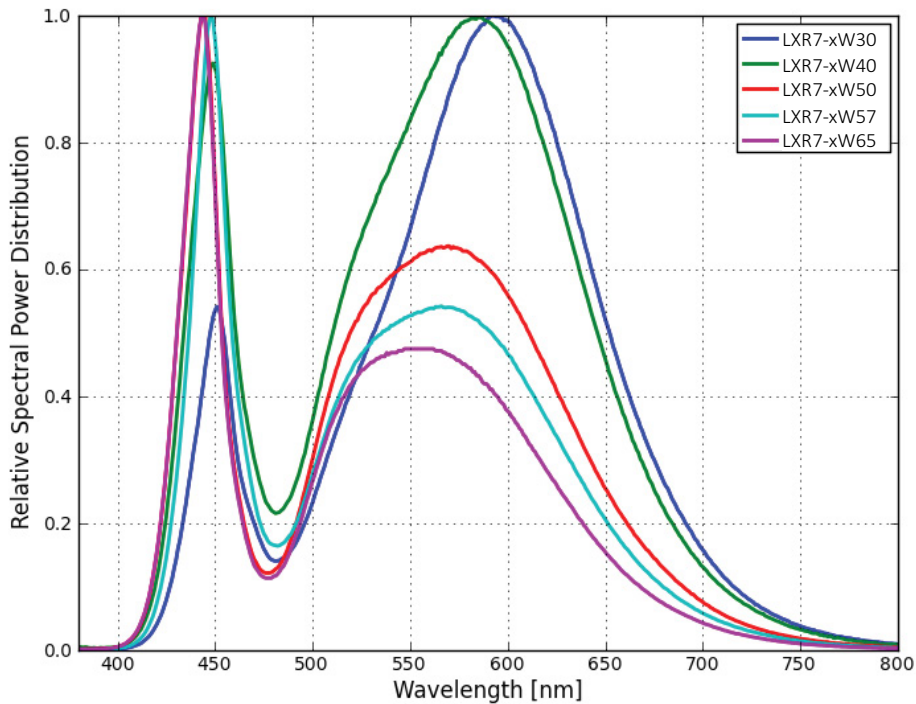

Figure 5. Color spectrum of LXR7-xWxx emitter, integrated measurement.

LXR8-xWxx (White) at Test Current, Junction Temperature = 85°C

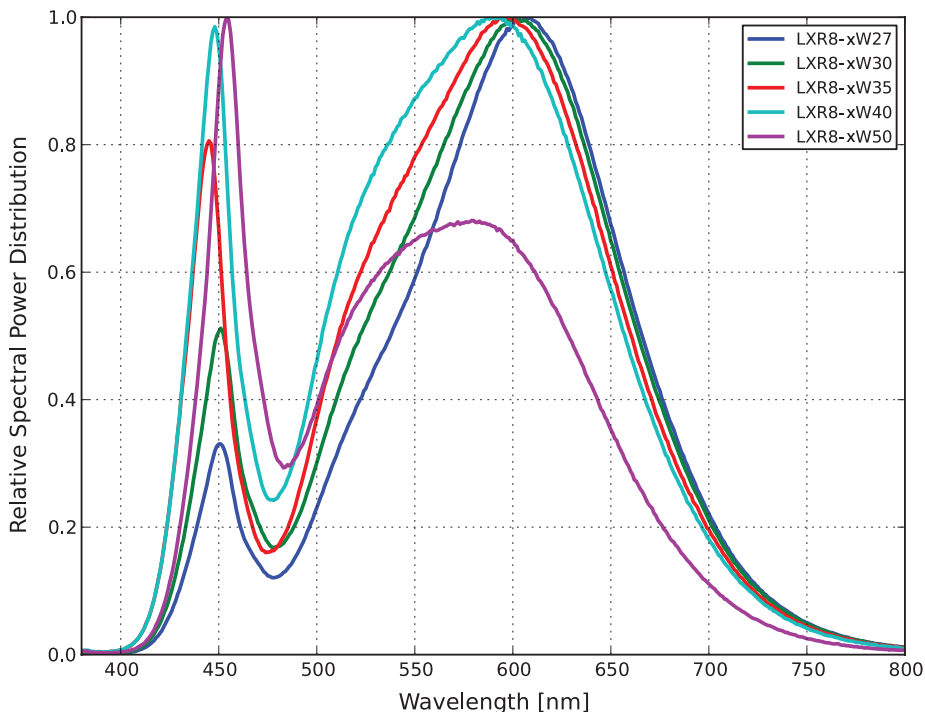

Figure 6. Color spectrum of LXR8-xWxx emitter, integrated measurement.

LXR9-xWxx (White) at Test Current, Junction Temperature = 85°C

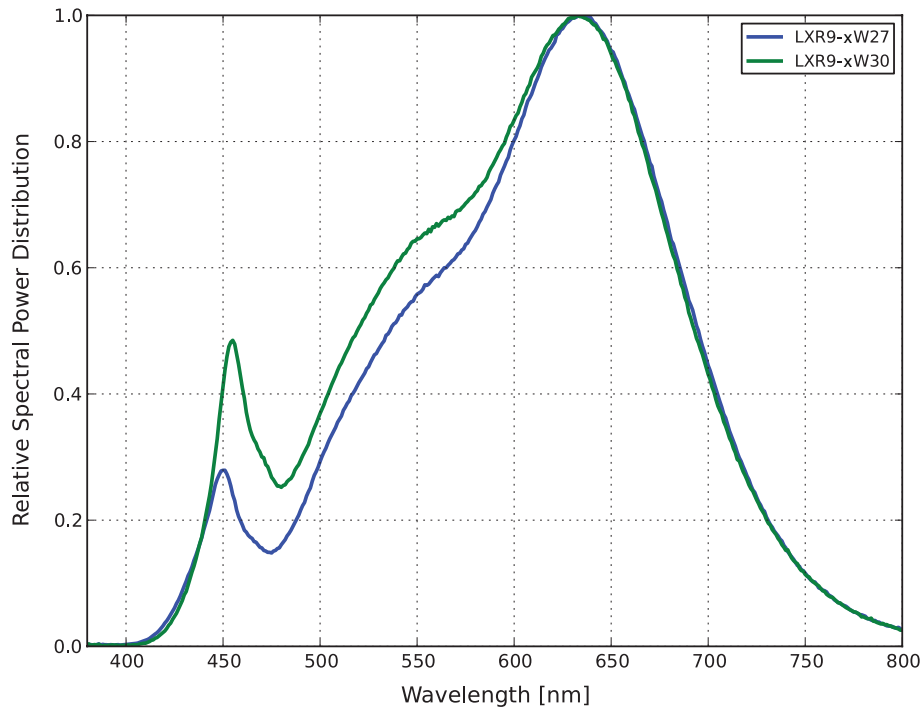

Figure 7. Color spectrum of LXR9-xWxx emitter, integrated measurement.

LXR0-xR00 (Royal Blue) at Test Current, Junction Temperature = 85°C

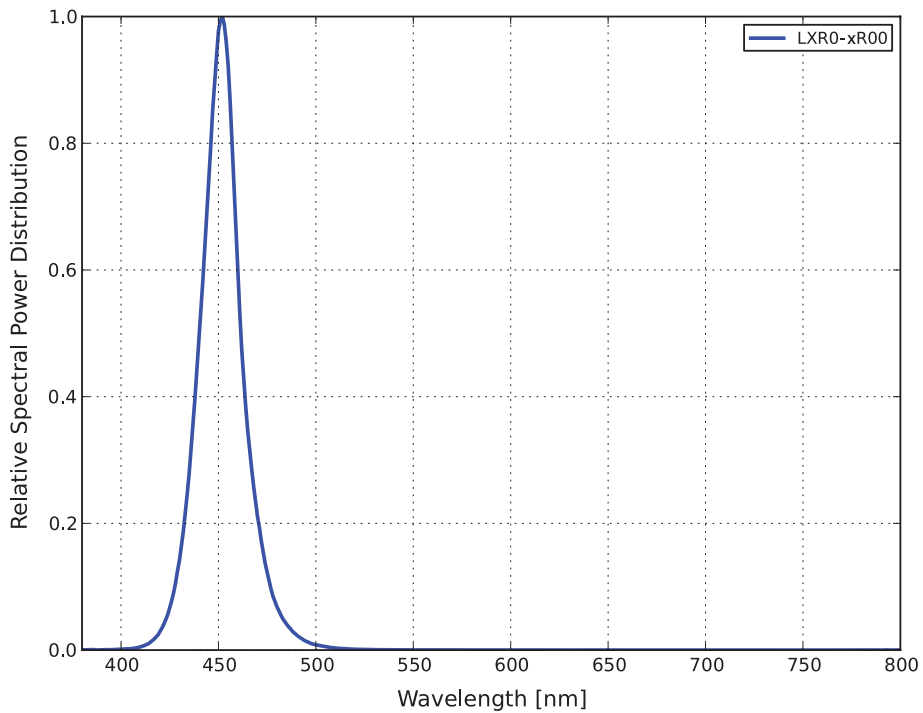

Figure 8. Color spectrum of LXR0-xR00 emitter, integrated measurement.

Typical Light Output Characteristics

Typical Relative Light Output Characteristics over Temperature at Test Current of 700mA, 1400mA and 2800mA for LXR_x-xW_{xx} (White) and LXRO-xR00 (Royal Blue)

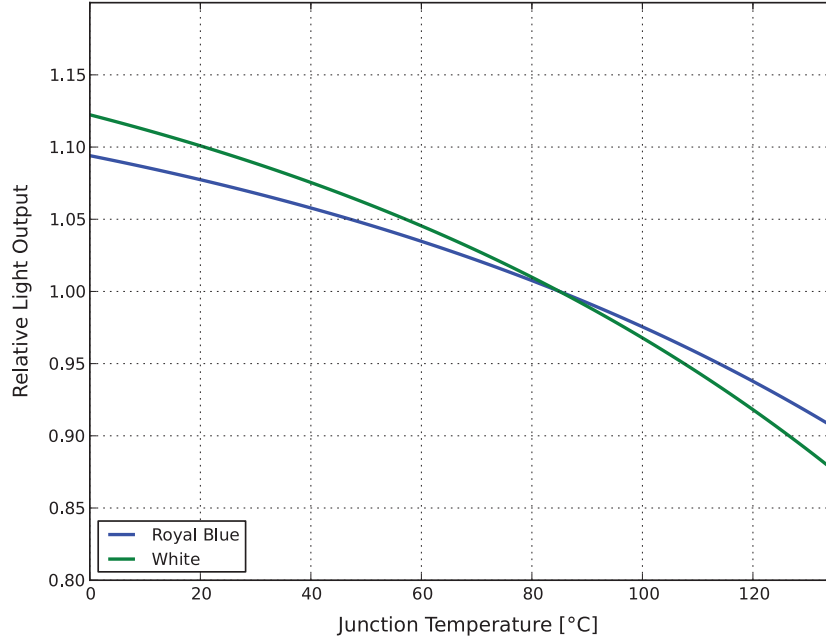

Figure 9. Relative light output vs. junction temperature.

Typical Relative Luminous Flux vs. Forward Current, Junction Temperature = 85°C for LXR_x-SW_{xx} (White) and LXRO-SR00 (Royal Blue)

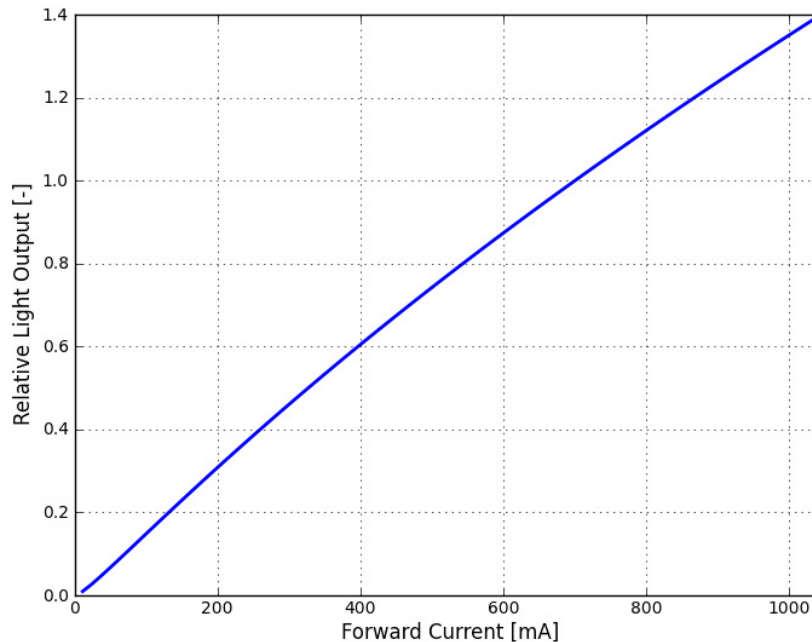

Figure 10. Relative light output vs. forward current (12V).

Typical Light Output Characteristics

Typical Relative Luminous Flux vs. Forward Current, Junction Temperature = 85°C for LXR_x-RW_{xx} (White) and LXR0-RR00 (Royal Blue)

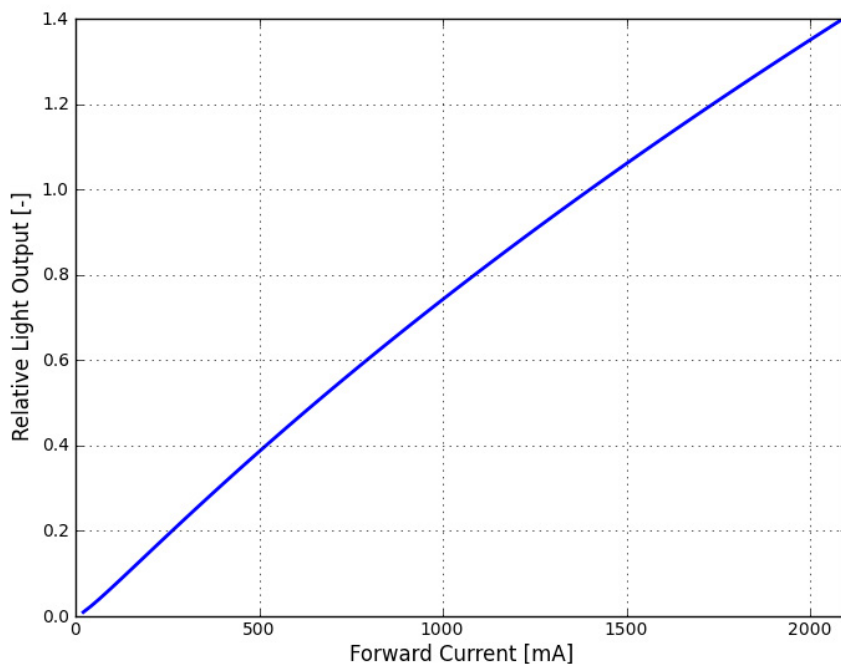

Figure 11. Relative light output vs. forward current (6V).

Typical Relative Luminous Flux vs. Forward Current, Junction Temperature = 85°C for LXR_x-QW_{xx} (White) and LXR0-QR00 (Royal Blue)

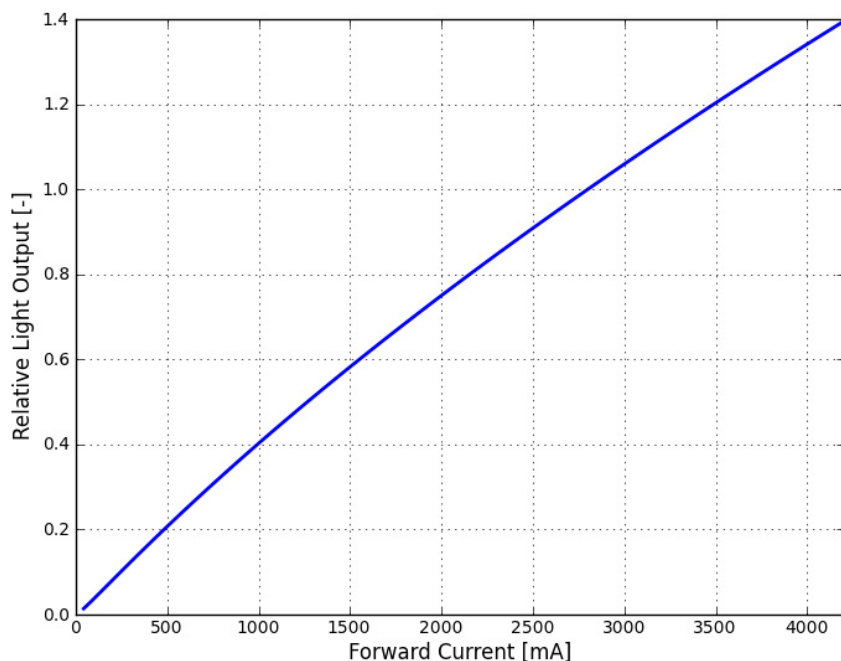

Figure 12. Relative light output vs. forward current (3V).

Forward Current Characteristics

Typical Forward Current vs. Forward Voltage, Junction Temperature = 85°C for LXR_x-SW_{xx} (White) and LXR0-SR00 (Royal Blue)

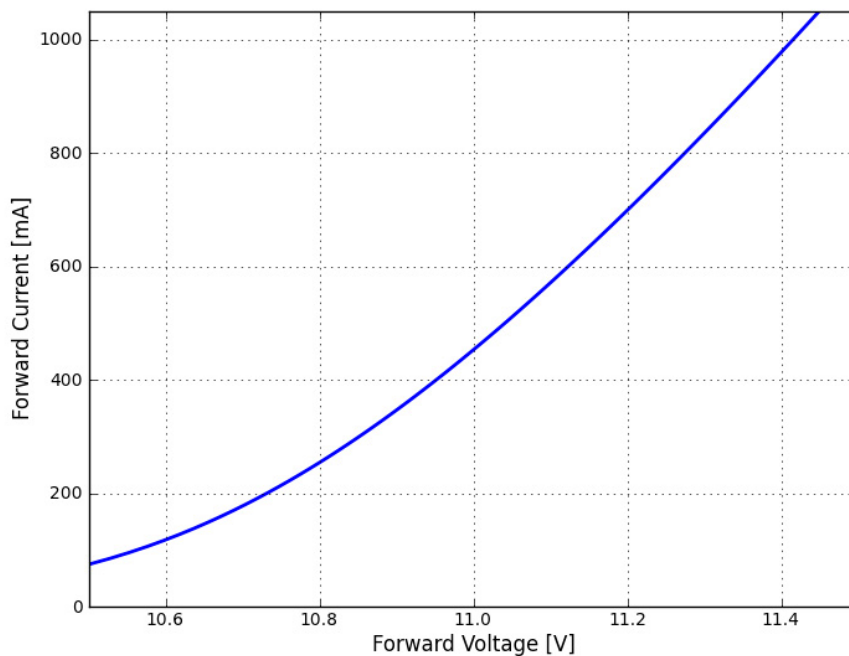

Figure 13. Forward current vs. forward voltage (12V).

Typical Forward Current vs. Forward Voltage, Junction Temperature = 85°C for LXR_x-RW_{xx} (White) and LXR0-RR00 (Royal Blue)

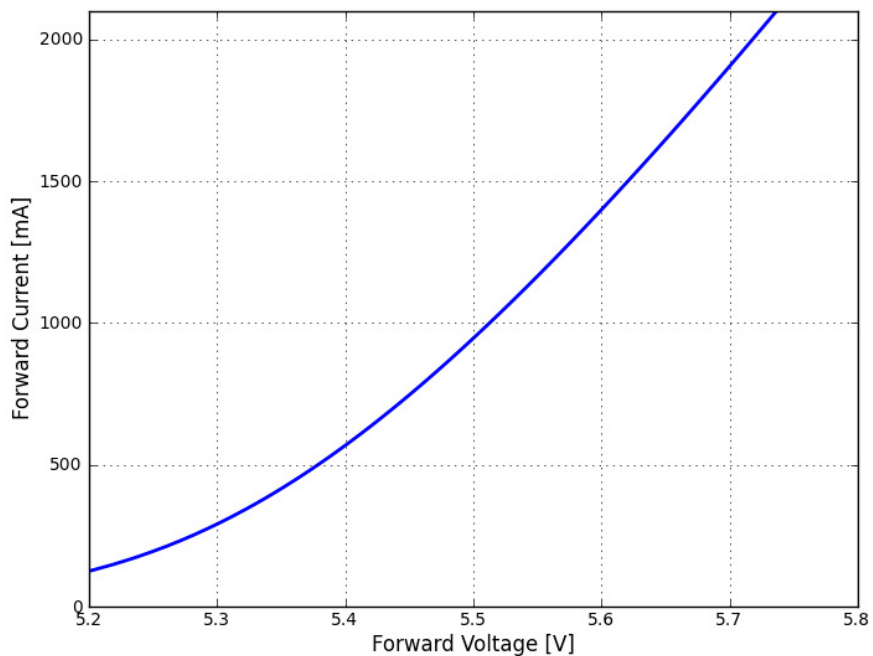

Figure 14. Forward current vs. forward voltage (6V).

Typical Forward Current vs Forward Voltage, Junction Temperature = 85°C
for LXR_x-QW_{xx} (White) and LXR0-QR00 (Royal Blue)

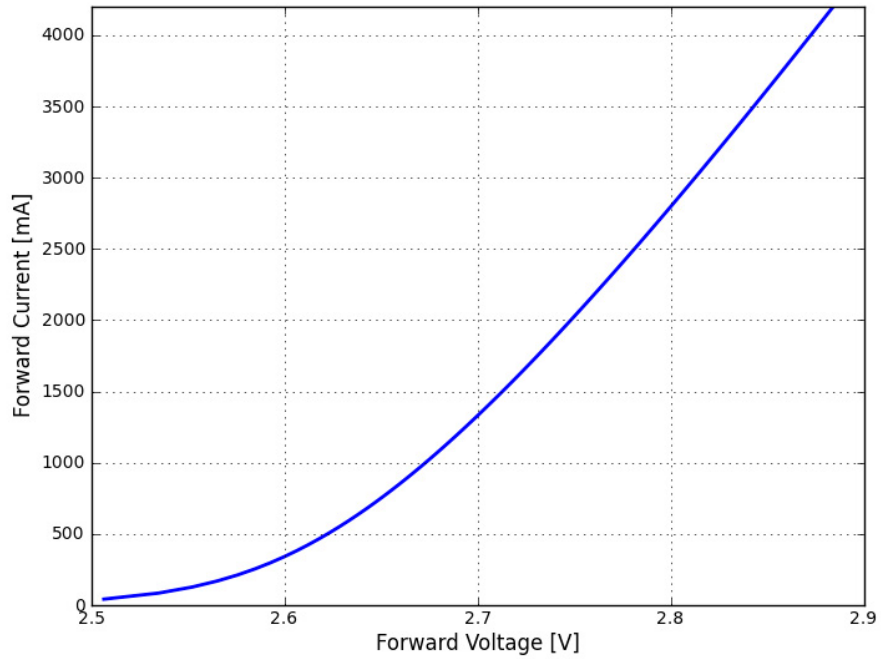

Figure 15. Forward current vs. forward voltage (3V).

Typical Radiation Patterns

Typical Spatial Radiation Pattern for LXR_x-xW_{xx} (White) and LXR0-xR00 (Royal Blue)

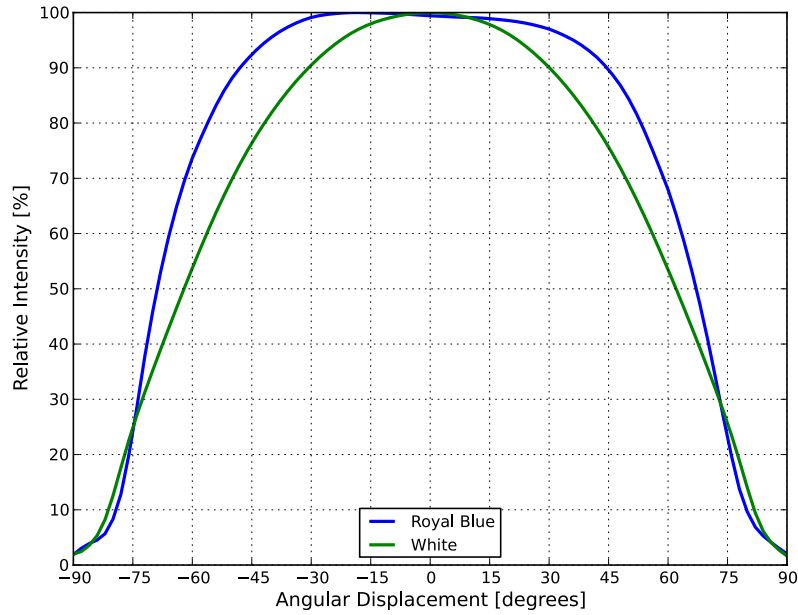

Figure 16. Typical representative spatial radiation pattern.

Typical Polar Radiation Pattern for LXR_x-xW_{xx} (White) and LXR0-xR00 (Royal Blue)

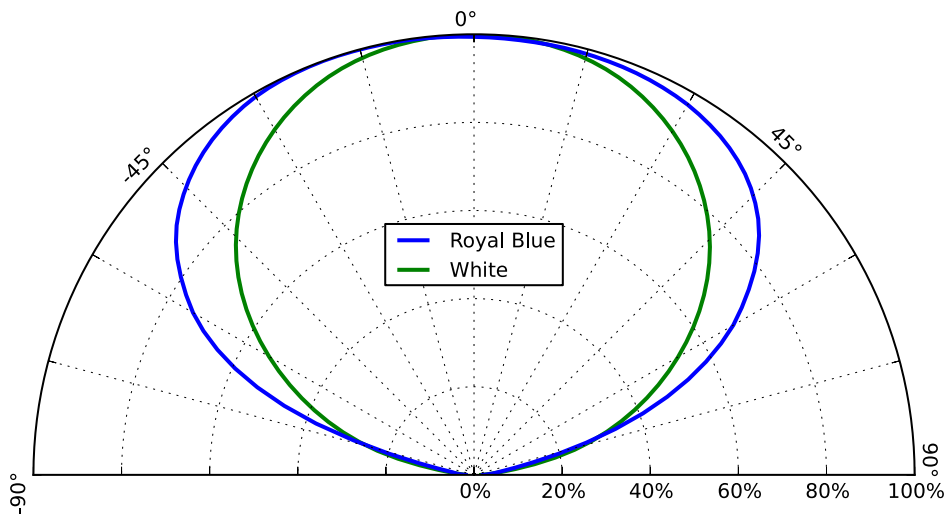

Figure 17. Typical polar radiation pattern.

Emitter Pocket Tape Packaging

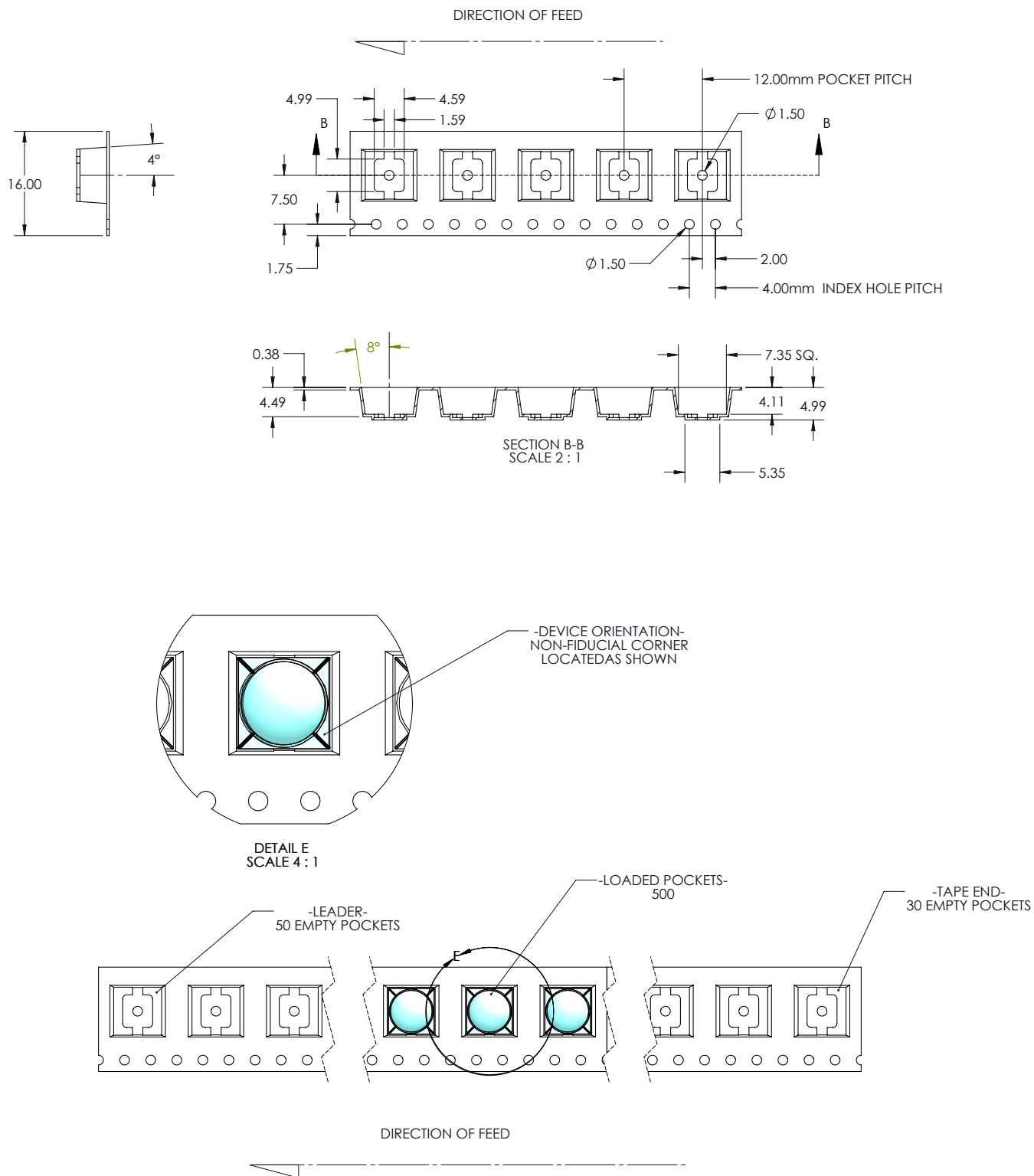

Figure 18. Emitter pocket tape packaging.

Emitter Reel Packaging

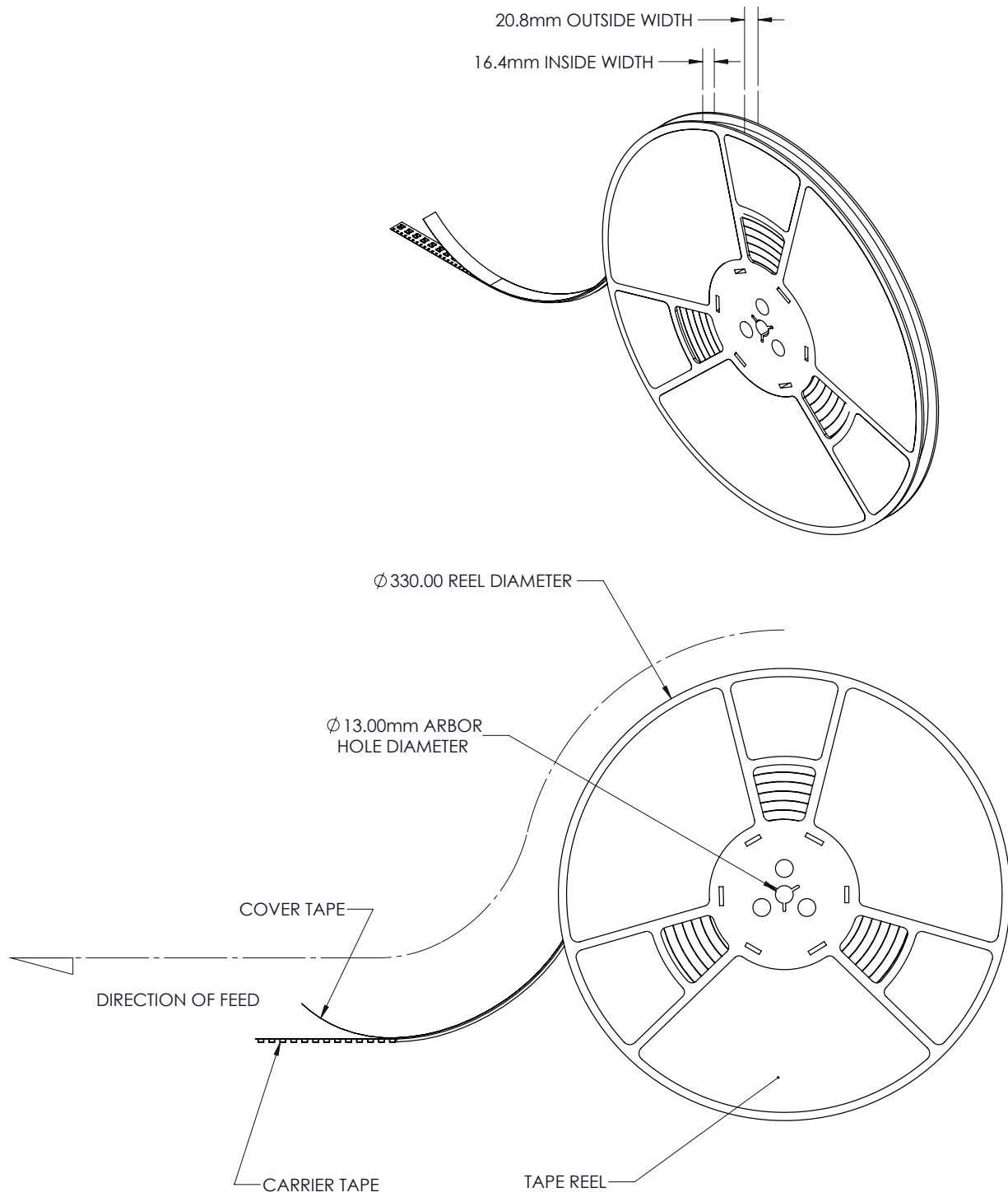

Figure 19. Emitter reel packaging.

Product Binning and Labeling

Purpose of Product Binning

In the manufacturing of semiconductor products, there is a variation of performance around the average values given in the technical data sheets. For this reason, Lumileds bins the LED components for luminous flux, color, and forward voltage (V_f).

Decoding Product Bin Labeling

Reels with LUXEON M White emitters are labeled with a four digit alphanumeric code (CAT code) following the format below. All emitters packaged within a reel are of the same 4-variable bin combination.

For LXR x -xW xx , Reels of emitters are labeled with a four digit alphanumeric CAT code following the format below.

ABCD

A = Luminous flux bin (See table 9)

B = Color or CCT indication (1 for 6500K, 2 for 5700K, 3 for 5000K, 5 for 4000K, 6 for 3500K, 7 for 3000K, and 8 for 2700K)

C = Color consistency (5 for within 5-step MacAdam Ellipse, 3 for within 3-step MacAdam Ellipse). Detailed definitions for these color bins can be found in Table 15.

D = V_f bin (F,G,H)

Reels with LUXEON M Royal Blue emitters are labeled with a three digit alphanumeric CAT code following the format below. All emitters packaged within a reel are of the same 4-variable bin combination.

ABC

A = Radiometric Power Bin (See table 10)

B = Peak wavelength bin (See table 12)

C = V_f bin (F,G,H)

Luminous Flux Bins

Table 13 lists the standard photometric luminous flux bins for LUXEON M white emitters (LXR_x-xW_{xx}). Test conditions for LXR_x-SW_{xx} are 700mA and junction temperature 85°C. Test conditions for LXR_x-RW_{xx} are 1400mA and junction temperature 85°C.

Although several bins are outlined, product availability in a particular bin varies by production run and by product performance.

Table 13. Luminous Flux Bins for White

Bin Code	Minimum Photometric Flux (lm)	Maximum Photometric Flux (lm)
J	510	550
K	550	590
L	590	630
M	630	680
N	680	730
P	730	780
Q	780	840
R	840	900
S	900	970
T	970	1040
U	1040	1120
V	1120	1200
W	1200	1290

Radiometric Power Bins

Table 14 lists the standard radiometric flux bins for LUXEON M Royal Blue emitters LXRO-SR00, LXRO-RR00 and LXRO-QW00. Test conditions for LXRO-SR00 are 700mA, LXRO-RR00 are 1400mA and LXRO-QR00 are 2800mA, all at junction temperature 85°C.

Table 14. Radiometric Power Bins for Royal Blue

Bin Code	Minimum Radiometric Flux (mW)	Maximum Radiometric Flux (mW)
A	4000	4200
B	4200	4400
C	4400	4600
D	4600	4800
E	4800	5000

LUXEON M Color Bin Definition

LUXEON M 3- and 5-step MacAdam Ellipse White Color Bin Definition for LXR_x-SW_{xx} and LXR_x-QW_{xx}

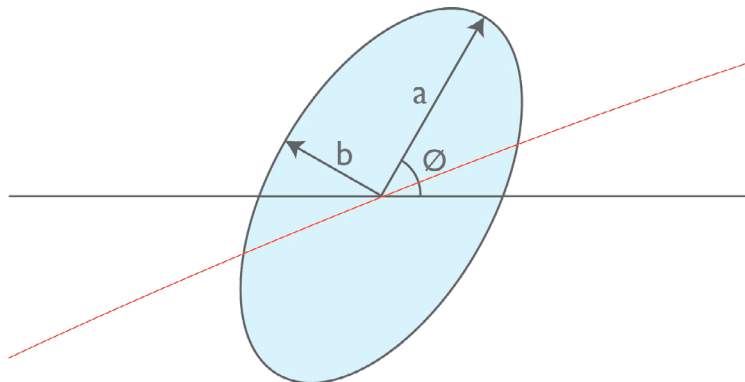

Table 15. LUXEON M Color Bin Definitions

Nominal ANSI CCT	Color Space	Center Point (cx, cy)	Major Axis, a	Minor Axis, b	Ellipse Rotation Angle (degrees)
3000K	Single 5-step MacAdam ellipse	0.4338, 0.4030	0.01390	0.00680	53.22
4000K	Single 5-step MacAdam ellipse	0.3818, 0.3797	0.01565	0.00670	53.72
5000K	Single 5-step MacAdam ellipse	0.3447, 0.3553	0.01370	0.00590	59.62
5700K	Single 5-step MacAdam ellipse	0.3287, 0.3417	0.01243	0.00533	59.09
6500K	Single 5-step MacAdam ellipse	0.3123, 0.3282	0.01115	0.00475	58.57
2700K	Single 3-step MacAdam ellipse	0.4578, 0.4101	0.00810	0.00420	53.70
3000K	Single 3-step MacAdam ellipse	0.4338, 0.4030	0.00834	0.00408	53.22
3500K	Single 3-step MacAdam ellipse	0.4073, 0.3917	0.00927	0.00414	54.00
4000K	Single 3-step MacAdam ellipse	0.3818, 0.3797	0.00939	0.00402	53.72
5000K	Single 3-step MacAdam ellipse	0.3447, 0.3553	0.00822	0.00354	59.62

Notes for Table 15:

1. Lumileds maintains a tester tolerance of ± 0.005 on x, y color coordinates.
2. Tested at binning current and Junction Temperature = 85°C.

Peak Wavelength Bin Definition for LXRO-SR00 and LXRO-RR00

Table 16. Peak Wavelength Bin Structure for Royal Blue

Bin Code	Minimum Peak Wavelength (nm)	Maximum Peak Wavelength (nm)
4	445	450
5	450	455
6	455	460

Forward Voltage Bins

Tables 17 and 18 list minimum and maximum V_f bin values per emitter. Although several bins are outlined, product availability in a particular bin varies by production run and by product performance.

Table 17. Forward Voltage Bins for LXR_x-SW_{xx} and LXRO-SR00

Bin Code	Minimum Forward Voltage (V)	Maximum Forward Voltage (V)
F	10.5	11.0
G	11.0	11.5
H	11.5	11.7

Table 18. Forward Voltage Bins for LXR_x-RW_{xx} and LXRO-RR00

Bin Code	Minimum Forward Voltage (V)	Maximum Forward Voltage (V)
F	5.25	5.50
G	5.50	5.75
H	5.75	6.00

Table 19. Forward Voltage Bins for LXR_x-QW_{xx} and LXRO-QR00

Bin Code	Minimum Forward Voltage (V)	Maximum Forward Voltage (V)
F	2.63	2.75
G	2.75	2.88
H	2.88	3.00

About Lumileds

Lumileds is the light engine leader, delivering innovation, quality, and reliability.

For 100 years, Lumileds commitment to innovation has helped customers pioneer breakthrough products in the automotive, consumer and illumination markets.

Lumileds is shaping the future of light with our LEDs and automotive lamps, and helping our customers illuminate how people see the world around them.

To learn more about our portfolio of light engines visit www.lumileds.com.



©2015 Lumileds Holding B.V. All rights reserved.
LUXEON is a registered trademark of the Lumileds Holding B.V.
in the United States and other countries.

www.lumileds.com

Neither Lumileds Holding B.V. nor its affiliates shall be liable for any kind of loss of data or any other damages, direct, indirect or consequential, resulting from the use of the provided information and data. Although Lumileds Holding B.V. and/or its affiliates have attempted to provide the most accurate information and data, the materials and services information and data are provided "as is," and neither Lumileds Holding B.V. nor its affiliates warrants or guarantees the contents and correctness of the provided information and data. Lumileds Holding B.V. and its affiliates reserve the right to make changes without notice. You as user agree to this disclaimer and user agreement with the download or use of the provided materials, information and data.