



ENGLISH

## Datasheet

# Stainless Steel Manual Ball Valve

RS Stock number [764-4234](#)



### Features:

Investment casting

Blow-out proof stem

Locking device

ISO 5211 Mounting pad

TA-Luft approved (option)

Length conform to DIN 3202/4-M3-2013SM3 (option)

Thread type: ASME B1.20.1 (NPT) DIN2999 and BS21 ISO7/1 and EN10226

3-piece design allows in-situ maintenance and servicing

Lockable Full Bore valves with thermally insulating lever sleeve

Incorporates ISO-5211 mounting flange for suitable actuator

Blow Out Proof Stem with Adjustable Stem packing

Seal, Thrust Washer, Stem Pack Material - P.T.F.E

Seat Material - P.T.F.E (15% Reinforced Glassfibre)

**Specifications:**

- Attachment Type: Threaded
- Ball Material: Stainless Steel
- Body Material: Stainless Steel
- Handle Colour: Blue
- Handle Material: Stainless Steel
- Maximum Operating Temperature: 230 °C
- Maximum Working Pressure: 1000 psi
- Safe for Use With: Gas, Oil and Water
- Thread Size: ½ in
- Threaded Connection: ½ in

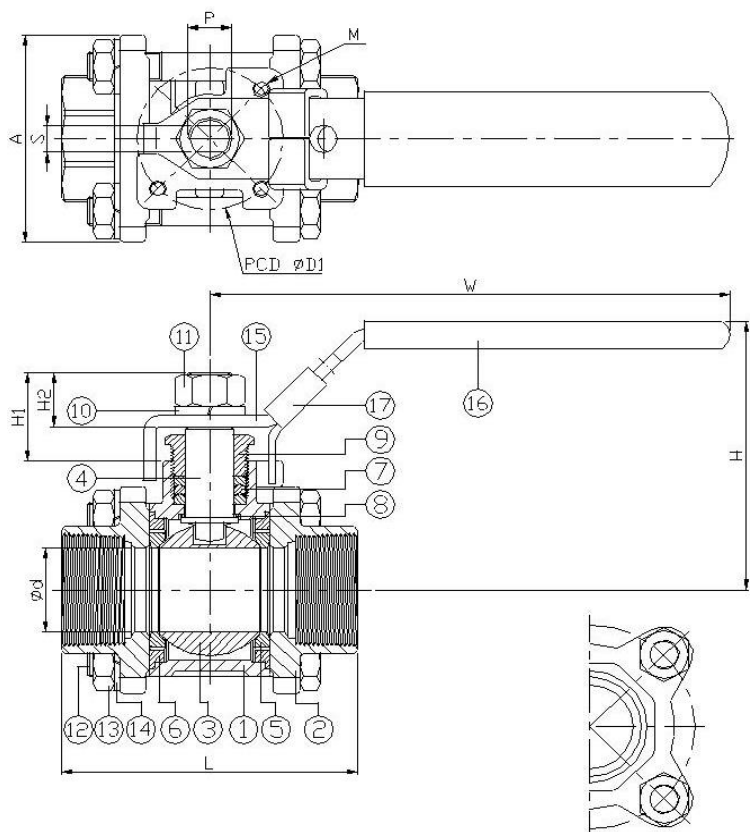

Figure 1



ITEM	PARTS	MATERIAL
1	BODY	ASTM A351-CF8M
2	CAP	ASTM A351-CF8M
3	BALL	ASTM A351-CF8M
4	STEM	ASTM A276-316
5	SEAT	PTFE / RTFE
6	SEAL	PTFE
7	PACKING	PTFE
8	THRUST WASHER	PTFE
9	GLAND NUT	AISI 304
10	SPRING WASHER	AISI 304
11	STEM NUT	AISI 304
12	BOLT	AISI 304
13	NUT	AISI 304
14	SPRING WASHER	AISI 304
15	HANDLE	STAINLESS STEEL
16	HANDLE SLEEVE	PVC
17	LOCKING DEVICE	STAINLESS STEEL

**Measurements:**

DN	d	L	H	H1	H2	W	S	A	D1	M
15	15	65	62	19.4	13.5	100	5	46.7	36	M5

P	ISO 5211	Torque (N-M)	Weight (kg)
3/8" – 24 UNF	F03	7.5	0.5

The measurements in the above tables are given in mm unless otherwise stated. The data corresponds to the lettering given in Figure 1.