

FEATURES

- 1.3 pF off capacitance
- 3.5 pF on capacitance
- 1 pC charge injection
- 33 V supply range
- 120 Ω on resistance
- Fully specified at +12 V, ± 15 V
- No V_L supply required
- 3 V logic-compatible inputs
- Rail-to-rail operation
- 16-lead TSSOP and 12-lead LFCSP packages
- Typical power consumption: <0.03 μ W

APPLICATIONS

- Automatic test equipment
- Data acquisition systems
- Battery-powered systems
- Sample-and-hold systems
- Audio/video signal routing
- Communication systems

GENERAL DESCRIPTION

The ADG1236 is a monolithic CMOS device containing two independently selectable SPDT switches. It is designed on an *i*CMOS process. *i*CMOS (industrial CMOS) is a modular manufacturing process combining high voltage complementary metal-oxide semiconductor (CMOS) and bipolar technologies. It enables the development of a wide range of high performance analog ICs capable of 33 V operation in a footprint that no previous generation of high voltage parts has been able to achieve. Unlike analog ICs using conventional CMOS processes, *i*CMOS components can tolerate high supply voltages while providing increased performance, dramatically lower power consumption, and reduced package size.

The ultralow capacitance and charge injection of the part make it an ideal solution for data acquisition and sample-and-hold applications, where low glitch and fast settling are required. Fast switching speed coupled with high signal bandwidth makes the part suitable for video signal switching. *i*CMOS construction ensures ultralow power dissipation, making the part ideally suited for portable and battery-powered instruments.

FUNCTIONAL BLOCK DIAGRAM

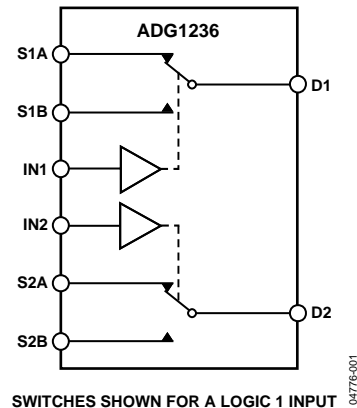

Figure 1.

Each switch conducts equally well in both directions when on and has an input signal range that extends to the supplies. In the off condition, signal levels up to the supplies are blocked. Both switches exhibit break-before-make switching action for use in multiplexer applications.

PRODUCT HIGHLIGHTS

1. 1.3 pF off capacitance (± 15 V supply).
2. 1 pC charge injection.
3. 3 V logic-compatible digital inputs: $V_{IH} = 2.0$ V, $V_{IL} = 0.8$ V.
4. No V_L logic power supply required.
5. Ultralow power dissipation: <0.03 μ W.
6. 16-lead TSSOP and 12-lead 3 mm \times 3 mm LFCSP packages.

Rev. 0

Information furnished by Analog Devices is believed to be accurate and reliable. However, no responsibility is assumed by Analog Devices for its use, nor for any infringements of patents or other rights of third parties that may result from its use. Specifications subject to change without notice. No license is granted by implication or otherwise under any patent or patent rights of Analog Devices. Trademarks and registered trademarks are the property of their respective owners.

TABLE OF CONTENTS

Features	1	Absolute Maximum Ratings	6
Applications.....	1	Truth Table for Switches.....	6
Functional Block Diagram	1	ESD Caution.....	6
General Description	1	Pin Configurations and Function Descriptions	7
Product Highlights	1	Terminology	8
Revision History	2	Typical Performance Characteristics	9
Specifications.....	3	Test Circuits.....	12
Dual Supply	3	Outline Dimensions	14
Single Supply	5	Ordering Guide	14

REVISION HISTORY

9/05—Revision 0: Initial Version

SPECIFICATIONS

DUAL SUPPLY

$V_{DD} = 15\text{ V} \pm 10\%$, $V_{SS} = -15\text{ V} \pm 10\%$, $GND = 0\text{ V}$, unless otherwise noted.

Table 1.

Parameters	Y Version ¹			Unit	Test Conditions/Comments ¹
	25°C	-40°C to +85°C	-40°C to +125°C		
ANALOG SWITCH					
Analog Signal Range			V_{DD} to V_{SS}	V	
On Resistance (R_{ON})	120			Ω typ	$V_S = \pm 10\text{ V}$, $I_S = -1\text{ mA}$; Figure 20
	190	230	260	Ω max	$V_{DD} = +13.5\text{ V}$, $V_{SS} = -13.5\text{ V}$
On Resistance Match Between Channels (ΔR_{ON})	3.5			Ω typ	$V_S = \pm 10\text{ V}$, $I_S = -1\text{ mA}$
On Resistance Flatness ($R_{FLAT(ON)}$)	6	10	12	Ω max	
	20			Ω typ	$V_S = -5\text{ V}, 0\text{ V}, +5\text{ V}$; $I_S = -1\text{ mA}$
	57	72	79	Ω max	
LEAKAGE CURRENTS					
Source Off Leakage, I_S (Off)	± 0.02			nA typ	$V_{DD} = +16.5\text{ V}$, $V_{SS} = -16.5\text{ V}$
	± 0.1	± 0.6	± 1	nA max	$V_S = \pm 10\text{ V}$, $V_D = \mp 10\text{ V}$; Figure 21
Drain Off Leakage, I_D (Off)	± 0.02			nA typ	
	± 0.1	± 0.6	± 1	nA max	$V_S = \pm 10\text{ V}$, $V_D = \mp 10\text{ V}$; Figure 21
Channel On Leakage, I_D , I_S (On)	± 0.02			nA typ	
	± 0.2	± 0.6	± 1	nA max	$V_S = V_D = \pm 10\text{ V}$; Figure 22
DIGITAL INPUTS					
Input High Voltage, V_{INH}			2.0	V min	
Input Low Voltage, V_{INL}			0.8	V max	
Input Current, I_{INL} or I_{INH}	0.005			μA typ	$V_{IN} = V_{INL}$ or V_{INH}
			± 0.1	μA max	
Digital Input Capacitance, C_{IN}	2			pF typ	
DYNAMIC CHARACTERISTICS²					
Transition Time, $t_{TRANS AOFF BON}$	125			ns typ	$R_L = 300\ \Omega$, $C_L = 35\text{ pF}$
	150		200	ns max	$V_S = 10\text{ V}$; Figure 23
Transition Time, $t_{TRANS BOFF AON}$	70			ns typ	$R_L = 300\ \Omega$, $C_L = 35\text{ pF}$
	90		115	ns max	$V_S = 10\text{ V}$; Figure 23
Break-Before-Make Time Delay, t_D	25			ns typ	$R_L = 300\ \Omega$, $C_L = 35\text{ pF}$
			10	ns min	$V_{S1} = V_{S2} = 10\text{ V}$; Figure 24
Charge Injection	-1			pC typ	$V_S = 0\text{ V}$, $R_S = 0\ \Omega$, $C_L = 1\text{ nF}$; Figure 25
Off Isolation	80			dB typ	$R_L = 50\ \Omega$, $C_L = 5\text{ pF}$, $f = 1\text{ MHz}$; Figure 26
Channel-to-Channel Crosstalk	85			dB typ	$R_L = 50\ \Omega$, $C_L = 5\text{ pF}$, $f = 1\text{ MHz}$; Figure 27
Total Harmonic Distortion + Noise	0.15			% typ	$R_L = 10\text{ k}\Omega$, 5 V rms , $f = 20\text{ Hz to } 20\text{ kHz}$
-3 dB Bandwidth	1000			MHz typ	$R_L = 50\ \Omega$, $C_L = 5\text{ pF}$; Figure 28
C_S (Off)	1.3			pF typ	$f = 1\text{ MHz}$; $V_S = 0\text{ V}$
	1.6			pF max	$f = 1\text{ MHz}$; $V_S = 0\text{ V}$
C_D , C_S (On)	3.5			pF typ	$f = 1\text{ MHz}$; $V_S = 0\text{ V}$
	4.3			pF max	$f = 1\text{ MHz}$; $V_S = 0\text{ V}$

ADG1236

Parameters	Y Version ¹			Unit	Test Conditions/Comments ¹
	25°C	-40°C to +85°C	-40°C to +125°C		
POWER REQUIREMENTS					$V_{DD} = +16.5\text{ V}$, $V_{SS} = -16.5\text{ V}$
I_{DD}	0.001		1.0	$\mu\text{A typ}$ $\mu\text{A max}$	Digital inputs = 0 V or V_{DD}
I_{DD}	170		230	$\mu\text{A typ}$ $\mu\text{A max}$	Digital inputs = 5 V
I_{SS}	0.001		1.0	$\mu\text{A typ}$ $\mu\text{A max}$	Digital inputs = 0 V or V_{DD}
I_{SS}	0.001		1.0	$\mu\text{A typ}$ $\mu\text{A max}$	Digital inputs = 5 V

¹ Temperature range for Y version is -40°C to +125°C.

² Guaranteed by design; not subject to production test.

SINGLE SUPPLY

$V_{DD} = 12\text{ V} \pm 10\%$, $V_{SS} = 0\text{ V}$, $GND = 0\text{ V}$, unless otherwise noted.

Table 2.

Parameters	Y Version ¹			Unit	Test Conditions/Comments
	25°C	-40°C to +85°C	-40°C to +125°C		
ANALOG SWITCH					
Analog Signal Range			0 V to V_{DD}	V	
On Resistance (R_{ON})	300			Ω typ	$V_S = 0\text{ V to }10\text{ V}$, $I_S = -1\text{ mA}$; Figure 20
	475	567	625	Ω max	$V_{DD} = 10.8\text{ V}$, $V_{SS} = 0\text{ V}$
On Resistance Match Between Channels (ΔR_{ON})	4.5			Ω typ	$V_S = 0\text{ V to }10\text{ V}$, $I_S = -1\text{ mA}$
	16	26	27	Ω max	
On Resistance Flatness ($R_{FLAT(ON)}$)	60			Ω typ	$V_S = 3\text{ V, }6\text{ V, }9\text{ V}$, $I_S = -1\text{ mA}$
LEAKAGE CURRENTS					
Source Off Leakage, I_S (Off)	± 0.02			nA typ	$V_{DD} = 13.2\text{ V}$
	± 0.1	± 0.6	± 1	nA max	$V_S = 1\text{ V}/10\text{ V}$, $V_D = 10\text{ V}/1\text{ V}$; Figure 21
Drain Off Leakage, I_D (Off)	± 0.02			nA typ	$V_S = 1\text{ V}/10\text{ V}$, $V_D = 10\text{ V}/1\text{ V}$; Figure 21
	± 0.1	± 0.6	± 1	nA max	
Channel On Leakage, I_D , I_S (On)	± 0.02			nA typ	$V_S = V_D = 1\text{ V or }10\text{ V}$, Figure 22
	± 0.2	± 0.6	± 1	nA max	
DIGITAL INPUTS					
Input High Voltage, V_{INH}			2.0	V min	
Input Low Voltage, V_{INL}			0.8	V max	
Input Current, I_{INL} or I_{INH}	0.001			μA typ	$V_{IN} = V_{INL}$ or V_{INH}
			± 0.1	μA max	
Digital Input Capacitance, C_{IN}	3			pF typ	
DYNAMIC CHARACTERISTICS²					
Transition Time, $t_{TRANS\ BOFF\ AON}$	105			ns typ	$R_L = 300\ \Omega$, $C_L = 35\text{ pF}$
	140		175	ns max	$V_S = 8\text{ V}$; Figure 23
Transition Time, $t_{TRANS\ AOFF\ BON}$	155			ns typ	$R_L = 300\ \Omega$, $C_L = 35\text{ pF}$
	190		255	ns max	$V_S = 8\text{ V}$; Figure 23
Break-Before-Make Time Delay, t_D	50			ns typ	$R_L = 300\ \Omega$, $C_L = 35\text{ pF}$
			10	ns min	$V_{S1} = V_{S2} = 8\text{ V}$; Figure 24
Charge Injection	-0.8			pC typ	$V_S = 6\text{ V}$, $R_S = 0\ \Omega$, $C_L = 1\text{ nF}$; Figure 25
Off Isolation	75			dB typ	$R_L = 50\ \Omega$, $C_L = 5\text{ pF}$, $f = 1\text{ MHz}$; Figure 26;
Channel-to-Channel Crosstalk	85			dB typ	$R_L = 50\ \Omega$, $C_L = 5\text{ pF}$, $f = 1\text{ MHz}$; Figure 27
-3 dB Bandwidth	800			MHz typ	$R_L = 50\ \Omega$, $C_L = 5\text{ pF}$; Figure 28
C_S (Off)	1.6			pF typ	$f = 1\text{ MHz}$; $V_S = 6\text{ V}$
	1.9			pF max	$f = 1\text{ MHz}$; $V_S = 6\text{ V}$
C_D , C_S (On)	4			pF typ	$f = 1\text{ MHz}$; $V_S = 6\text{ V}$
	4.9			pF max	$f = 1\text{ MHz}$; $V_S = 6\text{ V}$
POWER REQUIREMENTS					
I_{DD}	0.001			μA typ	$V_{DD} = 13.2\text{ V}$
			1.0	μA max	Digital inputs = 0 V or V_{DD}
I_{DD}	170			μA typ	Digital inputs = 5 V
			230	μA max	

¹ Temperature range for Y version is -40°C to +125°C.

² Guaranteed by design; not subject to production test.

ABSOLUTE MAXIMUM RATINGS

T_A = 25°C, unless otherwise noted.

Table 3.

Parameter	Rating
V _{DD} to V _{SS}	35 V
V _{DD} to GND	−0.3 V to +25 V
V _{SS} to GND	+0.3 V to −25 V
Analog Inputs ¹	V _{SS} − 0.3 V to V _{DD} + 0.3 V or 30 mA, whichever occurs first
Digital Inputs ¹	GND − 0.3 V to V _{DD} + 0.3 V or 30 mA, whichever occurs first
Peak Current, S or D	100 mA (pulsed at 1 ms, 10% duty cycle max)
Continuous Current per Channel, S or D	25 mA
Operating Temperature Range Automotive (Y Version)	−40°C to +125°C
Storage Temperature Range	−65°C to +150°C
Junction Temperature	150°C
16-Lead TSSOP, θ _{JA} Thermal Impedance	112°C/W
12-Lead LFCSP, θ _{JA} Thermal Impedance	80°C/W
Reflow Soldering Peak Temperature, Pb Free	260°C

¹ Over voltages at IN, S, or D are clamped by internal diodes. Current should be limited to the maximum ratings given.

ESD CAUTION

ESD (electrostatic discharge) sensitive device. Electrostatic charges as high as 4000V readily accumulate on the human body and test equipment and can discharge without detection. Although this product features proprietary ESD protection circuitry, permanent damage may occur on devices subjected to high energy electrostatic discharges. Therefore, proper ESD precautions are recommended to avoid performance degradation or loss of functionality.



Stresses above those listed under Absolute Maximum Ratings may cause permanent damage to the device. This is a stress rating only; functional operation of the device at these or any other conditions above those indicated in the operational section of this specification is not implied. Exposure to absolute maximum rating conditions for extended periods may affect device reliability.

TRUTH TABLE FOR SWITCHES

Table 4.

IN	Switch A	Switch B
0	Off	On
1	On	Off

PIN CONFIGURATIONS AND FUNCTION DESCRIPTIONS

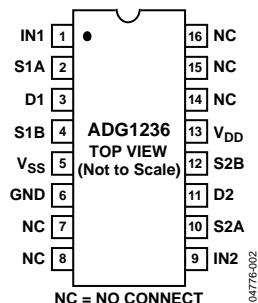

Figure 2. TSSOP Pin Configuration

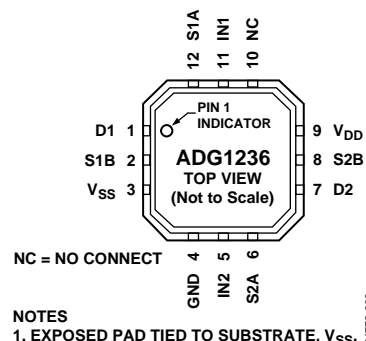

Figure 3. LFCSP Pin Configuration

Table 5. Pin Function Descriptions

Pin No.		Mnemonic	Description
TSSOP	LFCSP		
1	11	IN1	Logic Control Input.
2	12	S1A	Source Terminal. Can be an input or output.
3	1	D1	Drain Terminal. Can be an input or output.
4	2	S1B	Source Terminal. Can be an input or output.
5	3	V _{SS}	Most Negative Power Supply Potential.
6	4	GND	Ground (0 V) Reference.
7, 8, 14 to 16	10	NC	No Connect.
9	5	IN2	Logic Control Input.
10	6	S2A	Source Terminal. Can be an input or output.
11	7	D2	Drain Terminal. Can be an input or output.
12	8	S2B	Source Terminal. Can be an input or output.
13	9	V _{DD}	Most Positive Power Supply Potential.

TERMINOLOGY

I_{DD}

The positive supply current.

I_{SS}

The negative supply current.

V_D (V_S)

The analog voltage on Terminals D and S.

R_{ON}

The ohmic resistance between D and S.

R_{FLAT(ON)}

Flatness is defined as the difference between the maximum and minimum value of on resistance as measured over the specified analog signal range.

I_S (Off)

The source leakage current with the switch off.

I_D (Off)

The drain leakage current with the switch off.

I_D, I_S (On)

The channel leakage current with the switch on.

V_{INL}

The maximum input voltage for Logic 0.

V_{INH}

The minimum input voltage for Logic 1.

I_{INL} (I_{INH})

The input current of the digital input.

C_S (Off)

The off switch source capacitance, measured with reference to ground.

C_D (Off)

The off switch drain capacitance, measured with reference to ground.

C_D, C_S (On)

The on switch capacitance, measured with reference to ground.

C_{IN}

The digital input capacitance.

t_{TRANS}

The delay time between the 50% and 90% points of the digital input and switch on condition when switching from one address state to another.

Charge Injection

A measure of the glitch impulse transferred from the digital input to the analog output during switching.

Off Isolation

A measure of unwanted signal coupling through an off switch.

Crosstalk

A measure of unwanted signal that is coupled through from one channel to another as a result of parasitic capacitance.

Bandwidth

The frequency at which the output is attenuated by 3 dB.

On Response

The frequency response of the on switch.

Insertion Loss

The loss due to the on resistance of the switch.

THD + N

The ratio of the harmonic amplitude plus noise of the signal to the fundamental.

TYPICAL PERFORMANCE CHARACTERISTICS

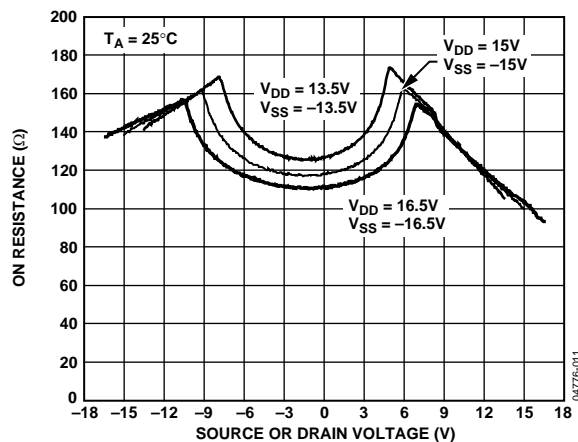

Figure 4. On Resistance as a Function of V_D (V_S) for Dual Supply

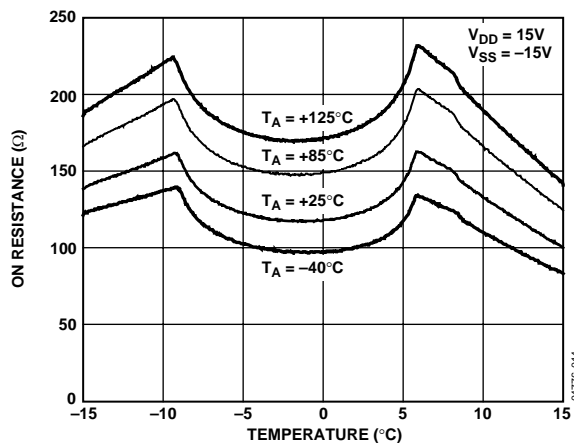

Figure 7. On Resistance as a Function of V_D (V_S) for Different Temperatures, Dual Supply

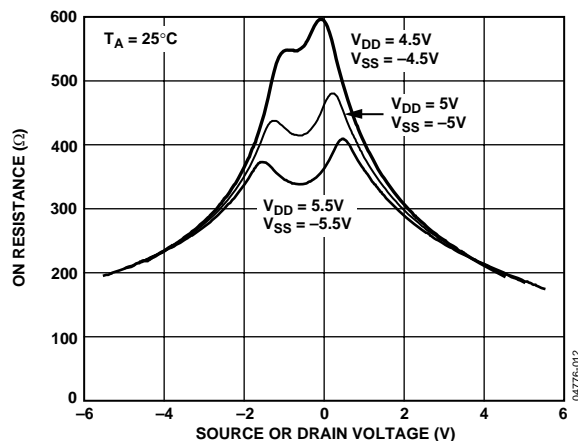

Figure 5. On Resistance as a Function of V_D (V_S) for Dual Supply

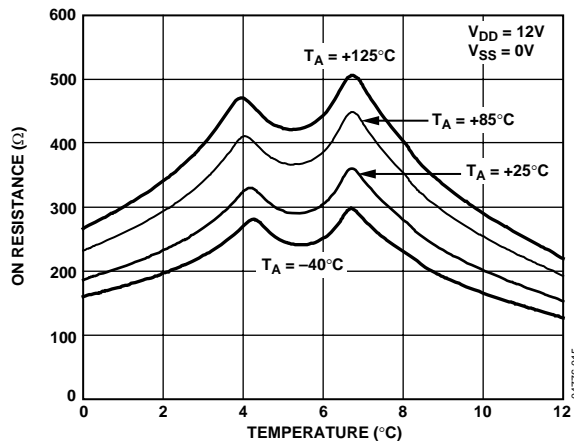

Figure 8. On Resistance as a Function of V_D (V_S) for Different Temperatures, Single Supply

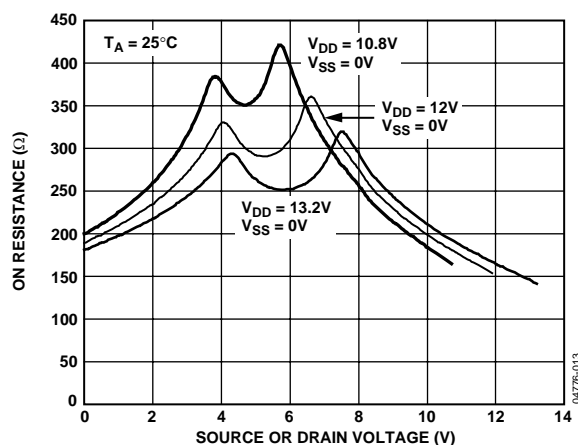

Figure 6. On Resistance as a Function of V_D (V_S) for Single Supply

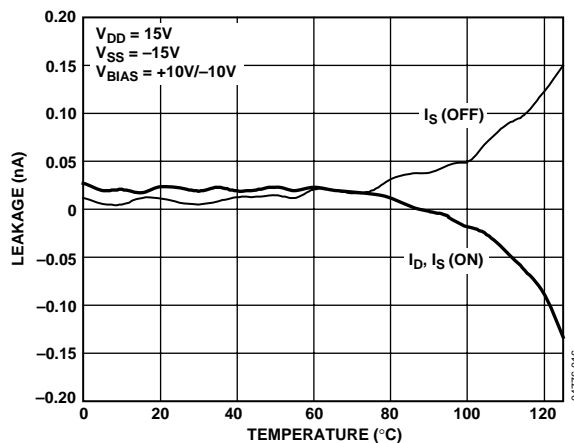

Figure 9. Leakage Currents as a Function of Temperature, Dual Supply

ADG1236

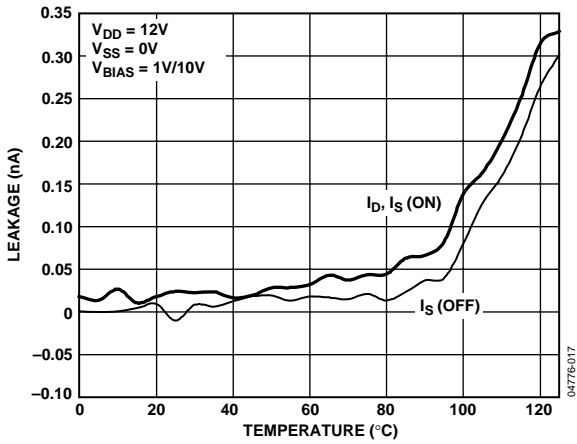

Figure 10. Leakage Currents as a Function of Temperature, Single Supply

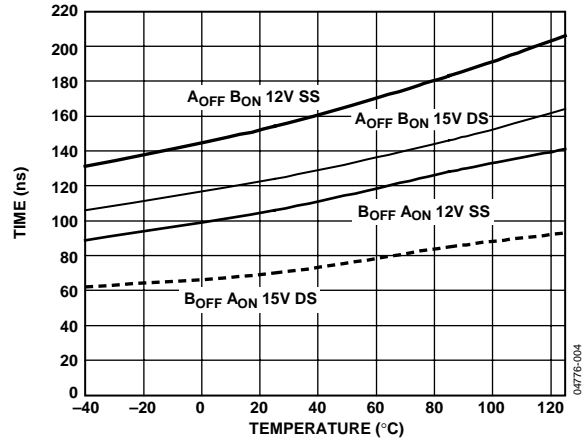

Figure 13. $t_{\text{TRANSITION}}$ Times vs. Temperature

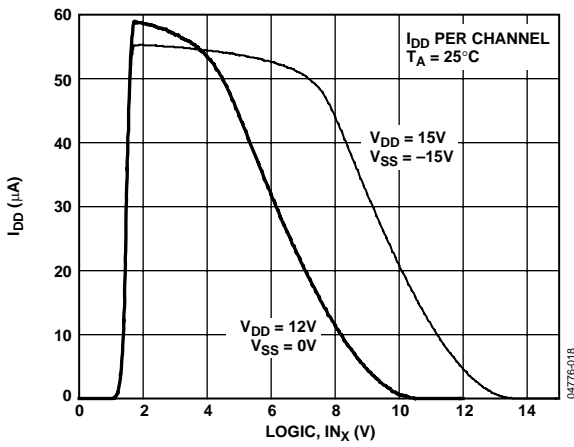

Figure 11. I_{DD} vs. Logic Level

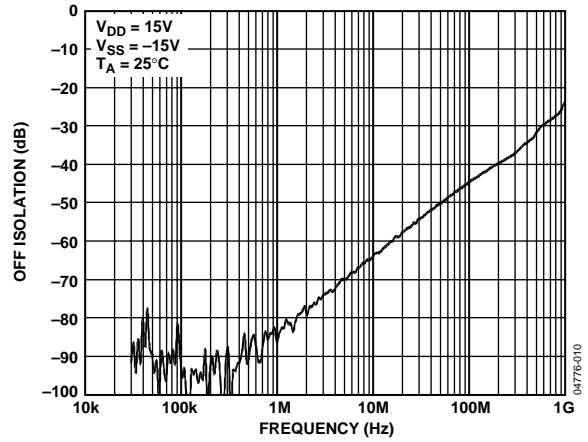

Figure 14. Off Isolation vs. Frequency

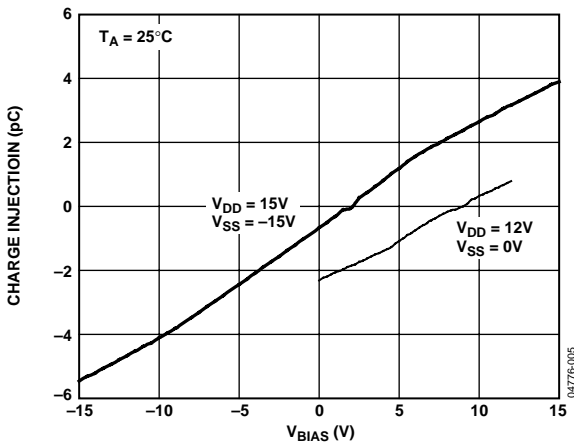

Figure 12. Charge Injection vs. Source Voltage

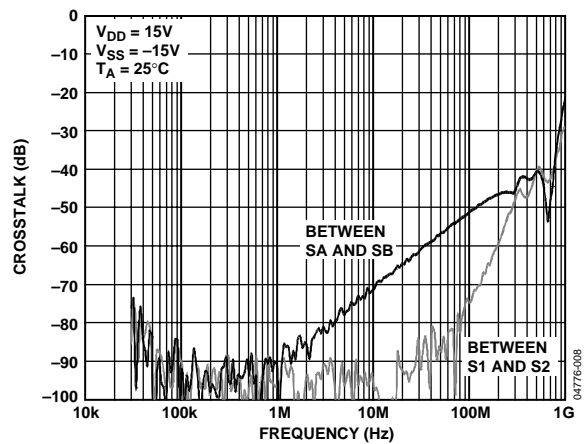

Figure 15. Crosstalk vs. Frequency

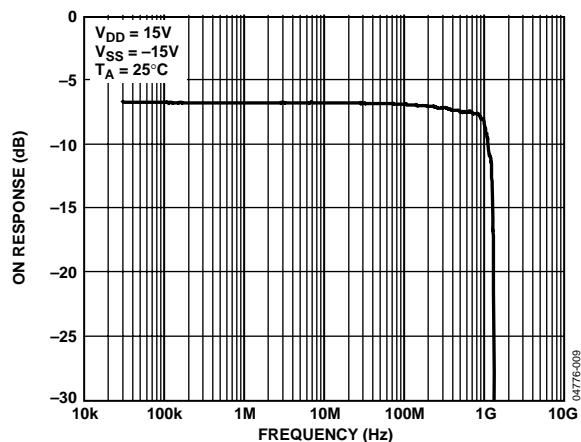

Figure 16. On Response vs. Frequency

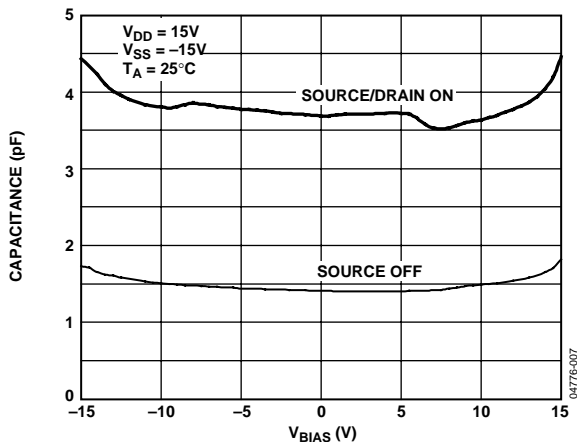

Figure 18. Capacitance vs. Source Voltage for Dual Supply

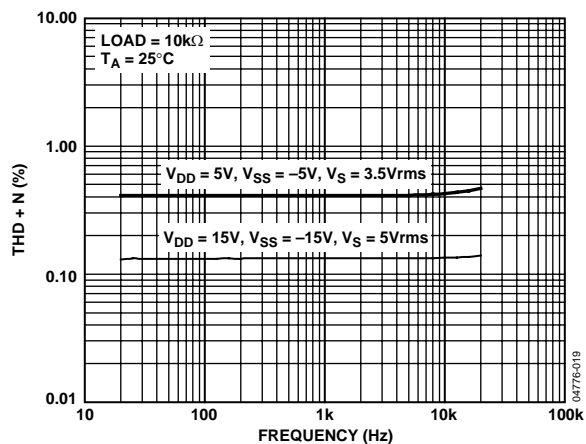

Figure 17. THD + N vs. Frequency

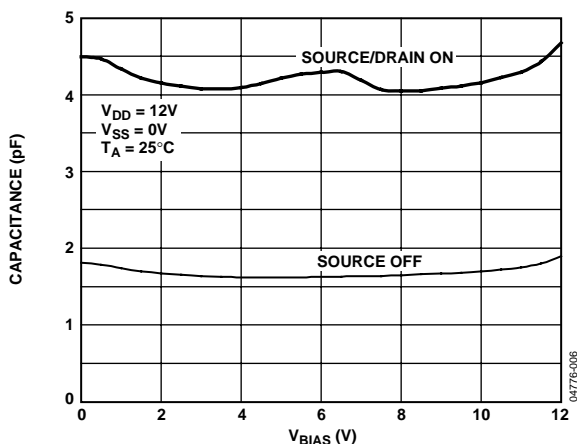

Figure 19. Capacitance vs. Source Voltage for Single Supply

TEST CIRCUITS

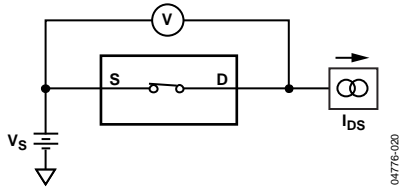

Figure 20. Test Circuit 1—On Resistance

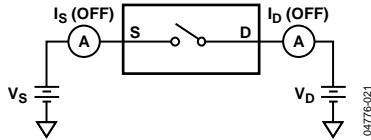

Figure 21. Test Circuit 2—Off Resistance

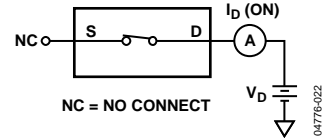

Figure 22. Test Circuit 3—On Leakage

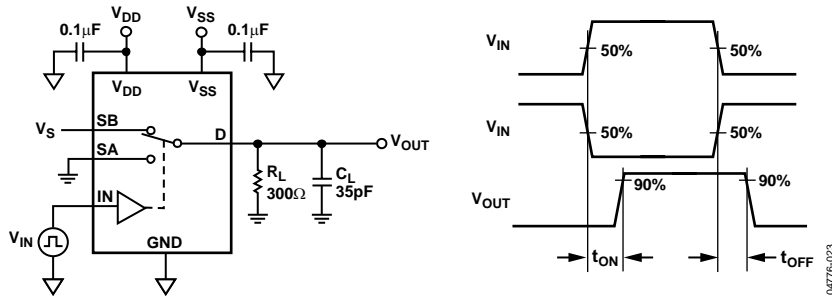

Figure 23. Test Circuit 4—Switching Times

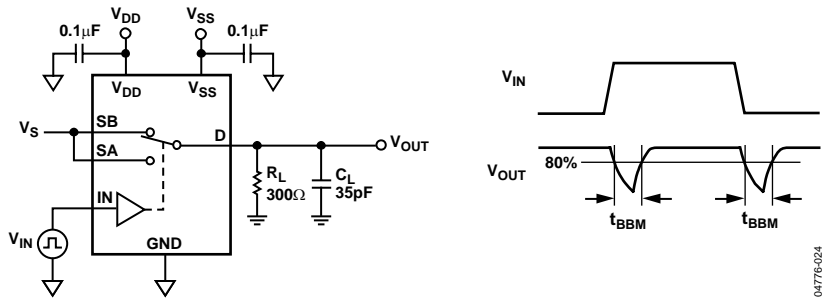

Figure 24. Test Circuit 5—Break-Before-Make Time Delay

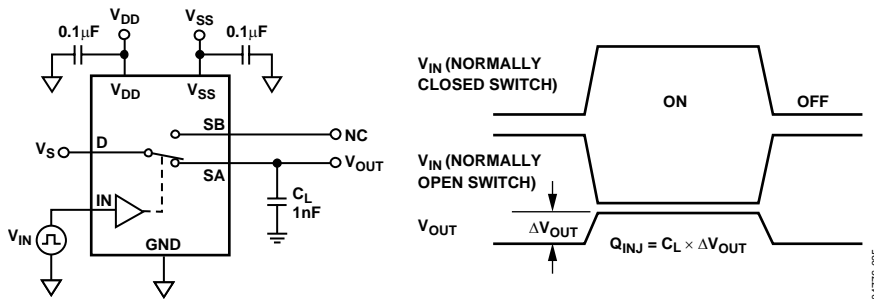

Figure 25. Test Circuit 6—Charge Injection

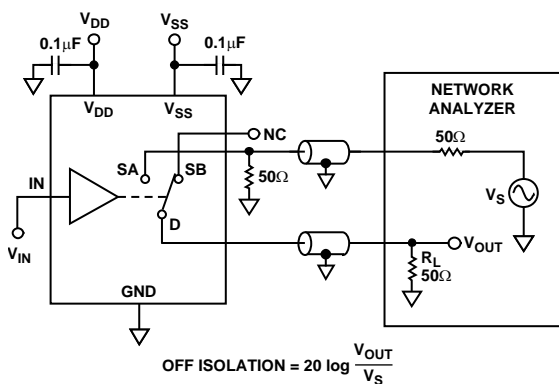

Figure 26. Test Circuit 7—Off Isolation

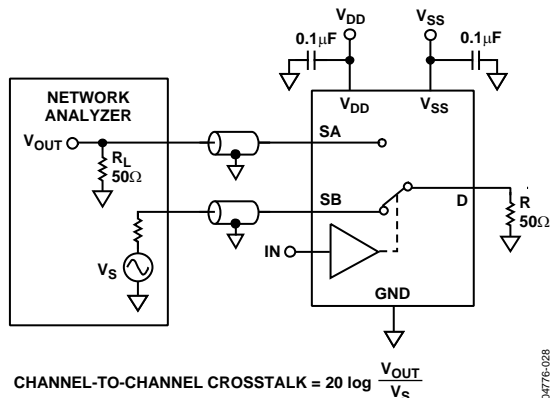

Figure 28. Test Circuit 9—Bandwidth

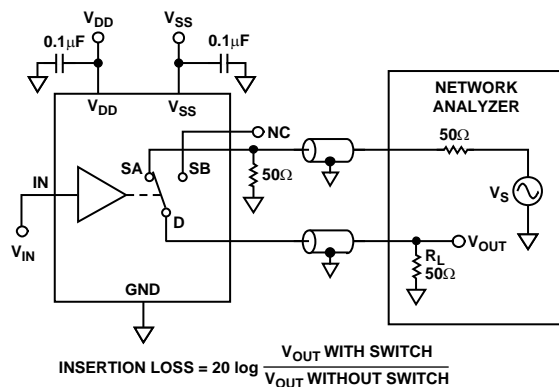

Figure 27. Test Circuit 8—Channel-to-Channel Crosstalk

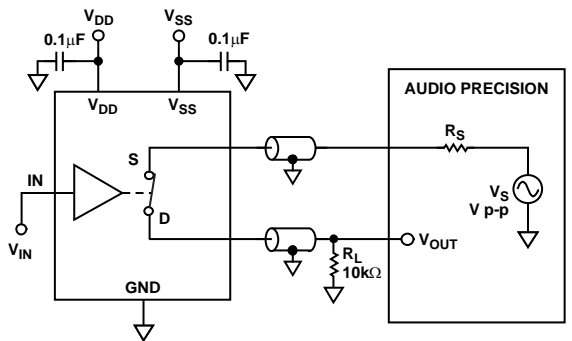

Figure 29. Test Circuit 10—THD + Noise

OUTLINE DIMENSIONS

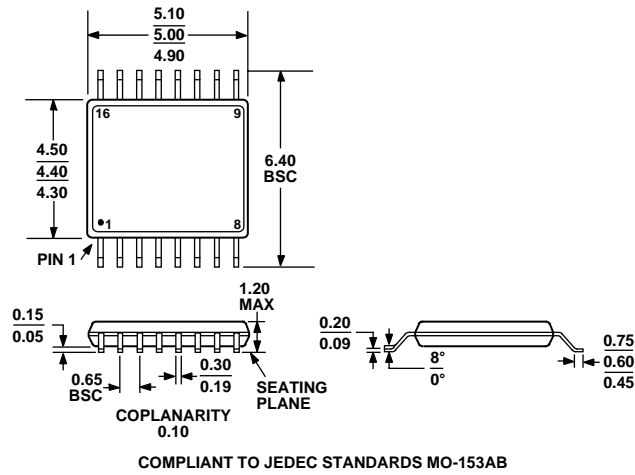

Figure 30. 16-Lead Thin Shrink Small Outline Package [TSSOP]
(RU-16)
Dimensions shown in millimeters

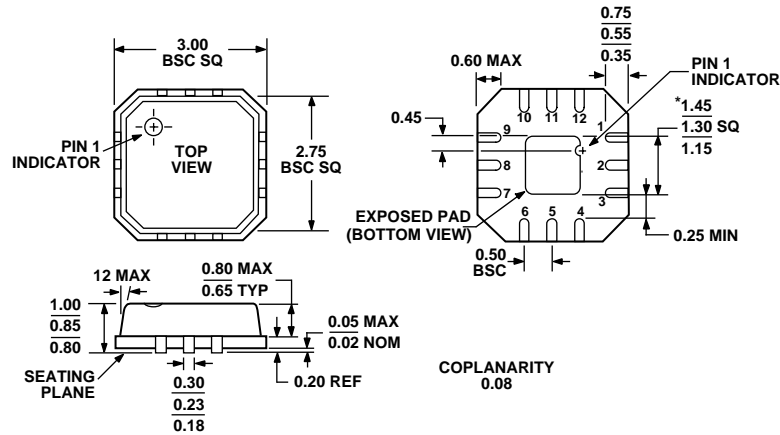

Figure 31. 12-Lead Lead Frame Chip Scale Package [LFCSP_VQ]
3 mm × 3 mm Body, Very Thin Quad
(CP-12-1)
Dimensions shown in millimeters

ORDERING GUIDE

Model	Temperature Range	Package Description	Package Option
ADG1236YRUZ ¹	-40°C to +125°C	16-Lead Thin Shrink Small Outline Package [TSSOP]	RU-16
ADG1236YRUZ-REEL ¹	-40°C to +125°C	16-Lead Thin Shrink Small Outline Package [TSSOP]	RU-16
ADG1236YRUZ-REEL7 ¹	-40°C to +125°C	16-Lead Thin Shrink Small Outline Package [TSSOP]	RU-16
ADG1236YCPZ-500RL7 ¹	-40°C to +125°C	12-Lead Lead Frame Chip Scale Package [LFCSP_VQ]	CP-12-1
ADG1236YCPZ-REEL7 ¹	-40°C to +125°C	12-Lead Lead Frame Chip Scale Package [LFCSP_VQ]	CP-12-1

¹ Z = Pb-free part.

NOTES

ADG1236

NOTES