

Series  
**57**  
*Indicator*

[www.eao.com](http://www.eao.com)



# Series 57

## Indicator

To achieve maximum safety in public transport, you need intuitive signage and a high level of reliability.

*EAO has expanded the successful Series 57 range with a new indicator.*

As a pioneer in illuminated pushbuttons and an expert in Human Machine Interfaces (HMIs), EAO continues to set new standards in public transportation. The Series 57 indicators impress with their intuitive visual feedback and high quality. Their modular construction enables them to be easily mounted as status indicators in exterior and interior doors, passenger compartments and toilets in public transportation, as well as public buildings.

The modern design and extra-large illuminated surface ensure that 'secret-til-lit' symbols or text are clearly visible even from far away. The Series 57 indicator is available with single or dual-colour illumination in red, yellow, green, blue and white. Flashing and dimming effects are also available.

It shares the same design as other Series 57 products, and therefore offers the same high IP69K front protection.

Mounting is quick and requires no tools, thus saving time and money. This makes the Series 57 indicators the perfect choice for all train, tram or bus manufacturers and operators.

### Typical applications

- Public transportation: rail, tram, bus
- Access control
- Emergency call and help points

### Materials

The materials used comply with the high EAO standards relating to quality, functional safety, service life and design. They are resistant to cleaning agents and are also highly resistant to UV radiation.

### Mechanical characteristics

- Cable, 2-wire with core-end sleeves for the standard single-colour version (wire cross section 0.5 mm<sup>2</sup>)
- Cable, 4-wire with core-end sleeves for the dual-colour version and for versions with light effect functions (wire cross section 0.5 mm<sup>2</sup>)
- Cable length: 200 mm; 1000 mm; 2000 mm (other lengths upon request)
- Resistant to impact shocks and vibrations
- Plug connectors upon request

### Electrical characteristics

- Single-colour: 20 LEDs, red, yellow, green, blue or white
- Dual-colour: 40 LEDs, red/yellow, red/green or blue/white
- Operating voltage:
  - 110 VDC ± 30 %
  - 24 VDC ± 30 %
- Current consumption: < 60 mA
- The illumination may vary slightly depending on the manufacturer of the LEDs

### Ambient conditions

Temperature

- Storage temperature –45 °C to +90 °C
- Operating temperature –40 °C to +85 °C

### Degree of protection

- IP69K front protection
- IP67 rear protection

### Symbols

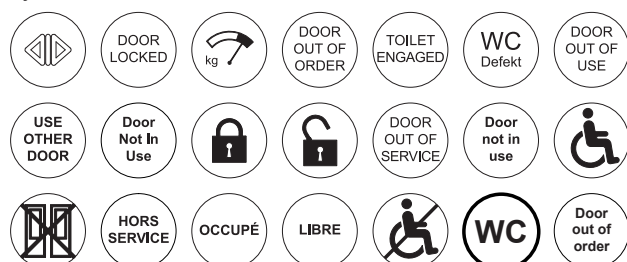

# Advantages.

- Extra-large illuminated surface
- Illumination in one or two colours
- Bright and homogenous illumination
- High IP69K front protection
- Optional flashing or dimming effects

## Colour of front bezel

- Plastic: Green RAL 6032, red RAL 3000, blue RAL 5015, yellow RAL 1023, grey RAL 7040, black RAL 9017
- Metal: Aluminium, natural anodized

## Standards and directives

- Declaration of Conformity
  - EN 50155
- Fire protection
  - EN 45545
- Cable in compliance with
  - DIN EN 50306-2; VDE 0260-306-2
  - DIN EN 50306-4; VDE 0260-306-4
  - NFF 63808/NFF 61030

## Mounting/replacement

The mounting dimensions of the Series 57 indicators are compliant with industry standards and are identical to those of other manufacturers – making it easy to upgrade straight to the Series 57 from other indicators.

## Dimensions

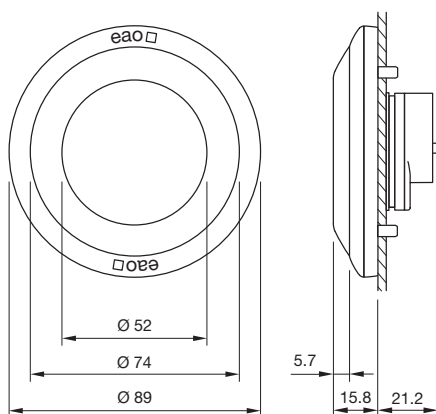

## Mounting cut-outs

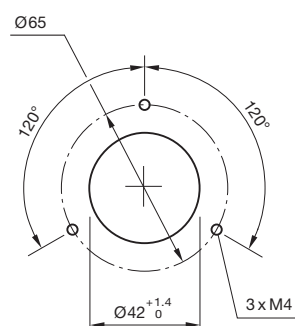

## Diagram single-colour, no software

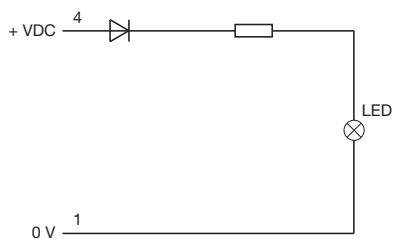

## Diagram, bi-colour, no software

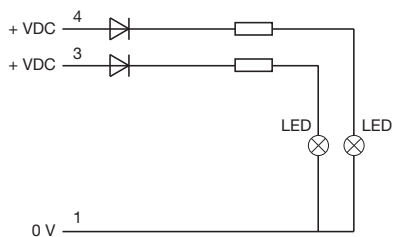

## Diagram, single-colour, with software

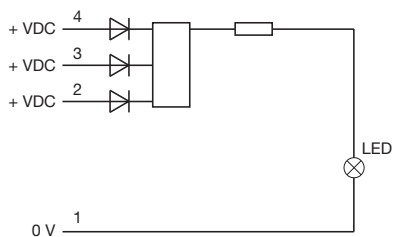

## Diagram, bi-colour, with software

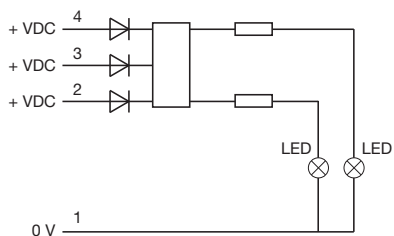

# EAO Contact.

## *Your centre of excellence.*

### Headquarters

EAO Holding AG  
Tannwaldstrasse 88  
CH-4600 Olten  
Telephone +41 62 286 91 11  
info@eao.com

### Manufacturing Companies

**Switzerland**  
EAO AG  
Tannwaldstrasse 88  
CH-4600 Olten  
Telephone +41 62 286 91 11  
info@eao.com

EAO Systems AG  
Tannwaldstrasse 88  
CH-4600 Olten  
Telephone +41 62 286 91 11  
sales.esy@eao.com

**China**  
EAO (Guangzhou) Ltd.  
RM 3A03, 3A/F, Block A,  
Guangzhou  
International Business  
Incubator Centre  
3 Ju Quan Lu,  
Guangzhou Science City  
CN-Guangzhou, PRC  
Telephone +86 20 322 903 90  
sales.ecn@eao.com

**Germany**  
EAO Automotive GmbH & Co. KG  
Richard-Wagner-Straße 3  
DE-08209 Auerbach/Vogtland  
Telephone +49 3744 8264 0  
sales.esa@eao.com

**North America**  
EAO Corporation  
One Parrott Drive  
Shelton,  
US-CT 06484  
Telephone +1 203 951 4600  
sales.eus@eao.com

### Sales Companies

**China**  
EAO (Guangzhou) Ltd.  
RM 3A03, 3A/F, Block A,  
Guangzhou  
International Business  
Incubator Centre  
3 Ju Quan Lu,  
Guangzhou Science City  
CN-Guangzhou, PRC  
Telephone +86 20 322 903 90  
sales.ecn@eao.com

**France**  
EAO France SAS  
5, rue Henri François  
FR-77330 Ozoir-la-Ferrière  
Telephone +33 1 64 43 37 37  
sales.efr@eao.com

**Germany, Austria,  
Poland, Czech Republic**  
EAO GmbH  
Langenberger Straße 570  
DE-45277 Essen  
Telephone +49 201 8587 0  
sales.ede@eao.com

**Hong Kong (Asia Pacific)**  
EAO (Far East) Ltd.  
Unit A1, 1/F, Block A  
Tin On Industrial Building  
777 Cheung Sha Wan Road  
Lai Chi Kok, Kln  
HK-Hong Kong  
Telephone +852 27 86 91 41  
sales.ehk@eao.com

**Italy**  
EAO Italia S.r.l.  
Piazza Monsignor L. Chiodi 3  
IT-24049 Verdello (Bergamo)  
Telephone +39 035 481 0189  
sales.eit@eao.com

**Japan**  
EAO Japan Co. Ltd.  
Net 1 Mita Bldg. 3F  
3-1-4 Mita Minato-ku  
JP-Tokyo 108-0073  
Telephone +81 3 5444 5411  
sales.esj@eao.com

**Netherlands, Belgium**  
EAO Benelux B.V.  
Kamerlingh Onnesweg 46  
Postbus 544  
NL-3300 AM Dordrecht  
Telephone +31 78 653 17 00  
sales.enl@eao.com

**North America**  
EAO Corporation  
One Parrott Drive  
Shelton,  
US-CT 06484  
Telephone +1 203 951 4600  
sales.eus@eao.com

**Sweden**  
EAO Svenska AB  
Slakthusgatan 9  
SE-121 62 Johanneshov  
Telephone +46 8 683 86 60  
sales.esw@eao.se

**Switzerland**  
EAO Schweiz AG  
Tannwaldstrasse 86  
CH-4600 Olten  
Telephone +41 62 286 95 00  
sales.ech@eao.com

**United Kingdom**  
EAO Ltd.  
Highland House  
Albert Drive  
Burgess Hill,  
GB-West Sussex RH15 9TN  
Telephone +44 1444 236 000  
sales.euk@eao.com