

Data Sheet

Monolithic Ceramic Capacitors

GRM32ER71H475KA88□ (1210, X7R, 4.7μF, 50Vdc)

□: packaging code

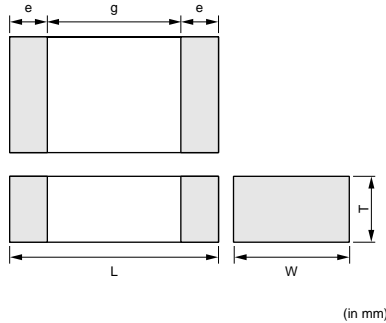

■ Dimensions

Length L	3.20mm±0.30mm
Width W	2.50mm±0.20mm
Thickness T	2.50mm±0.20mm
Electrode e (min.)	0.30mm
Electrode Gap g (min.)	1.00mm

■ Rated Value

TC Code	R7
TC Code (Standard)	X7R (EIA)
Capacitance Change	±15%
Capacitance	4.7μF±10%
Rated Voltage	50Vdc

■ Packaging

Code	Packaging	Minimum Quantity
L	180mm Plastic Tape	1000
K	330mm Plastic Tape	4000
B	Bulk(Bag)	1000

■ Specifications

Please refer to 'Specification' PDF file.

- This data sheet is applied for CHIP MONOLITHIC CERAMIC CAPACITOR used for General Electronics equipment for your design.

<Notice>

- Solderability of Tin plating termination chip might be deteriorated when low temperature soldering profile where peak solder temperature is below the Tin melting point is used. Please confirm the solderability of Tin plating termination chip before use.

⚠ Note:

- Export Control
 〈For customers outside Japan〉
 Murata products should not be used or sold for use in the development, production, stockpiling or utilization of any conventional weapons or mass-destructive weapons (nuclear weapons, chemical or biological weapons, or missiles), or any other weapons.
 〈For customers in Japan〉
 For products which are controlled items subject to the "Foreign Exchange and Foreign Trade Law" of Japan, the export license specified by the law is required for export.
- Please contact our sales representatives or product engineers before using the products in this data sheet for the applications listed below, which require especially high reliability for the prevention of defects which might directly damage to a third party's life, body or property, or when one of our products is intended for use in applications other than those specified in this data sheet.

① Aircraft equipment	② Aerospace equipment
③ Undersea equipment	④ Power plant equipment
⑤ Medical equipment	⑥ Transportation equipment (vehicles, trains, ships, etc.)
⑦ Traffic signal equipment	⑧ Disaster prevention / crime prevention equipment
⑨ Data-processing equipment	⑩ Application of similar complexity and/or reliability requirements to the applications listed in the above
- They are subject to change or our products in it may be discontinued without advance notice. Please check with our sales representatives or product engineers before ordering. If there are any questions, please contact our sales representatives or product engineers.
- This data sheet has only typical specifications because there is no space for detailed specifications. Therefore, please approve our product specifications or transact the approval sheet for product specifications before ordering. Especially, please read rating and ⚠CAUTION (for storage, operating, rating, soldering, mounting and handling) in them to prevent smoking and/or burning, etc.
- You are able to read a detailed specification in the website of Search Engine (<http://search.murata.co.jp/>) or catalog library (<http://www.murata.com/catalog/>) before to require our product specification or to transact the approval sheet for product specification.
- Please note that unless otherwise specified, we shall assume no responsibility whatsoever for any conflict or dispute that may occur in connection with the effect of our and/or a third party's intellectual property rights and other related rights in consideration of your use of our products and/or information described or contained in our data sheets. In this connection, no representation shall be made to the effect that any third parties are authorized to use the right mentioned above under licenses without our consent.
- No ozone depleting substances (ODS) under the Montreal Protocol are used in our manufacturing process.

■ Packaging Code

Packaging Type	Tape Carrier Packaging	Bulk Case Packaging	Bulk Packaging	
			Bulk Packaging in a Bag	Bulk Packaging in a Tray
Packaging Code	D, L, K, J, E, F	C	B	T

■ Minimum Quantity Guide

Part Number		Dimensions (mm)			Quantity (pcs.)					
					ø180mm reel		ø330mm reel		Bulk Case	Bulk Bag
		L	W	T	Paper Tape	Plastic Tape	Paper Tape	Plastic Tape		
Ultra Miniaturized	GRM02	0.4	0.2	0.2	20,000	-	-	-	-	-
	GRM03	0.6	0.3	0.3	15,000	-	50,000	-	-	1,000
For Flow/Reflow	GRM18	1.6	0.8	0.8	4,000	-	10,000	-	15,000	1,000
				0.6	4,000	-	10,000	-	10,000	1,000
	GRM21	2.0	1.25	0.85	4,000	-	10,000	-	-	1,000
				1.0	-	3,000	-	10,000	-	1,000
				1.25	-	3,000	-	10,000	5,000 ²⁾	1,000
	GRM31	3.2	1.6	0.6/0.85	4,000	-	10,000	-	-	1,000
				1.15	-	3,000	-	10,000	-	1,000
				1.6	-	2,000	-	6,000	-	1,000
For Reflow	GRM155	1.0	0.5	0.5	10,000	-	50,000	-	50,000	1,000
	GRM15X	1.0	0.5	0.25	10,000	-	50,000	-	-	1,000
	GRM32	3.2	2.5	1.15	-	3,000	-	10,000	-	1,000
				1.35	-	2,000	-	8,000	-	1,000
				1.8/1.6	-	1,000	-	4,000	-	1,000
				2.0	-	1,000	-	4,000	-	1,000
	GRM43	4.5	3.2	2.5	-	1,000	-	4,000	-	1,000
				1.15	-	1,000	-	5,000	-	1,000
				1.35/1.6 1.8/2.0	-	1,000	-	4,000	-	1,000
				2.5	-	500	-	2,000	-	1,000
	GRM55	5.7	5.0	2.8	-	500	-	1,500	-	1,000
				1.15	-	1,000	-	5,000	-	1,000
1.35/1.6 1.8/2.0				-	1,000	-	4,000	-	1,000	
2.5				-	500	-	2,000	-	500	
High Power Type	GJM03	0.6	0.3	0.3	15,000	-	50,000	-	-	1,000
	GJM15	1.0	0.5	0.5	10,000	-	50,000	-	50,000	1,000
High Frequency	GQM18	1.6	0.8	0.8	4,000	-	10,000	-	-	1,000
	GQM21	2.0	1.25	0.85	4,000	-	10,000	-	-	1,000
	ERB18	1.6	0.8	0.8	4,000	-	10,000	-	-	1,000
	ERB21	2.0	1.25	1.0/1.25	-	3,000	-	10,000	-	1,000
	ERB32	3.2	2.5	1.7	-	2,000	-	8,000	-	1,000
For Ultrasonic	GRM21	2.0	1.25	0.85	4,000	-	10,000	-	-	1,000
Micro Chip	GMA05	0.5	0.5	0.35	-	-	-	-	-	400 ¹⁾
	GMA08	0.8	0.8	0.5	-	-	-	-	-	400 ¹⁾
Array	GNM1M	1.37	1.0	0.6	4,000	-	10,000	-	-	1,000
				0.8	4,000	-	10,000	-	-	1,000
	GNM31	3.2	1.6	1.0	-	3,000	-	10,000	-	1,000
				0.6/0.85	4,000	-	10,000	-	-	1,000
Low ESL	LLL18	0.8	1.6	0.6	-	4,000	-	10,000	-	1,000
				0.6	-	4,000	-	10,000	-	1,000
	LLL21	1.25	2.0	0.85	-	3,000	-	10,000	-	1,000
				0.7	-	4,000	-	10,000	-	1,000
	LLL31	1.6	3.2	1.15	-	3,000	-	10,000	-	1,000
				0.5	-	4,000	-	10,000	-	1,000
	LLA18	1.6	0.8	0.5	-	4,000	-	10,000	-	1,000
				0.5	-	4,000	-	10,000	-	1,000
	LLA21	2.0	1.25	0.85	-	3,000	-	10,000	-	1,000
				0.5	-	4,000	-	10,000	-	1,000
	LLA31	3.2	1.6	0.85	-	3,000	-	10,000	-	1,000
				1.15	-	3,000	-	10,000	-	1,000
				0.5	-	4,000	-	10,000	-	1,000
LLM21	2.0	1.25	0.85	-	3,000	-	10,000	-	1,000	
			0.5	-	4,000	-	10,000	-	1,000	
LLM31	3.2	1.6	1.15	-	3,000	-	10,000	-	1,000	
			0.5	-	4,000	-	10,000	-	1,000	

1) Tray 2) 10µF, 1.0µF, 3.3/4.7µF of 6.3V R6 rated are not available by bulk case.

Continued from the preceding page.

■ Tape Carrier Packaging

(1) Dimensions of Reel

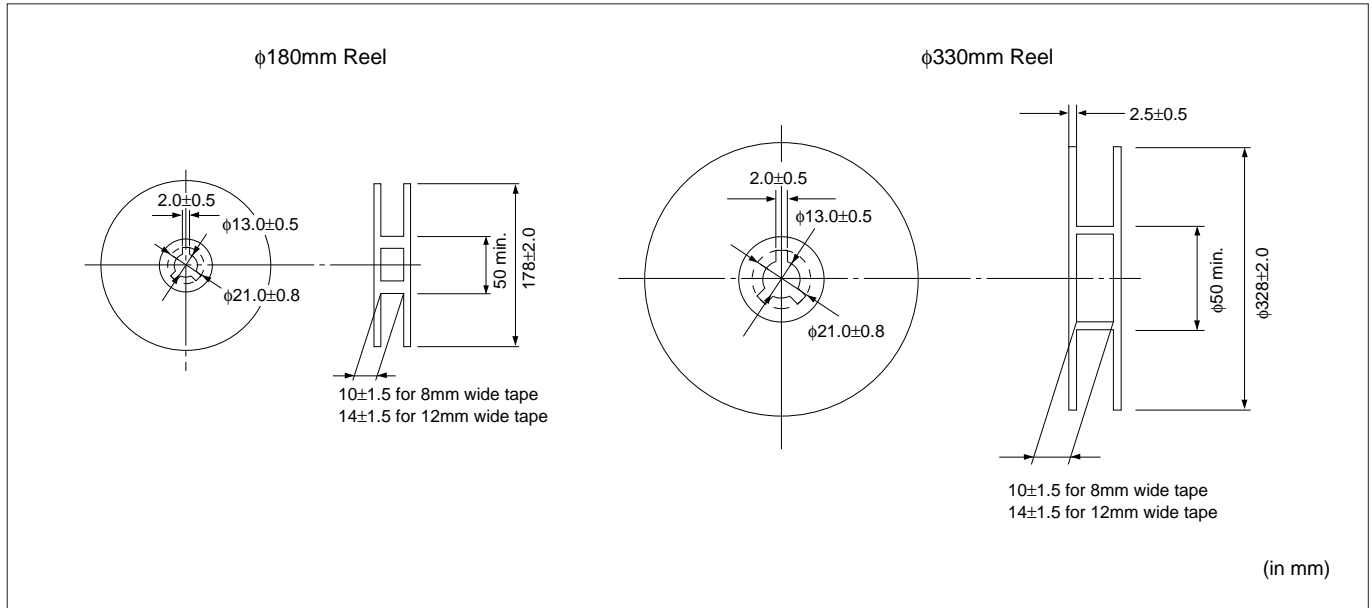

(2) Dimensions of Paper Tape

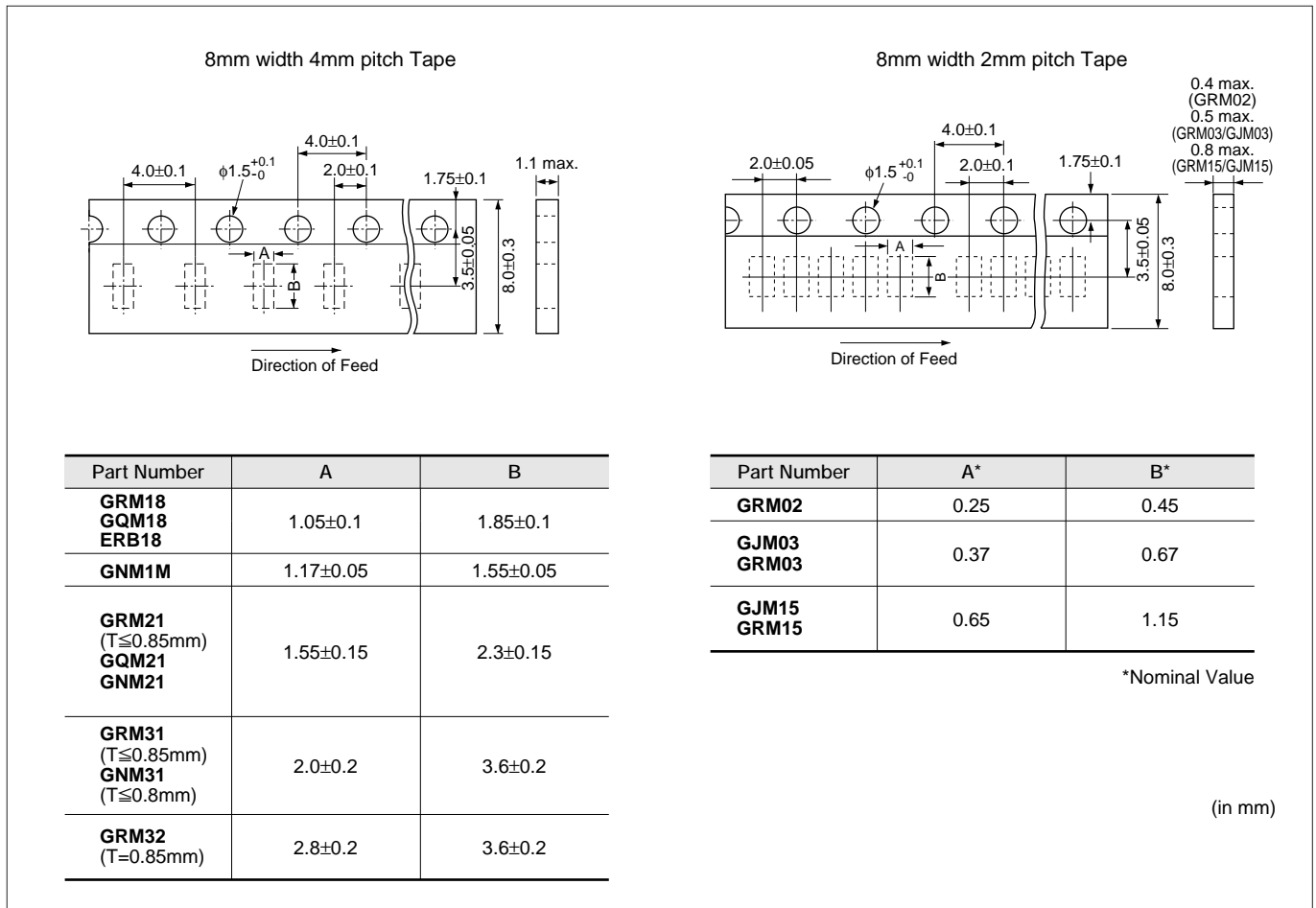

Continued on the following page. ↗

Continued from the preceding page.

(3) Dimensions of Plastic Tape

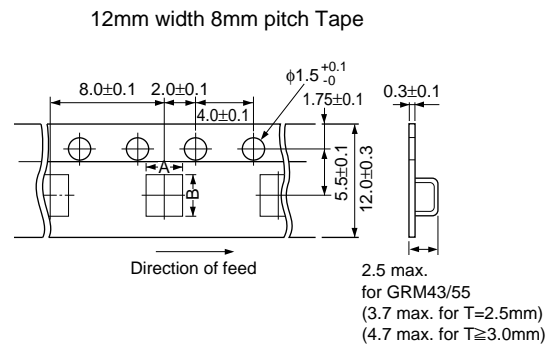
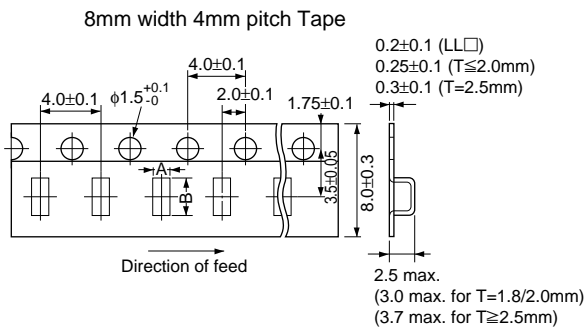

Part Number	A	B
LLL18, LLA18	1.05±0.1	1.85±0.1
GRM21 (T≥1.0mm) LLL21 LLA21, LLM21	1.45±0.2	2.25±0.2
GRM31 (T≥1.15mm) LLL31 LLA31, LLM31 GNM31 (T≥1.0mm)	1.9±0.2	3.5±0.2
GRM32 (T≥1.15mm)	2.8±0.2	3.5±0.2
ERB21	1.45*	2.25*
ERB32	2.9*	3.6*

Part Number	A*	B*
GRM43	3.6	4.9
GRM55	5.2	6.1

*Nominal Value

*Nominal Value

(in mm)

(4) Taping Method

- ① Tapes for capacitors are wound clockwise. The sprocket holes are to the right as the tape is pulled toward the user.
- ② Part of the leader and part of the empty tape should be attached to the end of the tape as follows.
- ③ The top tape and base tape are not attached at the end of the tape for a minimum of 5 pitches.
- ④ Missing capacitors number within 0.1% of the number per reel or 1 pc, whichever is greater, and are not continuous.
- ⑤ The top tape and bottom tape should not protrude beyond the edges of the tape and should not cover sprocket holes.
- ⑥ Cumulative tolerance of sprocket holes, 10 pitches: ±0.3mm.
- ⑦ Peeling off force: 0.1 to 0.6N* in the direction shown below.

}	*GRM02
	GRM03
	GJM03

 : 0.05 to 0.5N

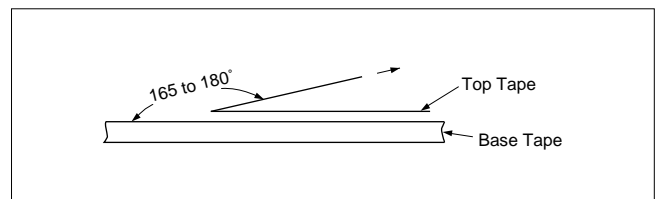
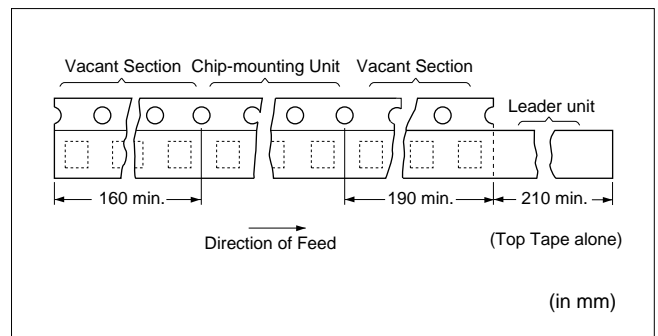

Continued on the following page. ↗

Continued from the preceding page.

■ Dimensions of Bulk Case Packaging

The bulk case uses antistatic materials. Please contact Murata for details.

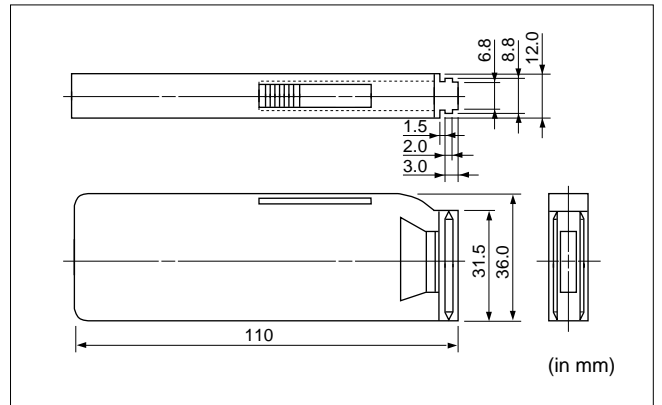

No.	Item	Specifications		Test Method																
		Temperature Compensating Type	High Dielectric Type																	
1	Operating Temperature Range	-55 to +125°C	B1, B3, F1, R6 : -25 to +85°C R1, R7 : -55 to +125°C E4 : +10 to +85°C F5 : -30 to +85°C	Reference temperature : 25°C (2Δ, 3Δ, 4Δ, B1, B3, F1, R1, R6 : 20°C)																
2	Rated Voltage	See the previous pages		The rated voltage is defined as the maximum voltage which may be applied continuously to the capacitor. When AC voltage is superimposed on DC voltage, V ^{P-P} or V ^{Q-P} , whichever is larger, should be maintained within the rated voltage range.																
3	Appearance	No defects or abnormalities		Visual inspection																
4	Dimensions	Within the specified dimensions		Using calipers																
5	Dielectric Strength	No defects or abnormalities		No failure should be observed when *300% of the rated voltage (temperature compensating type) or 250% of the rated voltage (high dielectric constant type) is applied between the terminations for 1 to 5 seconds, provided the charge/discharge current is less than 50mA. *200% for 500V																
6	Insulation Resistance	C ≤ 0.047μF : More than 10,000MΩ C > 0.047μF : 500Ω · F C : Nominal Capacitance		The insulation resistance should be measured with a DC voltage not exceeding the rated voltage at 20/25°C and 75%RH max. and within 2 minutes of charging, provided the charge/discharge current is less than 50mA.																
7	Capacitance	Within the specified tolerance		The capacitance/Q/D.F. should be measured at 20/25°C at the frequency and voltage shown in the table.																
8	Q/ Dissipation Factor (D.F.)	30pF and over : Q ≥ 1000 30pF and below : Q ≥ 400+20C C : Nominal Capacitance (pF)	[B1, B3, R1, R6, R7, E4, C8] W.V. : 25V min. : 0.025 max. W.V. : 16/10V : 0.035 max. W.V. : 6.3/4V : 0.05 max. (C < 3.3μF) W.V. : 0.1 max. (C ≥ 3.3μF) [F1, F5] W.V. : 25V min. : 0.05 max. (C < 0.1μF) W.V. : 0.09 max. (C ≥ 0.1μF) W.V. : 16/10V : 0.125 max. W.V. : 6.3V : 0.15 max.	<table border="1"> <thead> <tr> <th>Char.</th> <th>ΔC to ΔU, 1X (1000pF and below)</th> <th>ΔC to ΔU, 1X (more than 1000pF) R6, R7, F5 B1, B3, F1</th> <th>E4</th> </tr> </thead> <tbody> <tr> <td>Item</td> <td></td> <td></td> <td></td> </tr> <tr> <td>Frequency</td> <td>1±0.1MHz</td> <td>1±0.1kHz</td> <td>1±0.1kHz</td> </tr> <tr> <td>Voltage</td> <td>0.5 to 5Vrms</td> <td>1±0.2Vrms</td> <td>0.5±0.05Vrms</td> </tr> </tbody> </table>	Char.	ΔC to ΔU, 1X (1000pF and below)	ΔC to ΔU, 1X (more than 1000pF) R6, R7, F5 B1, B3, F1	E4	Item				Frequency	1±0.1MHz	1±0.1kHz	1±0.1kHz	Voltage	0.5 to 5Vrms	1±0.2Vrms	0.5±0.05Vrms
Char.	ΔC to ΔU, 1X (1000pF and below)	ΔC to ΔU, 1X (more than 1000pF) R6, R7, F5 B1, B3, F1	E4																	
Item																				
Frequency	1±0.1MHz	1±0.1kHz	1±0.1kHz																	
Voltage	0.5 to 5Vrms	1±0.2Vrms	0.5±0.05Vrms																	

Continued on the following page. 

Continued from the preceding page.

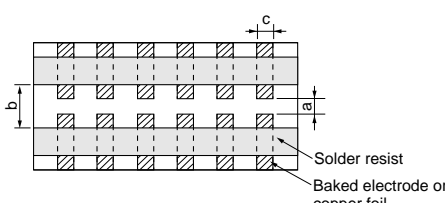
No.	Item	Specifications		Test Method																																								
		Temperature Compensating Type	High Dielectric Type																																									
9	Capacitance Temperature Characteristics	No bias	B1, B3 : Within $\pm 10\%$ (-25 to $+85^\circ\text{C}$) R1, R7 : Within $\pm 15\%$ (-55 to $+125^\circ\text{C}$) R6 : Within $\pm 15\%$ (-55 to $+85^\circ\text{C}$) E4 : Within $+22/-56\%$ ($+10$ to $+85^\circ\text{C}$) F1 : Within $+30/-80\%$ (-25 to $+85^\circ\text{C}$) F5 : Within $+22/-82\%$ (-30 to $+85^\circ\text{C}$) C8 : Within $\pm 22\%$ (-55 to $+105^\circ\text{C}$)	The capacitance change should be measured after 5 min. at each specified temp. stage. (1) Temperature Compensating Type The temperature coefficient is determined using the capacitance measured in step 3 as a reference. When cycling the temperature sequentially from step 1 through 5 ($5\text{C} : +25$ to $+125^\circ\text{C}/\Delta\text{C} : +20$ to $+125^\circ\text{C} : \text{other temp. coeffs.} : +25$ to $+85^\circ\text{C}/+20$ to $+85^\circ\text{C}$) the capacitance should be within the specified tolerance for the temperature coefficient and capacitance change as Table A-1. The capacitance drift is calculated by dividing the differences between the maximum and minimum measured values in the step 1, 3 and 5 by the cap. value in step 3.																																								
		50% of the Rated Voltage	B1 : Within $+10/-30\%$ R1 : Within $+15/-40\%$ F1 : Within $+30/-95\%$																																									
	Capacitance Drift	Within $\pm 0.2\%$ or $\pm 0.05\text{pF}$ (Whichever is larger.) *Not apply to 1X/25V	*Initial measurement for high dielectric constant type Perform a heat treatment at $150+0/-10^\circ\text{C}$ for one hour and then set for 48 ± 4 hours at room temperature. Perform the initial measurement.	(2) High Dielectric Constant Type The ranges of capacitance change compared with the 20°C value over the temperature ranges shown in the table should be within the specified ranges.* In case of applying voltage, the capacitance change should be measured after 1 more min. with applying voltage in equilibration of each temp. stage.																																								
				<table border="1"> <thead> <tr> <th>Step</th> <th>Temperature ($^\circ\text{C}$)</th> </tr> </thead> <tbody> <tr> <td>1</td> <td>Reference Temperature ± 2</td> </tr> <tr> <td>2</td> <td>-55 ± 3 (for ΔC)/-25 ± 3 (for other TC)</td> </tr> <tr> <td>3</td> <td>Reference Temperature ± 2</td> </tr> <tr> <td>4</td> <td>125 ± 3 (for ΔC)/85 ± 3 (for other TC)</td> </tr> <tr> <td>5</td> <td>Reference Temperature ± 2</td> </tr> </tbody> </table> <table border="1"> <thead> <tr> <th>Step</th> <th>Temperature ($^\circ\text{C}$)</th> <th>Applying Voltage (V)</th> </tr> </thead> <tbody> <tr> <td>1</td> <td>Reference Temperature ± 2</td> <td rowspan="3">No bias</td> </tr> <tr> <td>2</td> <td>-55 ± 3 (for R1, R7, R6) -25 ± 3 (for B1, B3, F1) -30 ± 3 (for F5)/10 ± 3 (for E4)</td> </tr> <tr> <td>3</td> <td>Reference Temperature ± 2</td> </tr> <tr> <td>4</td> <td>125 ± 3 (for R1, R7)/ 85 ± 3 (for B1, B3, R6 F1, F5, E4)</td> <td rowspan="4">50% of the rated voltage</td> </tr> <tr> <td>5</td> <td>Reference Temperature ± 2</td> </tr> <tr> <td>6</td> <td>-55 ± 3 (for R1)/ -25 ± 3 (for B1, F1)</td> </tr> <tr> <td>7</td> <td>Reference Temperature ± 2</td> </tr> <tr> <td>8</td> <td>125 ± 3 (for R1)/ 85 ± 3 (for B1, F1)</td> <td></td> </tr> </tbody> </table>	Step	Temperature ($^\circ\text{C}$)	1	Reference Temperature ± 2	2	-55 ± 3 (for ΔC)/ -25 ± 3 (for other TC)	3	Reference Temperature ± 2	4	125 ± 3 (for ΔC)/ 85 ± 3 (for other TC)	5	Reference Temperature ± 2	Step	Temperature ($^\circ\text{C}$)	Applying Voltage (V)	1	Reference Temperature ± 2	No bias	2	-55 ± 3 (for R1, R7, R6) -25 ± 3 (for B1, B3, F1) -30 ± 3 (for F5)/ 10 ± 3 (for E4)	3	Reference Temperature ± 2	4	125 ± 3 (for R1, R7)/ 85 ± 3 (for B1, B3, R6 F1, F5, E4)	50% of the rated voltage	5	Reference Temperature ± 2	6	-55 ± 3 (for R1)/ -25 ± 3 (for B1, F1)	7	Reference Temperature ± 2	8	125 ± 3 (for R1)/ 85 ± 3 (for B1, F1)							
Step	Temperature ($^\circ\text{C}$)																																											
1	Reference Temperature ± 2																																											
2	-55 ± 3 (for ΔC)/ -25 ± 3 (for other TC)																																											
3	Reference Temperature ± 2																																											
4	125 ± 3 (for ΔC)/ 85 ± 3 (for other TC)																																											
5	Reference Temperature ± 2																																											
Step	Temperature ($^\circ\text{C}$)	Applying Voltage (V)																																										
1	Reference Temperature ± 2	No bias																																										
2	-55 ± 3 (for R1, R7, R6) -25 ± 3 (for B1, B3, F1) -30 ± 3 (for F5)/ 10 ± 3 (for E4)																																											
3	Reference Temperature ± 2																																											
4	125 ± 3 (for R1, R7)/ 85 ± 3 (for B1, B3, R6 F1, F5, E4)	50% of the rated voltage																																										
5	Reference Temperature ± 2																																											
6	-55 ± 3 (for R1)/ -25 ± 3 (for B1, F1)																																											
7	Reference Temperature ± 2																																											
8	125 ± 3 (for R1)/ 85 ± 3 (for B1, F1)																																											
10	Adhesive Strength of Termination	No removal of the terminations or other defect should occur  Fig. 1a	Solder the capacitor to the test jig (glass epoxy board) shown in Fig. 1a using an eutectic solder. Then apply 10N^* force in parallel with the test jig for 10 ± 1 sec. The soldering should be done either with an iron or using the reflow method and should be conducted with care so that the soldering is uniform and free of defects such as heat shock. *1N (GRM02), 2N (GR□03), 5N (GR□15, GRM18)																																									
				<table border="1"> <thead> <tr> <th>Type</th> <th>a</th> <th>b</th> <th>c</th> </tr> </thead> <tbody> <tr> <td>GRM02</td> <td>0.2</td> <td>0.56</td> <td>0.23</td> </tr> <tr> <td>GR□03</td> <td>0.3</td> <td>0.9</td> <td>0.3</td> </tr> <tr> <td>GR□15</td> <td>0.4</td> <td>1.5</td> <td>0.5</td> </tr> <tr> <td>GRM18</td> <td>1.0</td> <td>3.0</td> <td>1.2</td> </tr> <tr> <td>GRM21</td> <td>1.2</td> <td>4.0</td> <td>1.65</td> </tr> <tr> <td>GRM31</td> <td>2.2</td> <td>5.0</td> <td>2.0</td> </tr> <tr> <td>GRM32</td> <td>2.2</td> <td>5.0</td> <td>2.9</td> </tr> <tr> <td>GRM43</td> <td>3.5</td> <td>7.0</td> <td>3.7</td> </tr> <tr> <td>GRM55</td> <td>4.5</td> <td>8.0</td> <td>5.6</td> </tr> </tbody> </table> (in mm)	Type	a	b	c	GRM02	0.2	0.56	0.23	GR□03	0.3	0.9	0.3	GR□15	0.4	1.5	0.5	GRM18	1.0	3.0	1.2	GRM21	1.2	4.0	1.65	GRM31	2.2	5.0	2.0	GRM32	2.2	5.0	2.9	GRM43	3.5	7.0	3.7	GRM55	4.5	8.0	5.6
Type	a	b	c																																									
GRM02	0.2	0.56	0.23																																									
GR□03	0.3	0.9	0.3																																									
GR□15	0.4	1.5	0.5																																									
GRM18	1.0	3.0	1.2																																									
GRM21	1.2	4.0	1.65																																									
GRM31	2.2	5.0	2.0																																									
GRM32	2.2	5.0	2.9																																									
GRM43	3.5	7.0	3.7																																									
GRM55	4.5	8.0	5.6																																									

Continued on the following page. 

● Part Numbering

Chip Monolithic Ceramic Capacitors

(Part Number)

GR	M	18	8	B1	1H	102	K	A01	K
①	②	③	④	⑤	⑥	⑦	⑧	⑨	⑩

① Product ID

② Series

Product ID	Code	Series
GR	M	Tin Plated Layer
	4	Only for Information Devices / Tip & Ring
	7	Only for Camera Flash Circuit
ER	B	High Frequency Type
GQ	M	High Frequency for Flow/Reflow Soldering
GM	A	Monolithic Microchip
GN	M	Capacitor Array
LL	L	Low ESL Wide Width Type
	C	Automotive Low ESL Wide Width Type
	A	Eight-termination Low ESL Type
	M	Ten-termination Low ESL Type
GJ	M	High Frequency Low Loss Type Tin Plated Type
	6	High Frequency Low Loss Type
GA	2	for AC250V (r.m.s.)
	3	Safety Standard Recognized Type
GC	P	Automotive Soldering Electrode
	M	Automotive Tin Plated Layer

③ Dimension (L×W)

Code	Dimension (L×W)	EIA
02	0.4×0.2mm	01005
03	0.6×0.3mm	0201
05	0.5×0.5mm	0202
08	0.8×0.8mm	0303
11	1.25×1.0mm	0504
15	1.0×0.5mm	0402
18	1.6×0.8mm	0603
1D	1.4×1.4mm	
1X	Depends on individual standards.	
21	2.0×1.25mm	0805
22	2.8×2.8mm	1111
31	3.2×1.6mm	1206
32	3.2×2.5mm	1210
3X	Depends on individual standards.	
42	4.5×2.0mm	1808
43	4.5×3.2mm	1812
52	5.7×2.8mm	2211
55	5.7×5.0mm	2220

④ Dimension (T)

Code	Dimension (T)
2	0.2mm
2	2-elements (Array Type)
3	0.3mm
4	4-elements (Array Type)
5	0.5mm
6	0.6mm
7	0.7mm
8	0.8mm
9	0.85mm
A	1.0mm
B	1.25mm
C	1.6mm
D	2.0mm
E	2.5mm
F	3.2mm
M	1.15mm
N	1.35mm
R	1.8mm
S	2.8mm
Q	1.5mm
X	Depends on individual standards.

With the array type GNM series, "Dimension(T)" indicates the number of elements.

Continued on the following page. 

Continued from the preceding page.

5 Temperature Characteristics

Temperature Characteristic Codes			Temperature Characteristics			Operating Temperature Range
Code	Public STD Code		Reference Temperature	Temperature Range	Capacitance Change or Temperature Coefficient	
1X	SL *1	JIS	20°C	20 to 85°C	+350 to -1000ppm/°C	-55 to 125°C
2C	CH *1	JIS	20°C	20 to 125°C	0±60ppm/°C	-55 to 125°C
2P	PH *1	JIS	20°C	20 to 85°C	-150±60ppm/°C	-25 to 85°C
2R	RH *1	JIS	20°C	20 to 85°C	-220±60ppm/°C	-25 to 85°C
2S	SH *1	JIS	20°C	20 to 85°C	-330±60ppm/°C	-25 to 85°C
2T	TH *1	JIS	20°C	20 to 85°C	-470±60ppm/°C	-25 to 85°C
3C	CJ *1	JIS	20°C	20 to 125°C	0±120ppm/°C	-55 to 125°C
3P	PJ *1	JIS	20°C	20 to 85°C	-150±120ppm/°C	-25 to 85°C
3R	RJ *1	JIS	20°C	20 to 85°C	-220±120ppm/°C	-25 to 85°C
3S	SJ *1	JIS	20°C	20 to 85°C	-330±120ppm/°C	-25 to 85°C
3T	TJ *1	JIS	20°C	20 to 85°C	-470±120ppm/°C	-25 to 85°C
3U	UJ *1	JIS	20°C	20 to 85°C	-750±120ppm/°C	-25 to 85°C
4C	CK *1	JIS	20°C	20 to 125°C	0±250ppm/°C	-55 to 125°C
5C	C0G *1	EIA	25°C	25 to 125°C	0±30ppm/°C	-55 to 125°C
5G	X8G *1	EIA	25°C	25 to 150°C	0±30ppm/°C	-55 to 150°C
6C	C0H *1	EIA	25°C	25 to 125°C	0±60ppm/°C	-55 to 125°C
6C	CH *1,*3	EIA	25°C	25 to 125°C	0±60ppm/°C	-55 to 125°C
6P	P2H *1	EIA	25°C	25 to 85°C	-150±60ppm/°C	-55 to 125°C
6R	R2H *1	EIA	25°C	25 to 85°C	-220±60ppm/°C	-55 to 125°C
6S	S2H *1	EIA	25°C	25 to 85°C	-330±60ppm/°C	-55 to 125°C
6T	T2H *1	EIA	25°C	25 to 85°C	-470±60ppm/°C	-55 to 125°C
7C	CJ *1*3	EIA	25°C	25 to 125°C	0±120ppm/°C	-55 to 125°C
7U	U2J *1	EIA	25°C	25 to 85°C	-750±120ppm/°C	-55 to 125°C
8C	CK *1,*3	EIA	25°C	25 to 125°C	0±250ppm/°C	-55 to 125°C
B1	B *2	JIS	20°C	-25 to 85°C	±10%	-25 to 85°C
B3	B	JIS	20°C	-25 to 85°C	±10%	-25 to 85°C
C7	X7S	EIA	25°C	-55 to 125°C	±22%	-55 to 125°C
E4	Z5U	EIA	25°C	10 to 85°C	+22, -56%	10 to 85°C
F1	F *2	JIS	20°C	-25 to 85°C	+30, -80%	-25 to 85°C
F5	Y5V	EIA	25°C	-30 to 85°C	+22, -82%	-30 to 85°C
L8	X8L	EIA	25°C	-55 to 150°C	+15, -40%	-55 to 150°C
R1	R *2	JIS	20°C	-55 to 125°C	±15%	-55 to 125°C
R3	R	JIS	20°C	-55 to 125°C	±15%	-55 to 125°C
R6	X5R	EIA	25°C	-55 to 85°C	±15%	-55 to 85°C
R7	X7R	EIA	25°C	-55 to 125°C	±15%	-55 to 125°C
R9	X8R	EIA	25°C	-55 to 150°C	±15%	-55 to 150°C
C8	X6S	EIA	25°C	-55 to 105°C	±22%	-55 to 105°C
9E	ZLM	*4	20°C	-25 to 20°C	-4700+100/-2500ppm/°C	-25 to 85°C
				20 to 85°C	-4700+500/-1000ppm/°C	
W0	-	-	25°C	-55 to 125°C	±10% *5	-55 to 125°C
					+22, -33% *6	

*1 Please refer to table for Capacitance Change under reference temperature.

*2 Capacitance change is specified with 50% rated voltage applied.

*3 ER series only.

*3,*4 Murata Temperature Characteristic Code.

*5 Apply DC350V bias.

*6 No DC bias.

Continued on the following page. 

Continued from the preceding page.

● Capacitance Change from each temperature

JIS Code

Murata Code	Capacitance Change from 20°C (%)					
	-55°C		-25°C		-10°C	
	Max.	Min.	Max.	Min.	Max.	Min.
1X	-	-	-	-	-	-
2C	0.82	-0.45	0.49	-0.27	0.33	-0.18
2P	-	-	1.32	0.41	0.88	0.27
2R	-	-	1.70	0.72	1.13	0.48
2S	-	-	2.30	1.22	1.54	0.81
2T	-	-	3.07	1.85	2.05	1.23
3C	1.37	-0.90	0.82	-0.54	0.55	-0.36
3P	-	-	1.65	0.14	1.10	0.09
3R	-	-	2.03	0.45	1.35	0.30
3S	-	-	2.63	0.95	1.76	0.63
3T	-	-	3.40	1.58	2.27	1.05
3U	-	-	4.94	2.84	3.29	1.89
4C	2.56	-1.88	1.54	-1.13	1.02	-0.75

EIA Code

Murata Code	Capacitance Change from 25°C (%)					
	-55°C		-30°C		-10°C	
	Max.	Min.	Max.	Min.	Max.	Min.
5C/5G	0.58	-0.24	0.40	-0.17	0.25	-0.11
6C	0.87	-0.48	0.59	-0.33	0.38	-0.21
6P	2.33	0.72	1.61	0.50	1.02	0.32
6R	3.02	1.28	2.08	0.88	1.32	0.56
6S	4.09	2.16	2.81	1.49	1.79	0.95
6T	5.46	3.28	3.75	2.26	2.39	1.44
7U	8.78	5.04	6.04	3.47	3.84	2.21

ER□ Series

Murata Code	Capacitance Change from 25°C (%)					
	-55°C		-30°C		-10°C	
	Max.	Min.	Max.	Min.	Max.	Min.
5C	0.43	-0.22	0.28	-0.16	0.17	-0.11
6C	0.73	-0.44	0.48	-0.32	0.29	-0.20
7C	1.33	-0.93	0.88	-0.64	0.54	-0.42
8C	2.61	-0.97	1.73	-1.36	1.07	-0.86

Continued on the following page. 

Continued from the preceding page.

⑥ Rated Voltage

Code	Rated Voltage
0G	DC4V
0J	DC6.3V
1A	DC10V
1C	DC16V
1E	DC25V
1H	DC50V
2A	DC100V
2D	DC200V
2E	DC250V
YD	DC300V
2H	DC500V
2J	DC630V
3A	DC1kV
3D	DC2kV
3F	DC3.15kV
BB	DC350V (for Camera Flash Circuit)
E2	AC250V
GB	X2; AC250V (Safety Standard Recognized Type GB)
GC	X1/Y2; AC250V (Safety Standard Recognized Type GC)
GD	Y3; AC250V (Safety Standard Recognized Type GD)
GF	Y2, X1/Y2; AC250V (Safety Standard Recognized Type GF)

⑧ Capacitance Tolerance

Code	Capacitance Tolerance	TC	Series	Capacitance Step	
B	±0.1pF	CΔ	GJM	≤5pF	E24 Series, 1pF
C	±0.25pF	CΔ-SL	GRM/ERB/GQM	≤5pF	* 1pF
		CΔ	GJM	<10pF	E24 Series, 1pF
D	±0.5pF	CΔ-SL	GRM	6.0 to 9.0pF	* 1pF
		CΔ	ERB/GQM/GJM	5.1 to 9.1pF	E24 Series
F	±1%	CΔ	GRM03/15/GJM03/15	5.0 to 9.9pF	0.1pF
G	±2%	CΔ	GJM	≥10pF	E12 Series
		CΔ	GQM	≥10pF	E24 Series
		CΔ	GRM03/15/GJM03/15	2.0 to 9.9pF	0.1pF
J	±5%	CΔ-SL	GRM/GA3	≥10pF	E12 Series
		CΔ	ERB/GQM/GJM	≥10pF	E24 Series
		CΔ	GRM03/15/GJM03/15	1.0 to 4.9pF	0.1pF
K	±10%	B, R, X7R, X5R, ZLM	GRM/GR7/GA3	E6 Series	
			GR4	E12 Series	
M	±20%	CΔ	GRM03/15/GJM03/15	0.2 to 1.9pF	0.1pF
		Z5U	GRM	E3 Series	
		B, R, X7R, X7S	GRM/GMA/LLL/LLC/LLA/LLM	E6 Series	
		X7R	GA2	E3 Series	
Z	+80%, -20%	CΔ	GRM03/15/GJM03/15	0.1 to 0.9pF	0.1pF
R		F, Y5V	GRM	E3 Series	
Depends on individual standards.					

* E24 series is also available.

⑨ Individual Specification Code

Expressed by three figures.

⑦ Capacitance

Expressed by three figures. The unit is pico-farad (pF). The first and second figures are significant digits, and the third figure expresses the number of zeros which follow the two numbers. If there is a decimal point, it is expressed by the capital letter "R". In this case, all figures are significant digits.

Ex.)

Code	Capacitance
R50	0.5pF
1R0	1.0pF
100	10pF
103	10000pF

Continued on the following page. 

Continued from the preceding page.

Packaging

Code	Packaging
L	ø178mm Plastic Taping
D	ø178mm Paper Taping
K	ø330mm Plastic Taping
J	ø330mm Paper Taping
E	ø178mm Special Packaging
F	ø330mm Special Packaging
B	Bulk
C	Bulk Case
T	Bulk Tray