

High Voltage 1.5A, 200kHz Step-Down Switching Regulator with 100 μ A Quiescent Current

FEATURES

- **Wide Input Range: 3.3V to 60V**
- **1.5A Peak Switch Current**
- **Burst Mode[®] Operation: 100 μ A Quiescent Current****
- **Low Shutdown Current: $I_Q < 1\mu$ A**
- **Power Good Flag with Programmable Threshold**
- **Load Dump Protection to 60V**
- 200kHz Switching Frequency
- Saturating Switch Design: 0.2 Ω On-Resistance
- Peak Switch Current Maintained Over Full Duty Cycle Range*
- 1.25V Feedback Reference Voltage
- Easily Synchronizable
- Soft-Start Capability
- Small 16-Pin Thermally Enhanced TSSOP Package

APPLICATIONS

- High Voltage Power Conversion
- 14V and 42V Automotive Systems
- Industrial Power Systems
- Distributed Power Systems
- Battery-Powered Systems

LT, LTC and LT are registered trademarks of Linear Technology Corporation. Burst Mode is a registered trademark of Linear Technology Corporation. All other trademarks are the property of their respective owners.

*Protected by U.S. Patents, including 6498466

**See Burst Mode Operation section for conditions

DESCRIPTION

The LT[®]1976 is a 200kHz monolithic buck switching regulator that accepts input voltages up to 60V. A high efficiency 1.5A, 0.2 Ω switch is included on the die along with all the necessary oscillator, control and logic circuitry. Current mode topology is used for fast transient response and good loop stability.

Innovative design techniques along with a new high voltage process achieve high efficiency over a wide input range. Efficiency is maintained over a wide output current range by employing Burst Mode operation at low currents, utilizing the output to bias the internal circuitry, and by using a supply boost capacitor to fully saturate the power switch. Patented circuitry maintains peak switch current over the full duty cycle range.* Shutdown reduces input supply current to less than 1 μ A. External synchronization can be implemented by driving the SYNC pin with logic-level inputs. A single capacitor from the C_{SS} pin to the output provides a controlled output voltage ramp (soft-start). The device also has a power good flag with a programmable threshold and time-out and thermal shutdown protection.

The LT1976 is available in a 16-pin TSSOP package with Exposed Pad leadframe for low thermal resistance. The LT1977, a 500kHz increased switch frequency version of the LT1976, is also available. See the Applications Information section for selection criteria between the LT1976 and LT1977.

TYPICAL APPLICATION

14V to 3.3V Step-Down Converter with 100 μ A No Load Quiescent Current

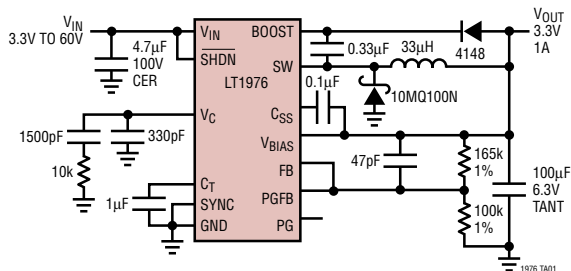

Supply Current vs Input Voltage

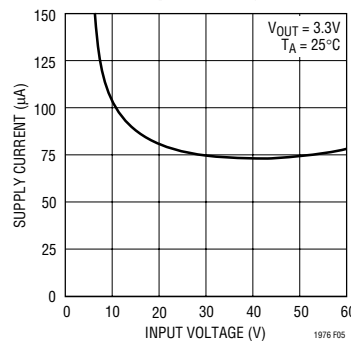

Efficiency and Power Loss vs Load Current

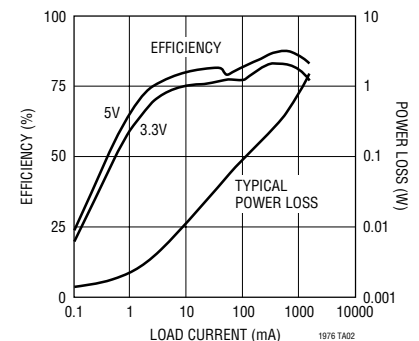

1976fb

ABSOLUTE MAXIMUM RATINGS

(Note 1)

V_{IN} , SHDN, BIAS	60V
BOOST Pin Above SW	35V
BOOST Pin Voltage	68V
SYNC, C_{SS} , PGFB, FB	6V
Operating Junction Temperature Range	
LT1976EFE (Note 2)	-40°C to 125°C
LT1976IFE (Note 2)	-40°C to 125°C
LT1976HFE (Note 2)	-40°C to 140°C
Storage Temperature Range	-65°C to 150°C
Lead Temperature (Soldering, 10 sec)	300°C

PACKAGE/ORDER INFORMATION

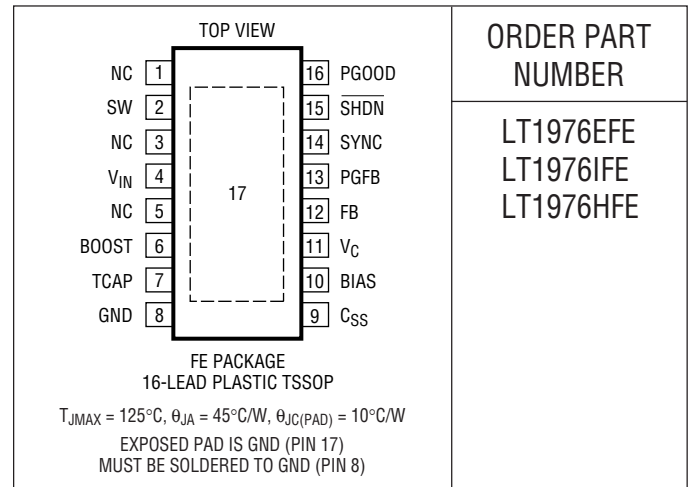

ORDER PART NUMBER

LT1976EFE
LT1976IFE
LT1976HFE

Consult LTC Marketing for parts specified with wider operating temperature ranges.

ELECTRICAL CHARACTERISTICS

The ● denotes the specifications which apply over the full -40°C to 125°C operating temperature range, otherwise specifications are at $T_J = 25^{\circ}\text{C}$. $V_{IN} = 12\text{V}$, SHDN = 12V, BOOST = 15.3V, BIAS = 5V, FB/PGFB = 1.25V, $C_{SS}/\text{SYNC} = 0\text{V}$ unless otherwise noted.

SYMBOL	PARAMETER	CONDITIONS	MIN	TYP	MAX	UNITS	
V_{SHDN}	SHDN Threshold		● 1.2	1.3	1.4	V	
I_{SHDN}	SHDN Input Current	SHDN = 12V	●	5	20	μA	
	Minimum Input Voltage (Note 3)		●	2.4	3	V	
I_{VINS}	Supply Shutdown Current	SHDN = 0V, BOOST = 0V, FB/PGFB = 0V		0.1	2	μA	
	Supply Sleep Current (Note 4)	BIAS = 0V, FB = 1.35V	●	170	230	μA	
		FB = 1.35V	●	45	75	μA	
I_{VIN}	Supply Quiescent Current	BIAS = 0V, FB = 1.15V, $V_C = 0.8\text{V}$		3.2	4.10	mA	
		BIAS = 5V, FB = 1.15V, $V_C = 0.8\text{V}$		2.6	3.25	mA	
	Minimum BIAS Voltage (Note 5)		●	2.7	3	V	
I_{BIASS}	BIAS Sleep Current (Note 4)		●	110	180	μA	
I_{BIAS}	BIAS Quiescent Current	SYNC = 3.3V		700	800	μA	
	Minimum Boost Voltage (Note 6)	$I_{SW} = 1.5\text{A}$		1.8	2.5	V	
	Input Boost Current (Note 7)	$I_{SW} = 1.5\text{A}$		40	50	mA	
V_{REF}	Reference Voltage (V_{REF})	$3.3\text{V} < V_{VIN} < 60\text{V}$	● 1.225	1.25	1.275	V	
I_{FB}	FB Input Bias Current			75	200	nA	
	EA Voltage Gain (Note 8)			900		V/V	
	EA Voltage g_m	$dI(V_C) = \pm 10\mu\text{A}$		400	650	800	μMho
	EA Source Current	FB = 1.15V		20	40	55	μA
	EA Sink Current	FB = 1.35V		15	30	40	μA
	V_C to SW g_m			3		A/V	
	V_C High Clamp			2.1	2.2	2.4	V
I_{PK}	SW Current Limit		● 1.5	2.4	3.5	A	

ELECTRICAL CHARACTERISTICS The ● denotes the specifications which apply over the full -40°C to 125°C operating temperature range, otherwise specifications are at $T_J = 25^{\circ}\text{C}$. $V_{IN} = 12\text{V}$, $\text{SHDN} = 12\text{V}$, $\text{BOOST} = 15.3\text{V}$, $\text{BIAS} = 5\text{V}$, $\text{FB}/\text{PGFB} = 1.25\text{V}$, $\text{C}_{\text{SS}}/\text{SYNC} = 0\text{V}$ unless otherwise noted.

SYMBOL	PARAMETER	CONDITIONS	MIN	TYP	MAX	UNITS	
	Switch On Resistance (Note 9)		●	0.2	0.4	Ω	
	Switching Frequency		●	180	200	230	kHz
	Maximum Duty Cycle			90	92		%
	Minimum SYNC Amplitude			1.5	2.0		V
	SYNC Frequency Range			600			kHz
	SYNC Input Impedance			85			$\text{k}\Omega$
I_{CSS}	C_{SS} Current Threshold (Note 10)			7	13	20	μA
I_{PGFB}	PGFB Input Current			25	100		nA
V_{PGFB}	PGFB Voltage Threshold (Note 11)		●	88	90	92	%
I_{CT}	C_T Source Current (Note 11)		●	2	3.6	5.5	μA
	C_T Sink Current (Note 11)			1	2		mA
V_{CT}	C_T Voltage Threshold (Note 11)			1.16	1.2	1.26	V
	PG Leakage (Note 11)			0.1	1		μA
	PG Sink Current (Note 11)	PGFB = 1V, PG = 400mV		120	200		μA

The ● denotes the specifications which apply over the full -40°C to 140°C operating temperature range, otherwise specifications are at $T_J = 25^{\circ}\text{C}$. $V_{IN} = 12\text{V}$, $\text{SHDN} = 12\text{V}$, $\text{BOOST} = 15.3\text{V}$, $\text{BIAS} = 5\text{V}$, $\text{FB}/\text{PGFB} = 1.25\text{V}$, $\text{C}_{\text{SS}}/\text{SYNC} = 0\text{V}$ unless otherwise noted.

SYMBOL	PARAMETER	CONDITIONS	MIN	TYP	MAX	UNITS	
V_{SHDN}	$\overline{\text{SHDN}}$ Threshold		●	1.2	1.3	1.4	V
I_{SHDN}	$\overline{\text{SHDN}}$ Input Current	$\overline{\text{SHDN}} = 12\text{V}$	●	5	20		μA
	Minimum Input Voltage (Note 3)		●	2.4	3		V
I_{VINS}	Supply Shutdown Current	$\overline{\text{SHDN}} = 0\text{V}$, $\text{BOOST} = 0\text{V}$, $\text{FB}/\text{PGFB} = 0\text{V}$		0.1	2		μA
	Supply Sleep Current (Note 4)	$\text{BIAS} = 0\text{V}$, $\text{FB} = 1.35\text{V}$ $\text{FB} = 1.35\text{V}$	●	170	300		μA
			●	45	100		μA
I_{VIN}	Supply Quiescent Current	$\text{BIAS} = 0\text{V}$, $\text{FB} = 1.15\text{V}$, $V_C = 0.8\text{V}$ $\text{BIAS} = 5\text{V}$, $\text{FB} = 1.15\text{V}$, $V_C = 0.8\text{V}$		3.2	4.10		mA
				2.6	3.25		mA
	Minimum BIAS Voltage (Note 5)		●	2.7	3		V
I_{BIASS}	BIAS Sleep Current (Note 4)		●	110	180		μA
I_{BIAS}	BIAS Quiescent Current	$\text{SYNC} = 3.3\text{V}$		700	800		μA
	Minimum Boost Voltage (Note 6)	$I_{\text{SW}} = 1.5\text{A}$		1.8	2.5		V
	Input Boost Current (Note 7)	$I_{\text{SW}} = 1.5\text{A}$		40	50		mA
V_{REF}	Reference Voltage (V_{REF})	$3.3\text{V} < V_{\text{VIN}} < 60\text{V}$	●	1.212	1.25	1.288	V
I_{FB}	FB Input Bias Current			75	200		nA
	EA Voltage Gain (Note 8)			900			V/V
	EA Voltage g_m	$dI(V_C) = \pm 10\mu\text{A}$		400	650	800	μMho
	EA Source Current	$\text{FB} = 1.15\text{V}$		20	40	55	μA
	EA Sink Current	$\text{FB} = 1.35\text{V}$		15	30	40	μA
	V_C to SW g_m			3			A/V
	V_C High Clamp			2.1	2.2	2.4	V
I_{PK}	SW Current Limit			2.4			A

ELECTRICAL CHARACTERISTICS

The ● denotes the specifications which apply over the full -40°C to 140°C operating temperature range, otherwise specifications are at $T_J = 25^{\circ}\text{C}$. $V_{IN} = 12\text{V}$, $\text{SHDN} = 12\text{V}$, $\text{BOOST} = 15.3\text{V}$, $\text{BIAS} = 5\text{V}$, $\text{FB}/\text{PGFB} = 1.25\text{V}$, $\text{C}_{\text{SS}}/\text{SYNC} = 0\text{V}$ unless otherwise noted.

SYMBOL	PARAMETER	CONDITIONS	MIN	TYP	MAX	UNITS	
	Switch On Resistance (Note 9)		●	0.2	0.6	Ω	
	Switching Frequency		●	150	200	260	kHz
	Maximum Duty Cycle			90	92		%
	Minimum SYNC Amplitude			1.5	2.0		V
	SYNC Frequency Range			600			kHz
	SYNC Input Impedance			85			$\text{k}\Omega$
I_{CSS}	C_{SS} Current Threshold (Note 10)			7	13	20	μA
I_{PGFB}	PGFB Input Current			25	100		nA
V_{PGFB}	PGFB Voltage Threshold (Note 11)		●	87	90	93	%
I_{CT}	C_T Source Current (Note 11)		●	1.5	3.6	5.5	μA
	C_T Sink Current (Note 11)			1	2		mA
V_{CT}	C_T Voltage Threshold (Note 11)			1.16	1.2	1.26	V
	PG Leakage (Note 11)			0.1	1		μA
	PG Sink Current (Note 11)	PGFB = 1V, PG = 400mV		120	200		μA

Note 1: Absolute Maximum Ratings are those values beyond which the life of a device may be impaired.

Note 2: The LT1976EFE is guaranteed to meet performance specifications from 0°C to 125°C junction temperature. Specifications over the -40°C to 125°C operating junction temperature range are assured by design, characterization and correlation with statistical process controls. The LT1976IFE/LT1976HFE are guaranteed and tested over the full -40°C to 125°C operating junction temperature range. The LT1976HFE is also tested to the LT1976HFE electrical characteristics table at 140°C operating junction temperature.

Note 3: Minimum input voltage is defined as the voltage where switching starts. Actual minimum input voltage to maintain a regulated output will depend upon output voltage and load current. See Applications Information.

Note 4: Supply input current is the quiescent current drawn by the input pin. Its typical value depends on the voltage on the BIAS pin and operating state of the LT1976. With the BIAS pin at 0V, all of the quiescent current required to operate the LT1976 will be provided by the V_{IN} pin. With the BIAS voltage above its minimum input voltage, a portion of the total quiescent current will be supplied by the BIAS pin. Supply sleep current is defined as the quiescent current during the "sleep" portion of Burst Mode operation. See Applications Information for determining application supply currents.

Note 5: Minimum BIAS voltage is the voltage on the BIAS pin when I_{BIAS} is sourced into the pin.

Note 6: This is the minimum voltage across the boost capacitor needed to guarantee full saturation of the internal power switch.

Note 7: Boost current is the current flowing into the BOOST pin with the pin held 3.3V above input voltage. It flows only during switch on time.

Note 8: Gain is measured with a V_C swing from 1.15V to 750mV.

Note 9: Switch on resistance is calculated by dividing V_{IN} to SW voltage by the forced current (1.5A). See Typical Performance Characteristics for the graph of switch voltage at other currents.

Note 10: The C_{SS} threshold is defined as the value of current sourced into the C_{SS} pin which results in an increase in sink current from the V_C pin. See the Soft-Start section in Applications Information.

Note 11: The PGFB threshold is defined as the percentage of V_{REF} voltage which causes the current source output of the C_T pin to change from sinking (below threshold) to sourcing current (above threshold). When sourcing current, the voltage on the C_T pin rises until it is clamped internally. When the clamp is activated, the output of the PG pin will be set to a high impedance state. When the C_T clamp is inactive the PG pin will be set active low with a current sink capability of 200 μA .

Note 12: High junction temperatures degrade operating lifetimes. Operating lifetime at junction temperatures between 125°C and 140°C is derated to 1000 hours.

TYPICAL PERFORMANCE CHARACTERISTICS

FB Voltage

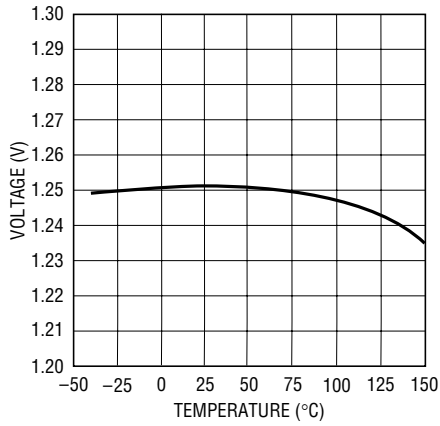

1976 G01

Oscillator Frequency

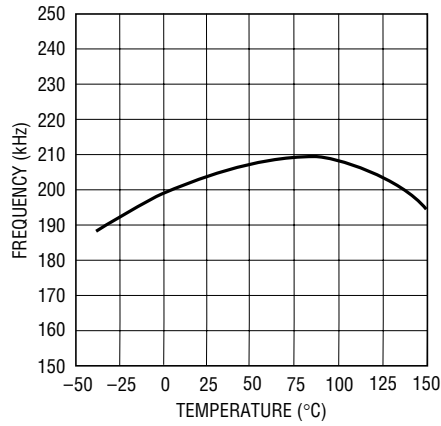

1976 G02

SHDN Threshold

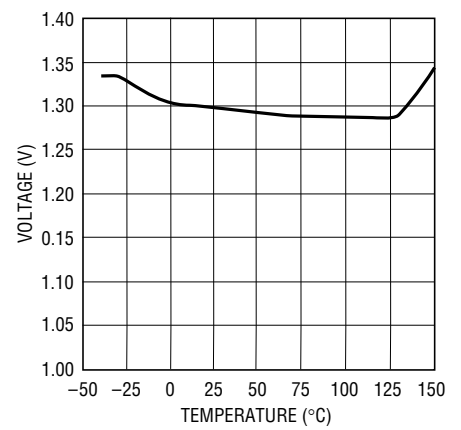

1976 G03

SHDN Pin Current

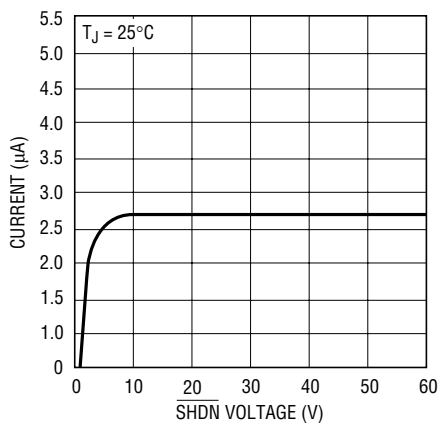

1976 G04

Shutdown Supply Current

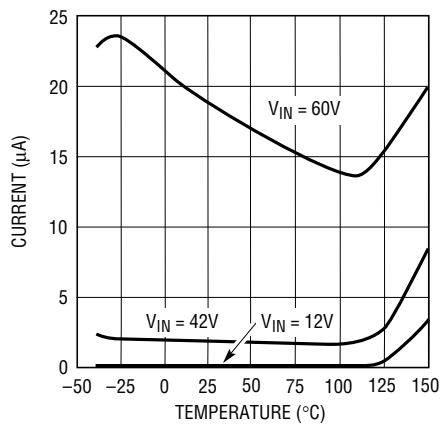

1976 G05

Sleep Mode Supply Current

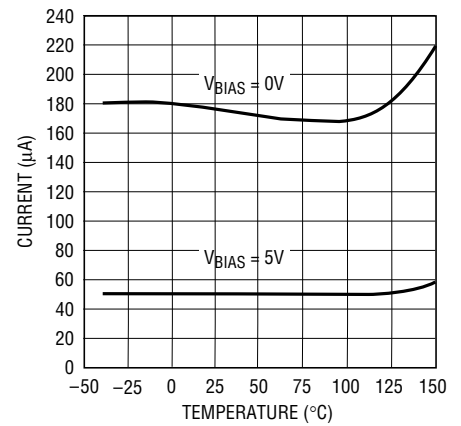

1976 G06

Bias Sleep Current

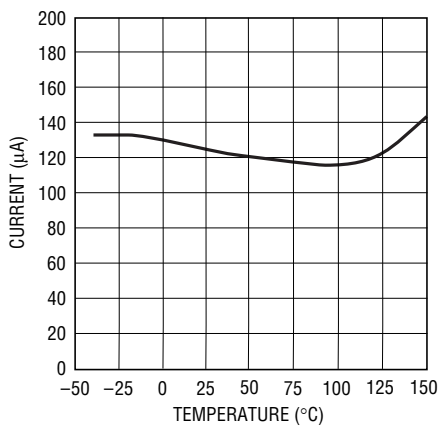

1976 G07

PGFB Threshold

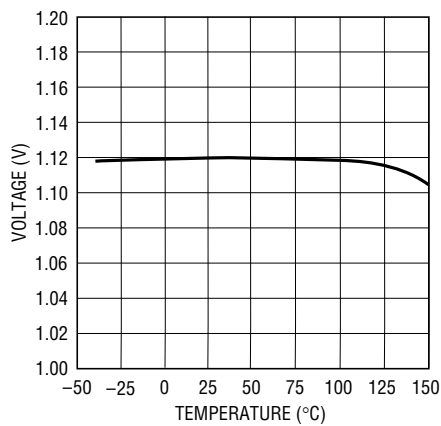

1976 G08

PG Sink Current

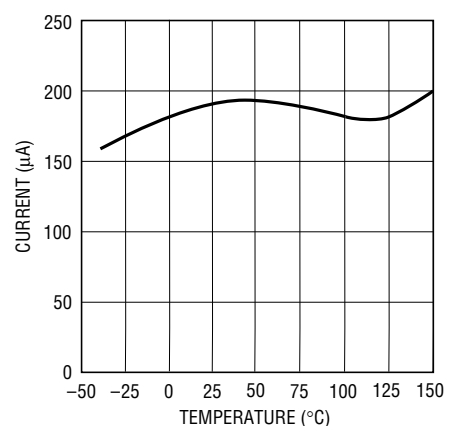

1976 G08

TYPICAL PERFORMANCE CHARACTERISTICS

Switch Peak Current Limit

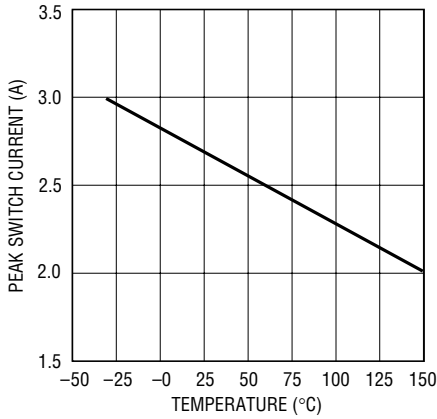

1976 G10

Soft-Start Current Threshold vs FB Voltage

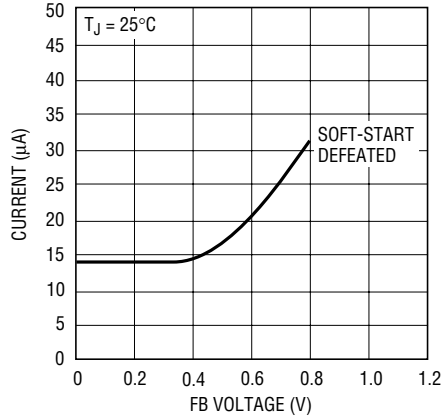

1976 G11

Oscillator Frequency vs FB Voltage

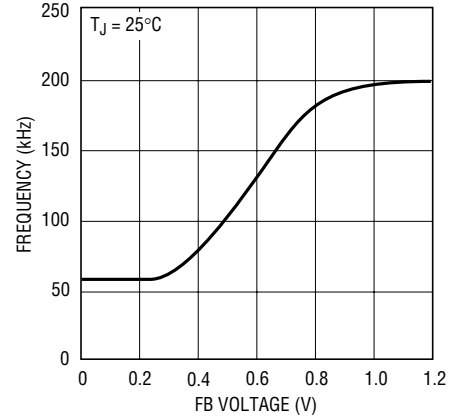

1976 G12

Switch On Voltage (V_{CESAT})

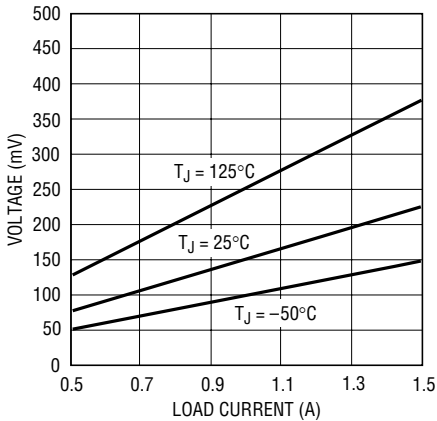

1976 G13

Supply Current vs Input Voltage

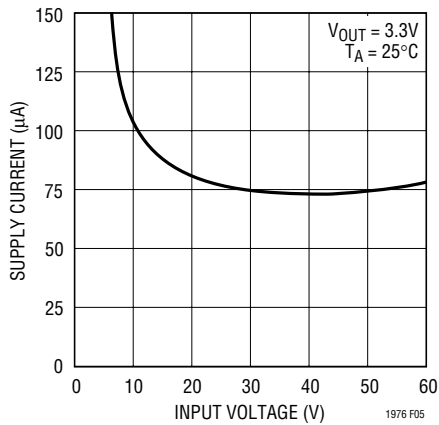

1976 F05

Minimum Input Voltage

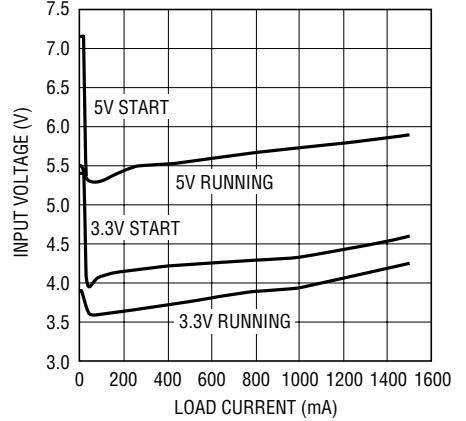

1976 G19

Burst Mode Threshold vs Input Voltage

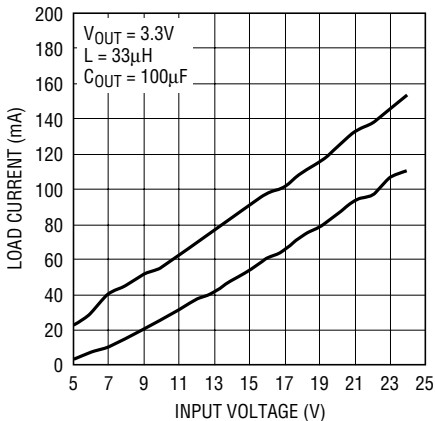

1975 G20

Minimum On Time

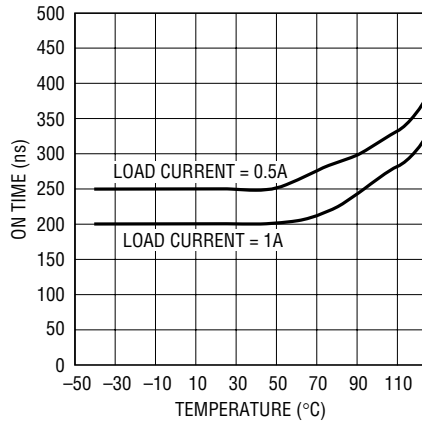

1976 G21

Boost Current vs Load Current

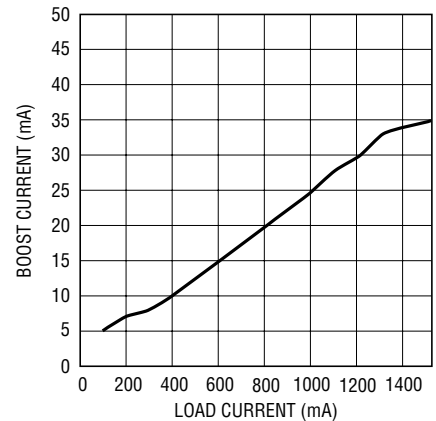

1976 G22

TYPICAL PERFORMANCE CHARACTERISTICS

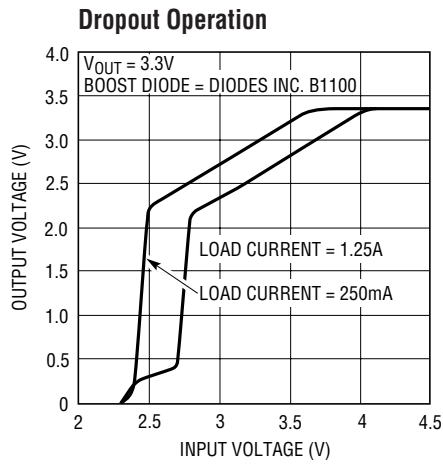

1976 G23

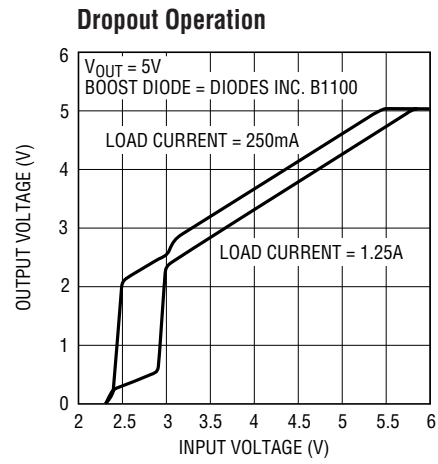

1976 G24

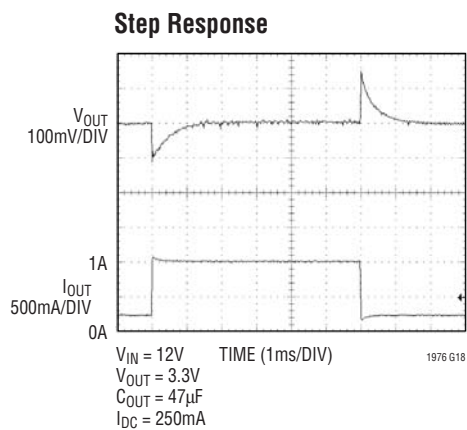
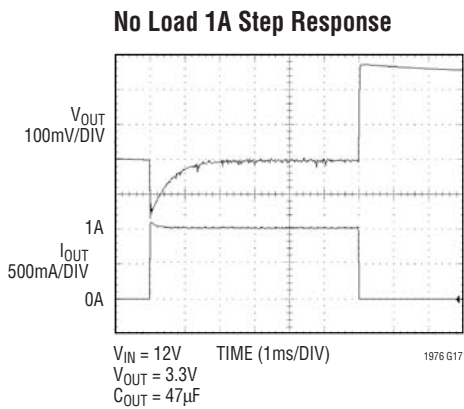
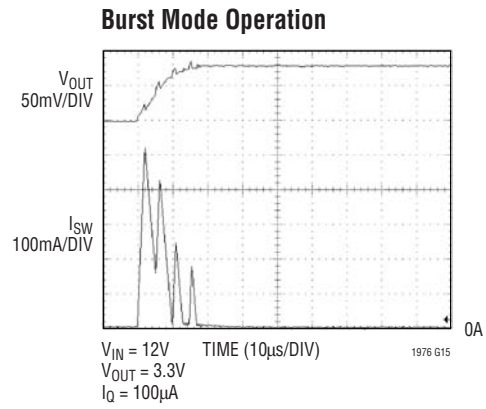
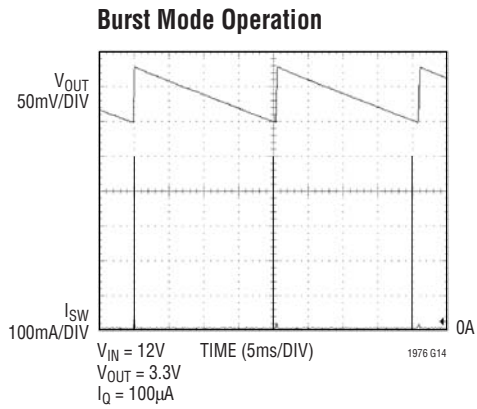

PIN FUNCTIONS

NC (Pins 1, 3, 5): No Connection.

SW (Pin 2): The SW pin is the emitter of the on-chip power NPN switch. This pin is driven up to the input pin voltage during switch on time. Inductor current drives the SW pin negative during switch off time. Negative voltage is clamped with the external catch diode. Maximum negative switch voltage allowed is $-0.8V$.

V_{IN} (Pin 4): This is the collector of the on-chip power NPN switch. V_{IN} powers the internal control circuitry when a voltage on the BIAS pin is not present. High di/dt edges occur on this pin during switch turn on and off. Keep the path short from the V_{IN} pin through the input bypass capacitor, through the catch diode back to SW. All trace inductance on this path will create a voltage spike at switch off, adding to the V_{CE} voltage across the internal NPN.

BOOST (Pin 6): The BOOST pin is used to provide a drive voltage, higher than the input voltage, to the internal bipolar NPN power switch. Without this added voltage, the typical switch voltage loss would be about $1.5V$. The additional BOOST voltage allows the switch to saturate and its voltage loss approximates that of a 0.2Ω FET structure, but with much smaller die area.

C_T (Pin 7): A capacitor on the C_T pin determines the amount of delay time between the PGFB pin exceeding its threshold (V_{PGFB}) and the PG pin set to a high impedance state. When the PGFB pin rises above V_{PGFB} , current is sourced from the C_T pin into the external capacitor. When the voltage on the external capacitor reaches an internal clamp (V_{CT}), the PG pin becomes a high impedance node. The resultant PG delay time is given by $t = C_{CT} \cdot V_{CT} / I_{CT}$. If the voltage on the PGFB pin drops below V_{PGFB} , C_{CT} will be discharged rapidly to 0V and PG will be active low with a $200\mu A$ sink capability. If the C_T pin is clamped (Power Good condition) during normal operation and SHDN is taken low, the C_T pin will be discharged and a delay period will occur when SHDN is returned high. See the Power Good section in Applications Information for details.

GND (Pins 8, 17): The GND pin connection acts as the reference for the regulated output, so load regulation will suffer if the “ground” end of the load is not at the same voltage as the GND pin of the IC. This condition will occur when load current or other currents flow through metal paths between the GND pin and the load ground. Keep the path between the GND pin and the load ground short and use a ground plane when possible. The GND pin also acts as a heat sink and should be soldered (along with the exposed leadframe) to the copper ground plane to reduce thermal resistance (see Applications Information).

C_{SS} (Pin 9): A capacitor from the C_{SS} pin to the regulated output voltage determines the output voltage ramp rate during start-up. When the current through the C_{SS} capacitor exceeds the C_{SS} threshold (I_{CSS}), the voltage ramp of the output is limited. The C_{SS} threshold is proportional to the FB voltage (see Typical Performance Characteristics) and is defeated for FB voltage greater than $0.9V$ (typical). See Soft-Start section in Applications Information for details.

BIAS (Pin 10): The BIAS pin is used to improve efficiency when operating at higher input voltages and light load current. Connecting this pin to the regulated output voltage forces most of the internal circuitry to draw its operating current from the output voltage rather than the input supply. This architecture increases efficiency especially when the input voltage is much higher than the output. Minimum output voltage setting for this mode of operation is $3V$.

V_C (Pin 11): The V_C pin is the output of the error amplifier and the input of the peak switch current comparator. It is normally used for frequency compensation, but can also serve as a current clamp or control loop override. V_C sits at about $0.45V$ for light loads and $2.2V$ at maximum load. During the sleep portion of Burst Mode operation, the V_C pin is held at a voltage slightly below the burst threshold for better transient response. Driving the V_C pin to ground will disable switching and place the IC into sleep mode.

PIN FUNCTIONS

FB (Pin 12): The feedback pin is used to determine the output voltage using an external voltage divider from the output that generates 1.25V at the FB pin. When the FB pin drops below 0.9V, switching frequency is reduced, the SYNC function is disabled and output ramp rate control is enabled via the C_{SS} pin. See the Feedback section in Applications Information for details.

PGFB (PIN 13): The PGFB pin is the positive input to a comparator whose negative input is set at V_{PGFB}. When PGFB is taken above V_{PGFB}, current (I_{CSS}) is sourced into the C_T pin starting the PG delay period. When the voltage on the PGFB pin drops below V_{PGFB}, the C_T pin is rapidly discharged resetting the PG delay period. The PGFB voltage is typically generated by a resistive divider from the regulated output or input supply. See Power Good section in Applications Information for details.

SYNC (Pin 14): The SYNC pin is used to synchronize the internal oscillator to an external signal. It is directly logic

compatible and can be driven with any signal between 20% and 80% duty cycle. The synchronizing range is equal to maximum initial operating frequency up to 700kHz. When the voltage on the FB pin is below 0.9V the SYNC function is disabled. See the Synchronizing section in Applications Information for details.

SHDN (Pin 15): The $\overline{\text{SHDN}}$ pin is used to turn off the regulator and to reduce input current to less than 1 μ A. The $\overline{\text{SHDN}}$ pin requires a voltage above 1.2V with a typical source current of 3 μ A to take the IC out of the shutdown state.

PG (Pin 16): The PG pin is functional only when the $\overline{\text{SHDN}}$ pin is above its threshold, and is active low when the internal clamp on the C_T pin is below its clamp level and high impedance when the clamp is active. The PG pin has a typical sink capability of 200 μ A. See the Power Good section in Applications Information for details.

BLOCK DIAGRAM

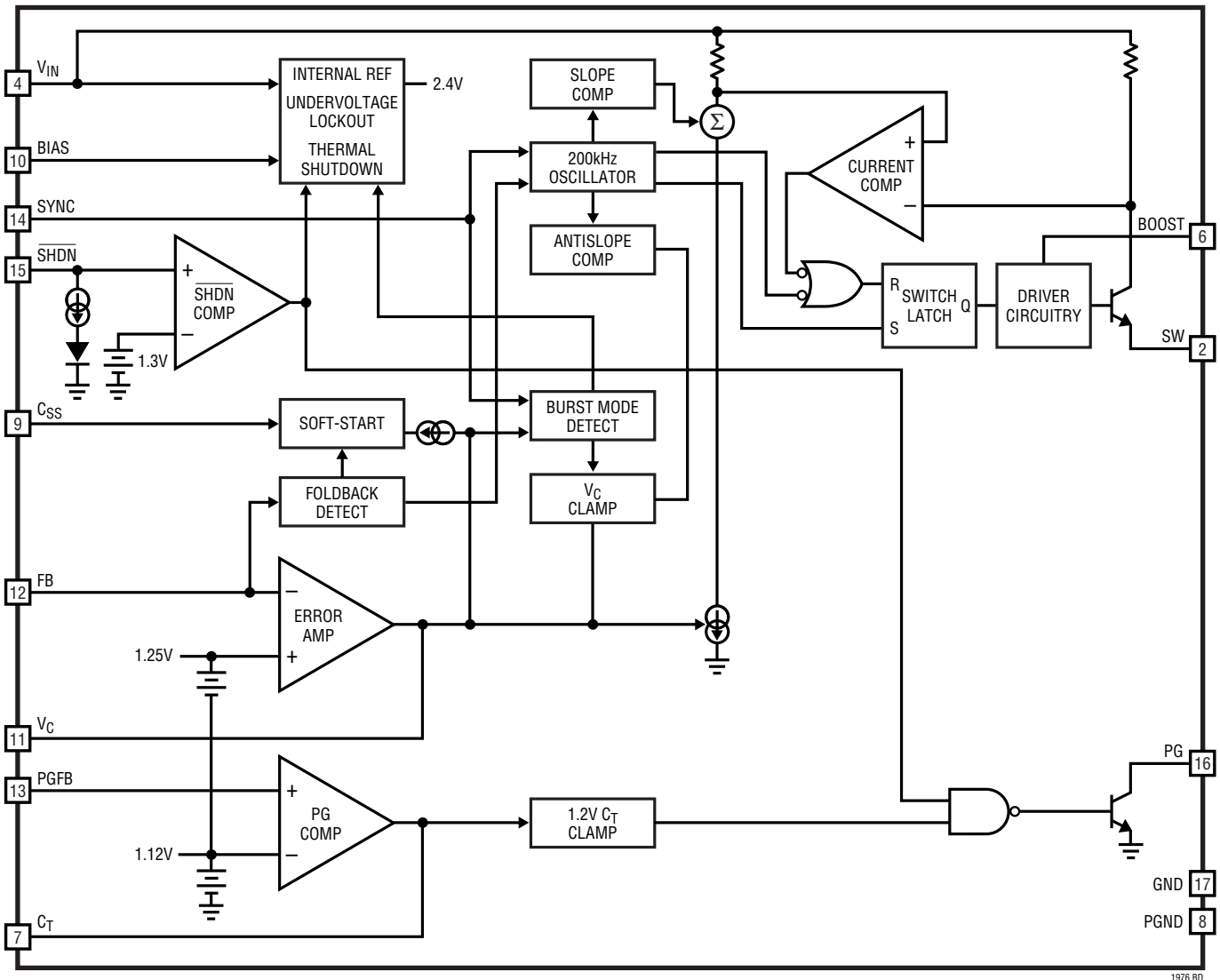

Figure 1. LT1976 Block Diagram

The LT1976 is a constant frequency, current mode buck converter. This means that there is an internal clock and two feedback loops that control the duty cycle of the power switch. In addition to the normal error amplifier, there is a current sense amplifier that monitors switch current on a cycle-by-cycle basis. A switch cycle starts with an oscillator pulse which sets the RS latch to turn the switch on. When switch current reaches a level set by the current comparator the latch is reset and the switch turns off. Output voltage control is obtained by using the output of the error amplifier to set the switch current trip point. This technique means that the error amplifier commands current to be

delivered to the output rather than voltage. A voltage fed system will have low phase shift up to the resonant frequency of the inductor and output capacitor, then an abrupt 180° shift will occur. The current fed system will have 90° phase shift at a much lower frequency, but will not have the additional 90° shift until well beyond the LC resonant frequency. This makes it much easier to frequency compensate the feedback loop and also gives much quicker transient response.

Most of the circuitry of the LT1976 operates from an internal 2.4V bias line. The bias regulator normally draws

BLOCK DIAGRAM

power from the V_{IN} pin, but if the BIAS pin is connected to an external voltage higher than 3V bias power will be drawn from the external source (typically the regulated output voltage). This improves efficiency.

High switch efficiency is attained by using the BOOST pin to provide a voltage to the switch driver which is higher than the input voltage, allowing switch to be saturated. This boosted voltage is generated with an external capacitor and diode.

To further optimize efficiency, the LT1976 automatically switches to Burst Mode operation in light load situations. In Burst Mode operation, all circuitry associated with controlling the output switch is shut down reducing the input supply current to 45 μ A.

The LT1976 contains a power good flag with a programmable threshold and delay time. A logic-level low on the SHDN pin disables the IC and reduces input supply current to less than 1 μ A.

APPLICATIONS INFORMATION

CHOOSING THE LT1976 OR LT1977

The LT1976 and LT1977 are both high voltage 1.5A step-down Burst Mode switching regulators with a typical quiescent current of 100 μ A. The difference between the two is that the fixed switching frequency of the LT1976 is 200kHz versus 500kHz for the LT1977. The switching frequency affects: inductor size, input voltage range in continuous mode operation, efficiency, thermal loss and EMI.

OUTPUT RIPPLE AND INDUCTOR SIZE

Output ripple current is determined by the input to output voltage ratio, inductor value and switch frequency. Since the switch frequency of the LT1977 is 2.5 times greater than that of the LT1976, the inductance used in the LT1977 application can be 2.5 times lower than the LT1976 while maintaining the same output ripple current. The lower value used in the LT1977 application allows the use of a physically smaller inductor.

INPUT VOLTAGE RANGE

The LT1976 and LT1977 minimum on and off times are equivalent. This results in a narrower range of continuous mode operation for the LT1977. Typical minimum and maximum duty cycles are 6% to 95% for the LT1976 and 15% to 90% for the LT1977. Both parts will regulate up to an input voltage of 60V but the LT1977 will transition into

pulse skipping/Burst Mode operation when the input voltage is above 30V for a 5V output. At outputs above 10V the LT1977's input range will be similar to the LT1976. Lowering the input voltage below the maximum duty cycle limitation will cause a dropout in regulation.

Table 1. LT1976/LT1977 Comparison

PARAMETER	ADVANTAGE
Minimum Duty Cycle	LT1976
Maximum Duty Cycle	LT1976
Inductor Size	LT1977
Output Capacitor Size	LT1977
Efficiency	LT1976
EMI	LT1976
Input Range	LT1976
Output Ripple	LT1977

FEEDBACK PIN FUNCTIONS

The feedback (FB) pin on the LT1976 is used to set output voltage and provide several overload protection features. The first part of this section deals with selecting resistors to set output voltage and the remaining part talks about frequency foldback and soft-start features. Please read both parts before committing to a final design.

Referring to Figure 2, the output voltage is determined by a voltage divider from V_{OUT} to ground which generates 1.25V at the FB pin. Since the output divider is a load on the

APPLICATIONS INFORMATION

with 0.9V present at the FB pin. The soft-start function does not affect operation during normal load conditions. However, if a momentary short (brown out condition) is present at the output which causes the FB voltage to drop below 0.9V, the soft-start circuitry will become active.

INPUT CAPACITOR

Step-down regulators draw current from the input supply in pulses. The rise and fall times of these pulses are very fast. The input capacitor is required to reduce the voltage ripple this causes at the input of LT1976 and force the switching current into a tight local loop, thereby minimizing EMI. The RMS ripple current can be calculated from:

$$I_{\text{RIPPLE(RMS)}} = \frac{I_{\text{OUT}}}{V_{\text{IN}}} \sqrt{V_{\text{OUT}}(V_{\text{IN}} - V_{\text{OUT}})}$$

Ceramic capacitors are ideal for input bypassing. At 200kHz switching frequency input capacitor values in the range of 4.7μF to 20μF are suitable for most applications. If operation is required close to the minimum input required by the LT1976 a larger value may be required. This is to prevent excessive ripple causing dips below the minimum operating voltage resulting in erratic operation.

Input voltage transients caused by input voltage steps or by hot plugging the LT1976 to a pre-powered source such as a wall adapter can exceed maximum V_{IN} ratings. The sudden application of input voltage will cause a large surge of current in the input leads that will store energy in the parasitic inductance of the leads. This energy will cause the input voltage to swing above the DC level of input power source and it may exceed the maximum voltage rating of the input capacitor and LT1976. All input voltage transient sequences should be observed at the V_{IN} pin of the LT1976 to ensure that absolute maximum voltage ratings are not violated.

The easiest way to suppress input voltage transients is to add a small aluminum electrolytic capacitor in parallel with the low ESR input capacitor. The selected capacitor needs to have the right amount of ESR to critically damp the resonant circuit formed by the input lead inductance and the input capacitor. The typical values of ESR will fall in the

range of 0.5Ω to 2Ω and capacitance will fall in the range of 5μF to 50μF.

If tantalum capacitors are used, values in the 22μF to 470μF range are generally needed to minimize ESR and meet ripple current and surge ratings. Care should be taken to ensure the ripple and surge ratings are not exceeded. The AVX TPS and Kemet T495 series are surge rated AVX recommends derating capacitor operating voltage by 2:1 for high surge applications.

OUTPUT CAPACITOR

The output capacitor is normally chosen by its effective series resistance (ESR) because this is what determines output ripple voltage. To get low ESR takes volume, so physically smaller capacitors have higher ESR. The ESR range for typical LT1976 applications is 0.05Ω to 0.2Ω. A typical output capacitor is an AVX type TPS, 100μF at 10V, with a guaranteed ESR less than 0.1Ω. This is a “D” size surface mount solid tantalum capacitor. TPS capacitors are specially constructed and tested for low ESR, so they give the lowest ESR for a given volume. The value in microfarads is not particularly critical and values from 22μF to greater than 500μF work well, but you cannot cheat Mother Nature on ESR. If you find a tiny 22μF solid tantalum capacitor, it will have high ESR and output ripple voltage could be unacceptable. Table 3 shows some typical solid tantalum surface mount capacitors.

Table 3. Surface Mount Solid Tantalum Capacitor ESR and Ripple Current

E CASE SIZE	ESR MAX (Ω)	RIPPLE CURRENT (A)
AVX TPS	0.1 to 0.3	0.7 to 1.1
D CASE SIZE		
AVX TPS	0.1 to 0.3	0.7 to 1.1
C CASE SIZE		
AVX TPS	0.2	0.5

Many engineers have heard that solid tantalum capacitors are prone to failure if they undergo high surge currents. This is historically true and type TPS capacitors are specially tested for surge capability but surge ruggedness is not a critical issue with the output capacitor. Solid

APPLICATIONS INFORMATION

tantalum capacitors fail during very high turn-on surges which do not occur at the output of regulators. High discharge surges, such as when the regulator output is dead shorted, do not harm the capacitors.

Unlike the input capacitor RMS, ripple current in the output capacitor is normally low enough that ripple current rating is not an issue. The current waveform is triangular with a typical value of $200\text{mA}_{\text{RMS}}$. The formula to calculate this is:

Output capacitor ripple current (RMS)

$$I_{\text{RIPPLE(RMS)}} = \frac{0.29(V_{\text{OUT}})(V_{\text{IN}} - V_{\text{OUT}})}{(L)(f)(V_{\text{IN}})} = \frac{I_{\text{P-P}}}{\sqrt{12}}$$

CERAMIC CAPACITORS

Higher value, lower cost ceramic capacitors are now becoming available. They are generally chosen for their good high frequency operation, small size and very low ESR (effective series resistance). Low ESR reduces output ripple voltage but also removes a useful zero in the loop frequency response, common to tantalum capacitors. To compensate for this a resistor R_C can be placed in series with the V_C compensation capacitor C_C (Figure 10). Care must be taken however since this resistor sets the high frequency gain of the error amplifier including the gain at the switching frequency. If the gain of the error amplifier is high enough at the switching frequency output ripple voltage (although smaller for a ceramic output capacitor) may still affect the proper operation of the regulator. A filter capacitor C_F in parallel with the R_C/C_C network, along with a small feedforward capacitor C_{FB} , is suggested to control possible ripple at the V_C pin. The LT1976 can be stabilized using a $47\mu\text{F}$ ceramic output capacitor and V_C component values of $C_C = 0.047\mu\text{F}$, $R_C = 12.5\text{k}$, $C_F = 100\text{pF}$ and $C_{\text{FB}} = 27\text{pF}$.

OUTPUT RIPPLE VOLTAGE

Figure 3 shows a typical output ripple voltage waveform for the LT1976. Ripple voltage is determined by the impedance of the output capacitor and ripple current through the inductor. Peak-to-peak ripple current through the inductor into the output capacitor is:

$$I_{\text{P-P}} = \frac{V_{\text{OUT}}(V_{\text{IN}} - V_{\text{OUT}})}{(V_{\text{IN}})(L)(f)}$$

For high frequency switchers the ripple current slew rate is also relevant and can be calculated from:

$$\frac{di}{dt} = \frac{V_{\text{IN}}}{L}$$

Peak-to-peak output ripple voltage is the sum of a triwave created by peak-to-peak ripple current times ESR and a square wave created by parasitic inductance (ESL) and ripple current slew rate. Capacitive reactance is assumed to be small compared to ESR or ESL.

$$V_{\text{RIPPLE}} = (I_{\text{P-P}})(\text{ESR}) + (\text{ESL})\frac{di}{dt}$$

Example: with $V_{\text{IN}} = 12\text{V}$, $V_{\text{OUT}} = 3.3\text{V}$, $L = 33\mu\text{H}$, $\text{ESR} = 0.08\Omega$, $\text{ESL} = 10\text{nH}$:

$$I_{\text{P-P}} = \frac{(3.3)(12 - 3.3)}{(12)(33\text{e} - 6)(200\text{e}3)} = 0.362\text{A}$$

$$\frac{di}{dt} = \frac{12}{3.3\text{e} - 5} = 3.63\text{e}5$$

$$V_{\text{RIPPLE}} = (0.362\text{A})(0.08) + (10\text{e} - 9)(363\text{e}3) = 0.0289 + 0.003 = 32\text{mV}_{\text{P-P}}$$

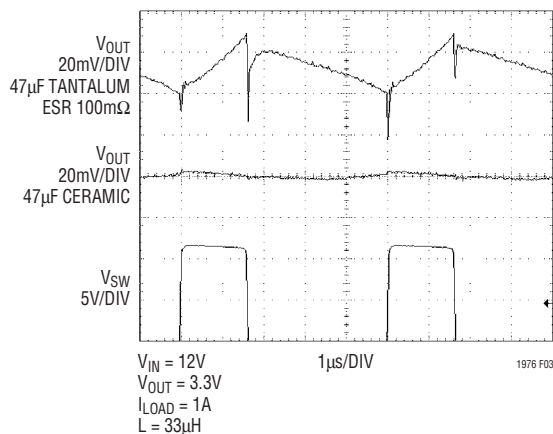

Figure 3. LT1976 Ripple Voltage Waveform

APPLICATIONS INFORMATION

MAXIMUM OUTPUT LOAD CURRENT

Maximum load current for a buck converter is limited by the maximum switch current rating (I_{PK}). The current rating for the LT1976 is 1.5A. Unlike most current mode converters, the LT1976 maximum switch current limit does not fall off at high duty cycles. Most current mode converters suffer a drop off of peak switch current for duty cycles above 50%. This is due to the effects of slope compensation required to prevent subharmonic oscillations in current mode converters. (For detailed analysis, see Application Note 19.)

The LT1976 is able to maintain peak switch current limit over the full duty cycle range by using patented circuitry to cancel the effects of slope compensation on peak switch current without affecting the frequency compensation it provides.

Maximum load current would be equal to maximum switch current for an infinitely large inductor, but with finite inductor size, maximum load current is reduced by one-half peak-to-peak inductor current. The following formula assumes continuous mode operation, implying that the term on the right ($I_{P-P}/2$) is less than I_{OUT} .

$$I_{OUT(MAX)} = I_{PK} - \frac{(V_{OUT})(V_{IN} - V_{OUT})}{2(L)(f)(V_{IN})} = I_{PK} - \frac{I_{P-P}}{2}$$

Discontinuous operation occurs when:

$$I_{OUT(DIS)} \leq \frac{V_{OUT}(V_{IN} - V_{OUT})}{2(L)(f)(V_{IN})}$$

For $V_{OUT} = 5V$, $V_{IN} = 8V$ and $L = 20\mu H$:

$$I_{OUT(MAX)} = 1.5 - \frac{(5)(8-5)}{2(20e-6)(200e3)(8)} \\ = 1.5 - 0.24 = 1.26A$$

Note that there is less load current available at the higher input voltage because inductor ripple current increases. At $V_{IN} = 15V$, duty cycle is 33% and for the same set of conditions:

$$I_{OUT(MAX)} = 1.5 - \frac{(5)(15-5)}{2(20e-6)(200e3)(15)} \\ = 1.5 - 0.42 = 1.08A$$

To calculate actual peak switch current in continuous mode with a given set of conditions, use:

$$I_{SW(PK)} = I_{OUT} + \frac{V_{OUT}(V_{IN} - V_{OUT})}{2(L)(f)(V_{IN})}$$

If a small inductor is chosen which results in discontinuous mode operation over the entire load range, the maximum load current is equal to:

$$I_{OUT(MAX)} = \frac{I_{PK}^2 2(f)(L)(V_{IN})}{2(V_{OUT})(V_{IN} - V_{OUT})}$$

CHOOSING THE INDUCTOR

For most applications the output inductor will fall in the range of $15\mu H$ to $100\mu H$. Lower values are chosen to reduce physical size of the inductor. Higher values allow more output current because they reduce peak current seen by the LT1976 switch, which has a 1.5A limit. Higher values also reduce output ripple voltage and reduce core loss.

When choosing an inductor you might have to consider maximum load current, core and copper losses, allowable component height, output voltage ripple, EMI, fault current in the inductor, saturation and of course cost. The following procedure is suggested as a way of handling these somewhat complicated and conflicting requirements.

APPLICATIONS INFORMATION

1. Choose a value in microhenries from the graph of maximum load current. Choosing a small inductor with lighter loads may result in discontinuous mode of operation, but the LT1976 is designed to work well in either mode.

Table 4. Inductor Selection Criteria

VENDOR/ PART NUMBER	VALUE (μH)	I _{RMS} (A)	DCR (Ω)	HEIGHT (mm)
Coiltronics				
UP2B-150	15	2.4	0.041	6
UP2B-330	33	1.7	0.062	6
UP2B-470	47	1.4	0.139	6
UP2B-680	68	1.2	0.179	6
UP2B-101	100	0.95	0.271	6
UP3B-150	15	3.9	0.032	6.8
UP3B-330	33	2.4	0.069	6.8
UP3B-470	47	1.9	0.101	6.8
UP3B-680	68	1.6	0.156	6.8
UP3B-101	100	1.4	0.205	6.8
Sumida				
CDRH8D28-150M	15	2.2	0.053	3
CDRH124-150M	15	3.2	0.05	4.5
CDRH127-150M	15	4.5	0.02	8
CDRH8D28-330M	33	1.4	0.122	3
CDRH124-330M	33	2.7	0.97	4.5
CDRH127-330M	33	3.0	0.048	8
CDRH8D28-470M	47	1.25	0.150	3
CDRH125-470M	47	1.8	0.058	6
CDRH127-470M	47	2.5	0.076	8
CDRH124-680M	68	1.5	0.228	4.5
CDRH127-680M	68	2.1	0.1	8
CDRH124-101M	100	1.2	0.30	4.5
CDRH127-101M	100	1.7	0.17	8
Coilcraft				
DT3308P-153	15	2.0	0.1	3
DT3308P-333	33	1.4	0.3	3
DT3308P-473	47	1	0.47	3

Assume that the average inductor current is equal to load current and decide whether or not the inductor must withstand continuous fault conditions. If maximum load current is 0.5A, for instance, a 0.5A inductor may not survive a continuous 2A overload condition.

For applications with a duty cycle above 50%, the inductor value should be chosen to obtain an inductor ripple current of less than 40% of the peak switch current.

2. Calculate peak inductor current at full load current to ensure that the inductor will not saturate. Peak current can be significantly higher than output current, especially with smaller inductors and lighter loads, so don't omit this step. Powdered iron cores are forgiving because they saturate softly, whereas ferrite cores saturate abruptly. Other core materials fall somewhere in between. The following formula assumes continuous mode of operation, but it errs only slightly on the high side for discontinuous mode, so it can be used for all conditions.

$$I_{PEAK} = I_{OUT} + \frac{V_{OUT}(V_{IN} - V_{OUT})}{2(f)(L)(V_{IN})}$$

V_{IN} = maximum input voltage

f = switching frequency, 200kHz

3. Decide if the design can tolerate an “open” core geometry like a rod or barrel, which have high magnetic field radiation, or whether it needs a closed core like a toroid to prevent EMI problems. This is a tough decision because the rods or barrels are temptingly cheap and small and there are no helpful guidelines to calculate when the magnetic field radiation will be a problem.
4. After making an initial choice, consider the secondary things like output voltage ripple, second sourcing, etc. Use the experts in the Linear Technology's applications department if you feel uncertain about the final choice. They have experience with a wide range of inductor types and can tell you about the latest developments in low profile, surface mounting, etc.

APPLICATIONS INFORMATION

Short-Circuit Considerations

The LT1976 is a current mode controller. It uses the V_C node voltage as an input to a current comparator which turns off the output switch on a cycle-by-cycle basis as this peak current is reached. The internal clamp on the V_C node, nominally 2.2V, then acts as an output switch peak current limit. This action becomes the switch current limit specification. The maximum available output power is then determined by the switch current limit.

A potential controllability problem could occur under short-circuit conditions. If the power supply output is short circuited, the feedback amplifier responds to the low output voltage by raising the control voltage, V_C , to its peak current limit value. Ideally, the output switch would be turned on, and then turned off as its current exceeded the value indicated by V_C . However, there is finite response time involved in both the current comparator and turn-off of the output switch. These result in a minimum on time $t_{ON(MIN)}$. When combined with the large ratio of V_{IN} to $(V_F + I \cdot R)$, the diode forward voltage plus inductor $I \cdot R$ voltage drop, the potential exists for a loss of control. Expressed mathematically the requirement to maintain control is:

$$f \cdot t_{ON} \leq \frac{V_F + I \cdot R}{V_{IN}}$$

where:

f = switching frequency

t_{ON} = switch on time

V_F = diode forward voltage

V_{IN} = Input voltage

$I \cdot R$ = inductor $I \cdot R$ voltage drop

If this condition is not observed, the current will not be limited at I_{PK} but will cycle-by-cycle ratchet up to some higher value. Using the nominal LT1976 clock frequency of 200kHz, a V_{IN} of 40V and a $(V_F + I \cdot R)$ of say 0.7V, the maximum t_{ON} to maintain control would be approximately 90ns, an unacceptably short time.

The solution to this dilemma is to slow down the oscillator to allow the current in the inductor to drop to a sufficiently low value such that the current doesn't continue to ratchet higher. When the FB pin voltage is abnormally low thereby indicating some sort of short-circuit condition, the oscillator frequency will be reduced. Oscillator frequency is reduced by a factor of 4 when the FB pin voltage is below 0.4V and increases linearly to its typical value of 200kHz at a FB voltage of 0.95V (see Typical Performance Characteristics). In addition, if the current in the switch exceeds 1.5 $\cdot I_{PK}$ current demanded by the V_C pin, the LT1976 will skip the next on cycle effectively reducing the oscillator frequency by a factor of 2. These oscillator frequency reductions during short-circuit conditions allow the LT1976 to maintain current control.

SOFT-START

For applications where $[V_{IN}/(V_{OUT} + V_F)]$ ratios > 10 or large input surge currents can't be tolerated, the LT1976 soft-start feature should be used to control the output capacitor charge rate during start-up, or during recovery from an output short circuit thereby adding additional control over peak inductor current. The soft-start function limits the switch current via the V_C pin to maintain a constant voltage ramp rate (dV/dt) at the output capacitor. A capacitor (C_1 in Figure 2) from the C_{SS} pin to the regulated output voltage determines the output voltage ramp rate. When the current through the C_{SS} capacitor exceeds the C_{SS} threshold (I_{CSS}), the voltage ramp of the output capacitor is limited by reducing the V_C pin voltage. The C_{SS} threshold is proportional to the FB voltage (see Typical Performance Characteristics) and is defeated for FB voltages greater than 0.9V (typical). The output dV/dt can be approximated by:

$$\frac{dV}{dt} = \frac{I_{CSS}}{C_{SS}}$$

but actual values will vary due to start-up load conditions, compensation values and output capacitor selection.

APPLICATIONS INFORMATION

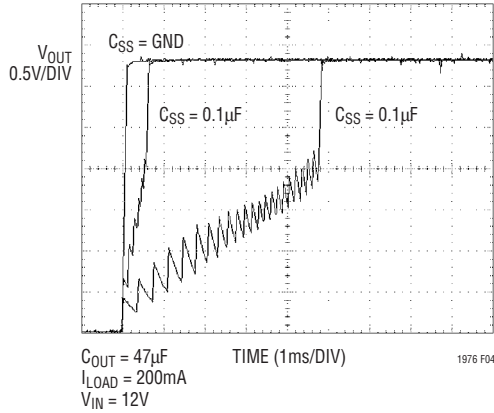

Figure 4. V_{OUT} dV/dt

Burst Mode OPERATION

To enhance efficiency at light loads, the LT1976 automatically switches to Burst Mode operation which keeps the output capacitor charged to the proper voltage while minimizing the input quiescent current. During Burst Mode operation, the LT1976 delivers short bursts of current to the output capacitor followed by sleep periods where the output power is delivered to the load by the output capacitor. In addition, V_{IN} and BIAS quiescent currents are reduced to typically 45µA and 125µA respectively during the sleep time. As the load current decreases towards a no load condition, the percentage of time that the LT1976 operates in sleep mode increases and the average input current is greatly reduced resulting in higher efficiency.

The minimum average input current depends on the V_{IN} to V_{OUT} ratio, V_C frequency compensation, feedback divider network and Schottky diode leakage. It can be approximated by the following equation:

$$I_{IN(AVG)} \cong I_{VINS} + I_{SHDN} + \left(\frac{V_{OUT}}{V_{IN}} \right) \frac{(I_{BIASS} + I_{FB} + I_S)}{\eta}$$

where

- I_{VINS} = input pin current in sleep mode
- V_{OUT} = output voltage
- V_{IN} = input voltage
- I_{BIASS} = BIAS pin current in sleep mode
- I_{FB} = feedback network current
- I_S = catch diode reverse leakage at V_{OUT}
- η = low current efficiency (non Burst Mode operation)

Example: For V_{OUT} = 3.3V, V_{IN} = 12V

$$I_{IN(AVG)} = 45\mu A + 5\mu A + \left(\frac{3.3}{12} \right) \frac{(125\mu A + 12.5\mu A + 0.5\mu A)}{(0.8)}$$

$$= 45\mu A + 5\mu A + 44\mu A = 99\mu A$$

During the sleep portion of the Burst Mode cycle, the V_C pin voltage is held just below the level needed for normal operation to improve transient response. See the Typical Performance Characteristics section for burst and transient response waveforms.

If a no load condition can be anticipated, the supply current can be further reduced by cycling the SHDN pin at a rate higher than the natural no load burst frequency. Figure 6 shows Burst Mode operation with the SHDN pin. V_{OUT} burst ripple is maintained while the average supply current

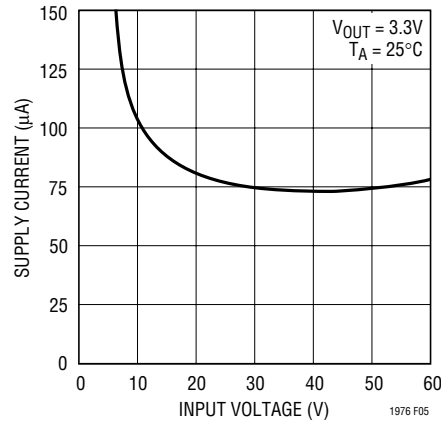

Figure 5. I_Q vs V_{IN}

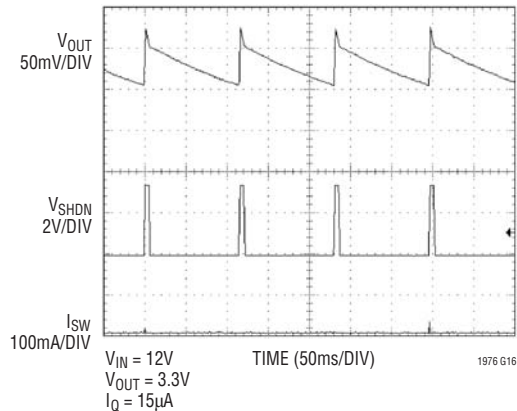

Figure 6. Burst Mode with Shutdown Pin

APPLICATIONS INFORMATION

drops to 15 μ A. The PG pin will be active low during the “on” portion of the SHDN waveform due to the C_T capacitor discharge when SHDN is taken low. See the Power Good section for further information.

CATCH DIODE

The catch diode carries load current during the SW off time. The average diode current is therefore dependent on the switch duty cycle. At high input to output voltage ratios the diode conducts most of the time. As the ratio approaches unity the diode conducts only a small fraction of the time. The most stressful condition for the diode is when the output is short circuited. Under this condition the diode must safely handle I_{PEAK} at maximum duty cycle.

To maximize high and low load current efficiency a fast switching diode with low forward drop and low reverse leakage should be used. Low reverse leakage is critical to maximize low current efficiency since its value over temperature can potentially exceed the magnitude of the LT1976 supply current. Low forward drop is critical for high current efficiency since the loss is proportional to forward drop.

These requirements result in the use of a Schottky type diode. DC switching losses are minimized due to its low forward voltage drop and AC behavior is benign due to its lack of a significant reverse recovery time. Schottky diodes are generally available with reverse voltage ratings of 60V and even 100V and are price competitive with other types.

Table 5. Catch Diode Selection Criteria

DIODE	LEAKAGE V _{OUT} = 3.3V		V _F AT 1A		I _Q at 125°C V _{IN} = 12V V _{OUT} = 3.3	EFFICIENCY V _{IN} = 12V V _{OUT} = 3.3V
	25°C	125°C	25°C	125°C	I _L = 0A	I _L = 1A
IR 10BQ100	0.0 μ A	59 μ A	0.72V	0.58V	125 μ A	74.1%
Diodes Inc. B260SMA	0.1 μ A	242 μ A	0.48V	0.41V	215 μ A	82.8%
Diodes Inc. B360SMB	0.2 μ A	440 μ A	0.45V	0.36V	270 μ A	83.6%
IR MBRS360TR	1 μ A	1.81mA	0.42V	0.34V	821 μ A	83.7%
IR 30BQ100	1.7 μ A	2.64mA	0.40V	0.32V	1088 μ A	84.5%

The effect of reverse leakage and forward drop on efficiency for various Schottky diodes is shown in Table 4. As can be seen these are conflicting parameters and the user must weigh the importance of each specification in choosing the best diode for the application.

The use of so-called “ultrafast” recovery diodes is generally not recommended. When operating in continuous mode, the reverse recovery time exhibited by “ultrafast” diodes will result in a slingshot type effect. The power internal switch will ramp up V_{IN} current into the diode in an attempt to get it to recover. Then, when the diode has finally turned off, some tens of nanoseconds later, the V_{SW} node voltage ramps up at an extremely high dV/dt, perhaps 5V to even 10V/ns! With real world lead inductances the V_{SW} node can easily overshoot the V_{IN} rail. This can result in poor RFI behavior and, if the overshoot is severe enough, damage the IC itself.

BOOST PIN

For most applications the boost components are a 0.33 μ F capacitor and a MMSD914 diode. The anode is typically connected to the regulated output voltage to generate a voltage approximately V_{OUT} above V_{IN} to drive the output stage (Figure 7a). However, the output stage discharges the boost capacitor during the on time of the switch. The output driver requires at least 2.5V of headroom throughout this period to keep the switch fully saturated. If the output voltage is less than 3.3V it is recommended that an alternate boost supply is used. The boost diode can be connected to the input (Figure 7b) but care must be taken to prevent the boost voltage (V_{BOOST} = V_{IN} • 2) from exceeding the BOOST pin absolute maximum rating. The additional voltage across the switch driver also increases power loss and reduces efficiency. If available, an independent supply can be used to generate the required BOOST voltage (Figure 7c). Tying BOOST to V_{IN} or an independent supply may reduce efficiency but it will reduce the minimum V_{IN} required to start-up with light loads. If the generated BOOST voltage dissipates too much power at maximum load, the BOOST voltage the LT1976 sees can be reduced by placing a Zener diode in series with the BOOST diode (Figure 7a option).

APPLICATIONS INFORMATION

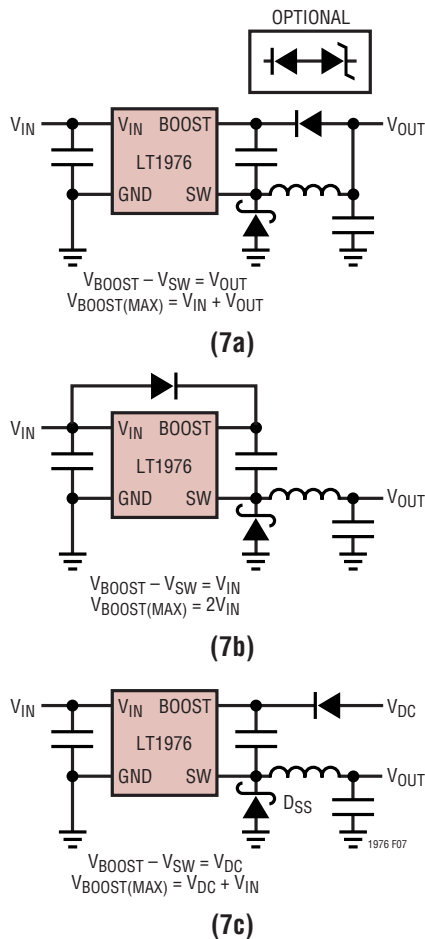

Figure 7. BOOST Pin Configurations

A 0.33μF boost capacitor is recommended for most applications. Almost any type of film or ceramic capacitor is suitable but the ESR should be <1Ω to ensure it can be fully recharged during the off time of the switch. The capacitor value is derived from worst-case conditions of 4700ns on time, 42mA boost current and 0.7V discharge ripple. The boost capacitor value could be reduced under less demanding conditions but this will not improve circuit operation or efficiency. Under low input voltage and low load conditions a higher value capacitor and Schottky boost diode will reduce discharge ripple and improve start-up and dropout operation.

SHUTDOWN FUNCTION AND UNDERVOLTAGE LOCKOUT

The SHDN pin on the LT1976 controls the operation of the IC. When the voltage on the SHDN pin is below the 1.2V shutdown threshold the LT1976 is placed in a “zero” supply current state. Driving the SHDN pin above the shutdown threshold enables normal operation. The SHDN pin has an internal sink current of 3μA.

In addition to the shutdown feature, the LT1976 has an undervoltage lockout function. When the input voltage is below 2.4V, switching will be disabled. The undervoltage lockout threshold doesn’t have any hysteresis and is mainly used to insure that all internal voltages are at the correct level before switching is enabled. If an undervoltage lockout function with hysteresis is needed to limit input current at low V_{IN} to V_{OUT} ratios refer to Figure 8 and the following:

$$V_{UVLO} = R1 \left(\frac{V_{SHDN}}{R3} + \frac{V_{SHDN}}{R2} + I_{SHDN} \right) + V_{SHDN}$$

$$V_{HYST} = \frac{V_{OUT}(R1)}{R3}$$

R1 should be chosen to minimize quiescent current during normal operation by the following equation:

$$R1 = \frac{V_{IN} - 2V}{(1.5)(I_{SHDN(MAX)})}$$

Example:

$$R1 = \frac{12 - 2}{1.5(5\mu A)} = 1.3M\Omega$$

$$R3 = \frac{5(1.3M\Omega)}{1} = 6.5M\Omega \text{ (Nearest 1\% 6.49M}\Omega\text{)}$$

$$R2 = \frac{1.3}{\frac{7 - 1.3}{1.3M\Omega} - 1\mu A - \frac{1.3}{6.49M\Omega}} = 408k \text{ (Nearest 1\% 412k)}$$

APPLICATIONS INFORMATION

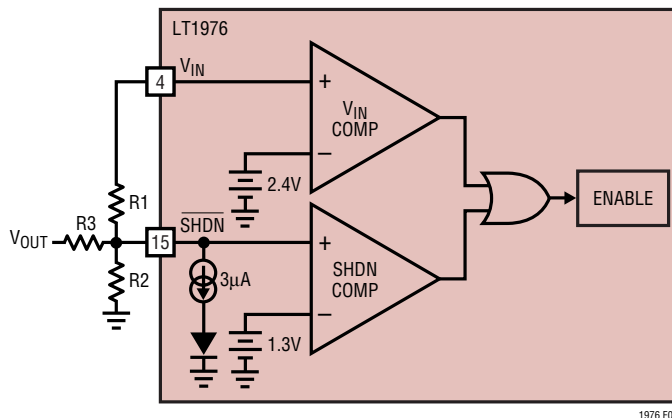

Figure 8. Undervoltage Lockout

See the Typical Performance Characteristics section for graphs of SHDN and V_{IN} currents versus input voltage.

SYNCHRONIZING

Oscillator synchronization to an external input is achieved by connecting a TTL logic-compatible square wave with a duty cycle between 20% and 80% to the LT1976 SYNC pin. The synchronizing range is equal to initial operating frequency up to 700kHz. This means that minimum practical sync frequency is equal to the worst-case high self-oscillating frequency (230kHz), not the typical operating frequency of 200kHz. Caution should be used when synchronizing above 230kHz because at higher sync frequencies the amplitude of the internal slope compensation used to prevent subharmonic switching is reduced. This type of subharmonic switching only occurs at input voltages less than twice output voltage. Higher inductor values will tend to eliminate this problem. See Frequency Compensation section for a discussion of an entirely different cause of subharmonic switching before assuming that the cause is insufficient slope compensation. Application Note 19 has more details on the theory of slope compensation.

If the FB pin voltage is below 0.9V (power-up or output short-circuit conditions) the sync function is disabled. This allows the frequency foldback to operate to avoid and hazardous conditions for the SW pin.

If the synchronization signal is present during Burst Mode operation, synchronization will occur during the burst portion of the output waveform. Synchronizing the LT1976 during Burst Mode operation may alter the natural burst frequency which can lead to jitter and increased ripple in the burst waveform.

If no synchronization is required this pin should be connected to ground.

POWER GOOD

The LT1976 contains a power good block which consists of a comparator, delay timer and active low flag that allows the user to generate a delayed signal after the power good threshold is exceeded.

Referring to Figure 2, the PGFB pin is the positive input to a comparator whose negative input is set at V_{PGFB} . When PGFB is taken above V_{PGFB} , current (I_{CSS}) is sourced into the C_T pin starting the delay period. When the voltage on the PGFB pin drops below V_{PGFB} the C_T pin is rapidly discharged resetting the delay period. The PGFB voltage is typically generated by a resistive divider from the regulated output or input supply.

The capacitor on the C_T pin determines the amount of delay time between the PGFB pin exceeding its threshold (V_{PGFB}) and the PG pin set to a high impedance state. When the PGFB pin rises above V_{PGFB} current is sourced

APPLICATIONS INFORMATION

(I_{CT}) from the C_T pin into the external capacitor. When the voltage on the external capacitor reaches an internal clamp (V_{CT}), the PG pin becomes a high impedance node. The

resultant PG delay time is given by $t = C_{CT} \cdot (V_{CT}) / (I_{CT})$. If the voltage on the PGFB pin drops below its V_{PGFB} , C_{CT} will be discharged rapidly and \overline{PG} will be active low with a 200 μ A sink capability. If the \overline{SHDN} pin is taken below its threshold during normal operation, the C_T pin will be discharged and \overline{PG} inactive, resulting in a non Power Good cycle when \overline{SHDN} is taken above its threshold. Figure 9 shows the power good operation with PGFB connected to FB and the capacitance on $C_T = 0.1\mu$ F. The PGOOD pin has a limited amount of drive capability and is susceptible to noise during start-up and Burst Mode operation. If erratic operation occurs during these conditions a small filter capacitor from the PGOOD pin to ground will ensure proper operation. Figure 10 shows several different configurations for the LT1976 Power Good circuitry.

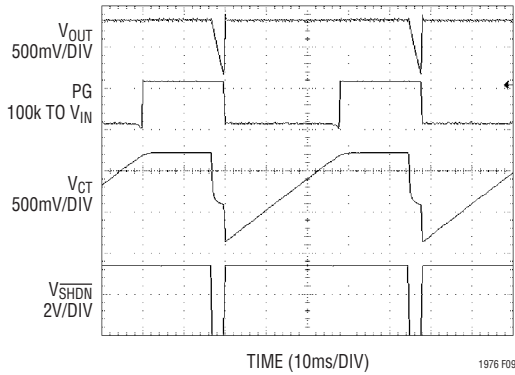
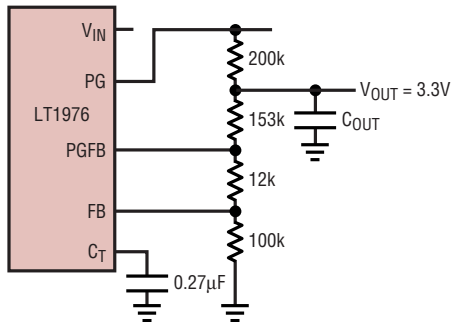
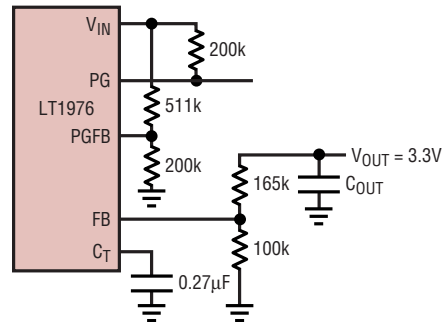

Figure 9. Power Good

PG at 80% V_{OUT} with 100ms Delay



PG at $V_{IN} > 4V$ with 100ms Delay



V_{OUT} Disconnect at 80% V_{OUT} with 100ms Delay

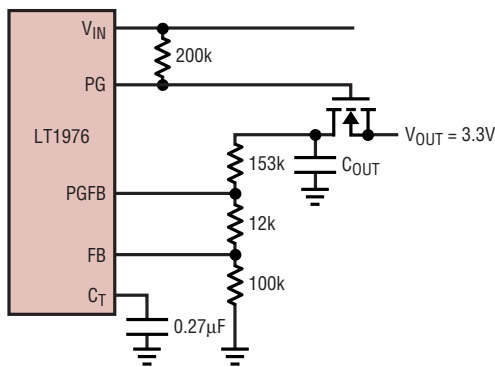

V_{OUT} Disconnect 3.3V Logic Signal with 100 μ s Delay

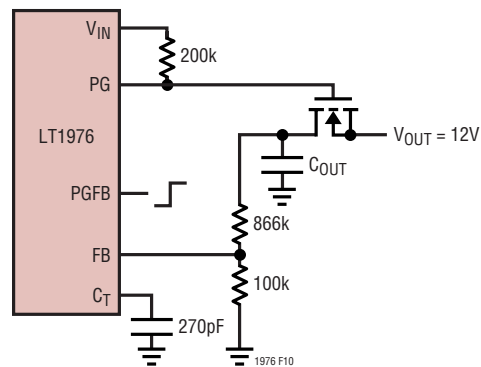

Figure 10. Power Good Circuits

APPLICATIONS INFORMATION

LAYOUT CONSIDERATIONS

As with all high frequency switchers, when considering layout, care must be taken in order to achieve optimal electrical, thermal and noise performance. For maximum efficiency switch rise and fall times are typically in the nanosecond range. To prevent noise both radiated and conducted the high speed switching current path, shown in Figure 11, must be kept as short as possible. This is implemented in the suggested layout of Figure 12. Shortening this path will also reduce the parasitic trace inductance of approximately 25nH/inch. At switch off, this parasitic inductance produces a flyback spike across the

LT1976 switch. When operating at higher currents and input voltages, with poor layout, this spike can generate voltages across the LT1976 that may exceed its absolute maximum rating. A ground plane should always be used under the switcher circuitry to prevent interplane coupling and overall noise.

The V_C and FB components should be kept as far away as possible from the switch and boost nodes. The LT1976 pinout has been designed to aid in this. The ground for these components should be separated from the switch current path. Failure to do so will result in poor stability or subharmonic like oscillation.

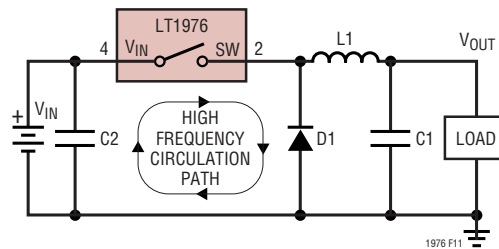

Figure 11. High Speed Switching Path

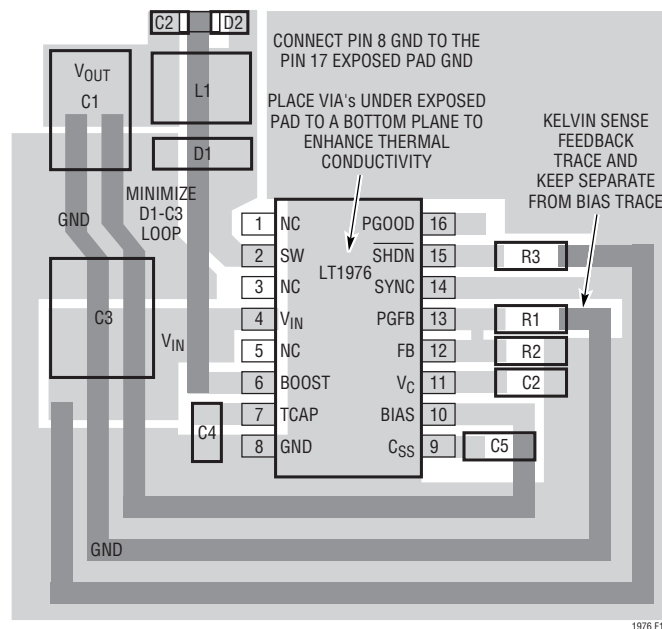

Figure 12. Suggested Layout

APPLICATIONS INFORMATION

Board layout also has a significant effect on thermal resistance. Pin 8 and the exposed die pad, Pin 17, are a continuous copper plate that runs under the LT1976 die. This is the best thermal path for heat out of the package. Reducing the thermal resistance from Pin 8 and exposed pad onto the board will reduce die temperature and increase the power capability of the LT1976. This is achieved by providing as much copper area as possible around the exposed pad. Adding multiple solder filled feedthroughs under and around this pad to an internal ground plane will also help. Similar treatment to the catch diode and coil terminations will reduce any additional heating effects.

THERMAL CALCULATIONS

Power dissipation in the LT1976 chip comes from four sources: switch DC loss, switch AC loss, boost circuit current, and input quiescent current. The following formulas show how to calculate each of these losses. These formulas assume continuous mode operation, so they should not be used for calculating efficiency at light load currents.

Switch loss:

$$P_{SW} = \frac{R_{SW}(I_{OUT})^2(V_{OUT})}{V_{IN}} + t_{EFF}(1/2)(I_{OUT})(V_{IN})(f)$$

Boost current loss:

$$P_{BOOST} = \frac{(V_{OUT})^2(I_{OUT}/36)}{V_{IN}}$$

Quiescent current loss:

$$P_Q = V_{IN}(0.0015) + V_{OUT}(0.003)$$

R_{SW} = switch resistance (≈ 0.3 when hot)

t_{EFF} = effective switch current/voltage overlap time

$(t_r + t_f + t_{IR} + t_{IF})$

$t_r = (V_{IN}/1.7)ns$

$t_f = (V_{IN}/1.2)ns$

$t_{IR} = t_{IF} = (I_{OUT}/0.05)ns$

f = switch frequency

Example: with $V_{IN} = 40V$, $V_{OUT} = 5V$ and $I_{OUT} = 1A$:

$$P_{SW} = \frac{(0.3)(1)^2(5)}{40} + (97e-9)(1/2)(1)(40)(200e3)$$

$$0.04 + 0.388 = 0.43W$$

$$P_{BOOST} = \frac{(5)^2(1/36)}{40} = 0.02W$$

$$P_Q = 40(0.0015) + 5(0.003) = 0.08W$$

Total power dissipation is:

$$P_{TOT} = 0.43 + 0.02 + 0.08 = 0.53W$$

Thermal resistance for the LT1976 package is influenced by the presence of internal or backside planes. With a full plane under the FE16 package, thermal resistance will be about $45^\circ C/W$. No plane will increase resistance to about $150^\circ C/W$. To calculate die temperature, use the proper thermal resistance number for the desired package and add in worst-case ambient temperature:

$$T_J = T_A + Q_{JA}(P_{TOT})$$

With the FE16 package ($Q_{JA} = 45^\circ C/W$) at an ambient temperature of $70^\circ C$:

$$T_J = 70 + 45(0.53) = 94^\circ C$$

If a more accurate die temperature is required, a measurement of the SYNC pin resistance to ground can be used. The SYNC pin resistance can be measured by forcing a voltage no greater than $0.25V$ at the pin and monitoring the pin current versus temperature in a controlled temperature environment. The measurement should be done with minimal device power dissipation (pull the V_C pin to ground for sleep mode) in order to calibrate the SYNC pin resistance with the ambient temperature.

APPLICATIONS INFORMATION

HIGH TEMPERATURE OPERATION

Extreme care must be taken when designing LT1976 applications to operate at high ambient temperatures. The LT1976 is designed to work at elevated temperatures but erratic operation can occur due to external components. Each passive component should be checked for absolute value and voltage ratings to ensure loop stability at temperature. Boost and Catch diode leakages, as well as increased series resistance (Table 5), will adversely affect efficiency and low quiescent current operation. Junction temperature increase in the diodes due to self heating (leakage) and power dissipation should be measured to ensure their maximum temperature specifications are not violated.

Input Voltage vs Operating Frequency Considerations

The absolute maximum input supply voltage for the LT1976 is specified at 60V. This is based solely on internal semiconductor junction breakdown effects. Due to internal power dissipation the actual maximum V_{IN} achievable in a particular application may be less than this.

A detailed theoretical basis for estimating internal power loss is given in the section Thermal Considerations. Note that AC switching loss is proportional to both operating frequency and output current. The majority of AC switching loss is also proportional to the square of input voltage.

For example, while the combination of $V_{IN} = 40V$, $V_{OUT} = 5V$ at 1A and $f_{OSC} = 200kHz$ may be easily achievable, simultaneously raising V_{IN} to 60V and f_{OSC} to 700kHz is not possible. Nevertheless, input voltage transients up to 60V can usually be accommodated, assuming the resulting increase in internal dissipation is of insufficient time duration to raise die temperature significantly.

A second consideration is controllability. A potential limitation occurs with a high step-down ratio of V_{IN} to V_{OUT} , as this requires a correspondingly narrow minimum switch on time. An approximate expression for this (assuming continuous mode operation) is given as follows:

$$t_{ON(MIN)} = V_{OUT} + V_F/V_{IN}(f_{OSC})$$

where:

V_{IN} = input voltage

V_{OUT} = output voltage

V_F = Schottky diode forward drop

f_{OSC} = switching frequency

A potential controllability problem arises if the LT1976 is called upon to produce an on time shorter than it is able to produce. Feedback loop action will lower then reduce the V_C control voltage to the point where some sort of cycle-skipping or Burst Mode behavior is exhibited.

In summary:

1. Be aware that the simultaneous requirements of high V_{IN} , high I_{OUT} and high f_{OSC} may not be achievable in practice due to internal dissipation. The Thermal Considerations section offers a basis to estimate internal power. In questionable cases a prototype supply should be built and exercised to verify acceptable operation.
2. The simultaneous requirements of high V_{IN} , low V_{OUT} and high f_{OSC} can result in an unacceptably short minimum switch on time. Cycle skipping and/or Burst Mode behavior will result although correct output voltage is usually maintained.

FREQUENCY COMPENSATION

Before starting on the theoretical analysis of frequency response the following should be remembered—the worse the board layout, the more difficult the circuit will be to stabilize. This is true of almost all high frequency analog circuits. Read the Layout Considerations section first. Common layout errors that appear as stability problems are distant placement of input decoupling capacitor and/or catch diode and connecting the V_C compensation to a ground track carrying significant switch current. In addition the theoretical analysis considers only first order non-ideal component behavior. For these reasons, it is important that a final stability check is made with production layout and components.

APPLICATIONS INFORMATION

The LT1976 uses current mode control. This alleviates many of the phase shift problems associated with the inductor. The basic regulator loop is shown in Figure 12. The LT1976 can be considered as two g_m blocks, the error amplifier and the power stage.

Figure 13 shows the overall loop response with a 330pF V_C capacitor and a typical 100 μ F tantalum output capacitor. The response is set by the following terms:

Error amplifier: DC gain is set by g_m and R_0 :

$$\text{EA Gain} = 650\mu\text{S} \cdot 1.5\text{M} = 975$$

The pole set by C_F and R_L :

$$\text{EA Pole} = 1/(2\pi \cdot 1.5\text{M} \cdot 330\text{pF}) = 322\text{Hz}$$

Unity gain frequency is set by C_F and g_m :

$$\begin{aligned} \text{EA Unity Gain Frequency} &= 650\mu\text{F}/(2\pi \cdot 330\text{pF}) \\ &= 313\text{kHz} \end{aligned}$$

Powerstage: DC gain is set by g_m and R_L (assume 10 Ω):

$$\text{PS DC Gain} = 3 \cdot 10 = 30$$

Pole set by C_{OUT} and R_L :

$$\text{PS Pole} = 1/(2\pi \cdot 100\mu\text{F} \cdot 10) = 159\text{Hz}$$

Unity gain set by C_{OUT} and g_m :

$$\text{PS Unity Gain Freq} = 3/(2\pi \cdot 100\mu\text{F}) = 4.7\text{kHz}.$$

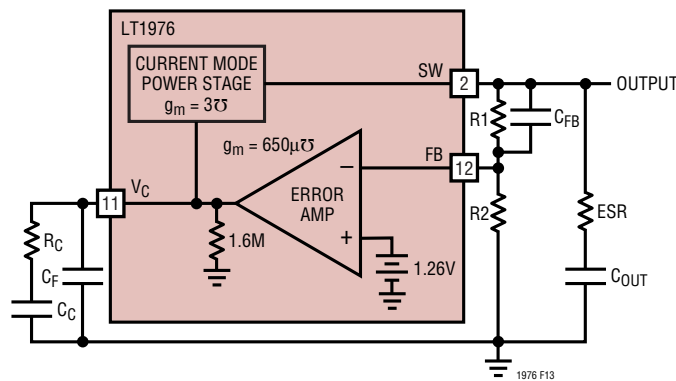

Figure 13. Model for Loop Response

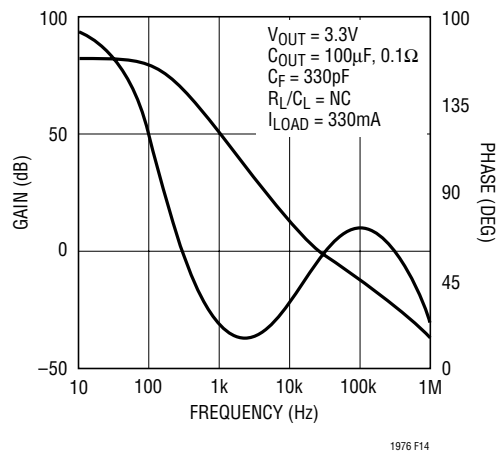

Figure 14. Overall Loop Response

APPLICATIONS INFORMATION

Tantalum output capacitor zero is set by C_{OUT} and C_{OUT} ESR

$$\text{Output Capacitor Zero} = 1/(2\pi \cdot 100\mu\text{F} \cdot 0.1) = 15.9\text{kHz}$$

The zero produced by the ESR of the tantalum output capacitor is very useful in maintaining stability. If better transient response is required, a zero can be added to the loop using a resistor (R_C) in series with the compensation capacitor. As the value of R_C is increased, transient response will generally improve but two effects limit its value. First, the combination of output capacitor ESR and a large R_C may stop loop gain rolling off altogether. Second, if the loop gain is not rolled off sufficiently at the

switching frequency output ripple will perturb the V_C pin enough to cause unstable duty cycle switching similar to subharmonic oscillation. This may not be apparent at the output. Small-signal analysis will not show this since a continuous time system is assumed. If needed, an additional capacitor (C_F) can be added to form a pole at typically one-fifth the switching frequency (if $R_C = 10\text{k}$, $C_E = 1500\text{pF}$, $C_F = 330\text{pF}$)

When checking loop stability the circuit should be operated over the application's full voltage, current and temperature range. Any transient loads should be applied and the output voltage monitored for a well-damped behavior.

PACKAGE DESCRIPTION

FE Package
16-Lead Plastic TSSOP (4.4mm)
 (Reference LTC DWG # 05-08-1663)
Exposed Pad Variation BC

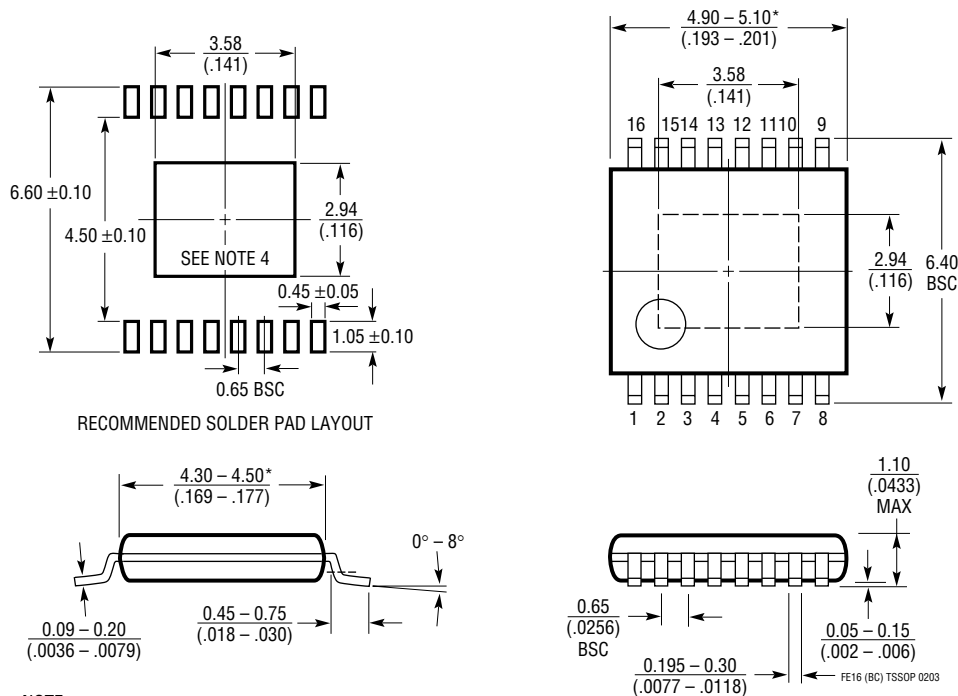

- NOTE:
1. CONTROLLING DIMENSION: MILLIMETERS
 2. DIMENSIONS ARE IN $\frac{\text{MILLIMETERS}}{\text{(INCHES)}}$
 3. DRAWING NOT TO SCALE
 4. RECOMMENDED MINIMUM PCB METAL SIZE FOR EXPOSED PAD ATTACHMENT
- *DIMENSIONS DO NOT INCLUDE MOLD FLASH. MOLD FLASH SHALL NOT EXCEED 0.150mm (.006") PER SIDE

RELATED PARTS

PART NUMBER	DESCRIPTION	COMMENTS
LT1074/LT1074HV	4.4A (I _{OUT}), 100kHz, High Efficiency Step-Down DC/DC Converters	V _{IN} : 7.3V to 45V/64V, V _{OUT(MIN)} : 2.21V, I _Q : 8.5mA, I _{SD} : 10μA, DD5/7, TO220-5/7
LT1076/LT1076HV	1.6A (I _{OUT}), 100kHz, High Efficiency Step-Down DC/DC Converters	V _{IN} : 7.3V to 45V/64V, V _{OUT(MIN)} : 2.21V, I _Q : 8.5mA, I _{SD} : 10μA, DD5/7, TO220-5/7
LT1676	60V, 440mA (I _{OUT}), 100kHz, High Efficiency Step-Down DC/DC Converter	V _{IN} : 7.4V to 60V, V _{OUT(MIN)} : 1.24V, I _Q : 3.2mA, I _{SD} : 2.5μA, S8
LT1765	25V, 3A (I _{OUT}), 1.25MHz, High Efficiency Step-Down DC/DC Converter	V _{IN} : 3V to 25V, V _{OUT(MIN)} : 1.20V, I _Q : 1mA, I _{SD} : 15μA, SO-8, TSSOP16E
LT1766	60V, 1.2A (I _{OUT}), 200kHz, High Efficiency Step-Down DC/DC Converter	V _{IN} : 5.5V to 60V, V _{OUT(MIN)} : 1.20V, I _Q : 2.5mA, I _{SD} : 25μA, TSSOP16/E
LT1767	25V, 1.5A (I _{OUT}), 1.25MHz, High Efficiency Step-Down DC/DC Converter	V _{IN} : 3V to 25V, V _{OUT(MIN)} : 1.20V, I _Q : 1mA, I _{SD} : 6μA, MS8/E
LT1776	40V, 550mA (I _{OUT}), 200kHz, High Efficiency Step-Down DC/DC Converter	V _{IN} : 7.4V to 40V, V _{OUT(MIN)} : 1.24V, I _Q : 3.2mA, I _{SD} : 30μA, N8, S8
LTC®1875	1.5A (I _{OUT}), 550kHz, Synchronous Step-Down DC/DC Converter	V _{IN} : 2.7V to 6V, V _{OUT(MIN)} : 0.8V, I _Q : 15μA, I _{SD} : <1μA, TSSOP16
LT1940	Dual 1.2A (I _{OUT}), 1.1MHz, High Efficiency Step-Down DC/DC Converter	V _{IN} : 3V to 25V, V _{OUT(MIN)} : 1.2V, I _Q : 3.8mA, MS10
LT1956	60V, 1.2A (I _{OUT}), 500kHz, High Efficiency Step-Down DC/DC Converter	V _{IN} : 5.5V to 60V, V _{OUT(MIN)} : 1.20V, I _Q : 2.5mA, I _{SD} : 25μA, TSSOP16/E
LT3010	80V, 50mA, Low Noise Linear Regulator	V _{IN} : 1.5V to 80V, V _{OUT(MIN)} : 1.28V, I _Q : 30μA, I _{SD} : <1μA, MS8E
LTC3407	Dual 600mA (I _{OUT}), 1.5MHz, High Efficiency Step-Down DC/DC Converter	V _{IN} : 2.5V to 5.5V, V _{OUT(MIN)} : 0.6V, I _Q : 40μA MS10
LTC3412	2.5A (I _{OUT}), 4MHz, Synchronous Step-Down DC/DC Converter	V _{IN} : 2.5V to 5.5V, V _{OUT(MIN)} : 0.8V, I _Q : 60μA, I _{SD} : <1μA, TSSOP16E
LTC3414	4A (I _{OUT}), 4MHz, Synchronous Step-Down DC/DC Converter	V _{IN} : 2.25V to 5.5V, V _{OUT(MIN)} : 0.8V, I _Q : 64μA, I _{SD} : <1μA, TSSOP20E
LT3430	60V, 2.5A (I _{OUT}), 200kHz, High Efficiency Step-Down DC/DC Converter	V _{IN} : 5.5V to 60V, V _{OUT(MIN)} : 1.20V, I _Q : 2.5mA, I _{SD} : 30μA, TSSOP16E
LT3431	60V, 2.5A (I _{OUT}), 500kHz, High Efficiency Step-Down DC/DC Converter	V _{IN} : 5.5V to 60V, V _{OUT(MIN)} : 1.20V, I _Q : 2.5mA, I _{SD} : 30μA, TSSOP16E
LT3433	60V, 400mA (I _{OUT}), 200kHz, Buck-Boost DC/DC Converter	V _{IN} : 5V to 60V, V _{OUT} : 3.3V to 20V, I _Q : 100μA, TSSOP-16E
LT3434	60V, 3A, 200kHz Step-Down Switching Regulator with 100μA Quiescent Current	V _{IN} : 3.3V to 60V, V _{OUT(MIN)} : 1.25V, I _Q : 100μA, I _{SD} : <1μA, TSSOP-16E
LTC3727/LTC3727-1	36V, 500kHz, High Efficiency Step-Down DC/DC Controllers	V _{IN} : 4V to 36V, V _{OUT(MIN)} : 0.8V, I _Q : 670μA, I _{SD} : 20μA, QFN-32, SSOP-28