

# Digital Panel Meters & Counters

- ▶ For process control, automation & laboratory uses
- ▶ Current, Voltage, Temperature, Frequency, Counts, etc.
- ▶ High Accuracy, Class 0,01 to 1
- ▶ High Resolution, 2000 to 40000 counts (3½ to 4¾ digits)
- ▶ LED or LCD Displays
- ▶ DIN-standard panel mounting cases



# Digital Panel Meters - Introduction

M&W Digital Panel Meters (DPMs) and Counters provide cost-effective for virtually all switchboard, instrument, laboratory and process control applications. The family offers specifications from simple digital indicators to fully programmable 'multi-function' indicator/controller models with powerful interface facilities.

Using a modular construction enables these DPMs to offer optional features such as set-point limits with switched digital or relay outputs and analogue, serial or parallel BCD data outputs. The analogue, digital and relay outputs enable simple, cost-effective, automation control and interface functions.

Models with serial or BCD output facilities can communicate with PCs or PLCs for use in more sophisticated remote control or data-acquisition system applications.

DPM versions are available for all measuring input signals: DC or AC voltage and current, thermocouples or Pt 100 sensors and resistance measurement. Some models also feature extensive non-linear and 'user defined' scaling facilities.

Their high quality construction uses DIN 43700 standard case sizes having standard 48 x 96 mm or 'low-profile' 24 x 96 mm bezel sizes. The standard display format uses red LEDs, with up to five digits for high-resolution applications.

Large digits, up to 20 mm in height, are available, as well as LCD or green LED display options for some models.

Power supply options cover all standard DC or AC requirements and some units feature a wide-range 'universal' DC/AC power supply.

In short, M&W DPMs offer comprehensive and competitively priced solutions for all modern applications.

	DPM 38/75-2000		DPM 24/48-2000		DPM 24/48-2000		DPM 48/96-2000		DPM 24/96-2000		DPM 24/96-2000		DPM 24/96-2000		DPM 24/96-2000		DPM 48/96-2000		DPM 48/96-2000		DPM 48/96-2000		DPM 48/96-2000		DPM 48/96-2000		DPM 48/96-2000		DPM 24/96-10,000		DPM 24/96-10,000		DPM 48/96-10,000		DPM 48/96-10,000		DPM 24/96-40,000		DPM 48/96-40,000		DPM 48/96-40,000		DPM 48/96-40,000	
Version	M	D	F	H	M	D	F	S	SN	M	T	F	AC	A	B	C	S	N	N	MF	P	P	Z	Z	MF	MF	R2	E1	E2															
Page number	4	6	6	8	10	12	12	14	16	18	20	20	20	20	20	20	22	24	24	28	30	30	36	36	40	40	40	40	40															
<b>Mechanical data</b>																																												
Bezel size/mm	75x38	48x24	48x24	96x48	96x24	96x24	96x24	96x24	96x24	96x48	96x48	96x48	96x48	96x48	96x48	96x48	96x48	96x48	96x48	96x24	96x24	96x48	96x24	96x48	96x24	96x48	96x48	96x48	96x48	96x48	96x48	96x48	96x48	96x48	96x48	96x48	96x48	96x48						
Panel cut-out/mm	73.2x36	45x22.2	45x22.2	92x43.5	92x22.2	92x22.2	92x22.2	92x22.2	92x22.2	92x43.5	92x43.5	92x43.5	92x43.5	92x43.5	92x43.5	92x43.5	92x45.5	92x43.5	92x43.5	91x22.5	92x22.2	92x45.5	92x22.2	92x45.5	92x22.2	92x45.5	92x22.2	92x45.5	92x45.5	92x45.5	92x45.5	92x45.5	92x45.5	92x45.5	92x45.5	92x45.5	92x45.5	92x45.5	92x45.5					
Overall depth/mm	41	69	69	61	72	72	72	72	143	138	138	138	138	138	138	143	138	138	138	194	143	143	143	143	143	143	143	143	143	143	143	143	143	143	143	143	143	143	143	143				
<b>Display</b>																																												
LED red/green	•/•	•/•	•/•		•/•	•/•	•/•	•/•	•/•	•/•	•/•	•/•	•/•	•/•	•/•	•/•	•/•	•/•	•/•	•/•	•/•	•/•	•/•	•/•	•/•	•/•	•/•	•/•	•/•	•/•	•/•	•/•	•/•	•/•	•/•	•/•	•/•	•/•	•/•	•/•				
LCD	•			•																																								
2000 counts (3 1/2)	•	•	•	•	•	•	•	•	•	•	•	•	•	•	•	•	•	•	•	•	•	•	•	•	•	•	•	•	•	•	•	•	•	•	•	•	•	•	•	•				
10,000 counts (4)																																												
20,000 counts (4 1/2)																																												
40,000 counts (4 3/4)																																												
Decimal point	•	•	•	•	•	•	•	•	•	•	•	•	•	•	•	•	•	•	•	•	•	•	•	•	•	•	•	•	•	•	•	•	•	•	•	•	•	•	•	•				
<b>Inputs</b>																																												
Plug-in cards																																												
No. of ranges	1	4	3	1	1	4	4	9	9	1	4	4	3	3	2	2	9	1	1	1	1 or 2	1 or 2	1 or 2	1 or 2	36	36	36	36	36															
Selectable by		DIP-switch	DIP-switch			Jumper	Jumper	Jumper	Jumper		DIP-switch	Input choice	DIP-switch	Input choice	Input choice	Input choice	Jumper	Plug-in card	Plug-in card	Plug-in card																								
Programmable																					Buttons, Software	Buttons, Software	Buttons, Software	Buttons, Software	Buttons, Software	Buttons, Software	Buttons, Software	Buttons, Software	Buttons, Software	Buttons, Software	Buttons, Software	Buttons, Software	Buttons, Software	Buttons, Software	Buttons, Software	Buttons, Software	Buttons, Software	Buttons, Software	Buttons, Software					
<b>Measuring ranges</b>																																												
V or I DC	•	•	V only	4-20mA	•	•	V only	•	•	•		V only		mA only	4-20mA	mV only	•	•	•	•	•	•	•	•	•	•	•	•	•	•	•	•	•	•	•	•	•	•	•					
V or I AC																																												
V or I AC-RMS																																												
Thermocouple sensor	•																																											
Pt 100 sensor	•																																											
Frequency																																												
Counter input																																												
Time interval																																												
<b>Outputs</b>																																												
Analogue output																																												
Open collectors																																												
Relays																																												
BCD 5 V not isolated																																												
BCD 5 V isolated																																												
Interface RS																																												
Power supply options																																												
5 V DC not isolated	•	isolated	isolated	Option	•	•	•	•	•	•	•	•	•	•	•	•	•	•	•	•	•	•	•	•	•	•	•	•	•	•	•	•	•	•	•	•	•	•	•	•				
24 V DC isolated		•	•		•	•	•	•	•	•	•	•	•	•	•	•	•	•	•	•	•	•	•	•	•	•	•	•	•	•	•	•	•	•	•	•	•	•	•	•	•			
19 .. 36 V DC																																												
24 V AC																																												
115 V AC																																												
230 V AC																																												
Wide range 19 .. 36 V DC u. 115/230 V AC																																												
<b>Extra functions</b>																																												
Display brightness																																												
Memory																																												
Reading HOLD	•			Option	Option	Option	Option	Option		Option	Option	Option		Option	Option	Option	Option	•	•	•	•	•	•	•	•	•	•	•	•	•	•	•	•	•	•	•	•	•	•	•				
DATA-LOGGING																																												

Please contact us

# DPM 38/75-2000 M



- ▶ Digital replacement for analogue instruments
- ▶ LCD or LED display
- ▶ Thermocouple and Pt 100 sensor options
- ▶ Zero offset e.g. to display
- ▶ 4 ... 20 mA

Compact digital display unit in a rectangular 75 mm x 38 mm housing with a small overall depth for replacing analogue display instruments. Features a wide choice of measuring ranges, including temperature sensors, suppressed zero and resistance, with a display HOLD facility. Only requires 5 V DC auxiliary power supply.

<b>Display</b>	Display range Decimal point selection Negative display indication Digit height Display type Overload indication Setting time	1999 via solder link " " 14 mm approx. / 7-segment digits LED or LCD (reflective) last 3 digits blank < 1 s
<b>Measuring ranges</b>	Direct voltage Zero offset (suppression) Input impedance Overload Direct current  Voltage drop Overload Resistance 2L Pt 100 2L, 4L Sensor current Thermocouple sensors	0 ... 200 mV to 0 ... 200 V up to 50 % of full scale 1 MΩ approx. up to 500 %, but limited to 300 V 0 ... 0.2 mA to 0 ... 200 mA or 4 ... 20 mA  200 mV approx. 2 times 20 Ω ... 2 kΩ -200 °C ... 200 °C, or 850 °C 2 mA approx. Fe-CuNi -20 °C ... 700 °C NiCr-Ni -10 °C ... 1200 °C PtRh-Pt 500 °C ... 1700 °C
<b>Accuracy</b>	Measuring accuracy  Temperature coefficient zero point drift Additional error  Suppression	0.2 % + 1 digit, plus 0.1 % + 1 digit (for zero point suppression) 100 ppm/°C, plus 100 ppm/°C Fe-CuNi 0.3 % NiCr-Ni 0.5 % PtRh-Pt 0.5 % Series mode rejection > 40 dB Common mode rejection > 80 dB

<b>Digital inputs</b>	HOLD Segment test	"0" "0"
<b>Power supply</b>	Direct voltage common mode voltage power consumption LED power consumption LCD	5 V ± 5 % not isolated - 0.5 V ... 1.5 V max. 200 mA approx. 3 mA approx.
<b>Environmental conditions</b>	Operating temperature Storage temperature Protection class front (not LCD) Climatic class Safety class Device safety EMC immunity EMC radiated interference	0 ... 50 °C - 20 ... 70 °C IP 20 to IEC EN 60 529 IP 50 Class 2 VDE/DIN 3540 II to IEC 348 / VDE 0411 to IEC EN 61 010 DIN EN 61 000-4-1 to 4 DIN EN 50 081 class B
<b>Dimensions and weights</b>	Bezel size Panel cut-out Overall depth  Weight	75 mm x 38 mm 73.2+0.5 mm x 36+0.5 mm 41 mm or < 70 mm with protective cover for options 65 g approx.
<b>Sundry</b>	Connections	Multi-pin connector (solder connection)

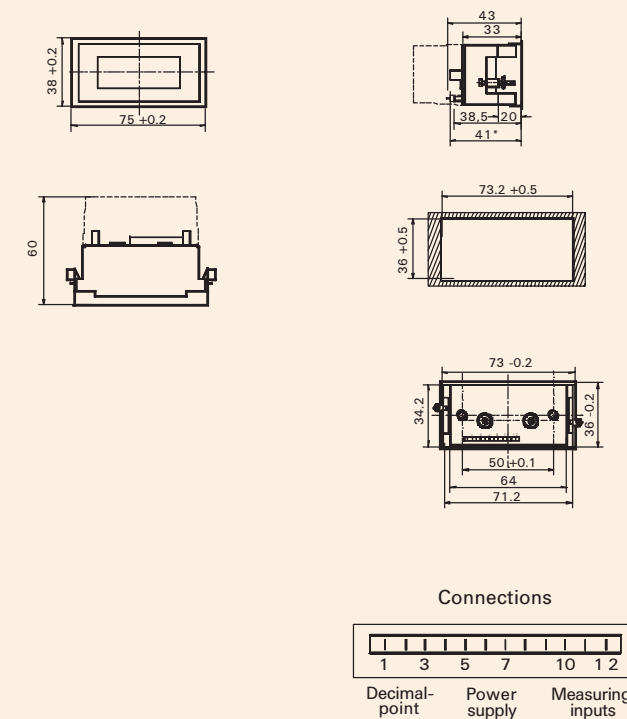

<b>Order details</b>		Example
Model :	.....	DPM 38/75-2000 M
Measuring input :	.....	- 2 ... + 8 V
Display :	.....	2.0 ... 12.0
Display caption :	.....	pH
Options :	.....	
Supply voltage:	.....	

# DPM 24/48-2000 D

# DPM 24/48-2000 F



- ▶ Front bezel size 48 x 24 mm
- ▶ Low power LED display
- ▶ Standard measuring ranges, inc. 4 ... 20 mA
- ▶ 'Snap-in' panel mounting

Compact digital display units in a 48 mm x 24 mm DIN-standard snap-in housing. The units are suitable for connecting standard current and voltage signals, including 4 mA ... 20 mA. The low power consumption and small overall size of these DPMs suits high-density panel applications.

<b>Display</b>	Display range Decimal point position Negative input indication Digit height Overload indication Setting time	1999 programmable, settable by DIP switch "m" 10 mm / 7-segment digits Last 3 digits blank < 1 s (0...99 %)
<b>Measuring ranges</b>	Direct voltage (Input current < 100 µA)  Direct current (Voltage drop < 200 mV)  Measuring accuracy Temperature coefficient zero point drift Interference voltage suppression Range adjustment span	Version D      Version F 0 ... 10 V      0 ... 0.2 V 0 ... 2 V 0 ... 20 V  0 ... 1 mA 0 ... 10 mA 4 ... 20 mA  < 0.2 % + 1 digit 100 ppm/°C, plus 200 ppm/°C > 40 dB from 10% to 100% of range
<b>Power supply</b>	24 V DC Optional	21 ... 30 V DC, 50 mA approx. 5 V DC ± 5 % , 150 mA approx.
<b>Environmental conditions</b>	Operating temperature Storage temperature Protection class front Climatic class Safety class Device safety EMC immunity EMC radiated interference	0 ... 50 °C - 40 ... 80 °C IP 20 to IEC EN 60 529 IP 50 (IP 54 on request) Class 2 VDE/DIN 3540 II to IEC 348 / VDE 0411 to IEC EN 61 010 DIN EN 61 000-4-1 to 4 DIN EN 50 081 class B

<b>Dimensions and weights</b>	Bezel size Panel cut-out Overall depth Weight	48 mm x 24 mm DIN 43 718 45 + 0.6 mm x 22.2 + 0.3 mm 69 mm < 50 g
<b>Sundry</b>	Connections	direct screw terminals
<b>Order details</b>	Type : Measuring input : Display : Display caption : Options : Supply voltage :	Example DPM 24/48-2000 D 0 ... 20 mA 0 ... 12.00 pH 24 V DC

# DPM 48/96-2000 H



- ▶ Can be self-powered in 4 ... 20 mA loop applications
- ▶ Optional 5V auxiliary power supply
- ▶ LCD display
- ▶ Overall depth only 61 mm

Low power LCD digital display unit suitable for direct connection in 4 ... 20 mA loop applications. 96 mm x 48 mm DIN-standard housing. The zero indication (with 4 mA input) and full scale (with 20 mA input) are re-settable by potentiometers. An input is available for the optional display HOLD function.

<b>Display</b>	Display range Decimal point position Negative display indication Digit height Display type Overload indication Setting time	1999 factory set " 14 mm approx. / 7-segment digits LCD (reflective) last 3 digits blank < 1 s
<b>Measuring range</b>	Input Display range Zero offset Zero point display Full scale display Accuracy Temperature coefficient zero point drift	4 ... 20 mA must be greater than 200 from -1000 to 1000 ± 5 % potentiometer adjustment ± 5 % potentiometer adjustment < 0.2 % + 1 digit 100 ppm/°C, plus 100 ppm/°C
<b>Digital input</b>	HOLD (optional)	„0“
<b>Power supply</b>	Normally none required voltage drop Option common mode voltage	Self-powered from 4 ... 20 mA loop, 5 V approx. + 5 V DC ± 5 % not isolated, none (input must be isolated from power supply)
<b>Environmental conditions</b>	Operating temperature Storage temperature Protection class front Climatic class Safety class Device safety EMC immunity EMC radiated interference	0 ... 50 °C - 20 ... 50 °C IP 20 to IEC EN 60 529 IP 50 Class 2 VDE/DIN 3540 II to IEC 348 / VDE 0411 to IEC EN 61 010 DIN EN 61 000-4-1 to 4 DIN EN 50 081 class B

<b>Dimensions and weights</b>	Bezel size Panel cut-out Overall depth Weight	96 mm x 48 mm 92+0.8 mm x 43.5+0.6 mm 61 mm (including fixing screws) 65 g approx.
<b>Sundry</b>	Connections	direct screw terminals
<b>Order details</b>	Model : Measuring input: Display : Display caption : Options :	Example DPM 48/96-2000 H 4 mA ... 20 mA 2.0 ... 12.0 pH HOLD

# DPM 24/96-2000 M



- ▶ **Factory pre-set for one measuring range**
- ▶ **Current or voltage input range**
- ▶ **Full-scale value adjustable by 10% approx.**
- ▶ **230 V AC power supply option**
- ▶ **Overall depth only 72 mm**

Low profile digital display unit in 96 mm x 24 mm DIN-standard housing with small overall depth. The measuring range is factory pre-set, but is adjustable  $\pm 5\%$  of the pre-set value by the user, which enables simple and rapid installation of these DPMs. Although the housing is only 24 mm high, the choice of power supplies includes 230 V AC mains.

<b>Display</b>	Display range Decimal point position Negative input indication Digit height Overload indication Setting time	1999 selectable by rear jumper position " " 14 mm / 7-segment digits last 3 digits blank < 1 s (0...99 %)
<b>Measuring ranges</b>	Direct voltage (Input current < 300 $\mu$ A) Direct current (Voltage drop < 600 mV) Accuracy Temperature coefficient zero point drift	60 mV ..... 300 V  1 mA ..... 200 mA  < 0.2 % + 1 digit 100 ppm/°C, plus 200 ppm/°C
<b>Options</b>	Brightness adjustment Zero suppression HOLD input	
<b>Digital input</b>	HOLD (option)	„0“
<b>Power supply</b>	Direct voltage DC common mode voltage  Alternating voltage AC	5 V $\pm 5\%$ , - 0.5 V ... 1.5 V max. 21...30 V $\pm 15\%$ 230 V +10 % - 15 %  0.6 W not isolated  4 W approx. 1.3 W approx.
<b>Environmental conditions</b>	Operating temperature Storage temperature Protection class front Climatic class Safety class Device safety EMC immunity EMC radiated interference	0 ... 50 °C - 40 ... 80 °C IP 20 to IEC EN 60 529 IP 54 (IP 65 on request) Class 2 VDE/DIN 3540 II to IEC 348 / VDE 0411 to IEC EN 61 010 DIN EN 61 000-4-1 to 4 DIN EN 50 081 class B

<b>Dimensions and weights</b>	Bezel size Panel cut-out Overall depth Weight	96 mm x 24 mm to DIN 43 718 92+0.8 mm x 22.2+0.3 mm 72 mm 210 g approx. (5 V DC version 90 g)
<b>Sundry</b>	Connections	Plug-in screw terminal blocks
<p style="text-align: center;"><b>Connections</b></p> <p style="text-align: center;">Power supply    Decimal point    Measuring inputs</p>		
<b>Order details</b>	Model : Measuring input : Display : Display caption : Options : Supply voltage :	Example  DPM 24/96-2000 M 0 ... 200 V 500 ... 1500 kN  230 V AC

# DPM 24/96-2000 D

# DPM 24/96-2000 F



- ▶ Factory pre-set with several measuring ranges
- ▶ Measuring ranges selectable using jumpers
- ▶ Zero point and final value adjustable (inc. 4 ... 20 mA)
- ▶ 230 V AC power supply option
- ▶ Overall depth only 72 mm

Low-profile digital display units in a 96 mm x 24 mm DIN-standard housing with small overall depth. The two versions offer a choice of several factory pre-set measuring ranges, with user adjustments available for the zero and full scale values. This enables these DPMs to be stocked by the customer for simple configuration and rapid installation when required. Although the housing is only 24 mm high, the choice of power supplies includes 230 V AC mains.

<b>Display</b>	Display range Decimal point position Negative display indication Digit height Overload indication Setting time	1999 selectable by rear jumper position "." 14 mm / 7-segment digits last 3 digits blank < 1 s																
<b>Measuring ranges</b>	Direct voltage (Input current < 300 µA)  Direct current (Voltage drop < 600 mV)  Range adjustment span Accuracy Temperature coefficient zero point drift	<table border="0"> <tr> <td>Version D</td> <td>Version F</td> </tr> <tr> <td>0 ... 10 V</td> <td>0 ... 0.2 V</td> </tr> <tr> <td></td> <td>0 ... 2 V</td> </tr> <tr> <td></td> <td>0 ... 20 V</td> </tr> <tr> <td></td> <td>0 ... 200 V</td> </tr> <tr> <td>0 ... 1 mA</td> <td></td> </tr> <tr> <td>0 ... 20 mA</td> <td></td> </tr> <tr> <td>4 ... 20 mA</td> <td></td> </tr> </table> from 10% to 100% of range < 0.2 % + 1 digit 100 ppm/°C, plus 100 ppm/°C	Version D	Version F	0 ... 10 V	0 ... 0.2 V		0 ... 2 V		0 ... 20 V		0 ... 200 V	0 ... 1 mA		0 ... 20 mA		4 ... 20 mA	
Version D	Version F																	
0 ... 10 V	0 ... 0.2 V																	
	0 ... 2 V																	
	0 ... 20 V																	
	0 ... 200 V																	
0 ... 1 mA																		
0 ... 20 mA																		
4 ... 20 mA																		
<b>Options</b>	Brightness adjustment Zero offset HOLD input																	
<b>Digital input</b>	HOLD (option)	„0“																
<b>Power supply</b>	Direct voltage DC common mode voltage  Alternating voltage AC	<table border="0"> <tr> <td>5 V ± 5 %</td> <td>0.6 W not isolated</td> </tr> <tr> <td>- 0.5 V ... 1.5 V max.</td> <td></td> </tr> <tr> <td>21...30 V ± 15 %</td> <td>4 W approx.</td> </tr> <tr> <td>230 V +10 % - 15 %</td> <td>1.3 W approx.</td> </tr> </table>	5 V ± 5 %	0.6 W not isolated	- 0.5 V ... 1.5 V max.		21...30 V ± 15 %	4 W approx.	230 V +10 % - 15 %	1.3 W approx.								
5 V ± 5 %	0.6 W not isolated																	
- 0.5 V ... 1.5 V max.																		
21...30 V ± 15 %	4 W approx.																	
230 V +10 % - 15 %	1.3 W approx.																	
<b>Environmental conditions</b>	Operating temperature Storage temperature Protection class front Climatic class Safety class Device safety EMC immunity EMC radiated interference	0 ... 50 °C - 40 ... 80 °C IP 20 to IEC EN 60 529 IP54 (IP 65 on request) Class 2 VDE/DIN 3540 II to IEC 348 / VDE 0411 to IEC EN 61 010 DIN EN 61 000-4-1 to 4 DIN EN 50 081 class B																

<b>Dimensions and weights</b>	Front bezel size Panel cut-out Overall depth Weight	96 mm x 24 mm to DIN 43 718 92+0.8 mm x 22.2+0.3 mm 72 mm 210 g approx. (5 V DC version 90 g)
<b>Sundry</b>	Connection	plug-in screw terminal block
<b>Order details</b>	Model : Measuring input : Display : Display caption : Options : Supply voltage :	Example  DPM 24/96-2000 D 0 ... 20 mA 0 ... 500 V  24 V DC

# DPM 24/96-2000 S



- ▶ **Factory pre-set with many measuring ranges**
- ▶ **Measuring ranges selectable using jumpers**
- ▶ **Zero point and final value adjustable (inc. 4 ... 20 mA)**
- ▶ **230 V AC power supply option**
- ▶ **Overall depth only 72 mm**

Low-profile digital display units in a 96 mm x 24 mm DIN-standard housing with small overall depth. The choice of many factory pre-set measuring ranges is included, with user adjustments available for the zero and full scale values. This enables these DPMs to be stocked by the customer for simple configuration and rapid installation when required. Although the housing is only 24 mm high, the choice of power supplies includes 230 V AC mains.

<b>Display</b>	Display range Decimal point position Negative display indication Digit height Overload indication Setting time	1999 selectable by rear jumper position "-" 14 mm / 7-segment digits last 3 digits blank < 1 s (0...99 %)	
<b>Measuring ranges</b>	Direct voltage (Input current < 300 µA)	0 ... 0.2 V 0 ... 1 V 0 ... 5 V 0 ... 25 V 0 ... 100 V 0 ... 300 V	
	Direct current (Voltage drop < 600 mV)	0 ... 1 mA 0 ... 20 mA 0 ... 200 mA	
	Range adjustment span Zero offset (suppression) Accuracy Temperature coefficient zero point drift	from 20% to 100% of range up to - 1000 < 0.2 % + 1 digit 100 ppm/°C, plus 100 ppm/°C	
<b>Options</b>	Brightness adjustment Zero point adjustment HOLD input		
<b>Digital input</b>	HOLD (option)	„0“	
<b>Power supply</b>	Direct voltage DC common mode voltage	5 V ± 5 % - 0.5 V ... 1.5 V max. 21...30 V ± 15 %	0.6 W not isolated 4 W approx.
	Alternating voltage AC	230 V +10 % - 15 %	1.3 W approx.
<b>Environmental conditions</b>	Operating temperature Storage temperature Protection class front Climatic class Safety class Device safety EMC immunity EMC radiated interference	0 ... 50 °C - 40 ... 80 °C IP 20 to IEC EN 60 529 IP54, (IP 65 on request) Class 2 VDE/DIN 3540 II to IEC 348 / VDE 0411 to IEC EN 61 010 DIN EN 61 000-4-1 to 4 DIN EN 50 081 class B	

<b>Dimensions and weights</b>	Bezel size Panel cut-out Overall depth Weight	96 mm x 24 mm to DIN 43 718 92+0.8 mm x 22.2+0.3 mm 72 mm 210 g approx. (5 V DC version 90 g)
-------------------------------	--	--

<b>Sundry</b>	Connection	plug-in screw terminal block
---------------	------------	------------------------------

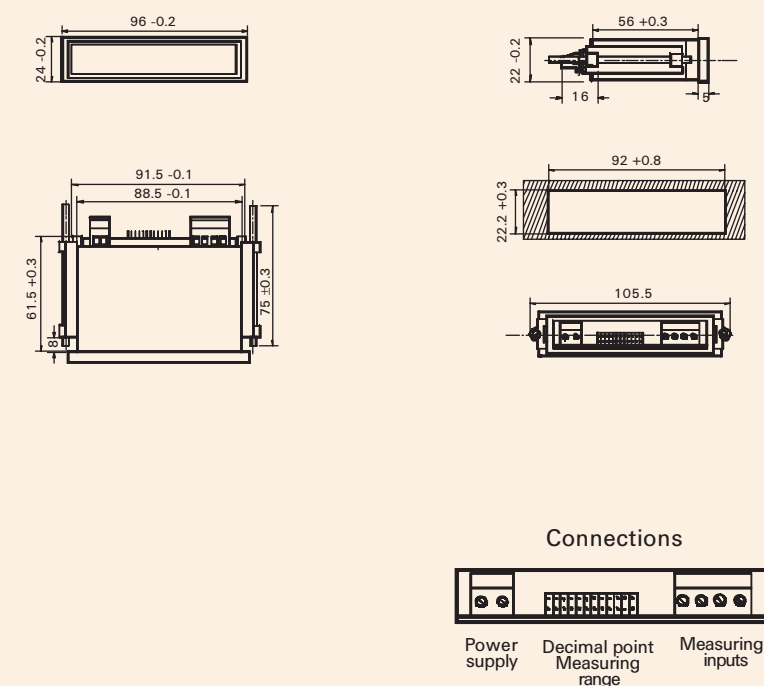

<b>Order details</b>	Model : Measuring input : Display : Display caption : Options : Supply voltage :	Example DPM 24/96-2000 S  V 24 V DC
----------------------	---	---

# DPM 24/96-2000 SN



- ▶ Factory pre-set with many measuring ranges
- ▶ Measuring ranges selectable using jumpers
- ▶ Zero point and final value adjustable (inc. 4 ... 20 mA)
- ▶ 'Wide-range' power supply

Low-profile digital display units in a 96 mm x 24 mm DIN-standard housing with small overall depth. The 'wide-range' power supply ensures problem-free connection to standard auxiliary power supplies from 24 V DC or AC to 230 V AC. Many factory pre-set measuring ranges are included, with user adjustments available for the zero and full scale values. This combination of features enables these DPMs to be stocked by the customer for simple configuration and rapid installation when required.

<b>Display</b>	Display range Decimal point position Negative display indication Digit height Overload indication Setting time	1999 selectable by rear jumper position "-" 14 mm / 7-segment digits last 3 digits blank < 1 s (0...99 %)
<b>Measuring ranges</b>	Direct voltage (Input current < 300 µA)  Direct current (Voltage drop < 600 mV)  Range adjustment span Zero offset (suppression) Accuracy Temperature coefficient zero point drift	0 ... 0.2 V 0 ... 1 V 0 ... 5 V 0 ... 25 V 0 ... 100 V 0 ... 300 V  0 ... 1 mA 0 ... 20 mA 0 ... 200 mA  from 20% to 100% of range up to - 1000 < 0.2 % + 1 digit 100 ppm/°C, plus 100 ppm/°C
<b>Options</b>	Brightness adjustment Zero point adjustment HOLD input	
<b>Power supply</b>	'Wide-range'	19.. 36 V DC/AC, 3 W approx. and 115/230 V AC, 8W approx.
<b>Environmental conditions</b>	Operating temperature Storage temperature Protection class front Climatic class Safety class Device safety EMC immunity EMC radiated interference	0 ... 50 °C - 40 ... 80 °C IP 20 to IEC EN 60 529 IP54 (IP 65 on request) Class 2 VDE/DIN 3540 II to IEC 348 / VDE 0411 to IEC EN 61 010 DIN EN 61 000-4-1 to 4 DIN EN 50 081 class B

<b>Dimensions and weights</b>	Bezel size Panel cut-out Overall depth Weight	96 mm x 24 mm to DIN 43 718 92+0.8 mm x 22.2+0.3 mm 143 mm approx. 210 g
<b>Sundry</b>	Connections	plug-in screw terminal block
<b>Order details</b>	Model : Measuring input : Display : Display caption : Options :	Example  DPM 24/96-2000 SN 100 V  V HOLD

# DPM 48/96-2000 M



- ▶ Factory pre-set for one measuring range
- ▶ Current or voltage input range
- ▶ Final value adjustable by 10 % approx.
- ▶ Bright LED display, 14 or 20 mm digit height

Standard size digital display unit in 96 mm x 48 mm DIN-standard housing. The actual measuring range is factory pre-set, but is adjustable  $\pm 5\%$  of the pre-set value by the user, which enables simple and rapid installation of these DPMs. Choice of power supplies includes 24 V DC and 115 or 230 V AC mains.

<b>Display</b>	Display range Decimal point position Negative display indication Digit height Overload indication Setting time	1999 selectable "–" 14 mm or 20 mm / 7-segment digits last 3 digits blank < 1 s (0...99 %)
<b>Measuring ranges</b>	Direct voltage (Input current < 300 $\mu$ A) Direct current (Voltage drop < 600 mV)	60 mV ..... 300 V  1 mA ..... 200 mA
<b>Accuracy</b>	Measuring accuracy Temperature coefficient zero point drift	< 0.2 % + 1 digit 100 ppm/°C, plus 200 ppm/°C
<b>Options</b>	Display brightness adjustment Zero point suppression HOLD input	
<b>Digital input</b>	HOLD (option)	„0“
<b>Power supply</b>	Direct voltage DC common mode voltage  Alternating voltage AC	5 V $\pm$ 5 %      0.6 W approx. non isolated - 0.5 V ... 1.5 V max. 21...30 V $\pm$ 15 %      4 W approx. 24 V +10 % - 15 %      4 W approx. 115 V +10 % - 15 %      4 W approx. 230 V +10 % - 15 %      4 W approx.

<b>Environmental conditions</b>	Operating temperature Storage temperature Protection class front Climatic class Safety class Device safety EMC immunity EMC radiated interference	0 ... 50 °C - 40 ... 80 °C IP 20 to IEC EN 60 529 IP 54 (IP65 on request) Class 2 VDE/DIN 3540 II to IEC 348 / VDE 0411 to IEC EN 61 010 DIN EN 61 000-4-1 to 4 DIN EN 50 081 class B
<b>Dimensions and weights</b>	Bezel size Panel cut-out Overall depth Weight	96 mm x 48 mm to DIN 43 718 92+0.8 mm x 45.5+0.6 mm 143 mm 480 g approx. (5 V DC version 140 g)

<b>Sundry</b>	Connections	Plug-in screw terminal blocks
---------------	-------------	-------------------------------

Dimensions for 20 mm digit height  
look for DPM 48/96-2000 S

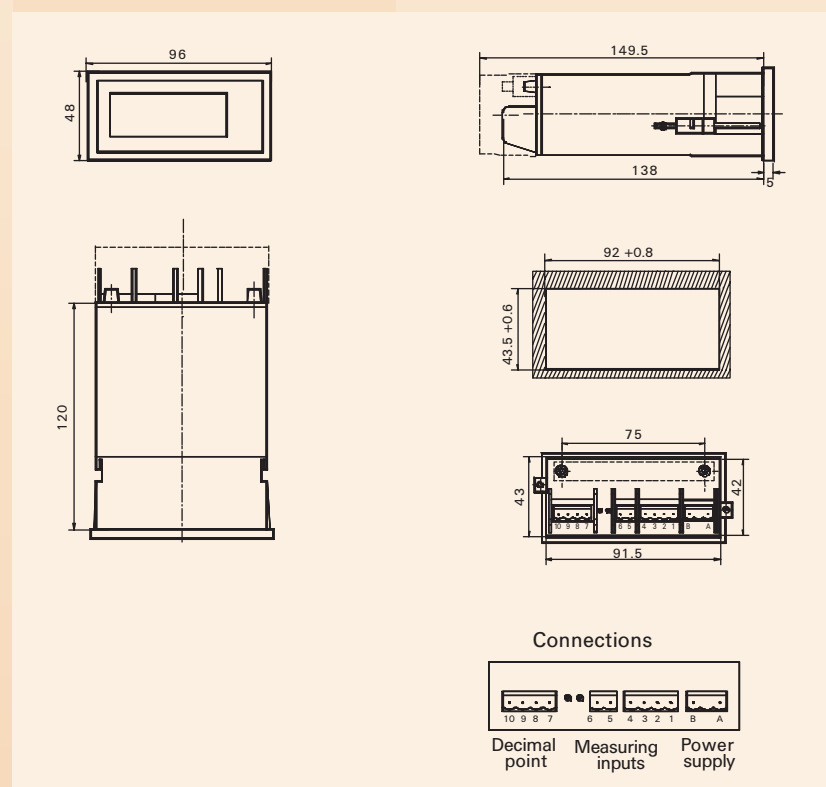

<b>Order details</b>		Example
Model :	.....	DPM 48/96-2000 M
Digit height :	.....	20 mm
Measuring input :	.....	- 2 ... + 8 V
Display :	.....	2.0 ... 12.0

# DPM 48/96-2000



- Multi-range versions
- DC or AC, Voltage or Current ranges
- Pt 100 temperature version
- Scaling adjustable over a wide range

Highly adaptable DPMs suitable for a wide range of measuring applications. Versions available for current or voltage inputs (DC and AC), or Pt 100 temperature sensors. The chosen input range is user adjustable, from 10% to 100% of the full-scale value, for simple adaptation of the digital readout to the input value. For example, the AC version can be scaled for standard 5 A secondary current transformers. 96 mm x 48 mm DIN-standard housings.

<b>Display</b>	Display range Decimal point position Negative display indication Digit height Overload indication	1999 selectable "–" 14 mm / 7-segment digits last 3 digits blank
----------------	---	--

### Measuring ranges

(Max. overload 20 % of full-scale range value)

Version	A	B	C	F	AC (50 ... 60 Hz)	T °C or °F
Voltage Input current < 300 µA			0 ... 60 mV 0 ... 150 mV	0 ... 2 V 0 ... 20 V 0 ... 200 V 0 ... 500 V	0 ... 500 V	
Current Voltage drop < 600 mV	0 ... 2 mA 0 ... 20 mA 0 ... 200 mA	0 ... 20 mA 4 ... 20 mA			0 ... 1 A 0 ... 5 A	
Pt 100 sensors						-100 ... 850°C -199.9 ... 199.9°C 2-, 3- or 4- wire DIP switch
Range selection by	Input choice	Input choice	Input choice	Input choice	DIP switch/ Input choice	

<b>Accuracy Versions A,B,C,F:</b>	Measuring accuracy DC Temperature coefficient zero point drift Range adjustment span	< 0.1 % + 1 digit 100 ppm/°C, plus 100 ppm/°C 10% to 100% of range
<b>Version AC:</b>	Measuring accuracy voltage (Input current < 500 µA) Measuring accuracy current (Voltage drop < 600 mV) Temperature coefficient zero point drift Range adjustment span	< 0.5 % + 1 digit  < 0.5 % + 1 digit 100 ppm/°C, plus 200 ppm/°C 10% to 100% of range
<b>Version T:</b>	Measuring accuracy Temperature coefficient zero point drift Range adjustment span Max allowable line resistance 2L 3L 4L	< 0.2 % + 1 digit 100 ppm/°C, plus 100 ppm/°C ± 5 % 10 Ω < 50 Ω < 50 Ω

<b>Digital input</b>	HOLD (optional)	„0“ (not available for Versions AC, or T)
----------------------	-----------------	---

<b>Power supply</b>	Direct voltage DC common mode voltage  Alternating voltage AC	5 V ± 5 % - 0.5 V ... 1.5 V max. 24 V ± 15 % 24 V +10 % -15 % 115 V +10 % -15 % 230 V +10 % -15 %	1 W max. non isolated 4 W approx. 4 W approx. 4 W approx. 4 W approx.
<b>Environmental conditions</b>	Operating temperature Storage temperature Protection class front Climatic class Safety class Device safety EMC immunity EMC radiated interference	0 ... 50 °C - 40 ... 80 °C IP 20 to IEC EN 60 529 IP50 (IP 54 on request) Class 2 to VDE/DIN 3540 II to IEC 348 / VDE 0411 to IEC EN 61 010 DIN EN 61 000-4-1 to 4 DIN EN 50 081 Class B	
<b>Dimensions and weights</b>	Bezel size Panel cut-out Overall depth Weight	96 mm x 48 mm to DIN 43 718 92+0.8 mm x 43,5+0.6 mm 138 mm 500 g approx.	
<b>Sundry</b>	Connections	Plug-in screw terminal blocks	

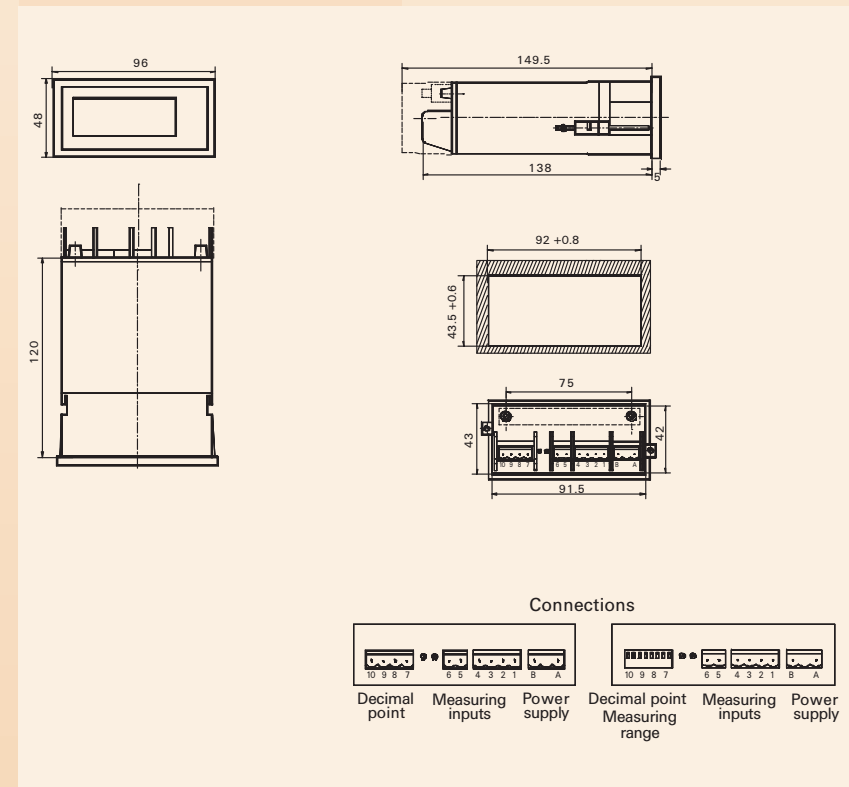

<b>Order details</b>	Model : Measuring input : Display : Display caption : Options : Supply voltage :	Example  DPM 48/96-2000 AC  A  24 V AC
----------------------	---	--

# DPM 48/96-2000 S



- ▶ Factory pre-set with many measuring ranges
- ▶ Measuring ranges selectable using jumpers
- ▶ Full-scale value adjustable
- ▶ LED, 14 mm or 20 mm high digits

The choice of many factory pre-set measuring ranges is included, with user adjustment of the full-scale value by up to 200% approx. This enables these DPMs to be stocked by the customer for simple configuration and rapid installation when required. The IP 65 protection option suits applications in adverse operating environments. 96 mm x 48 mm DIN-standard housing.

<b>Display</b>	Display range Decimal point position Negative display indication Digit height Overload indication	1999 programmable "-" 14 mm or 20 mm / 7-segment digits last 3 digits blank
<b>Measuring ranges</b> (Max. overload 20 % end of range)	Voltage (Input current < 300 µA)  Current (Voltage drop < 600 mV)	0 ... 0.2 V 0 ... 1 V 0 ... 5 V 0 ... 25 V 0 ... 100 V 0 ... 300 V 0 ... 1 mA 0 ... 20 mA 0 ... 200 mA
<b>Accuracy</b>	Measuring accuracy Temperature coefficient zero point drift	< 0.1 % + 1 digit 100 ppm/°C, plus 100 ppm/°C
<b>Options</b>	Brightness adjustment Zero point offset HOLD input	
<b>Digital input</b>	HOLD (option)	„0“
<b>Power supply</b>	Direct voltage DC common mode voltage  Alternating voltage AC	5 V ± 5 % 1 W max. approx. non isolated -0.5 ... 1.5 V max. 21...30 V ± 15 % 4 W approx. 24 V +10 % -15 % 4 W approx. 115 V +10 % -15 % 4 W approx. 230 V +10 % -15 % 4 W approx.

<b>Environmental conditions</b>	Operating temperature Storage temperature Protection class front Climatic class Safety class Device safety EMC immunity EMC radiated interference	0 ... 50 °C - 40 ... 80 °C IP 20 to IEC EN 60 529 IP54 (IP65 on request) Class 2 to VDE/DIN 3540 II to IEC 348 / VDE 0411 to IEC EN 61 010 DIN EN 61 000-4-1 to 4 DIN EN 50 081 class B
<b>Dimensions and weights</b>	Bezel size Panel cut-out Overall depth Weight	96 mm x 48 mm to DIN 43 718 92+0.8 mm x 45.5+0.6 mm 143 mm 500 g max.
<b>Sundry</b>	Connections	Plug-in screw terminal blocks

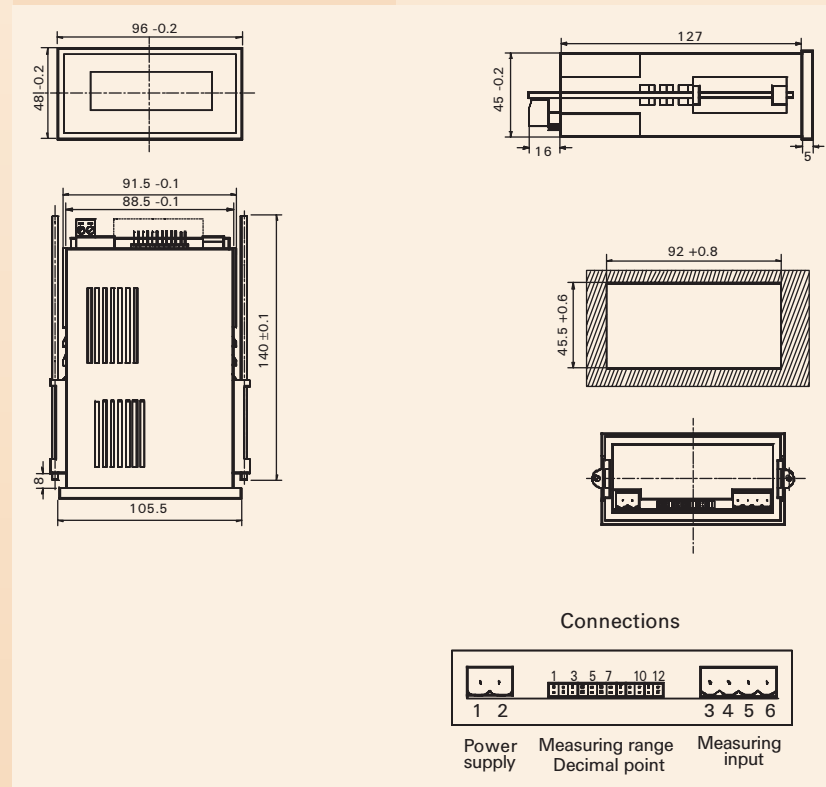

<b>Order details</b>	Model : Measuring input : Display : Display caption : Options : Supply voltage :	Example DPM 48/96-2000 S  m/s Zero point adjustment 24 V DC
----------------------	---	--

# DPM 48/96-2000 N

# DPM 48/96-20000 N



- ▶ High-accuracy 3½ - or 4½ - digit display
- ▶ Plug-in signal-conditioning input range cards
- ▶ Alarm limit and BCD output options
- ▶ Analogue output

High-performance digital instruments with a choice of 2,000 or 20,000 count display resolution. The input measuring range is set by interchangeable plug-in cards (See pages 46-47). An analogue output extends the possible applications. Optional features include an adjustable limit Alarm (only DPM 48/96-2000 N) and BCD outputs. 96 mm x 48 mm DIN-standard housing.

		48/96-2000	48/96-20,000
<b>Display</b>	Display range Decimal point position Negative display indication Digit height Overload indication	1999 selectable "–" 14 mm / 7-segment digits flashing display	19999
<b>Digital input</b>	HOLD	"0"	
<b>Measuring ranges</b>	See Plug-in Card selection (Pages 46-47)	Measuring inputs are electrically isolated from the power supply, test voltage 3 kV Analogue output is not isolated from measuring input	

<b>Accuracy</b> DPM 48/96-2000 N	Accuracy, basic unit Zero point accuracy Range drift Zero point drift	0.05 % + 1 digit < 1 digit < 50 ppm/°C < 50 ppm/°C
<b>DPM 48/96-20,000 N</b>	Accuracy, basic unit Zero point accuracy Range drift Zero point drift  Additional error  Analogue output accuracy zero point accuracy	0.01 % + 1 digit < 1 digit < 25 ppm/°C < 25 ppm/°C  See Plug-in Card Section  0 V ... 1 V 0.2 % 0.2 %
<b>Analogue output</b>	0 ... 1 V DC	(Not electrically isolated from the measuring input)
<b>Alarm Output (Optional)</b> (DPM 48/96-2000 N only)	Number of limits <b>Relay output</b> relay rating or <b>Transistor output</b>  Alarm indication Hysteresis Setting accuracy Temperature coefficient <b>Operation:</b> Limit value setting Limit value type	One 1 relay (1 change-over contact), fail-safe 250 V, 2 A max., 100 W DC/500 W AC max.  'Initiator' (DIN 19 234) electrically isolated < 1 mA at 9 V blocking > 2.2 mA at 7.7 V conductive  via front LED 0.5 % approx. < 0.5 % < 100 ppm/°C front push-button via potentiometer selectable (min, max, positive, negative)
<b>BCD-output (Option)</b>	Type Level Signals	parallel, non-isolated TTL HOLD, overflow

<b>Power supply</b>	Direct voltage DC Alternating voltage AC	21 ... 30 V 24 V +10 % -15 % 115 V+10 % -15 % 230 V+10 % -15 %	180 mA appr. 5.5 W appr. 5.5 W appr. 5.5 W appr.
<b>Environmental conditions</b>	Operating temperature Storage temperature Protection class front Climatic class Safety class Device safety EMC immunity EMC radiated interference	0 ... 50 °C - 20 ... 70 °C IP 20 to IEC EN 60 529 IP 50 (IP 54 on request) Class 2 to VDE/DIN 3540 I to IEC 348 / VDE 0411 to IEC EN 61 010 DIN EN 61 000-4-1 to 4 DIN EN 50 081 class B	
<b>Dimensions and weights</b>	Bezel size Panel cut-out Overall depth Weight	96 mm x 48 mm (DIN 43 718) 92+0.8 mm x 43.5+0.6 mm 138 mm 380 g approx.	
<b>Sundry</b>	Connections	Plug-in screw terminal blocks	

<b>Order details</b>	<p>Model : .....</p> <p>Measuring input : .....</p> <p>Display : .....</p> <p>Display caption : .....</p> <p>Options : .....</p> <p>Supply voltage : .....</p>	<p>Example</p> <p>DPM 48/96-20000 N 4 ... 20 mA 0 ... 3500 m/s 1 limit value, fail-safe 230 V AC</p>

# DPM 24/96-10.000 MF



- Full four-digit display resolution
- Plug-in signal-conditioning input range cards
- Two relay switching Alarm limit outputs
- Analogue output

Compact digital indicator/controller unit with two alarm limits and an analogue output. The plug-in signal-conditioning cards enable different thermocouple sensors or standard signals to be connected (see Plug-in Card Selection pages 46-47). A digital REBUS interface is also built-in. 96 mm x 24 mm DIN-standard housing.

<b>Display</b>	Display range Decimal point position Negative input indication Digit height Overload indication Accuracy	9999, programmable programmable or selectable "- (to -1999) 14 mm / 7-segment digits flashing display < 0.2 % + 1 digit
<b>Measuring ranges</b>	<b>See Plug-in Cards selection (Pages 46-47)</b> Additional error	Measuring inputs are electrically isolated from the power supply, test voltage 1.5 kV See Plug-in Card Section
<b>Analogue output</b>	Level  accuracy zero point accuracy	0 ... 1 V DC (Not electrically isolated from the measuring input) 0.2 % 0.2 %
<b>Alarm output (Option)</b>	Number of limits Output relay ratings Indication Hysteresis Setting accuracy	Two 2 relays (1 change-over, 1 normally closed) 250 V, 2 A max. via two front LEDs 0.5 % approx. 1 digit
<b>Operation</b>	Mode Indication Function Interface (REBUS)	4 front buttons or interface 4 LEDs Setting of display range and limit values TTL level. Not electrically isolated from the measuring input
<b>Power supply</b>	24 V DC	21 ... 30 V DC, 180 mA approx.
<b>Ambient conditions</b>	Operating temperature Storage temperature Protection class front Climatic class Safety class Device safety EMC immunity EMC radiated interference	0 ... 50 °C - 20 ... 70 °C IP 20 to IEC EN 60 529 IP 50, IP 54 on request Class 2 VDE/DIN 3540 I to IEC EN 61 010-1 to IEC EN 61 010 DIN EN 61 000-4-1 to 4 DIN EN 50 081 class B

<b>Dimensions and weights</b>	Front bezel size Panel cut-out Overall depth Weight	96 mm x 24 mm to DIN 43 718 91-0.5 mm x 22.2-0.3 mm 194 mm 280 g approx.
<b>Sundry</b>	Connections	Plug-in screw terminal blocks
<b>Order details</b>	Model : Measuring input : Display : Display caption : Options : Supply voltage :	Example  DPM 24/96-10.000 MF - 2 ... + 8 V 2.0 ... 12.0 pH 2 limit values, fail-safe 24 V DC

# DPM 24/96-10,000 P

# DPM 48/96-10,000 P



- ▶ One, or Two measuring inputs
- ▶ User-friendly full 4-digit models
- ▶ Internal processor based design
- ▶ Easy configuration via front buttons, or serial interface
- ▶ Up to four Alarm limit relays (DPM 48/96 P)
- ▶ Analogue output
- ▶ Comprehensive choice of measuring ranges
- ▶ 'Wide-range' power supply

Adaptable processor based instruments that can have one or two factory fitted measuring inputs. They feature a powerful selection of scaling and control facilities that can be simply configured using the front buttons, or via the built-in serial interface. Input range options include current and voltage, DC and AC, thermocouple and Pt 100 temperature sensors. Front panel LEDs show the DPM's operational status and output options include open-collector, relay and analogue. Choice of low-profile, or normal DIN-standard housings, both with a 'wide-range' power supply.

Display	Display range	9999
	Decimal point position	programmable
	Negative input indication	"-" (to -1999)
	Digit height	14 mm / 7-segment digits
	Overload/underload indication	display " - - - - " / "FAIL"
Display range	zero-point and full-scale value can be set	
Measuring signal scaling	according to internal functions, or user defined values (10 point 'look-up' table)	
Mathematical functions	two measured values can be combined using the four basic arithmetic operations, pre-set functions can be called up	
Displayed value	direct measured value, or scaled according to internal functions	
Indicators	2 LEDs, functions user-definable (4 LEDs for DPM 48/96 P)	

## Measuring ranges (Options must be specified)

Number of inputs	up to 2 cards with a choice of measuring ranges (can be provided potentially isolated from each other)
Conversion rate per channel	3/s approx. (10/s optional)
Internal resolution	max. 14 bit
<b>Direct voltage</b>	
Measuring range	0 ... 20 mV to 0 ... 250 V
Input impedance	> 1 MΩ
Accuracy	0.05 %, 0.05 %
plus zero point error	
Temperature coefficient	< 70 ppm/°C,
plus zero point drift	< 50 ppm/°C
Series mode rejection	> 60 dB (50 Hz)
<b>Direct current</b>	
Measuring range	0...20 μA to 0...200 mA
Overload	< 20%
Voltage drop	150 mV approx.
Accuracy	0.05 %, 0.05 %
plus zero point error	
Temperature coefficient	< 70 ppm/°C,
plus zero point drift	< 50 ppm/°C
Series mode rejection	> 60 dB (50 Hz)
<b>Alternating voltage</b>	
Sine wave, or true RMS	
Measuring range	0 .. 60 mV to 0 .. 250 V
Overload	< 350V
Input impedance	> 20 kΩ/V
Setting time	< 6 s (99 %)
Accuracy	0.2 %, 0.2 %
plus zero point error	
Temperature coefficient	< 100 ppm/°C,
plus zero point drift	< 100 ppm/°C
Frequency range	15 Hz ... 4 kHz
<b>Alternating current</b>	
Sine wave, or true RMS	
Measuring range	0 ... 20 μA to 0 ... 1A
Overload	< 20 %
Voltage drop	approx. 150 mV
Setting time	< 6 s (99 %)
Accuracy	0.2 %, 0.2 %
plus zero point error	
Temperature coefficient	< 100 ppm/°C,
plus zero point drift	< 100 ppm/°C
Frequency range	15 Hz ... 4 kHz

	<p><b>Temperature with thermocouple sensor</b></p> <p>Measuring range</p> <p>Input impedance</p> <p>Maximum line resistance</p> <p>Setting time</p> <p>Accuracy plus zero point error</p> <p>Linearisation error</p> <p>Temperature coefficient plus zero point drift</p> <p>Internal reference junction error</p> <p>Broken sensor programmable</p>	<p>NiCr-Ni (K) 0 ... 1200 °C</p> <p>Fe-CuNi (J or L) 0 ... 900 °C</p> <p>Cu-Cu-Ni (T or U) 0 ... 600 °C</p> <p>PtRh-Pt 10 % (S) 400 ... 1700 °C</p> <p>PtRh-Pt 13 % (R) 500 ... 1700 °C</p> <p>PtRh-Pt 18 % (B) 600 ... 1800 °C</p> <p>approx. 1 MΩ</p> <p>100 Ω per line, influence &lt; 5 µV/10 Ω</p> <p>&lt; 2 s</p> <p>0.05 %, 0.05 %</p> <p>&lt; 0.3 %</p> <p>&lt; 100 ppm/°C, &lt; 100 ppm/°C</p> <p>&lt; 0.3 % or 1.5 °C (max value)</p> <p>to indicate initial value or final value</p>
	<p><b>Temperature with Pt 100 resistance sensor</b></p> <p>Measuring ranges</p> <p>Max. sensor current</p> <p>Setting time</p> <p>Accuracy plus zero point error</p> <p>Linearisation error</p> <p>Temperature coefficient plus zero point drift</p> <p>Max. line resistance</p>	<p>- 100 °C ... 850 °C</p> <p>5 mA</p> <p>&lt; 1 s</p> <p>&lt; 0.05 %, &lt; 0.05 %</p> <p>&lt; 0.2 %</p> <p>&lt; 100 ppm/°C, &lt; 50 ppm/°C</p> <p>2L 10 Ω is factory calibrated</p> <p>3L 20 Ω max. per line, symmetrical</p> <p>4L 20 Ω max. per line</p>
<b>Accuracy</b>	<p>Measuring accuracy, basic unit</p> <p>Temperature coefficient</p> <p>zero point drift</p> <p>Additional measuring range error</p> <p>Digital processing additional error</p> <p>non-linear depiction</p> <p>Measuring signal combinations</p> <p>Scaling</p>	<p>0.05 % + 1 digit</p> <p>&lt; 50 ppm/°C, plus &lt; 50 ppm/°C</p> <p>see measuring ranges above</p> <p>1 digit/10 % non-linearity of the input functions</p> <p>1 digit/input function</p> <p>1 digit/100 % change of the display range</p>
<b>Alarm limits</b>	Number of limits	up to 2, freely allocated over measuring ranges, up to 6 for (DPM 48/96 P)

<b>Operation</b>	Via front buttons	
	Number of buttons	2 (DPM 24/96 P) 4 (DPM 48/96 P)
<b>Configuration</b>	Via front buttons or serial interface	
	Configuration software available	
<b>Output signals</b>	Open collector Relays (DPM 48/96 P) relay ratings Analogue output Setting time Resolution Accuracy	up to 2 can be allocated to any displayed value(s) up to 4 can be allocated to any displayed value(s) 30 V, 1 A max. 0 ... 10 V, or 4 ... 20 mA, scalable < 1s (99 %) 1000 steps approx. 0.2 % approx. related to internal controller value
<b>Digital signals</b>	Interface	RS 232
<b>Power supply</b>		19 ... 36 V DC and 115/230 V AC, 7 W approx.
<b>Environmental conditions</b>	Operating temperature Storage temperature Protection class front Climatic class Safety class Device safety EMC immunity EMC radiated interference	0 ... 50 °C - 40 ... 80 °C IP 20 to IEC DIN 60 529 IP 54 (IP 65 on request) Class 2 to VDE/DIN 3540 II to IEC 348 / VDE 0411 to IEC EN 61 010 DIN EN 61 000-4-1 to 4 DIN EN 50 081 class B

**Dimensions and weights**

Bezel size  
Panel cut-out  
  
Overall depth  
Weight

**DPM 24/96 P**  
96 mm x 24 mm  
92+0.8 mm x 22.2+0.3 mm  
  
143 mm  
270 g

**DPM 48/96 P**  
96 mm x 48 mm  
92+0.8 mm x 45.5+0.6 mm  
143 mm  
470 g max.

**Sundry**

Connections

Plug-in screw terminal blocks  
Direct screw terminals (measuring ranges)

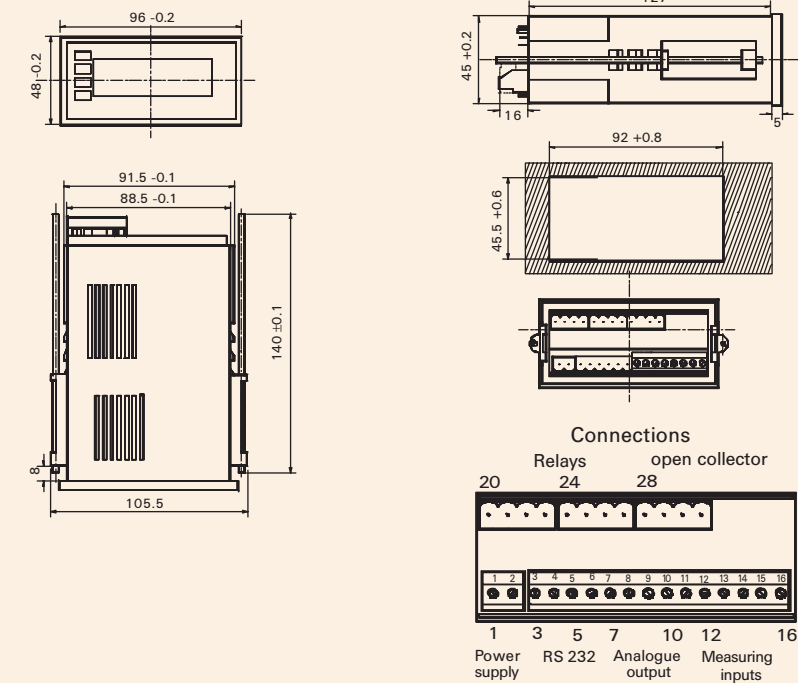
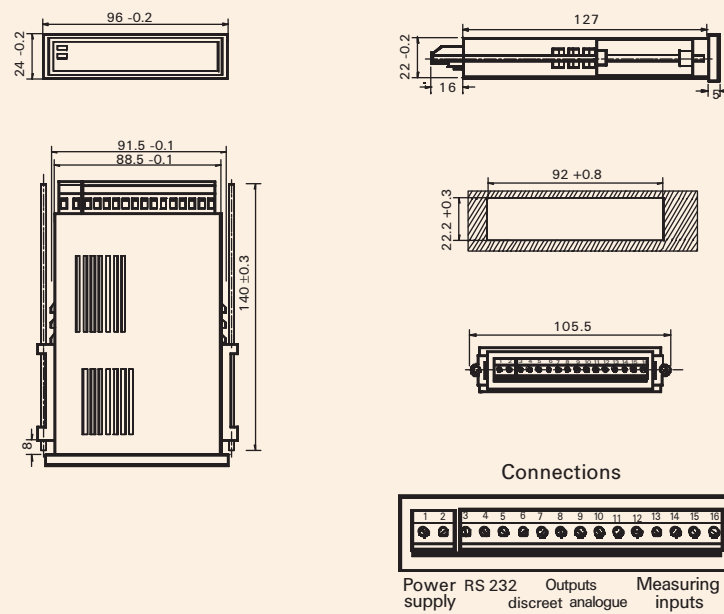

**Order details**

Model : .....  
Measuring input 1 : .....  
Measuring input 2 : .....  
Display : .....  
Display caption : .....  
Options : .....  
Supply voltage : .....

Example  
DPM 24/96-10000 P  
- 2 ... + 8 V  
- 2 ... + 8 V  
2.0 ... 12.0  
kW  
2 limit values  
24 V DC

# DPM 24/96-10,000 Z

# DPM 48/96-10,000 Z

please contact us



- ▶ **User-friendly 5 digit counters**
- ▶ **One or two counter inputs**
- ▶ **Configuration via front keys or RS232 interface**
- ▶ **Programmable internal time base**
- ▶ **Two built-in limit relays (DPM 48/96)**

Self-contained digital counters for simple counting and more sophisticated applications in process control and laboratory environments. Having dual counter inputs with open-collector, relay and analogue outputs make these counters powerful units in any automation application. The built-in interface also enables these counters to be used in computer controlled plant systems.

<b>Display</b>	<p>Display range Decimal point position Negative value indication Digit height Overflow indication Display range</p>	<p>99999 programmable “-“ (to -19999) 14 mm / 7-segment digits programmable, flashing initial value pre-settable per channel built-in divider (1/10)</p>
	Count signal scaling	according to internal functions, or customer defined functions possible
	Count signal combinations	two count values can be mathematically combined using the 4 basic arithmetic functions, or one input can be combined with a value via the serial interface
	Display value	direct counted value, or scaled according to internal functions, or values from the interface, or time base interval
	Front indicators	2 LEDs, freely definable (DPM 24/96) 4 LEDs, freely definable (DPM 48/96)

<b>Inputs</b>	<p>Number of inputs</p> <p>Counter range per channel Internal resolution accuracy Level (sinusoidal or pulse)</p> <p>pulse width frequency</p> <p>Internal time base Time period measurement accuracy</p>	<p>up to two inputs, freely combinable inputs for DPM 48/96-10,000 can be potentially isolated 99999 999999 with divider (1/100) better than 2 digits TTL-level 1 V up to 100 V possible (Options) 20 µs min. 10 kHz max.</p> <p>0.1 s up to 100 s or none, user configurable 1 period up to 100 periods, user configurable better than 2 digits</p>
<b>Accuracy</b>	<p>Additional digital processing error Non-linear scaling Counter signal combination Scaling</p>	<p>1 digit/10 % non-linearity of the input function 1 digit/input function 1 digit/100 % alteration of the display range</p>
<b>Alarm limits</b>	Number of limits	<p>up to 2 (DPM 24/96) up to 4 (DPM 48/96)</p>
<b>Operation</b>	<p>Via front panel buttons Number of buttons</p>	<p>2 (DPM 24/96) 4 (DPM 48/96)</p>
<b>Configuration</b>		via front buttons, or RS232 serial interface configuration software available
<b>Output signals</b>	<p>Open collector Relays (DPM 48/96) Relay ratings Analogue output Setting time Resolution Accuracy</p>	<p>up to 2, freely allocable to any display value(s) up to 2, freely allocable to any display value(s) 30 V, 1 A One (0 ... 10 V, or 4 ... 20 mA) freely scalable &lt; 1s (99 %) approx. 1000 steps approx. 0.5 %, in relation to internal controller value</p>
<b>Digital signals</b>	Interface	RS 232
<b>Power supply</b>		19 ... 36 V DC and 115/230 V AC, 7 W approx.
<b>Ambient conditions</b>	<p>Operating temperature Storage temperature Protection class front Climatic class Safety class Device safety EMC immunity EMC radiated interference</p>	<p>0 ... 50 °C - 40 ... 80 °C IP 20 to IEC DIN 60 529 IP 54 (IP 65 on request) Class 2 to VDE/DIN 3540 II to IEC 348 / VDE 0411 to IEC EN 61 010 DIN EN 61 000-4-1 to 4 DIN EN 50 081 class B</p>

**Dimensions and weights**

Front bezel size  
Panel cut-out

Overall depth  
Weight

DPM 24/96 Z	DPM 48/96 Z
96 mm x 24 mm	96mm x 48 mm
92+0.8 mm x 22.2+0.3mm	92+0.8 mm x 45.5+0.6 mm
143 mm	143 mm
270 g	470 g max.

**Sundry**

Connections

plug-in screw terminal blocks  
direct screw connections (counter inputs)

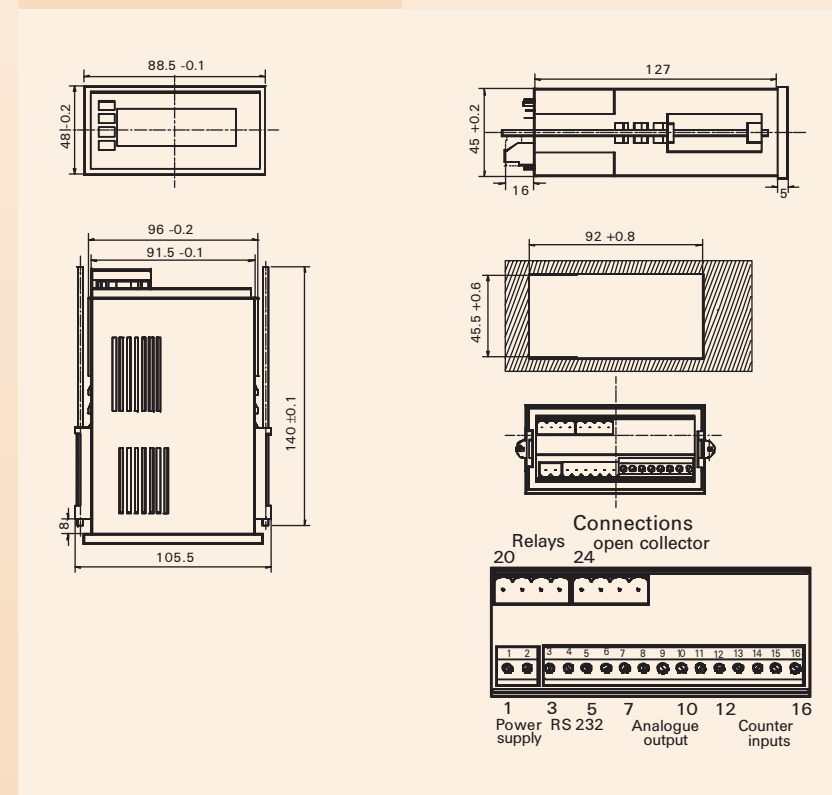
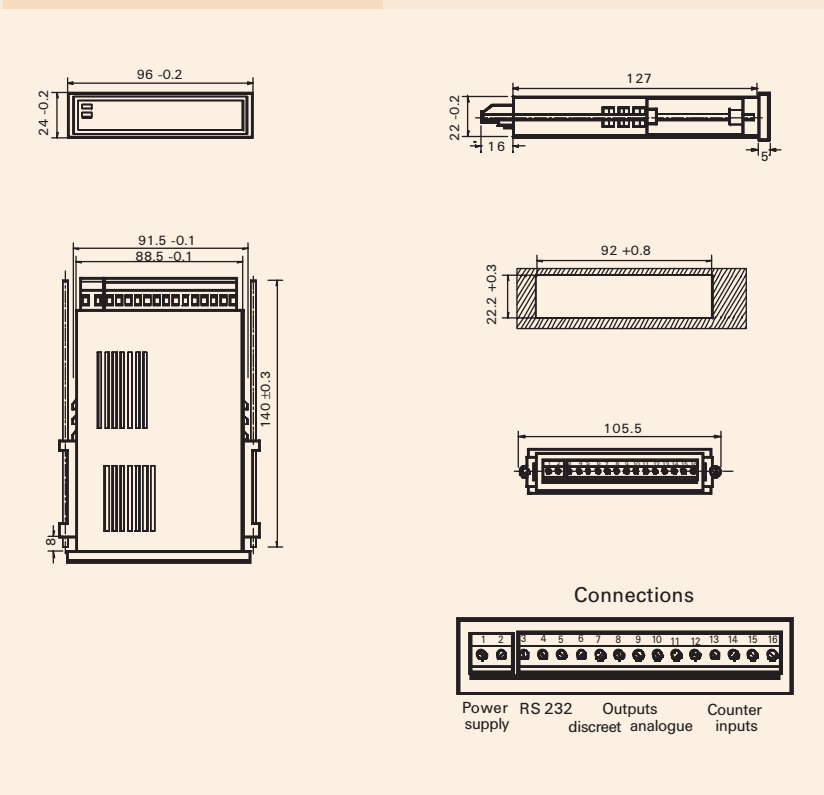

**Order details**

Model : .....  
 Counting input : .....  
 Time base : .....  
 Display : .....  
 Display caption : .....  
 Options : .....  
 Supply voltage : .....

**Example**

DPM 24/96-10.000 Z  
 20 ... 200 Hz  
 30 s  
 pcs.  
 24 V DC

# DPM 24/96-40,000 MF

# DPM 48/96-40,000 MF ..



- ▶ Multifunction full 5-digit models
- ▶ Internal processor based design
- ▶ Comprehensive choice of measuring ranges
- ▶ Easy configuration via buttons, or serial interface
- ▶ Up to 4 relay switching outputs, 2 open collectors
- ▶ Analogue output options
- ▶ RS 232 and RS 485 interface options
- ▶ Data logging facilities
- ▶ 'Wide-range' power supply

Adaptable processor based instruments available in a choice of low-profile, or normal DIN-standard housings, both with a 'wide-range' power supply. They feature a powerful selection of scaling and control facilities that can be simply configured using the front buttons, or via the built-in serial interface to meet virtually any measurement or automation application. The serial interfaces enables these models to be integrated into PC/PLC remote control systems. Alternatively, measured or recorded data can be sent to a serial printer. The measuring inputs can be configured and scaled for current and voltage (DC, AC and TRMS), thermocouple and Pt 100 temperature sensors. Front panel LEDs show the DPM's operational status and output options include open-collector, relay and analogue.

## Display

A/D conversion range  
Display range  
Display of

Display memory  
Decimal point position  
Negative display indication  
Digit height  
Overload indication  
LED indicators  
for MFE ..

- 19999 to + 40000 counts  
- 19999 to + 99999, freely scalable  
direct measured, or internally scaled value  
or values from the interface  
Min, Max or display HOLD value  
programmable  
„-“ (to -19999)  
14 mm / 7-segment digits  
programmable, flashing  
2 programmable LEDs (trend or alarms)  
9 additional status LEDs (alarms, memory)

Facilities	Display scaling	by built-in linear or standard non-linear functions user definable scaling (up to 25 point 'look-up table')
	DPM ... MFE ..	can average up to 250 measurements to remove noise
	Input filtering	limit values, actions and reset modes are selectable
	Alarm configuration	up to 180 values with selectable time base, trigger and reset modes, and results output to printer (continuous, or on request), or for remote control by PC/PLC
Operation	DATA-logging memory	values from two, or more, DPMs (linked via their serial interfaces) can be combined mathematically
	RS232 interface	RS232 and RS485 (MFE 1) interfaces are addressable for serial control by a master PLC, etc.
	Cascading	
	LOOP operation	
Measuring ranges	Programmable buttons	can be inhibited and code locked
	number of buttons	two (four for the MFE .. versions)
	functions available	Hold, Min, Max, automatic TARE, or transmit value to serial interface
	special functions	alarm configuration, data logging control
DPM ... MF	Control input (one)	same functions available as programmable buttons
	RS232 interface	full remote control possible by PC or PLC
	Voltage DC mV	200 / 400 mV
	Accuracy	0.05 % f. s. 4 digits
DPM ... MFE .. only	Input resistance	> 100 MΩ
	Voltage DC V	2 / 4 / 20 / 40 / 200 / 400 / 650 V
	Accuracy	0.03 % f. s. 3 digits
	Input resistance	> 2 MΩ
DPM ... MF	Temperature coefficient	< 50 ppm/°C
	Current DC mA	20 / 40 mA (higher with external shunt)
	Current shunt	10Ω
	Accuracy	0.04 % ± 3 digits
DPM ... MF	Temperature coefficient	< 100 ppm/°C
	Voltage AC mV	500 / 1000 mV
	Accuracy	0.2 % f. s. 4 digits
	Input impedance	> 100 MΩ
DPM ... MF	Frequency influence	2 % (40 ... 400 Hz)
	Voltage AC V	5 / 10 / 50 / 100 / 500 / 650 V
	Accuracy	0.2 % f. s. 4 digits
	Input impedance	> 2 MΩ
DPM ... MF	Frequency influence	0.1 % (40 ... 400 Hz)
	Temperature coefficient	< 100 ppm/°C
	Current AC mA	50 / 100 mA
	Current shunt	10Ω
DPM ... MF	Accuracy	0.2 % 4 digits
	Frequency influence	0.1 % (40 ... 400 Hz)
	Temperature coefficient	< 125ppm/°C
	TRMS measurement	
DPM ... MF-E .. only	Crest factor	4 (max. crest value +50 % of measured value)
	Frequency influence	30 ... 1500 Hz - 0.1 %
		15 ... 2500 Hz - 1 %
		5 ... 5000 Hz - 5 %



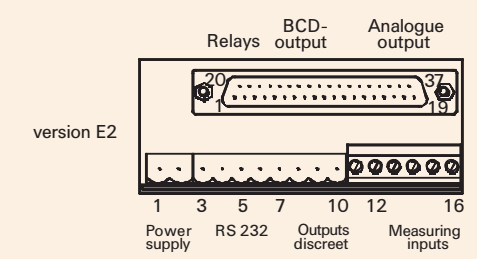
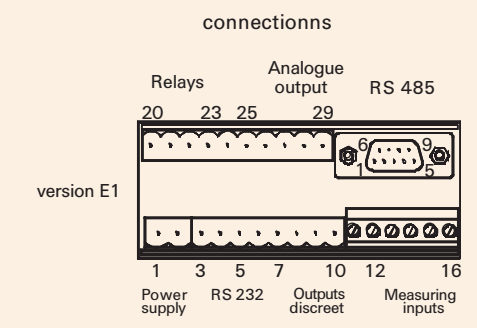
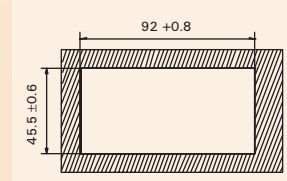
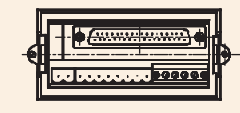
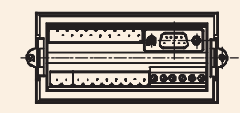
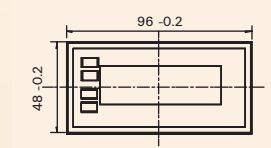
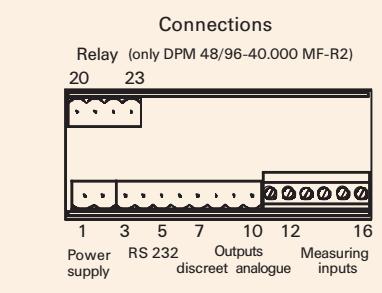
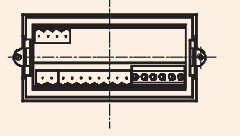
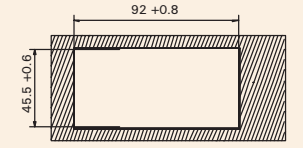
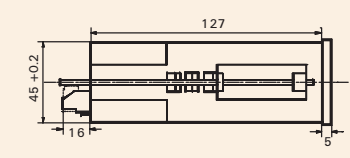
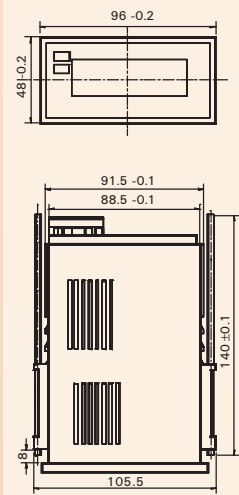
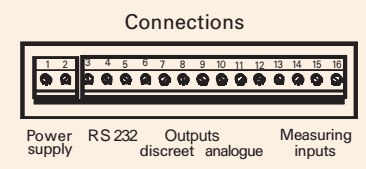
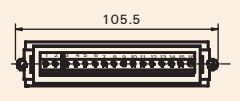
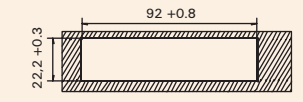
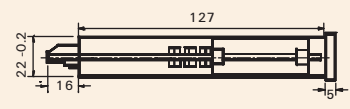
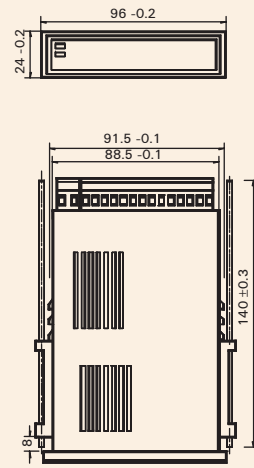

**Order details**

Model : .....  
 Measuring input : .....  
 Display : .....  
 Analogue output : .....  
 Display caption : .....  
 Options : .....  
 Power supply : .....  
 Additional order details : .....  
 Software : .....

**Example**

DPM 24/96-40.000 MF  
 - 2 ... + 8 V  
 2,0 ... 12,0  
 4 mA ... 20 mA  
 pH  
 Maximum value storage  
 24 V DC

(Parameter setting on request)  
 PC-DPM with cable for SUB-D (9-pin)

# Plug-in Card Selection

for DPM 48/96 2000 N, 20.000 N and DPM 24/96-10.000 MF

<b>Direct voltage</b> Measuring ranges Zero offset (suppression) Input impedance Accuracy Temperature coefficient Series mode rejection	0 ... 10 mV to 0 ... 250 V, overload 350 V max. up to 50 % of full-scale value 1 k $\Omega$ /V approx. for ranges < 200 mV, otherwise > 1 M $\Omega$ 0.05 %, plus 0.05 % zero point error < 70 ppm/°C, plus < 50 ppm/°C zero point drift > 60 dB (50 Hz)	<b>Temperature with thermocouple sensors</b> Measuring ranges (Max. overvoltage < 100 V)	NiCr-Ni (K) 0 ... 1200 °C Fe-CuNi (J or L) 0 ... 900 °C Cu-Cu-Ni (T or U) 0 ... 600 °C PtRh-Pt 10 % (S) 400 ... 1700 °C PtRh-Pt 13 % (R) 500 ... 1700 °C PtRh-Pt 18 % (B) 600 ... 1800 °C
<b>Direct current</b> Measuring range Zero offset (suppression) Voltage drop Accuracy Temperature coefficient Series mode rejection	0 ... 20 $\mu$ A to 0 ... 200 mA, overload 50 % max. up to 50 % of full-scale value 150 mV approx. 0.1 %, plus 0.05 % zero point error < 70 ppm/°C, plus < 50 ppm/°C zero point drift > 60 dB (50 Hz)	Input impedance Max. allowable line resistance Setting time Accuracy Linearisation accuracy Temperature coefficient Internal reference junction accuracy Series mode rejection Broken sensor detection	10 M $\Omega$ approx. 100 $\Omega$ , each line < 2 s 0.05 %, plus 0.05 % zero point error < 0.3 % f. s. < 100 ppm/°C, plus < 50 ppm/°C zero point drift < 0.3 % f. s. for 0 ... 40 °C ambient temperature > 60 dB is indicated by display
<b>Alternating voltage AC Sine wave</b> Measuring ranges Input impedance Accuracy Temperature coefficient Frequency range	0 ... 60 mV to 0 ... 250 V, overload 350 V max. 100 k $\Omega$ /V typical, 1 M $\Omega$ max. 0.2 %, plus 0.2 % zero point error < 150 ppm/°C, plus < 100ppm/°C zero point drift 35 Hz ... 2 kHz	<b>Temperature with Pt 100 resistance sensor</b> Measuring ranges Max. sensor current Setting time Accuracy Linearisation accuracy Temperature coefficient Max. allowable line resistance	- 100 °C ... 850 °C 5 mA < 1 s 0.05 %, plus 0.05 % zero point error < 0.2 % < 100 ppm/°C, plus < 50 ppm/°C zero point drift 10 $\Omega$ is factory calibrated (DIN 43 701) 20 $\Omega$ per line, symmetrical 20 $\Omega$ per line
<b>Alternating current AC Sine wave</b> Measuring ranges Voltage drop Accuracy Temperature coefficient Frequency range	0 ... 10 $\mu$ A to 0 ... 1 A, overload 50 % max. 60 mV approx. 0.2 %, plus 0.2 % zero point error < 150 ppm/°C, plus < 100ppm/°C zero point drift 35 Hz ... 2 kHz	2L 3L 4L	2L 3L 4L
<b>Alternating voltage true RMS</b> Measuring ranges Input impedance Setting time Accuracy Max. allowable crest factor Zero point error Temperature coefficient Frequency range	0 ... 60 mV to 0 ... 250 V, overload 350 V max. 20 k $\Omega$ /V typical. 50 k $\Omega$ min. 2 M $\Omega$ max. < 6 s (99 %) 0.5 % of range, plus 0.15 % f. s. $\pm$ 1 digit 3 ... 6 0.2 % < 100 ppm/°C, plus < 100 ppm/°C zero point drift DC, 15 Hz ... 10 kHz	<b>Temperature with Ni 100 resistance sensor</b> Measuring ranges Max. sensor current Setting time Accuracy Linearisation accuracy Temperature coefficient Max. allowable line resistance	- 20 °C ... 130 °C 5 mA < 1 s 0.05 %, plus 0.05 % zero point error < 0.2 % < 100 ppm/°C, plus < 50 ppm/°C zero point drift 10 $\Omega$ is factory calibrated (DIN 43 701) 20 $\Omega$ per line, symmetrical 20 $\Omega$ per line
<b>Alternating current true RMS</b> Measuring ranges Voltage drop Setting time Accuracy Max. allowable crest factor Zero point error Temperature coefficient Frequency range	0 ... 2 mA to 0 ... 2A, overload below 50 % 60 mV approx. < 6 s (99 %) 0.5 % of measured value, plus 0.5 % f. s. $\pm$ 1 digit 3 ... 6 0.2 % < 100 ppm/°C, plus < 100 ppm/°C zero point drift DC, 15 Hz ... 10 kHz	<b>Resistance or Potentiometer</b> Measuring ranges	2L 20 $\Omega$ ... 200 k $\Omega$ 3L 20 $\Omega$ ... 200 k $\Omega$ 4L 20 $\Omega$ ... 200 k $\Omega$ 200 $\Omega$ ... 200 k $\Omega$ 20 $\Omega$ up to 50 % f. s. 5 mA (max. voltage at sensor 1.2 V) 0.05 % f. s. < 150 ppm/°C, plus < 50 ppm/°C zero point drift 10 $\Omega$ is factory calibrated (DIN 43 701) 20 $\Omega$ per line, symmetrical 20 $\Omega$ per line
<b>Frequency measurement</b> Measuring ranges Overload at input voltage Measuring voltage/input impedance Accuracy Temperature coefficient	20... 199.9(9) Hz; 20... 1999.(9) Hz; 0.02... 10.00(0) kHz to 25 V overload 100V; to 250 V overload 350 V 2.5 ... 25 V/100 k $\Omega$ ; 25 ... 250 V/1 M $\Omega$ 0.5 %, plus 0.2 % zero point error < 150 ppm/°C, plus < 50 ppm/°C zero point drift	(for DPM 48/96-20000N) Lowest measuring range Range offset (suppression) Max. measuring current Accuracy Temperature coefficient Max. allowable line resistance	2L 20 $\Omega$ ... 200 k $\Omega$ 3L 20 $\Omega$ ... 200 k $\Omega$ 4L 20 $\Omega$ ... 200 k $\Omega$ 200 $\Omega$ ... 200 k $\Omega$ 20 $\Omega$ up to 50 % f. s. 5 mA (max. voltage at sensor 1.2 V) 0.05 % f. s. < 150 ppm/°C, plus < 50 ppm/°C zero point drift 10 $\Omega$ is factory calibrated (DIN 43 701) 20 $\Omega$ per line, symmetrical 20 $\Omega$ per line
<b>Direct voltage/Direct current - Switchable (only DPM24/96-10,000 MF)</b> Measuring ranges Accuracy Temperature coefficient	0 ... 1 mA, 0 ... 20 mA, 4 ... 20 mA (Voltage drop < 150 mV) 0 ... 10 V (Input impedance approx. 130 k $\Omega$ ) via DIP switch 10 times max. 0.1 %, plus 0.05 % zero point error < 150 ppm/°C, plus < 100 ppm/°C zero point drift	Current Voltage Range setting Overload Accuracy Temperature coefficient	0 ... 1 mA, 0 ... 20 mA, 4 ... 20 mA (Voltage drop < 150 mV) 0 ... 10 V (Input impedance approx. 130 k $\Omega$ ) via DIP switch 10 times max. 0.1 %, plus 0.05 % zero point error < 150 ppm/°C, plus < 100 ppm/°C zero point drift