

TS8GSSD25S-Si
TS16GSSD25S-Si

TS32GSSD25S-Si
TS64GSSD25S-Si

2.5" Industrial Wide Temp.
SATA II Solid State Disk

Description

Due to smaller size (fit the standard dimensions of 2.5" SATA Hard Disk Drives), huge capacity, high speed, low power consumption and wide temperature operating, Solid State Disk is perfect replacement storage device for PCs, Laptops, gaming systems, and handheld devices.

- Fully compatible with SATA II 3Gb/s standard
- Built-in ECC and wear-leveling to ensure reliability of data transfer
- - Support Hardware Purge function

Features

- RoHS compliant
- Fully compatible with devices and OS that support the SATA II 3Gb/s standard
- Non-volatile Flash Memory for outstanding data retention
- Built-in ECC (Error Correction Code) functionality and wear-leveling algorithm ensures highly reliable of data transfer
- Shock resistance
- Support Hardware Purge function

Placement



Dimensions

Side	Millimeters	Inches
A	100.30 ± 0.40	3.949 ± 0.016
B	69.85 ± 0.20	2.750 ± 0.008
C	9.50 ± 0.15	0.374 ± 0.004

TS8GSSD25S-Si
TS16GSSD25S-Si

TS32GSSD25S-Si
TS64GSSD25S-Si



2.5" Industrial Wide Temp.
SATA II Solid State Disk

Specifications

Physical Specification		
Form Factor	2.5-inch HDD	
Storage Capacities	8 GB to 64 GB	
Dimensions (mm)	Length	100.0 0 ± 0.40
	Width	69.85 ± 0.20
	Height	9.50 ± 0.15
Input Voltage	5V ± 5%	
Weight	66g ± 5g	
Connector	SATA 7+15 pins combo connector	

Environmental Specifications		
Operating Temperature	- 40 °C to 85 °C	
Storage Temperature	- 40 °C to 85 °C	
Humidity	Operating	0% to 95% (Non-condensing)
	Non-Operating	0% to 95% (Non-condensing)

Performance						
Model P/N	Sequential Read*	Sequential Write*	Random Read (4KB QD32)*	Random Write (4KB QD32)*	IOPS Random Read (4KB QD32)**	IOPS Random Write (4KB QD32)**
TS8GSSD25S-S	140	70	17.95	0.148	4647.01	847.86
TS16GSSD25S-S	140	110	17.68	0.25	4606.85	769.42
TS32GSSD25S-S	140	110	17.73	0.267	4619.76	753.29
TS64GSSD25S-S	175	145	18.09	2.739	4708.886	614.7505

Note: Maximum transfer speed recorded

* 25 °C, test on ASUS P5Q-Pro, 2GB, Windows® XP Version SP3 with AHCI mode, benchmark utility CrystalDiskMark (version 3.0), copied file 1000MB, unit MB/s

** Random read/write performance based on Iometer2006 with 4K file size and queue depth of 32, unit IOPS

*** The recorded performance is obtained while the SSD is not operating as an OS disk

TS8GSSD25S-Si
TS16GSSD25S-Si

TS32GSSD25S-Si
TS64GSSD25S-Si



2.5" Industrial Wide Temp.
SATA II Solid State Disk

Actual Capacity				
Model P/N	LBA	Cylinder	Head	Sector
TS8GSSD25S-S	15,621,984	15,498	16	63
TS16GSSD25S-S	31,277,056	16,383	16	63
TS32GSSD25S-S	62,586,880	16,383	16	63
TS64GSSD25S-S	125,206,528	16,383	16	63

Power Requirements		
Input Voltage		5V ± 5% @ 25 °C
Mode P/N / Power Consumption		Typical (mA)
TS8GSSD25S-S	Read	262.4
	Write	298.3
	Idle	138.3
TS16GSSD25S-S	Read	323
	Write	360.3
	Idle	135.9
TS32GSSD25S-S	Read	307.1
	Write	416.1
	Idle	149.7
TS64GSSD25S-S	Read	301
	Write	394.3
	Idle	138.4

*Tested with IOMeter running sequential reads/writes and idle mode

Reliability		
Data Reliability	Supports BCH ECC 8 bits or 15 bits in 512 bytes	
Data Retention	10 years	
MTBF	1,000,000 hours	
Endurance (Terabytes Written)	8G	8 TBW
	16G	16 TBW
	32G	32 TBW
	64G	128 TBW



TS8GSSD25S-Si

TS32GSSD25S-Si

TS16GSSD25S-Si

TS64GSSD25S-Si

**2.5" Industrial Wide Temp.
SATA II Solid State Disk**

Vibration	
Operating	3.0G, 5 - 800Hz
Non-Operating	3.0G, 5 - 800Hz

* Note: Reference to the IEC 60068-2-6 Testing procedures; Operating-Sine wave, 5-800Hz/1 oct., 1.5mm, 3g, 0.5 hr./axis, total 1.5 hrs.

Shock	
Operating	1500G, 0.5ms
Non-Operating	1500G, 0.5ms

* Note: Reference to the IEC 60068-2-27 Testing procedures; Operating-Half-sine wave, 1500g, 0.5ms, 3 times/dir., total 18 times.

Regulations	
Compliance	CE, FCC and BSMI

TS8GSSD25S-Si
 TS16GSSD25S-Si

TS32GSSD25S-Si
 TS64GSSD25S-Si



2.5" Industrial Wide Temp.
 SATA II Solid State Disk

Package Dimensions

Below figure illustrates the Transcend 2.5" SATA Solid State Disk. All dimensions are in mm.

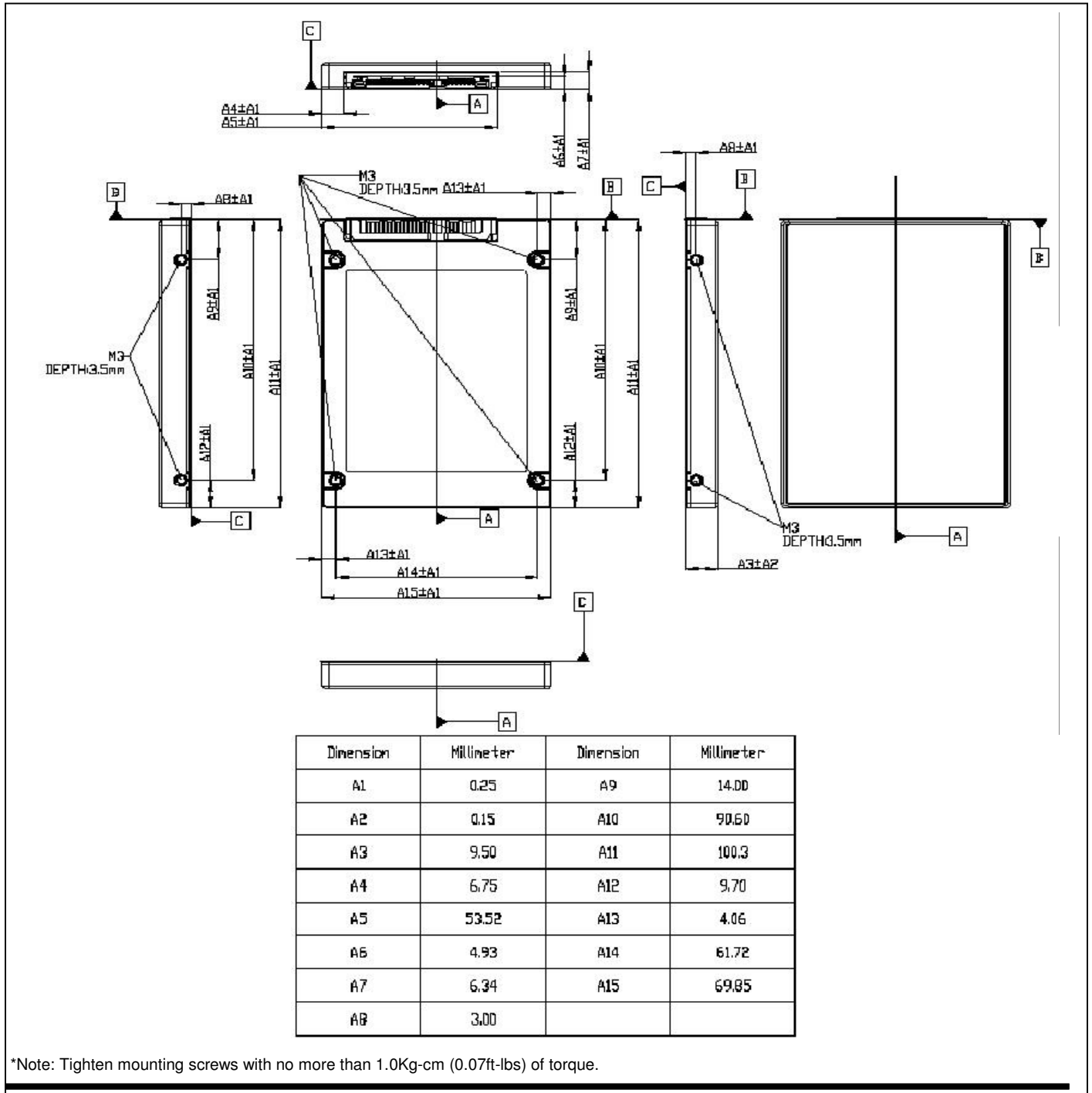

TS8GSSD25S-Si
 TS16GSSD25S-Si

TS32GSSD25S-Si
 TS64GSSD25S-Si



2.5" Industrial Wide Temp.
 SATA II Solid State Disk

Pin Assignments

Pin No.	Pin Name	Pin No.	Pin Name
01	GND	02	A+
03	A-	04	GND
05	B-	06	B+
07	GND	08	NC
09	NC	10	NC
11	GND	12	GND
13	GND	14	5V
15	5V	16	5V
17	GND	18	GND
19	GND	20	NC
21	NC	22	NC

Pin Layout

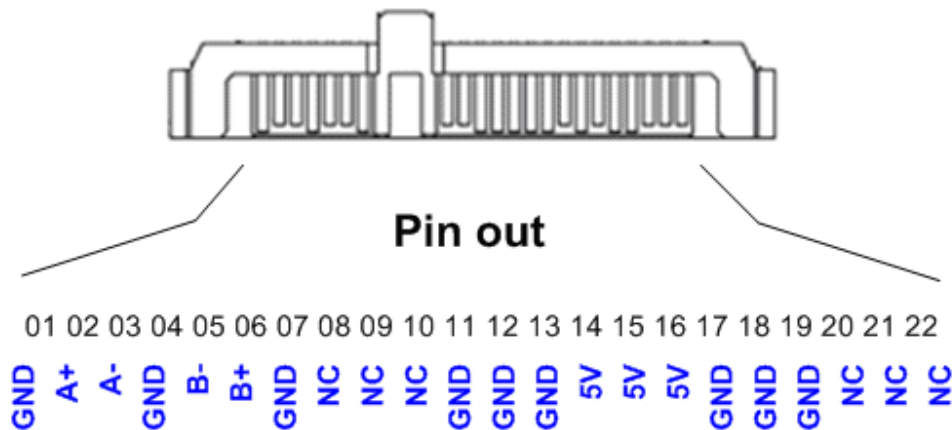

TS8GSSD25S-Si
TS16GSSD25S-Si

TS32GSSD25S-Si
TS64GSSD25S-Si



2.5" Industrial Wide Temp.
SATA II Solid State Disk

Block Diagram

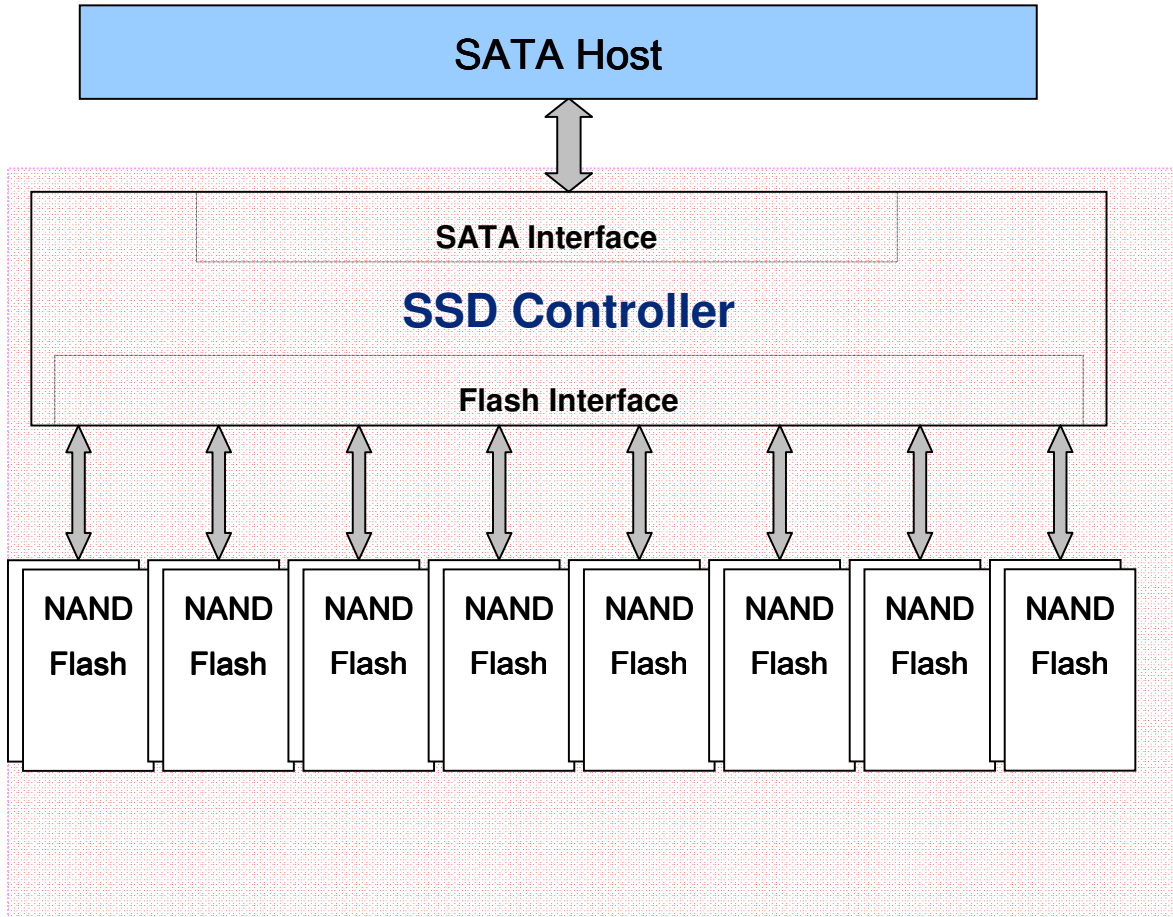

TS8GSSD25S-Si
TS16GSSD25S-Si

TS32GSSD25S-Si
TS64GSSD25S-Si



2.5" Industrial Wide Temp.
SATA II Solid State Disk

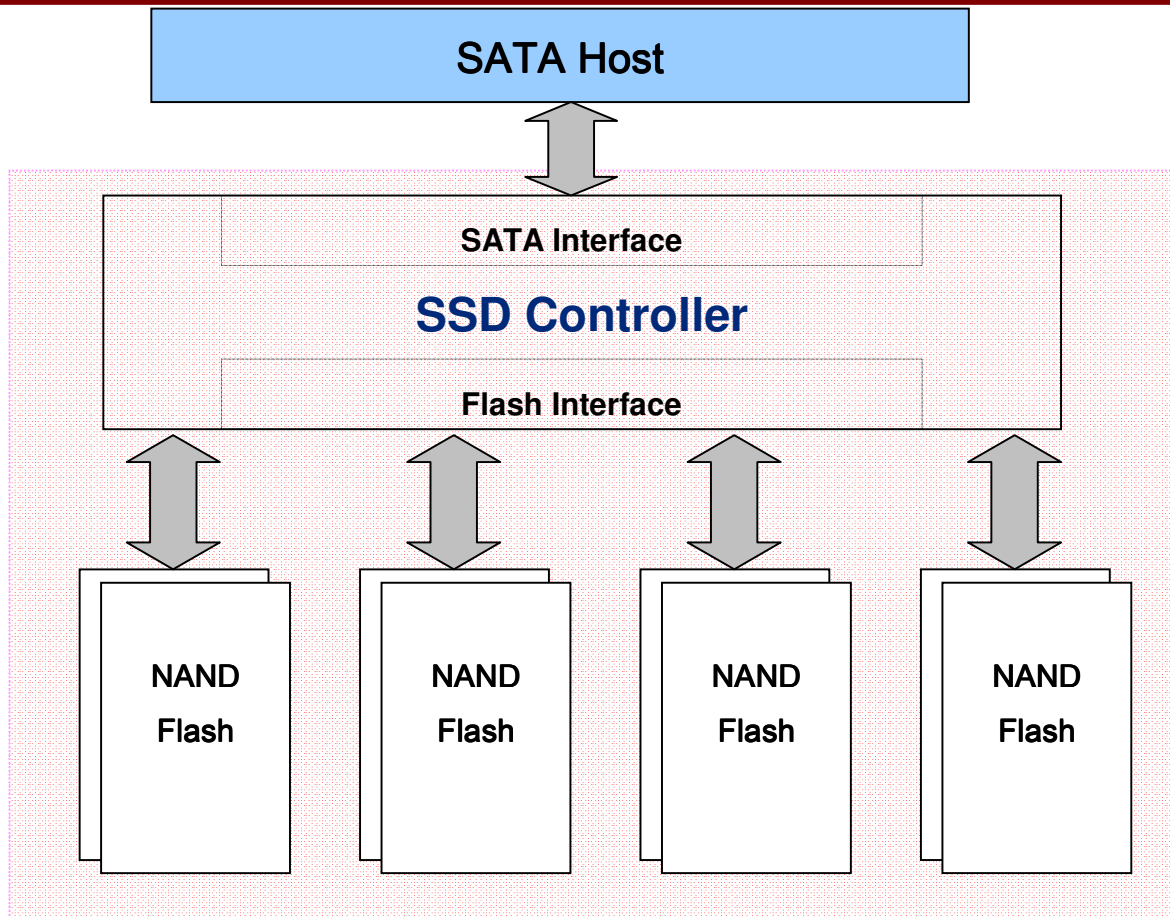

TS8GSSD25S-Si
TS16GSSD25S-Si

TS32GSSD25S-Si
TS64GSSD25S-Si



2.5" Industrial Wide Temp.
SATA II Solid State Disk

Reliability

Wear-Leveling algorithm

The controller supports static/dynamic wear leveling. When the host writes data, the controller will find and use the block with the lowest erase count among the free blocks. This is known as dynamic wear leveling. When the free blocks' erase count is higher than the data blocks', it will activate the static wear leveling, replacing the not so frequently used user blocks with the high erase count free blocks.

ECC algorithm

The controller uses BCH8/BCH15 ECC algorithm per 512 bytes. BCH8/BCH15 can correct up to 8 or 15 random error bits within 512 data bytes.

Bad-block management

When the flash encounters ECC failed, program fail or erase fail, the controller will mark the block as bad block to prevent the used of this block and caused data lost later on.

TS8GSSD25S-Si
TS16GSSD25S-Si

TS32GSSD25S-Si
TS64GSSD25S-Si



2.5" Industrial Wide Temp.
SATA II Solid State Disk

ATA Command Register

This table with the following paragraphs summarizes the ATA command set.

Command Table

Command Name	Code	PARAMETERS USED					
		SC	SN	CY	DR	HD	FT
CHECK POWER MODE	E5h	X	X	X	O	X	X
EXECUTE DIAGNOSTICS	90h	X	X	X	O	X	X
FLUSH CACHE	E7h	X	X	X	O	O	X
FLUSH CACHE EXT	EAh	X	X	X	O	O	X
IDENTIFY DEVICE	ECh	X	X	X	O	X	X
IDLE	E3h	O	X	X	O	X	X
IDLE IMMEDIATE	E1h	X	X	X	O	X	X
INITIALIZE DEVICE PARAMETERS	91h	O	X	X	O	O	X
READ BUFFER	E4h	X	X	X	O	X	X
READ DMA	C8h or C9h	O	O	O	O	O	X
READ DMA EXT	25h	O	O	O	O	O	X
READ FPDMA QUEUED	60h	O	O	O	O	O	O
READ LOG EXT	2Fh	O	O	O	O	O	O
READ MULTIPLE	C4h	O	O	O	O	O	X
READ MULTIPLE EXT	29h	O	O	O	O	O	X
READ SECTOR(S)	20h or 21h	O	O	O	O	O	X
READ SECTOR(S) EXT	24h	O	O	O	O	O	X
READ VERIFY SECTOR(S)	40h or 41h	O	O	O	O	O	X
READ VERIFY SECTOR(S) EXT	42h	O	O	O	O	O	X
RECALIBRATE	10h	X	X	X	O	X	X
SECURITY DISABLE PASSWORD	F6h	X	X	X	O	X	X
SECURITY ERASE PREPARE	F3h	X	X	X	O	X	X
SECURITY ERASE UNIT	F4h	X	X	X	O	X	X
SECURITY FREEZE LOCK	F5h	X	X	X	O	X	X
SECURITY SET PASSWORD	F1h	X	X	X	O	X	X
SECURITY UNLOCK	F2h	X	X	X	O	X	X

TS8GSSD25S-Si
TS16GSSD25S-Si

TS32GSSD25S-Si
TS64GSSD25S-Si



2.5" Industrial Wide Temp.
SATA II Solid State Disk

SEEK	7xh	X	X	O	O	O	X
SET FEATURES	EFh	O	X	X	O	X	O
SET MULTIPLE MODE	C6h	O	X	X	O	X	X
SLEEP	E6h	X	X	X	O	X	X
SMART	B0h	X	X	O	O	X	O
STANDBY	E2h	X	X	X	O	X	X
STANDBY IMMEDIATE	E0h	X	X	X	O	X	X
WRITE BUFFER	E8h	X	X	X	O	X	X
WRITE DMA	CAh or CBh	O	O	O	O	O	X
WRITE DMA EXT	35h	O	O	O	O	O	X
WRITE DMA FUA EXT	3Dh	O	O	O	O	O	X
WRITE FPDMA QUEUED	61h	O	O	O	O	O	O
WRITE MULTIPLE	C5h	O	O	O	O	O	X
WRITE MULTIPLE EXT	39h	O	O	O	O	O	X
WRITE MULTIPLE FUA EXT	CEh	O	O	O	O	O	X
WRITE SECTOR(S)	30h or 31h	O	O	O	O	O	X
WRITE SECTOR(S) EXT	34h	O	O	O	O	O	X

Note:

O = Valid, X = Don't care

SC = Sector Count Register

SN = Sector Number Register

CY = Cylinder Low/High Register

DR = DEVICE SELECT Bit (DEVICE/HEAD Register Bit 4)

HD = HEAD SELECT Bit (DEVICE/HEAD Register Bit 3-0)

FT = Features Register

TS8GSSD25S-Si
TS16GSSD25S-Si

TS32GSSD25S-Si
TS64GSSD25S-Si



2.5" Industrial Wide Temp.
SATA II Solid State Disk

Identify Device Information Default Value

Word	Value	F/V	Description
0	0040h	F X X X V X	General configuration bit-significant information: 15 0 = ATA device 14-8 Retired 7-6 Obsolete 5-3 Retired 2 Reserved 1 Retired 0 Reserved
1	3C8Ah 3FFFh	F	Number of logical cylinders 15498 (8GB capacity) 16383 (above 16GB capacity)
2	C837h	V	Specific configuration
3	0010h	F	Number of logical heads
4-5	0000h	X	Retired
6	003Fh	F	Number of logical sector per logical track
7-8	0000h		Reserved for assignment by the CompactFlash_ Association
9	0000h	X	Retired
10-19	XXXXh	F	Serial number (20 ASCII characters)
20-21	0000h	X	Retired
22	0000h	X	Obsolete
23-26	XXXXh	F	Firmware revision (8 ASCII characters)
27-46	XXXXh	F	Model number (40 ASCII characters)
47	8001h	F F F	15-8 80h 7-0 00h = Reserved 01h = Maximum number of 1 sectors on READ/WRITE MULTIPLE commands
48	0000h	F	Reserved
49	2F00h	F F F F F X	Capabilities 15-14 Reserved for the IDENTIFY PACKET DEVICE command. 13 1 = Standby timer values as specified in this standard are supported 0 = Standby timer values shall be managed by the device 12 Reserved for the IDENTIFY PACKET DEVICE command. 11 1 = IORDY supported 0 = IORDY may be supported 10 1 = IORDY may be disabled 9 1 = LBA supported 8 1 = DMA supported. 7-0 Retired

TS8GSSD25S-Si
TS16GSSD25S-Si

TS32GSSD25S-Si
TS64GSSD25S-Si



2.5" Industrial Wide Temp.
SATA II Solid State Disk

50	4000h	F	Capabilities
		F	15 Shall be cleared to zero.
		F	14 Shall be set to one.
		X	13-2 Reserved.
		F	1 Obsolete
		F	0 Shall be set to one to indicate a device specific Standby timer value minimum.
51	0000h	F	15-8 PIO data transfer cycle timing mode
			7-0 Reserved
52	0000h	X	Obsolete
53	0007h	F	15-3 Reserved
		F	2 1 = the fields reported in word 88 are valid 0 = the fields reported in word 88 are not valid
		F	1 1 = the fields reported in words 70:64 are valid 0 = the fields reported in words 70:64 are not valid
		X	0 1 = the fields reported in words 58:54 are valid 0 = the fields reported in words 58:54 are not valid
54	XXXXh	X	Number of current cylinders
55	00XXh	X	Number of current heads
56	XXXXh	X	Number of current sector per track
57-58	XXXXh	X	Current capacity in sectors
59	0101h	V	15-9 Reserved
		V	8 1 = Multiple sector setting is valid
		V	7-0 xxh = Setting for number of sectors that shall be transferred per interrupt on R/W Multiple command
60-61	XXXXh	F	Total number of user addressable sectors
62	0000h	X	Obsolete
63	0007h	F	15-11 Reserved
		V	10 1 = Multiword DMA mode 2 is selected 0 = Multiword DMA mode 2 is not selected
		V	9 1 = Multiword DMA mode 1 is selected 0 = Multiword DMA mode 1 is not selected
		V	8 1 = Multiword DMA mode 0 is selected 0 = Multiword DMA mode 0 is not selected
			7-3 Reserved
		F	2 1 = Multiword DMA mode 2 and below are supported
		F	1 1 = Multiword DMA mode 1 and below are supported
		F	0 1 = Multiword DMA mode 0 is supported
64	0003h	F	15-8 Reserved
			7-0 Advanced PIO modes supported
65	0078h	F	Minimum Multiword DMA transfer cycle time per word
66	0078h	F	Manufacturer's recommended Multiword DMA transfer cycle time
67	0078h	F	Minimum PIO transfer cycle time without flow control
68	0078h	F	Minimum PIO transfer cycle time with IORDY flow control
69-70	0000h		Reserved

TS8GSSD25S-Si
TS16GSSD25S-Si

TS32GSSD25S-Si
TS64GSSD25S-Si



2.5" Industrial Wide Temp.
SATA II Solid State Disk

71-74	0000h		Reserved for the IDENTIFY PACKET DEVICE command
75	0000h	F	Queue depth 15-5 Reserved 4-0 Maximum queue depth – 1
76	0106h	F F F F F F F	Serial ATA Capabilities 15-11 Reserved for Serial ATA 10 1 = Supports Phy Event Counts 9 1 = Supports receipt of host initiated power management requests 8 1 = Supports the NCQ feature set 7-3 Reserved for Serial ATA 2 1 = Supports SATA Gen2 Signaling Speed (3.0Gb/s) 1 1 = Supports SATA Gen1 Signaling Speed (1.5Gb/s) 0 Shall be cleared to zero
77	0000h		Reserved for Serial ATA
78	0004h	F F F F F F	Serial ATA feature supported 15-7 Reserved for Serial ATA 6 1 = Device supports Software Settings Preservation 5 Reserved for Serial ATA 4 1 = Device supports in-order data delivery 3 1 = Device supports initiating power management 2 1 = Device supports DMA Setup auto-activation 1 1 = Device supports non-zero buffer offsets 0 Shall be cleared to zero
79	0000h	V V V V V F	Serial ATA feature enabled 15-7 Reserved for Serial ATA 6 1 = Software Settings Preservation enabled 5 Reserved for Serial ATA 4 1 = In-order data delivery enabled 3 1 = Device initiated power management enabled 2 1 = DMA Setup auto-activation enabled 1 1 = Non-zero buffer offsets enabled 0 Shall be cleared to zero

TS8GSSD25S-Si
TS16GSSD25S-Si

TS32GSSD25S-Si
TS64GSSD25S-Si



2.5" Industrial Wide Temp.
SATA II Solid State Disk

80	00F0h		Major version number 0000h or FFFFh = device does not report version
		F	15 Reserved
		F	14 Reserved for ATA/ATAPI-14
		F	13 Reserved for ATA/ATAPI-13
		F	12 Reserved for ATA/ATAPI-12
		F	11 Reserved for ATA/ATAPI-11
		F	10 Reserved for ATA/ATAPI-10
		F	9 Reserved for ATA/ATAPI-9
		F	8 Reserved for ATA/ATAPI-8
		F	7 1 = supports ATA/ATAPI-7
		F	6 1 = supports ATA/ATAPI-6
		F	5 1 = supports ATA/ATAPI-5
		F	4 1 = supports ATA/ATAPI-4
		F	3 Obsolete
		X	2 Obsolete
		X	1 Obsolete
	0 Reserved		
81	0000h	F	Minor version number
82	304Bh		Command and feature sets supported
		X	15 Obsolete
		F	14 1 = NOP command supported
		F	13 1 = READ BUFFER command supported
		F	12 1 = WRITE BUFFER command supported
		X	11 Obsolete
		F	10 1 = Host Protected Area feature set supported
		F	9 1 = DEVICE RESET command supported
		F	8 1 = SERVICE interrupt supported
		F	7 1 = release interrupt supported
		F	6 1 = look-ahead supported
		F	5 1 = write cache supported
		F	4 Shall be cleared to zero to indicate that the PACKET Command feature set is not supported.
		F	3 1 = mandatory Power Management feature set supported
		F	2 1 = Removable Media feature set supported
		F	1 1 = Security Mode feature set supported
F	0 1 = SMART feature set supported		

TS8GSSD25S-Si
TS16GSSD25S-Si

TS32GSSD25S-Si
TS64GSSD25S-Si



2.5" Industrial Wide Temp.
SATA II Solid State Disk

83	7400h	F 15 F 14 F 13 F 12 F 11 F 10 F 9 F 8 7 F 6 F 5 F 4 F 3 F 2 F 1 F 0	Command and feature sets supported 15 Shall be cleared to zero 14 Shall be set to one 13 1 = The FLUSH CACHE EXT command is supported 12 Shall be set to one to indicate that the mandatory FLUSH CACHE command is supported 11 1 = The DCO feature set is supported 10 1 = The 48-bit Address feature set is supported 9 1 = The AAM feature set is supported 8 1 = SET MAX security extension supported 7 Reserved 6 1 = SET FEATURES subcommand required to spinup after power-up 5 1 = Power-Up In Standby feature set supported 4 1 = Removable Media Status Notification feature set supported 3 1 = Advanced Power Management feature set supported 2 1 = CFA feature set supported 1 1 = READ/WRITE DMA QUEUED supported 0 1 = DOWNLOAD MICROCODE command supported
84	4060h	F 15 F 14 F 13 12-11 X 10-9 F 8 F 7 F 6 F 5 F 4 F 3 F 2 F 1 F 0	Command and feature sets supported 15 Shall be cleared to zero 14 Shall be set to one 13 1 = The IDLE IMMEDIATE command with UNLOAD feature is supported 12-11 Reserved for TLC 10-9 Obsolete 8 1 = The 64-bit World wide name is supported 7 1 = The WRITE DMA QUEUED FUA EXT command is supported 6 1 = The WRITE DMA FUA EXT and WRITE MULTIPLE FUA EXT commands are supported 5 1 = The GPL feature set is supported 4 1 = The Streaming feature set is supported 3 1 = The Media Card Pass Through Command feature set is supported 2 1 = Media serial number is supported 1 1 = SMART self-test supported 0 1 = SMART error logging supported
85	3069h	X 15 F 14 F 13 F 12 X 11 V 10 F 9 V 8 V 7 V 6 V 5 F 4 F 3 X 2 V 1 V 0	Command and feature sets supported or enable (Depend on the host enabling) 15 Obsolete 14 1 = The NOP command is supported 13 1 = The READ BUFFER command is supported 12 1 = The WRITE BUFFER command is supported 11 Obsolete 10 1 = HPA feature set is supported 9 Shall be cleared to zero to indicate that the DEVICE RESET command is not supported 8 1 = The SERVICE interrupt is enabled 7 1 = The release interrupt is enabled 6 1 = Read look-ahead is enabled 5 1 = The volatile write cache is enabled 4 Shall be cleared to zero to indicate that the PACKET Command feature set is not supported. 3 Shall be set to one to indicate that the mandatory Power Management feature is supported 2 Obsolete 1 1 = The Security feature set is enabled 0 1 = The SMART feature set is enabled

TS8GSSD25S-Si
TS16GSSD25S-Si

TS32GSSD25S-Si
TS64GSSD25S-Si



2.5" Industrial Wide Temp.
SATA II Solid State Disk

86	3400h	F 15 F 14 F 13 F 12 F 11 F 10 V 9 V 8 F 7 V 6 V 5 X 4 V 3 F 2 F 1 F 0	Command and feature sets supported or enable (Depend on the host enabling) 15 1 = Words 119-120 are valid 14 Reserved 13 1 = FLUSH CACHE EXT command supported 12 1 = FLUSH CACHE command supported 11 1 = The DCO feature set is supported 10 1 = The 48-bit Address feature set is supported 9 1 = The AAM feature set is enable 8 1 = The SET MAX security extension is enabled by SET MAX SET PASSWORD 7 Reserved for Address Offset Reserved Area Boot Method 6 1 = SET FEATURES subcommand required to spin-up after power-up 5 1 = The PUIS feature set is enabled 4 Obsolete 3 1 = The APM feature set is enabled 2 1 = The CFA feature set is supported 1 1 = The TCQ feature set is supported 0 1 = The DOWNLOAD MICROCODE command is supported
87	4060h	F 15 F 14 F 13 X 12-11 X 10-9 F 8 F 7 F 6 F 5 X 4 V 3 V 2 F 1 F 0	Command and feature sets supported or enabled (Depend on the host enabling) 15 Shall be cleared to zero 14 Shall be set to one 13 1 = The IDLE IMMEDIATE command with UNLOAD feature is supported 12-11 Reserved for TLC 10-9 Obsolete 8 1 = The 64-bit World wide name is supported 7 1 = The WRITE DMA QUEUED FUA EXT command is supported 6 1 = The WRITE DMA FUA EXT and WRITE MULTIPLE FUA EXT commands are supported 5 1 = The GPL feature set is supported 4 Obsolete 3 1 = The Media Card Pass Through Command feature set is supported 2 1 = Media serial number is supported 1 1 = SMART self-test supported 0 1 = SMART error logging supported

TS8GSSD25S-Si
TS16GSSD25S-Si

TS32GSSD25S-Si
TS64GSSD25S-Si



2.5" Industrial Wide Temp.
SATA II Solid State Disk

88	XX7Fh	V	Ultra DMA modes (XX depends on the host selecting)
			15 Reserved
		V	14 1 = Ultra DMA mode 6 is selected 0 = Ultra DMA mode 6 is not selected
		V	13 1 = Ultra DMA mode 5 is selected 0 = Ultra DMA mode 5 is not selected
		V	12 1 = Ultra DMA mode 4 is selected 0 = Ultra DMA mode 4 is not selected
		V	11 1 = Ultra DMA mode 3 is selected 0 = Ultra DMA mode 3 is not selected
		V	10 1 = Ultra DMA mode 2 is selected 0 = Ultra DMA mode 2 is not selected
		V	9 1 = Ultra DMA mode 1 is selected 0 = Ultra DMA mode 1 is not selected
		V	8 1 = Ultra DMA mode 0 is selected 0 = Ultra DMA mode 0 is not selected
			7 Reserved
		F	6 1 = Ultra DMA mode 6 and below are supported
		F	5 1 = Ultra DMA mode 5 and below are supported
		F	4 1 = Ultra DMA mode 4 and below are supported
		F	3 1 = Ultra DMA mode 3 and below are supported
		F	2 1 = Ultra DMA mode 2 and below are supported
		F	1 1 = Ultra DMA mode 1 and below are supported
F	0 1 = Ultra DMA mode 0 is supported		
89	0001h	F	15-8 Reserved 7-0 Time required for Normal Erase mode SECURITY ERASE UNIT command
90	0001h	F	15-8 Reserved 7-0 Time required for Enhanced Erase mode SECURITY ERASE UNIT command
91	0000h	V	Current APM level value
92	FFFEh	V	Master Password Identifier
93	0000h	X	Hardware reset result
94	0000h	F	Current AAM value
		V	15-8 Vendor's recommended AAM value 7-0 Current AAM value
95-99	0000h		Reserved
100-103	XXXXh	X	Total Number of User Addressable Logical Sectors for 48-bit commands (QWord)
104-105	0000h		Reserved
106	4000h	F	Physical sector size / logical sector size
		F	15 Shall be cleared to zero
		F	14 Shall be set to one
		F	13 1 = Device has multiple logical sectors per physical sector
		F	12 1 = Device Logical Sector longer than 256 Words
		F	11-4 Reserved
F	3-0 2x logical sectors per physical sector		
107-118	0000h		Reserved

TS8GSSD25S-Si
TS16GSSD25S-Si

TS32GSSD25S-Si
TS64GSSD25S-Si



2.5" Industrial Wide Temp.
SATA II Solid State Disk

119	4000h	F F F F F F F 0	Commands and feature sets supported (Continued from words 84:82) 15 Shall be cleared to zero 14 Shall be set to one 13-6 Reserved 5 1= The Free-fall Control feature set is supported 4 1 = The DOWNLOAD MICROCODE command with mode 3 is supported 3 1 = The READ LOG DMA EXT and WRITE LOG DMA EXT commands are supported 2 1 = The WRITE UNCORRECTABLE EXT command is supported 1 1 = The Write-Read-Verify feature set is supported 0 Reserved for DDT
120	4000h	F F V F F F V 0	Commands and feature sets supported or enabled (Continued from words 87:85) 15 Shall be cleared to zero 14 Shall be set to one 13-6 Reserved 5 1= The Free-fall Control feature set is enabled 4 1 = The DOWNLOAD MICROCODE command with mode 3 is supported 3 1 = The READ LOG DMA EXT and WRITE LOG DMA EXT commands are supported 2 1 = The WRITE UNCORRECTABLE EXT command is supported 1 1 = The Write-Read-Verify feature set is enabled 0 Reserved for DDT
121-126	0000h		Reserved for expended supported and enabled settings
127	0000h	X	Obsolete
128	0021h	F V F F V V V V V F 0	Security status 15-9 Reserved 8 Security level 0 = High, 1 = Maximum 7-6 Reserved 5 1 = Enhanced security erase supported 4 1 = Security count expired 3 1 = Security frozen 2 1 = Security locked 1 1 = Security enabled 0 1 = Security supported
129-159	0000h	X	Vendor specific
160-216	0000h		Reserved
217	0001h	F	Nominal media rotation rate
218-254	0000h		Reserved
255	0000h	X	Integrity word 15-8 Checksum 7-0 Signature

Key:

F/V = Fixed/variable content

F = the content of the word is fixed and does not change. For removable media devices, these values may change when media is removed or changed.

V = the contents of the word is variable and may change depending on the state of the device or the commands executed by the device.

TS8GSSD25S-Si
TS16GSSD25S-Si

TS32GSSD25S-Si
TS64GSSD25S-Si



2.5" Industrial Wide Temp.
SATA II Solid State Disk

X = the content of the word may be fixed or variable.

SMART Data Structure

ID	Description	Detail Information	
		Byte	Description
E5h	Halt System ID, Flash ID	0	Halt System ID
		1	Flash ID (byte 1)
		2	Flash ID (byte 2)
		3	Flash ID (byte 3)
		4	Flash ID (byte 4)
		5	Flash ID (byte 5)
		6	Flash ID (byte 6)
		7	Flash ID (byte 7)
E8h	Firmware version information	0	Year (High Byte, ASCII)
		1	Year (Low Byte, ASCII)
		2	Month (High Byte, ASCII)
		3	Month (Low Byte, ASCII)
		4	Day (High Byte, ASCII)
		5	Day (Low Byte, ASCII)
		6	Channels (binary)
		7	Banks (binary)
E9h	ECC Fail Record	0	ECC fail number
		1	Row address 3
		2	Row address 2
		3	Row address 1
		4	Channel number of last ECC fail
		5	Bank number of last ECC fail
		6	Reserved
		7	Reserved

TS8GSSD25S-Si
TS16GSSD25S-Si

TS32GSSD25S-Si
TS64GSSD25S-Si



2.5" Industrial Wide Temp.
SATA II Solid State Disk

EAh	Average Erase Count, Max Erase Count	0	Average Erase Count (High Byte)
		1	Average Erase Count
		2	Average Erase Count (Low Byte)
		3	Max Erase Count (High Byte)
		4	Max Erase Count
		5	Max Erase Count (Low Byte)
		6	Reserved
		7	Reserved
EBh	Good Block Count, System Block Count	0	Good Block Count (High Byte)
		1	Good Block Count
		2	Good Block Count (Low Byte)
		3	System(Free) Block Count (High
		4	Byte)
		5	System(Free) Block Count (Low
		6	Byte)
		7	Reserved
			Reserved
			Reserved
ECh-FFh	Reserved		



TS8GSSD25S-Si
TS16GSSD25S-Si

TS32GSSD25S-Si
TS64GSSD25S-Si

2.5" Industrial Wide Temp.
SATA II Solid State Disk

Ordering Information

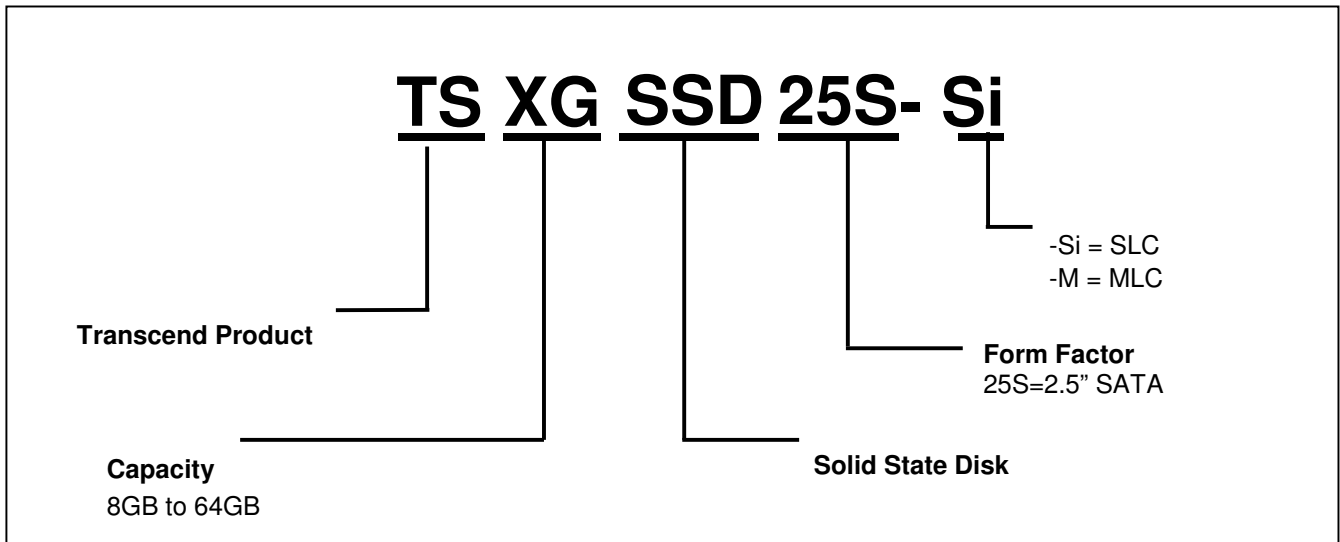

The above technical information is based on industry standard data and has been tested to be reliable. However, Transcend makes no warranty, either expressed or implied, as to its accuracy and assumes no liability in connection with the use of this product. Transcend reserves the right to make changes to the specifications at any time without prior notice.



TAIWAN

No.70, XingZhong Rd., NeiHu Dist., Taipei, Taiwan, R.O.C
TEL +886-2-2792-8000
Fax +886-2-2793-2222
E-mail: sales@transcend.com.tw
www.transcend.com.tw

USA

Los Angeles:

E-mail: sales@transcendusa.com

Maryland:

E-mail: sales_md@transcendusa.com

www.transcendusa.com

CHINA

E-mail: sales@transcendchina.com

www.transcendchina.com

GERMANY

E-mail: vertrieb@transcend.de

www.transcend.de

HONG KONG

E-mail: sales@transcend.com.hk

www.transcend.com.hk

JAPAN

E-mail: sales@transcend.co.jp

www.transcend.jp

THE NETHERLANDS

E-mail: sales@transcend.nl

www.transcend.nl

United Kingdom

E-mail: sales@transcend-uk.com

www.transcend-uk.com

KOREA

E-mail: sales@transcend.co.kr

www.transcend.co.kr

TS8GSSD25S-Si
TS16GSSD25S-Si

TS32GSSD25S-Si
TS64GSSD25S-Si



2.5" Industrial Wide Temp.
SATA II Solid State Disk

Revision History			
Version	Date	Modification Content	Modified Page
V1.0	2011/7/15	Initial release	
V1.1	2011/8/18	Modified Package Dimension	5