

Panasonic
ideas for life

**COMPACT ECONOMICAL
30 AMP. RELAY**

**JT-N
RELAYS**



PCB type



TMP type

FEATURES

- High switching capacity — 30 A for 1 Form A
- 2 contact arrangements — 1 Form A or 1 Form C
- “TMP” types available
- UL/CSA recognized
- Class F types standard

SPECIFICATIONS

Contacts

		PCB & TMP type	
Arrangement		1 Form A	1 Form C
Initial contact resistance, max. (By voltage drop method, 6 V DC 1 A)		50 mΩ	
Contact material		Silver alloy	
Rating	Max. switching power	8310 VA	N.C.: 2770 VA N.O.: 5540 VA
	Max. switching voltage	277 V AC	
	Max. switching current	30 A	N.C.: 10 A N.O.: 20 A
	Min. switching capacity* ^{#1}	100 mA, 5 V DC	
Expected life	Mechanical	Min. 1×10 ⁷	
	Electrical (Resistive load)	20 A 277 V AC Min. 1×10 ⁵ *	N.O.: 20 A 277 V AC Min. 1×10 ⁵ * N.C.: 10 A 277 V AC Min. 1×10 ⁵ *

* The life is for open venting-hole condition.

Coil at 20°C 68°F

Nominal operating power	Approx. 800 mW
-------------------------	----------------

Characteristics

		PCB & TMP type	
Initial insulation resistance* ^{#1}		Min. 100 MΩ at 500 V DC	
Initial breakdown voltage* ^{#2}	Between contacts	1,200 Vrms	
	Between contacts and coil	2,500 Vrms	
Operate time* ^{#3} (at nominal voltage)		Max. 20 ms	
Release time (without diode)* ^{#3} (at nominal voltage)		Max. 10 ms	
Shock resistance	Functional* ^{#4}	Min. 98 m/s ² {10 G}	
	Destructive* ^{#5}	Min. 980 m/s ² {100 G}	
Vibration resistance	Functional* ^{#6}	Max. 88.2 m/s ² {9 G}, 10 to 55 Hz at double amplitude of 1.5 mm	
	Destructive	Max. 117.6 m/s ² {12 G}, 10 to 55 Hz at double amplitude of 2 mm	
Conditions for operation, transport and storage* ^{#7} (Not freezing and condensing at low temperature)	Ambient temp.	-55°C to +85°C -67°F to +185°F	
	Humidity	5 to 85% R.H.	
Unit weight		PCB type: Approx. 25 g (.88 oz) TMP type: Approx. 30 g (1.06 oz)	

#1 This value can change due to the switching frequency, environmental conditions, and desired reliability level, therefore it is recommended to check this with the actual load.

Remarks

- * Specifications will vary with foreign standards certification ratings.
- *^{#1} Measurement at same location as “Initial breakdown voltage” section
- *^{#2} Detection current: 10 mA
- *^{#3} Excluding contact bounce time
- *^{#4} Half-wave pulse of sine wave: 11ms; detection time: 10μs
- *^{#5} Half-wave pulse of sine wave: 6ms
- *^{#6} Detection time: 10μs
- *^{#7} Refer to 6. Conditions for operation, transport and storage mentioned in AMBIENT ENVIRONMENT (see catalog).

TYPICAL APPLICATIONS

- Automotive
- Air conditioner
- Heating & ventilation
- Home appliance

ORDERING INFORMATION

JT-N Relays (PCB and TMP type)

JTN		1a	S	TMP	F	DC12V
Contact arrangement	Protective construction	Mounting classification	Coil insulation	Coil voltage		
1a: 1 Form A 1: 1 Form C	S: Sealed type	PA: PCB type TMP: TMP type	F: Class F	DC 5, 6, 9, 12, 15, 18, 24 V		

Notes: 1. UL/CSA approved type is standard.
2. Standard packing: PCB type: Carton: 50 pcs. Case: 500 pcs.
TMP type: Carton: 50 pcs. Case: 300 pcs.

COIL DATA (at 20°C 68°F)

Nominal voltage, V DC	Pick-up voltage, V DC (max.) (Initial)	Drop-out voltage, V DC (min.) (Initial)	Coil resistance, Ω (±10%)		Nominal operating power, mW		Max. allowable voltage, V DC (at 70°C 158°F)
			PCB & TMP	PCB & TMP	PCB & TMP	PCB & TMP	
5	3.75	0.5	31	800	6		
6	4.5	0.6	45	800	7.2		
9	6.75	0.9	101	800	10.8		
12	9.0	1.2	180	800	14.4		
15	11.25	1.5	281	800	18		
18	13.5	1.8	405	800	21.6		
24	18.0	2.4	720	800	28.8		

DIMENSIONS

mm inch

1. PCB type
1 Form A

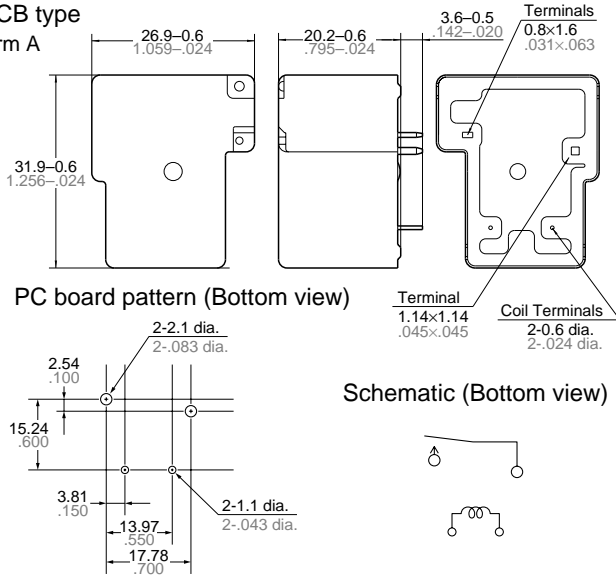

1 Form C

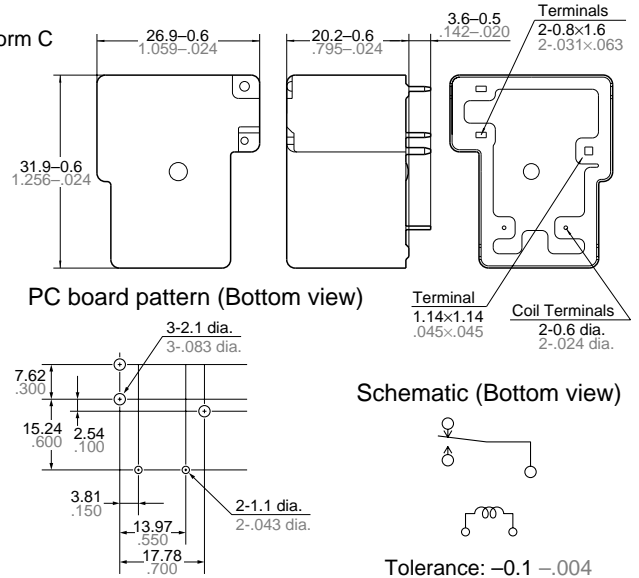

2. TMP type
1 Form A

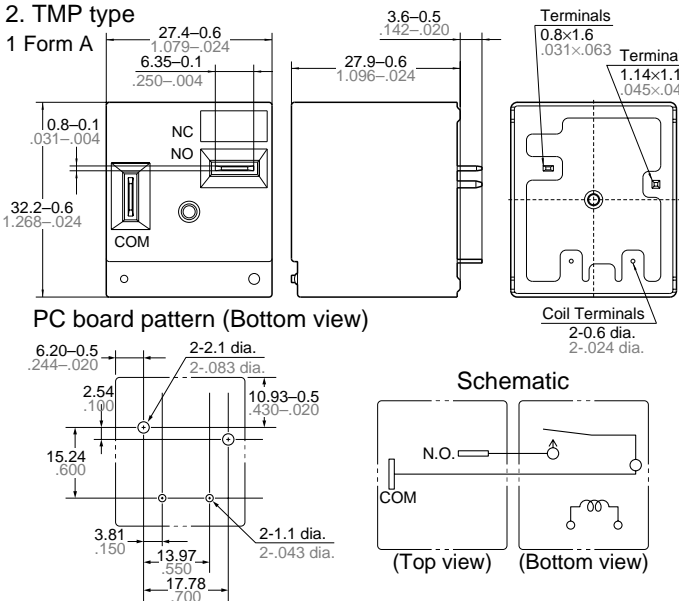

1 Form C

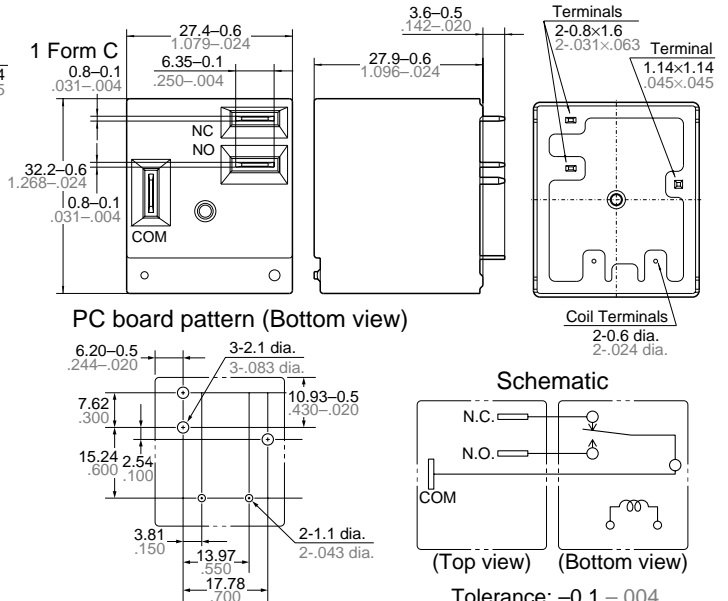

REFERENCE DATA

1. Change of rate of pick-up and drop-out voltage (at 20°C 68°F)
 Sample: JTN1S-TMP-F-DC24V (6 pcs.)

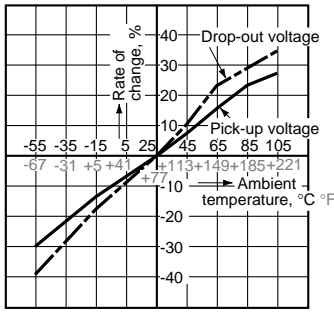

2. Operate & release time (at 20°C 68°F)
 Sample: JTN1S-TMP-F-DC24V (6 pcs.)

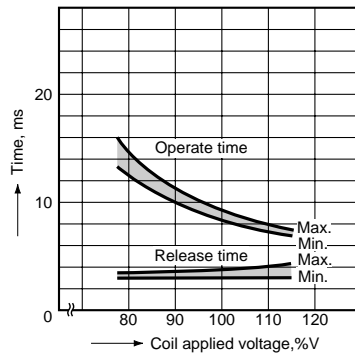

3. Operate & release time (at 20°C 68°F)
 Sample: JTN1aS-PA-F-DC24V (6 pcs.)

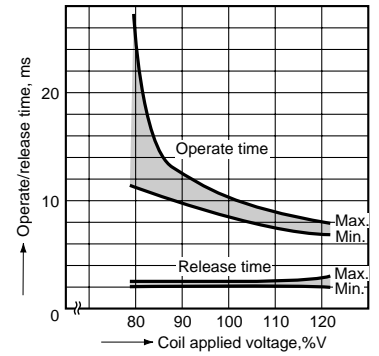

4. Distribution frequency of pick-up voltage (at 20°C 68°F)
 Sample: JTN1S-TMP-F-DC12V (30 pcs.)

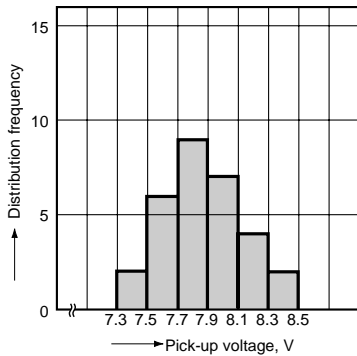

5. Distribution frequency of drop-out voltage (at 20°C 68°F)
 Sample: JTN1S-TMP-F-DC12V (30 pcs.)

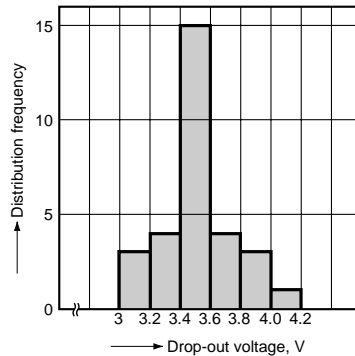

6.-(1) Coil temperature rise (TMP type)*
 Ambient temperature: 20°C 68°F
 Sample: JTN1aS-TMP-F-DC12V (6 pcs.)

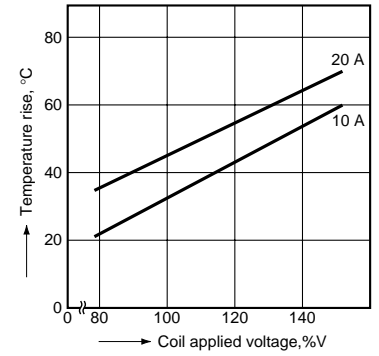

* Coil temperature rise of sealed types are same as data of the dust cover type.

Ambient temperature: 55°C 131°F
 Sample: JTN1aS-TMP-F-DC12V (6 pcs.)

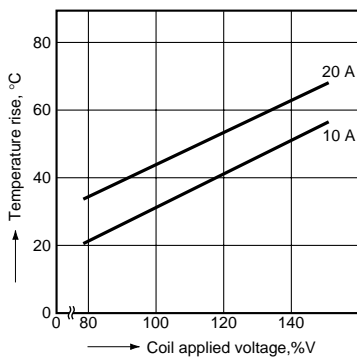

Ambient temperature: 85°C 185°F
 Sample: JTN1aS-TMP-F-DC12V (6 pcs.)

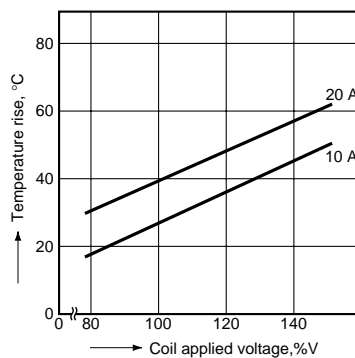

Ambient temperature: 105°C 221°F
 Sample: JTN1aS-TMP-F-DC12V (6 pcs.)

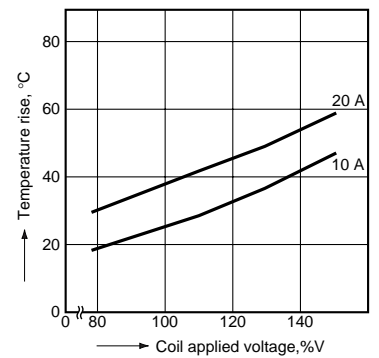

For Cautions for Use, see Relay Technical Information (see catalog).