

DATASHEET

ITEM: 35221FR

WHEEL AS 150X40/50 CRX SPG X20 +FR

WHEEL SERIE

Wheels with cast soft polyurethane coating 87 Sh.A on polyamide 6 center.

Wheel fitted with stainless steel roller bearing.

FORK DESCRIPTION

Inox20 series, polished stainless steel forks, swivels with double ball races.

Trailing foot brake - total stop.



TECHNICAL DETAILS

Wheel diameter	(D)	150 mm
Tyre width	(E)	40 mm
Bore diameter	(d)	20 mm
Reference weight		1,672 kg
Overall height	(H)	181 mm
Top plate outer dimensions	(AxB)	135x110 mm
Bolt hole spacing	(axb)	96x56 mm
Bolt hole spacing	(axb)	105x75 mm
Bolt hole spacing	(axb)	105x80 mm
Fixing bolt diameter	(g)	10 mm
Offset	(F)	51 mm
Fork width	(U)	50 mm
Load capacity		250 kg

Possible options :

Wheel replacement	35071X
Brake	FR

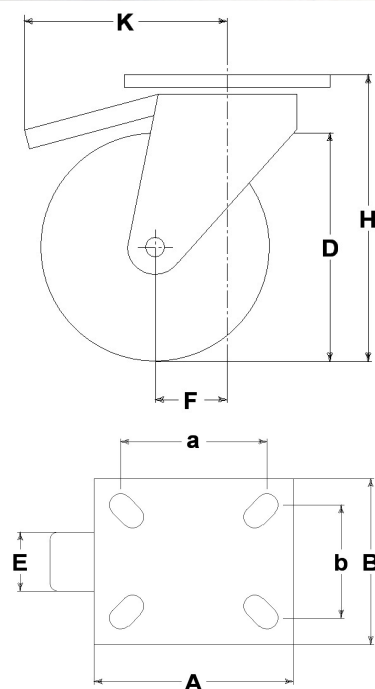

GENERAL INFORMATION / RECOMMENDATIONS AND WARNINGS

The cited text and the complete catalogue in their most up-dated versions are available in our web-site www.lagspa.eu/web/downloads. The dimensions, descriptions, specifications and illustrations herein are indicative and subject to variations without notice. The fact that products are illustrated herein does not necessarily imply they are available from stock nor does it place us under any obligation to supply them. Tests carried out refer to the original products with original accessories: the replacement of one of the components with others of different manufacture might prevent the same results from being achieved and will automatically invalidate any guarantee. Please contact our technical service concerning any special application.