

SPECIFICATIONS	
CONTACT CARRIER MATERIAL/COLOR	NYLON OR TPU/BLACK
CONTACT MATERIAL/PLATING	BRASS/GOLD
HOUSING/LOCKNUT MATERIAL/PLATING	BRASS/NICKEL
O-RING MATERIAL	BUNA-N
RATED CURRENT [A]	4.0 A
RATED VOLTAGE [V]	125 v
NUMBER OF CONDUCTORS [AWG]	PRINTED CIRCUIT PINS
TEMPERATURE RANGE	-30°C to +80°C (-22°F to +176°F)
PROTECTION CLASS	MEETS NEMA 1,3,4,6P AND IEC IP67

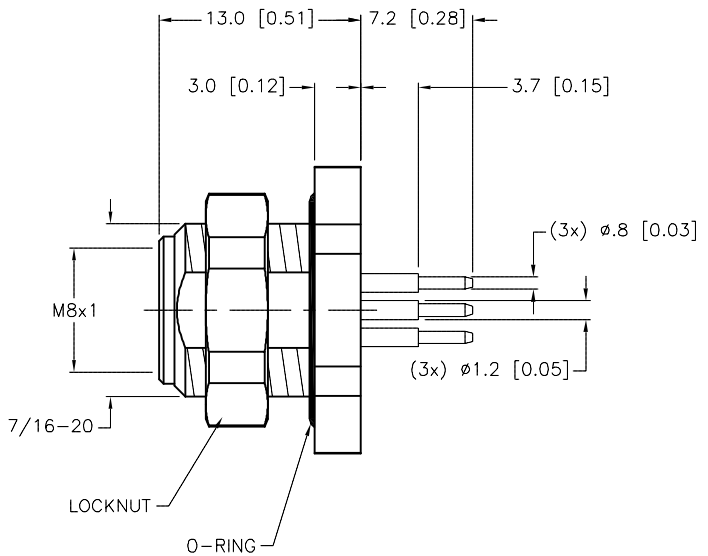
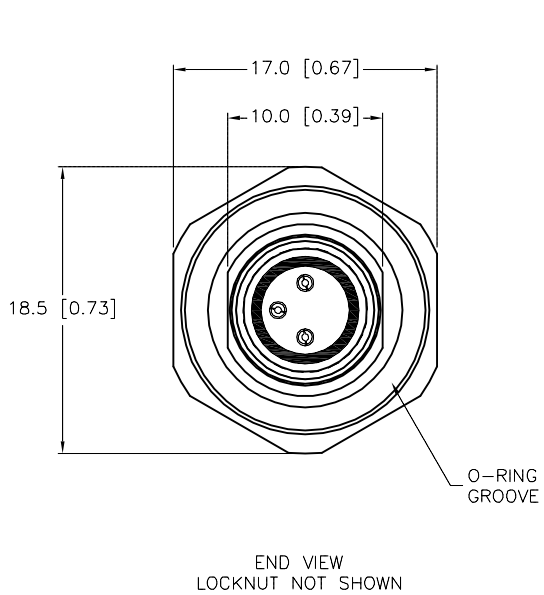
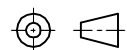

SOURCE DRAWING - FOR REFERENCE ONLY

NOTES:
1. NOTE HOW PINS ARE ORIENTED TO THE FLAT.

RELATED DOCUMENTS		3RD ANGLE PROJECTION		THIS DRAWING IS CONFIDENTIAL AND THE PROPERTY OF TURCK INC. USE OF THIS DOCUMENT WITHOUT WRITTEN PERMISSION IS PROHIBITED.		<p>3000 CAMPUS DRIVE MINNEAPOLIS, MN 55441 1-800-544-7769 (763) 553-7300 (763) 553-0708 fax turck.com</p>	
1. 2. 3. 4.				<p>DRFT RWC DATE 10/05/09</p> <p>APVD SCALE 1=.5</p>		DESCRIPTION MFKS 3F-PCB	
MATERIAL SEE SPECIFICATIONS		ALL DIMENSIONS DISPLAYED ON THIS DRAWING ARE FOR REFERENCE ONLY		UNIT OF MEASUREMENT MILLIMETER [INCH]		IDENTIFICATION NO. U2-16549	
FINISH SEE SPECIFICATIONS		CONTACT TURCK FOR MORE INFORMATION		DO NOT SCALE THIS DRAWING		REV E	
E ADD TYP. PANEL CUTOUT		RDS 06/19/14 46184		FILE: U2-16549		SHEET 1 OF 1	
REV DESCRIPTION		BY DATE ECO NO.					