

# MSO4000B and DPO4000B Series Digital Phosphor Oscilloscopes Service Manual



077-0512-00

**Tektronix**



# **MSO4000B and DPO4000B Series Digital Phosphor Oscilloscopes Service Manual**

This document applies to firmware version 1.00 and above.

## **Warning**

The servicing instructions are for use by qualified personnel only. To avoid personal injury, do not perform any servicing unless you are qualified to do so. Refer to all safety summaries prior to performing service.

[www.tektronix.com](http://www.tektronix.com)

077-0512-00

**Tektronix**

Copyright © Tektronix. All rights reserved. Licensed software products are owned by Tektronix or its subsidiaries or suppliers, and are protected by national copyright laws and international treaty provisions.

Tektronix products are covered by U.S. and foreign patents, issued and pending. Information in this publication supersedes that in all previously published material. Specifications and price change privileges reserved.

TEKTRONIX and TEK are registered trademarks of Tektronix, Inc.

## **Contacting Tektronix**

Tektronix, Inc.  
14150 SW Karl Braun Drive  
P.O. Box 500  
Beaverton, OR 97077  
USA

For product information, sales, service, and technical support:

- In North America, call 1-800-833-9200.
- Worldwide, visit [www.tektronix.com](http://www.tektronix.com) to find contacts in your area.

---

# Table of Contents

General Safety Summary .....	iv
Service Safety Summary .....	vi
Preface .....	vii
Manual Conventions.....	vii
Where to Find Operating Information .....	1
Theory of Operation .....	3
Power Supply.....	3
I/O Board .....	3
Main Board and Analog Board.....	3
Front-Panel Board .....	4
Adjustment Procedure.....	7
Required Equipment.....	7
Before Adjustments.....	8
Navigating During Adjustments .....	8
Connecting the Equipment.....	9
Factory Adjustment Procedure .....	10
Setting the Calibrator Output Signal.....	13
Maintenance .....	19
Preventing ESD .....	19
Inspection and Cleaning.....	19
Module Removal.....	23
Troubleshooting.....	25
Troubleshooting Procedure .....	25
Unpacking and Repacking Instructions .....	29
Replaceable Parts List.....	31
Parts Ordering Information .....	31
Using the Replaceable Parts List.....	32

## List of Figures

Figure 1: MSO4000B and DPO4000B series block diagram.....	5
Figure 2: Removing tabs from the front protective cover.....	23
Figure 3: Module locator .....	24
Figure 4: Primary troubleshooting procedure .....	26
Figure 5: AC power supply troubleshooting procedure.....	27
Figure 6: Module isolation troubleshooting procedure.....	28
Figure 7: Exploded view, Front Panel assembly .....	34
Figure 8: Display, Analog board, and Main board assembly .....	36
Figure 9: Rear chassis and connecting modules .....	38
Figure 10: External parts .....	39
Figure 11: Rear chassis, showing cables and connectors .....	40
Figure 12: Main board, showing cable and connectors .....	41

---

## List of Tables

Table 1: External inspection checklist.....	21
Table 2: Internal inspection checklist .....	21
Table 3: Parts list column descriptions.....	32
Table 4: Replaceable parts – Front Panel assembly .....	33
Table 5: Replaceable parts – Display, Analog board, and Main board .....	35
Table 6: Replaceable parts – Rear chassis and connecting modules .....	37
Table 7: Replaceable parts – external parts.....	39
Table 8: Replaceable parts – cable and connectors, rear chassis .....	40
Table 9: Replaceable parts – cable and connectors, Main board .....	41

## General Safety Summary

Review the following safety precautions to avoid injury and prevent damage to this product or any products connected to it.

To avoid potential hazards, use this product only as specified.

*Only qualified personnel should perform service procedures.*

### To Avoid Fire or Personal Injury

**Use proper power cord.** Use only the power cord specified for this product and certified for the country of use.

**Connect and disconnect properly.** Do not connect or disconnect probes or test leads while they are connected to a voltage source.

**Connect and disconnect properly.** De-energize the circuit under test before connecting or disconnecting the current probe.

**Ground the product.** This product is grounded through the grounding conductor of the power cord. To avoid electric shock, the grounding conductor must be connected to earth ground. Before making connections to the input or output terminals of the product, ensure that the product is properly grounded.

**Observe all terminal ratings.** To avoid fire or shock hazard, observe all ratings and markings on the product. Consult the product manual for further ratings information before making connections to the product.

Connect the probe reference lead to earth ground only.

Do not apply a potential to any terminal, including the common terminal, that exceeds the maximum rating of that terminal.

**Power disconnect.** The power cord disconnects the product from the power source. Do not block the power cord; it must remain accessible to the user at all times.

**Do not operate without covers.** Do not operate this product with covers or panels removed.

**Do not operate with suspected failures.** If you suspect that there is damage to this product, have it inspected by qualified service personnel.

**Avoid exposed circuitry.** Do not touch exposed connections and components when power is present.

**Do not operate in wet/damp conditions.**

**Do not operate in an explosive atmosphere.**

**Keep product surfaces clean and dry.**

**Provide proper ventilation.** Refer to the manual's installation instructions for details on installing the product so it has proper ventilation.

**Terms in This Manual** These terms may appear in this manual:



**WARNING.** *Warning statements identify conditions or practices that could result in injury or loss of life.*



**CAUTION.** *Caution statements identify conditions or practices that could result in damage to this product or other property.*

**Symbols and Terms on the Product**

These terms may appear on the product:

- DANGER indicates an injury hazard immediately accessible as you read the marking.
- WARNING indicates an injury hazard not immediately accessible as you read the marking.
- CAUTION indicates a hazard to property including the product.

The following symbol(s) may appear on the product:



CAUTION  
Refer to Manual



Protective Ground  
(Earth) Terminal



Chassis Ground



Standby

## Service Safety Summary

Only qualified personnel should perform service procedures. Read this *Service Safety Summary* and the *General Safety Summary* before performing any service procedures.

**Do Not Service Alone.** Do not perform internal service or adjustments of this product unless another person capable of rendering first aid and resuscitation is present.

**Disconnect Power.** To avoid electric shock, switch off the instrument power, then disconnect the power cord from the mains power.

**Use Care When Servicing With Power On.** Dangerous voltages or currents may exist in this product. Disconnect power, remove battery (if applicable), and disconnect test leads before removing protective panels, soldering, or replacing components.

To avoid electric shock, do not touch exposed connections.

---

# Preface

This service manual provides information that you need to troubleshoot, disassemble, and replace parts on the following Tektronix oscilloscopes:

MSO4104B	MSO4054B	MSO4034B
DPO4104B	DPO4054B	DPO4034B

## Manual Conventions

This manual uses certain conventions that you should become familiar with before performing service.

**Modules** Throughout this manual, any replaceable component, assembly, or part is referred to by the term *module*.

**Replaceable Parts** This manual refers to any field-replaceable assembly or mechanical part specifically by its name or generically as a replaceable part. In general, a replaceable part is any circuit board or assembly, such as the hard disk drive, or a mechanical part, such as the I/O port connectors, that is listed in the replaceable parts list.

**Safety** Symbols and terms related to safety appear in the *General Safety Summary*. Information for service procedures appears in both the *General Safety Summary* and the *Service Safety Summary*.



---

## Where to Find Operating Information

For information on installing and operating your DPO4000B or your MSO4000B Series Digital Phosphor Oscilloscope, refer to the Tektronix *MSO4000B Series and DPO4000B Series Digital Phosphor Oscilloscopes User Manual*, which was provided with your oscilloscope. This manual is also available, in 11 languages, at [www.tektronix.com/manuals](http://www.tektronix.com/manuals).



---

# Theory of Operation

This chapter describes the electrical operation of the oscilloscope to the module level. The block diagram shows the oscilloscope module interconnections. (See Figure 1 on page 5.)

## Power Supply

The Power Supply board converts AC line voltage to +12 V to power for all internal circuits.

## I/O Board

The I/O board contains USB ports, an Ethernet port (LAN), a VGA Video port, an AUX OUT BNC connector, and an EXT REF IN BNC connector.

## Main Board and Analog Board

The Main and Analog boards contain the following functions:

- |                           |  |
|---------------------------|--|
| <b>Acquisition System</b> | The Acquisition system begins with the analog signal path and ends with a digitized signal in memory. The signal enters a channel input, and then passes through an attenuator and preamplifier. The analog signal from each preamplifier goes through a digitizer, a time base controller, and then into acquisition memory. The analog signal from each preamplifier is also distributed to a trigger circuit. |
| <b>Trigger System</b>     | The Trigger system processes the analog signals from the preamplifiers and sends trigger information to the time-base controller. Advanced trigger functions are enabled only when the appropriate application modules and supporting software are installed.  |
| <b>Display System</b>     | The Display system combines live waveform data from acquisition memory with menus and text, and stores this information in display memory. It then uses this data to refresh the XGA display module (LCD).   |
| <b>Processor System</b>   | The Processor system contains a 460EX Power PC microprocessor that controls the entire instrument. The processor system also contains FLASH ROM, system RAM, and interfaces to USB ports and the Ethernet port.  |

### **Power Converter**

The Power Converter receives +12 V power and +5 V standby power from the main power supply and generates voltages for the analog and digital circuitry on the Main board. The front panel receives the +5 V standby power, and uses input from the power switch to turn the oscilloscope on and off.

### **Front-Panel Board**

The Front Panel board contains a microprocessor that reads the front-panel buttons and controls, and then sends this information to the processor system on the Main board. The Front Panel board also generates the probe compensation output signal and provides an interface to the application modules.

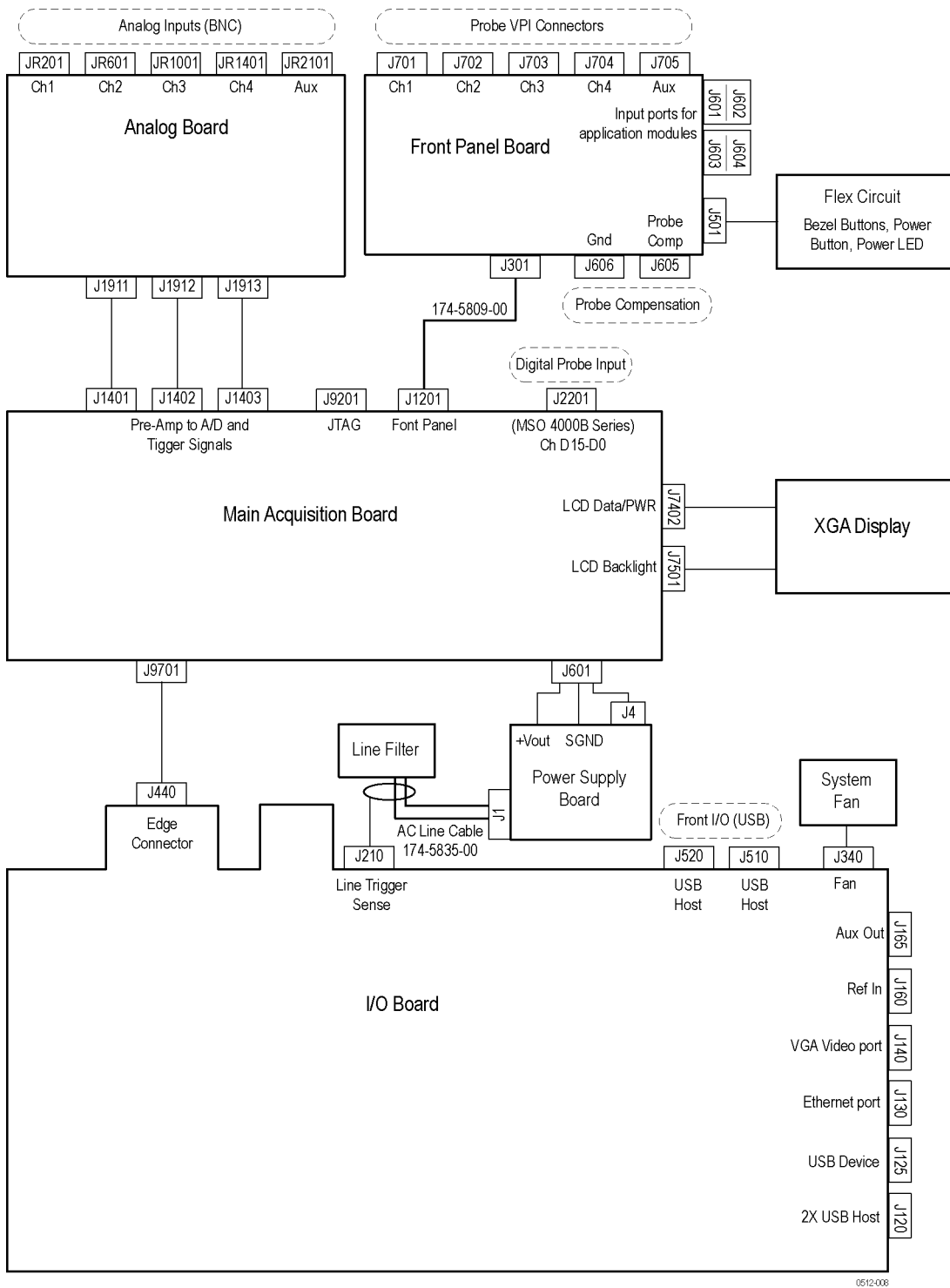

Figure 1: MSO4000B and DPO4000B series block diagram



# Adjustment Procedure

This section contains the factory adjustment procedure for the DPO4000B Series and the MSO4000B Series oscilloscopes. Only qualified personnel should perform adjustment procedures.

## Required Equipment

The following equipment, or a suitable equivalent, is required to complete these procedures.

The following table specifies the equipment that is required to adjust the DPO4000B Series oscilloscopes.

Description	Minimum requirements	Example
DC voltage source	20 mV to 100 V into 1 M $\Omega$ 6 V into 50 $\Omega$ $\pm 0.1\%$ amplitude accuracy	Fluke 9500B Oscilloscope Calibrator with 9530 active heads
Time Mark Generator	1.6 ms (625 Hz), 0.5 <sub>p-p</sub> symmetrical about 0 V into 50 $\Omega$ .	Fluke 9500B Oscilloscope Calibrator with one 9530 head
Sine Generator	Symmetrical about 0 V from 250 mV to 25 V into 1 M $\Omega$ . Aberrations <0.1% after 500 ns.	Fluke 9500B Oscilloscope Calibrator with one 9510 Output Module
Edge Generator	1 kHz with <50 ps ch-ch skew	
Adjustment tool	Nonconducting shaft with diameter = 0.1 in (= 2.5 mm)	Tektronix part number 003-1433-00

The following table specifies the equipment that is required to adjust the MSO4000B Series oscilloscopes.

Description	Minimum requirements	Example
DC voltage source	50 mV to 70 V $\pm 0.1\%$ amplitude accuracy	Fluke 9500B Oscilloscope Calibrator with five 9530 active heads
Digital calibrator probe		Tektronix part number: 067-2121-00

## Before Adjustments

---

**NOTE.** *The voltage references inside the oscilloscope are very stable over time and should not require routine adjustment.*

---

Before performing the adjustment procedure, do the following:

- Read the *Service Safety Summary* and the *General Safety Summary* at the front of this manual.
- Perform the Performance Verification procedures. If the oscilloscope is operating within specifications, you do not need to make any adjustments. (See the *MSO4000B Series and DPO4000B Series Oscilloscopes Specifications and Performance Verification Technical Reference manual*, which was provided with your product. This manual is also available at [www.tektronix.com/manuals](http://www.tektronix.com/manuals).)
- Before performing the adjustment procedure, you must warm up the oscilloscope and the oscilloscope calibrator for at least 30 minutes in an ambient temperature between 20 °C and 30 °C. Adjustments performed before warm-up or outside this temperature range may result in poor performance or failure of the adjustment procedure.
- Learn how to operate the oscilloscope calibrator. Refer to the user manual, which can be found at <http://us.fluke.com>.

## Navigating During Adjustments

- **Continue.** Once you have set the calibrator output signal that is specified on the oscilloscope screen, push the **OK Do Next Step** side-bezel button to proceed. Information about setting up the calibrator output signal is provided after the Factory Adjustment Procedure. (See page 13, *Setting the Calibrator Output Signal*.)
- **Go back.** Push the **Return to Previous Screen** side-bezel button to go back to the previous step. Push the button multiple times if you want to go back multiple steps.
- **Abort.** Push the **Menu Off** front-panel button on the oscilloscope to cancel the procedure at any time. This causes the oscilloscope to revert to the previous calibration constants. The *last factory calibration date* will not be updated.

## Connecting the Equipment

### Connect the Oscilloscope and the Calibrator to AC Power

Connect the oscilloscope and the calibrator to the same AC power circuit. Using a common power strip will accomplish this.

---

**NOTE.** *Connecting the equipment to separate AC power circuits can result in offset voltages between the equipment, which can invalidate this procedure.*

---

### Connect the Active Heads

Before beginning the adjustment procedure, connect four active heads from channels 1 through 4 on the calibrator to channels 1 through 4 on the oscilloscope. Make sure that Channel 1 on the calibrator connects to the Channel 1 input on the oscilloscope, and so on.

### Connect the Digital Probe (for MSO4000B Series Only)

When the oscilloscope prompt requires you to connect the calibrator signal to “all digital channels,” connect the digital probe as follows:

1. Plug the digital probe into the Channel 5 active head on the calibrator.
2. Plug the probe, notch down, into the digital channel input.
3. Make sure that it snaps into place. Keep the probe plugged in for the remainder of the calibration procedure.

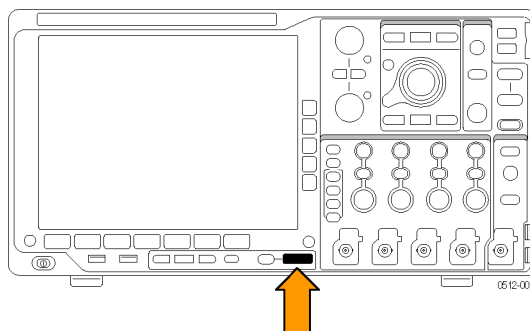

## Factory Adjustment Procedure

---

**NOTE.** Changing oscilloscope settings will abort the adjustment procedure. Do not turn any knobs or push any oscilloscope buttons except those used to navigate the procedure.

---

To perform the factory adjustment procedure, complete these steps:

1. Connect the oscilloscope and the calibrator to AC power. Be sure to follow the instructions provided in *Connecting the Equipment*. (See page 9, *Connecting the Equipment*.) Failure to follow these instructions can invalidate this procedure.
2. Power on the oscilloscope and the oscilloscope calibrator and allow them both to warm up for 30 minutes.
3. Connect the Active Heads, following the instructions provided in *Connecting the Equipment*. (See page 9, *Connecting the Equipment*.)
4. Put the oscilloscope into the service mode as follows (can take up to a minute):
  - a. Power off the oscilloscope.
  - b. Locate the hole in the rear panel that provides access to the CAL switch.

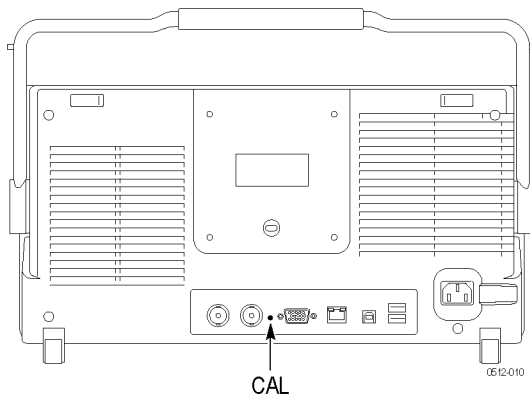

- c. Insert the adjustment tool into the CAL switch hole and power on the oscilloscope while holding in the switch.
  - d. Continue to hold the switch until the oscilloscope shows the "Power-on self- passed" message with the oscilloscope graticule in the background.
5. Start the factory adjustment routine as follows:
  - a. Push the **Default Setup** button on the front panel of the oscilloscope.
  - b. Push the **Utility** button on the front panel of the oscilloscope.
  - c. Push the **Utility Page** lower-bezel button.

- d. In the utility page menu, select **Calibration** by turning the **Multipurpose a** knob.
  - e. Push the **Factory** lower-bezel button.
  - f. Note the important information that is displayed in the factory dialog box.
  - g. Push the **OK Do Factory Calibration** side-bezel button to start the adjustment process.
  - h. You can cancel the process at any time by pushing the **MENU OFF** button.
6. Set the calibrator output signal as follows:

---

**NOTE.** *Incorrect use of calibration equipment can allow the oscilloscope to successfully complete the Calibration Procedure, and yet fail the Performance Verification.*

---

- a. View the prompt on the oscilloscope screen to determine the required signal type, amplitude, and frequency, as well as the required channel(s).
- b. Use the information provided on the following pages to set the calibrator for the required output signal:
  - DC Voltage –
  - Time Mark – (See page 14.)
  - Deskew – (See page 16.)
  - Sine – (See page 15.)
- c. On the oscilloscope, push the **OK Do Next Step** right-bezel button. The oscilloscope makes the adjustment, using the calibrator signal as a reference. You do not need to make any adjustments.

---

**NOTE.** *During the adjustment procedure, the oscilloscope makes the required settings to oscilloscope parameters, but does not display them on the screen.*

---

7. Continue with the adjustment process as follows:

---

**NOTE.** During some steps, the instrument may appear to be idle for several minutes while it is processing information internally.

---

- a. If you make an error, such as connecting the wrong input signal, push the **Return to Previous Screen** side bezel button and repeat the previous step. Push the button multiple times if you need to go back multiple steps.
  - b. If the oscilloscope fails a step, refer to *Troubleshooting* at the end of this section to fix the problem, and then repeat the previous step.
  - c. If a step fails twice, return to the first step in the adjustment procedure and try the entire procedure again. If the procedure still fails, it could indicate a problem with the oscilloscope. Contact Tektronix for technical support (see the contact information at the beginning of this manual).
8. When the adjustment procedure is complete, the factory dialog box appears, showing the updated time and date of the last successful adjustment. This completes the adjustments.
  9. Use the *Performance Verification procedure* to verify that the adjustment procedure correctly adjusted the oscilloscope to operate within specifications.

(See the *MSO4000B and DPO4000B Series Oscilloscopes Specifications and Performance Verification Technical Reference manual*, which is available at [www.tektronix.com/manuals](http://www.tektronix.com/manuals).)



## Setting the Calibrator Output Signal

This section tells how to set the calibrator for the DC Voltage, Time Mark, Deskew and Sine signals that are required by the adjustment procedure.

**DC Voltages** Use one of the following three methods to set the DC voltage: to 0 V, to any voltage into 1 M $\Omega$  or  $\leq 5.5$  V into 50  $\Omega$ , or to voltages over 5.5 V into 50  $\Omega$ .



### For 0 V.

Complete these steps to set the calibrator output for 0 V and start the adjustment step:

1. Push the **DC/Square**  button.
2. Ground the signal by pushing the grounding  lower-bezel button.
3. On the oscilloscope, push the **OK Do Next Step** right-bezel button.



### For voltages Into 1 M $\Omega$ and voltages $\leq 5.5$ V into 50 $\Omega$ .

Complete these steps to set the calibrator output for all DC voltages into 1 M $\Omega$  and voltages  $\leq 5.5$  V into 50  $\Omega$ .

1. *Select the calibrator signal type as follows:*
  - a. Push the **DC/Square**  button.
  - b. Push the **WAVEFORM** lower-bezel button, and then push the **DC Positive**  right-bezel button.
2. *Set the calibrator output channels and impedance as follows:*
  - a. Push the **CHANNEL SELECT** lower-bezel button.
  - b. Select the channel(s) specified by the oscilloscope prompt.
  - c. Push the **LOAD** lower-bezel button to highlight either **1 M $\Omega$**  or **50  $\Omega$** , as specified by the oscilloscope prompt.
  - d. Push the **EXIT** lower bezel button.
3. *Set the calibrator amplitude and start the adjustment step as follows:*
  - a. Select the **Amplitude** field using the front-panel tab key .
  - b. Set the voltage specified by the oscilloscope prompt.
  - c. Push the **ON** button and verify that the red light turns on to indicate that the calibrator output is on.
  - d. On the oscilloscope, push the **OK Do Next Step** right-bezel button.

**For voltages >5.5 V into 50  $\Omega$ .**

Complete these steps to set the calibrator output for a DC Voltage signal >5.5 V into 50  $\Omega$  (for example, to select **6 V** or **-6 V** in 50  $\Omega$  mode):

1. Push the AUX front panel button.
2. Push the  side-bezel button for positive polarity, or push the  side-bezel button for negative polarity.
3. Set the amplitude.
4. Set the Pulse Energy setting to 7.2 Joules (the Duration should show 10s).
5. When all of the parameters are set, push the ON button and verify that the calibrator output is on. Then push the **Trig Pulse** side-bezel button on the calibrator, to trigger a single shot of the specified pulse output. As soon as the calibrator settles (about one second), IMMEDIATELY push the **OK Do Next Step** side-bezel button on the oscilloscope.

---



**NOTE.** *The calibrator signal will remain at this voltage for only a few seconds, so the adjustment step must be done immediately after setting the calibrator amplitude.*

---

7. If the instrument fails one of these steps, go back and start from the first 6 V (6 V on channel 1) again.

**Time Mark**

Complete these steps to set the calibrator output for a Time Mark signal.



1. *Select the calibrator output signal type as follows:*
  - a. Push the **Markers**  front-panel button.
  - b. Push the **WAVEFORM** lower-bezel button.
  - c. Push the  side-bezel button.

---

**NOTE.** *If a 625 Hz signal is required, set the time marker to 1.6 ms.*





---

2. *Set the calibrator output channels and impedance as follows:*
  - a. Push the **CHANNEL SELECT** lower-bezel button.
  - b. Select the channel(s) specified by the oscilloscope prompt.
  - c. Push the **LOAD** lower-bezel button to highlight either **1 M $\Omega$**  or **50  $\Omega$** , as specified by the oscilloscope prompt.
  - d. Push the **EXIT** lower bezel button.

3. Verify that the calibrator is in direct mode by pushing the  lower-bezel button until 1.0 is selected.
4. *Set the calibrator amplitude as follows:*
  - a. Select the **Amplitude** field using the front-panel tab key .
  - b. Set the voltage specified by the oscilloscope prompt.
5. Push the **ON** button and verify that the red light turns on to indicate that the calibrator output is on.
6. On the oscilloscope, push the **OK Do Next Step** right-bezel button.

### Sine Signal

Complete these steps to set the calibrator output for a sine wave signal.

1. Push the **Sine**  front-panel button.
2. Verify that the calibrator is in direct mode by pushing the  lower-bezel button until 1.0 is selected.
3. *Set the calibrator amplitude as follows:*
  - a. Select the **Amplitude** field using the front-panel tab key .
  - b. Set the voltage specified by the oscilloscope prompt.
4. *Set the calibrator frequency as follows:*
  - a. Select the **Frequency** field using the front-panel tab key .
  - b. Set the frequency specified by the oscilloscope prompt.
5. *Set the calibrator output channels and impedance as follows:*
  - a. Push the **CHANNEL SELECT** lower-bezel button.
  - b. Select the channel(s) specified by the oscilloscope prompt.
  - c. Push the **LOAD** lower-bezel button to highlight either **1 M $\Omega$**  or **50  $\Omega$** , as specified by the oscilloscope prompt.
  - d. Push the **EXIT** lower bezel button.
6. Push the **ON** button and verify that the red light turns on to indicate that the calibrator output is on.
7. On the oscilloscope, push the **OK Do Next Step** right-bezel button.

**Deskew** Complete these steps to set the calibrator output for deskew.

---

**NOTE.** *If you are adjusting an MSO4000B Series, and the oscilloscope prompts you to connect the digital channels, connect the digital probe according to the instructions in Connecting the Equipment. (See page 9, Connecting the Equipment.)*



---

1. Set the calibrator output signal type as follows:
  - a. Push the **Aux** front-panel button.
  - b. Push the **Zero skew**  side-bezel button.

---

**NOTE.** *Selecting the deskew signal automatically turns all channels on.*

---

2. Set the calibrator termination and output channels as follows:
  - a. Push the **CHANNEL SELECT** lower-bezel button.
  - b. Select the channel(s) specified by the oscilloscope prompt.
  - c. Push the **LOAD** lower-bezel button to highlight either **1 M $\Omega$**  or **50  $\Omega$** , as specified by the oscilloscope prompt.
  - d. Push the **EXIT** lower bezel button.
3. Set the calibrator amplitude as follows:
  - a. Select the **Amplitude** field using the front-panel tab key .
  - b. Set the voltage specified by the oscilloscope prompt.
4. Set the calibrator frequency as follows:
  - a. Select the **Frequency** field using the front-panel tab key .
  - b. Set the frequency specified by the oscilloscope prompt.
5. Push the **ON** button and verify that the red light turns on to indicate that the calibrator output is on.
6. On the oscilloscope, push the **OK Do Next Step** right-bezel button. In some cases, the deskew can take several minutes.



---

**CAUTION.** *Keep the digital probe plugged in to the oscilloscope. Unplugging the probe can abort the adjustment.*

---

## Troubleshooting the Adjustment Procedure

Refer to the following table for solutions to problems that you might encounter during the calibration procedure.

Problem	Possible solutions
The instrument fails an adjustment step	<p>Are the channels hooked up properly?</p> <p>Is the signal being sent to the correct channels? (Check for the green lights on the probe heads.)</p> <p>Is the signal set to the correct waveform, frequency, and termination (if applicable to the adjustment step) ?</p> <p>Is the calibrator output set to <b>ON</b> ? (Is the red light illuminated?)</p> <p>If you make a correction or find that everything is correct, push the <b>Return to Previous Screen</b> side-bezel button on the oscilloscope to try the adjustment step again.</p>
I can't set the amplitude to 0 V, as specified in the prompt	<p>Ground the signal by pushing the lower-bezel button.</p> 
I can't find the parameters that I need to set	<p>Is the waveform set correctly?</p> <p>Is the grounding button on? When this is active, you will not be able to make a channel selection, so in some cases you might need to temporarily deselect the grounding option while you make a channel selection.</p> <p>If you cannot find the termination settings, click the <b>CHANNEL SELECT</b> lower-bezel button.</p>
I can't set the voltage to 625 Hz	<p>Set the time marker to 1.6 ms. This will automatically set the voltage to 625 Hz.</p>
I can't set the signal to all channels	<p>Select Multi-channel, and then turn on each channel, one by one.</p>
I'm having trouble with adjustment steps that require 6 V or -6 V	<p>Follow the instructions for <b>voltages &gt;5.5 V</b> that appear in the DC Voltage setups.</p> <p>Check the icon in the upper-left corner of the calibrator screen to be sure that the polarity is correct.</p> <p>If the instrument fails an adjustment step, go back to the first 6 V step (6 V on Channel 1) and start the sequence again.</p>
An adjustment step using the sine signal failed	<p>If the oscilloscope prompt specifies Channel 4, try setting the signal to Channel 5 instead.</p>



---

# Maintenance

This section contains the information needed to do periodic and corrective maintenance on the oscilloscope, as well as repackaging instructions for returning the oscilloscope to Tektronix for service.

## Preventing ESD

Before servicing this product, read the *General Safety Summary* and the *Service Safety Summary* at the front of the manual, and familiarize yourself with the following electrostatic discharge (ESD) information.



**CAUTION.** *Static discharge can damage any semiconductor component in this oscilloscope.*

---

When performing any service that requires internal access to the oscilloscope, adhere to the following precautions to avoid damaging internal modules and their components due to electrostatic discharge.

1. Minimize handling of static-sensitive circuit boards and components.
2. Transport and store static-sensitive modules in their static protected containers or on a metal rail. Label any package that contains static-sensitive boards.
3. Discharge the static voltage from your body by wearing a grounded antistatic wrist strap while handling these modules. Service static-sensitive modules only at a static-free work station.
4. Do not place anything capable of generating or holding a static charge on the work station surface.
5. Handle circuit boards by the edges when possible.
6. Do not slide the circuit boards over any surface.
7. Avoid handling circuit boards in areas that have a floor or work-surface covering capable of generating a static charge.

## Inspection and Cleaning

Inspection and cleaning are done as preventive maintenance. Preventive maintenance, when done regularly, may prevent oscilloscope malfunction and enhance its reliability.

Preventive maintenance consists of visually inspecting and cleaning the oscilloscope and using general care when operating it.

How often you do maintenance depends on the severity of the environment in which the oscilloscope is used. A proper time to perform preventive maintenance is just before oscilloscope adjustment.

**General Care** The cabinet helps keep dust out of the oscilloscope and should normally be in place when operating the oscilloscope.



**WARNING.** *To avoid injury, power off the instrument and disconnect it from line voltage before performing any procedure that follows.*

---

**Flat Panel Display Cleaning** The display is a soft plastic display and must be treated with care during cleaning.



**CAUTION.** *Improper cleaning agents or methods can damage the flat panel display.*

*Avoid using abrasive cleaners or commercial glass cleaners to clean the display surface.*

*Avoid spraying liquids directly on the display surface.*

*Avoid scrubbing the display with excessive force.*

---

Clean the flat panel display surface by gently rubbing the display with a clean-room wipe (such as Wypall Medium Duty Wipes, #05701, available from Kimberly-Clark Corporation).

If the display is very dirty, moisten the wipe with distilled water or a 75% isopropyl alcohol solution and gently rub the display surface. Avoid using excess force or you may damage the plastic display surface.

### Exterior Cleaning



**CAUTION.** *To prevent getting moisture inside the oscilloscope during external cleaning, use only enough liquid to dampen the cloth or applicator.*

---

Clean the exterior surfaces of the chassis with a dry lint-free cloth or a soft-bristle brush. If any dirt remains, use a cloth or swab dipped in a 75% isopropyl alcohol solution. Use a swab to clean narrow spaces around controls and connectors. Do not use abrasive compounds on any part of the chassis that might damage the chassis.

Clean the power switch using a dampened cleaning towel. Do not spray or wet the switch directly.



**CAUTION.** Avoid the use of chemical cleaning agents, which might damage the plastics used in this oscilloscope. Use only deionized water when cleaning the menu buttons or front-panel buttons. Use a 75% isopropyl alcohol solution as a cleaner and rinse with deionized water. Before using any other type of cleaner, consult your Tektronix Service Center or representative.

### Exterior Inspection

Inspect the outside of the oscilloscope for damage, wear, and missing parts, using the following table as a guide. Immediately repair defects that could cause personal injury or lead to further damage to the oscilloscope.

**Table 1: External inspection checklist**

Item	Inspect for	Repair action
Cabinet, front panel, and cover	Cracks, scratches, deformations, damaged hardware.	Repair or replace defective module.
Front-panel knobs	Missing, damaged, or loose knobs.	Repair or replace missing or defective knobs.
Connectors	Broken shells, cracked insulation, and deformed contacts. Dirt in connectors.	Repair or replace defective modules. Clear or wash out dirt.
Carrying handle, and cabinet feet	Correct operation.	Repair or replace defective module.
Accessories	Missing items or parts of items, bent pins, broken or frayed cables, and damaged connectors.	Repair or replace damaged or missing items, frayed cables, and defective modules.

### Interior Inspection

To access the inside of the oscilloscope for cleaning and inspection, refer to the exploded view diagrams. (See page 31, *Replaceable Parts List*.)

Inspect the internal portions of the oscilloscope for damage and wear, using the following table as a guide. Repair any defects immediately.

If any circuit board is repaired or replaced, you must perform the Adjustments Procedure. (See page 7, *Adjustment Procedure*.)



**CAUTION.** To prevent damage from electrical arcing, make sure that circuit boards and components are dry before applying power to the oscilloscope.

**Table 2: Internal inspection checklist**

Item	Inspect for	Repair action
Circuit boards	Loose, broken, or corroded solder connections. Burned circuit boards. Burned, broken, or cracked circuit-run plating.	Remove and replace damaged circuit board.

**Table 2: Internal inspection checklist (cont.)**

Item	Inspect for	Repair action
Resistors	Burned, cracked, broken, blistered condition.	Remove and replace damaged circuit board.
Solder connections	Cold solder or rosin joints.	Resolder joint and clean with isopropyl alcohol.
Capacitors	Damaged or leaking cases. Corroded solder on leads or terminals.	Remove and replace damaged circuit board.
Wiring and cables	Loose plugs or connectors. Burned, broken, or frayed wiring.	Firmly seat connectors. Repair or replace modules with defective wires or cables.
Chassis	Dents, deformations, and damaged hardware.	Straighten, repair, or replace defective hardware.

**Interior Cleaning**

1. Blow off dust with dry, low-pressure, deionized air (approximately 9 psi).
2. Remove any remaining dust with a lint-free cloth dampened in isopropyl alcohol (75% solution) and rinsed with warm deionized water. (A cotton-tipped applicator is useful for cleaning in narrow spaces and on circuit boards.)

---

**NOTE.** *If, after performing steps 1 and 2, a module is clean upon inspection, skip the following steps.*

*If there is still dust or dirt on the module, the oscilloscope may be spray washed using a solution of 75% isopropyl alcohol by following these steps:*

---

- a. Spray wash dirty parts with isopropyl alcohol and wait 60 seconds for the majority of the alcohol to evaporate.
- b. Use hot (120 °F to 140 °F) deionized water to thoroughly rinse them.
- c. Dry all parts with low-pressure, deionized air.
- d. Dry all components and assemblies in an oven or drying compartment using low-temperature (125 °F to 150 °F) circulating air.

**Lubrication**

There is no periodic lubrication required for this oscilloscope.

## Module Removal



---

**WARNING.** Only qualified personnel should perform service procedures. Before performing this or any other procedure in this manual, read the *General Safety Summary and Service Safety Summary* located at the beginning of this manual. Also, to prevent possible injury to service personnel or damage to electrical components, read *Preventing ESD*. (See page 19, *Preventing ESD*.)

---

To work on the instrument, place it face down in its protective front cover. You can remove the tabs from the cover if you want to make it easy to move the instrument in and out of the cover while working on it.



**Figure 2: Removing tabs from the front protective cover**

To remove as assembly, refer to the module locator illustration. (See Figure 3 on page 24.)

You can also refer to the exploded view diagrams and parts lists. (See page 31, *Replaceable Parts List*.) The parts lists show how many of each type of screw is used to attach each replaceable module.

If you are disassembling the instrument for cleaning, refer to the *Inspection and Cleaning* procedure for instructions. (See page 19, *Inspection and Cleaning*.)



---

**WARNING.** Before doing any procedure in this subsection, disconnect the power cord from the line voltage source. Failure to do so could cause serious injury or death.

---

### Required Equipment

You will need a Torx-driver with a T-15 Torx tip to remove instrument screws.

**To Remove Modules**

- To remove any of the instrument modules or assemblies, you must first remove the rear cover and separate the front chassis from the rear chassis.
- To remove the Front Panel board assembly or the front panel case assembly, you must first remove the Main board assembly, the Analog board assembly, and the front chassis.
- To remove or install the keypad, do not touch the switch contacts with your fingers. The oils on your fingers will degrade or damage the switch contacts. To help prevent damage to the keypad, use cotton gloves when removing or installing the keyboard pad.

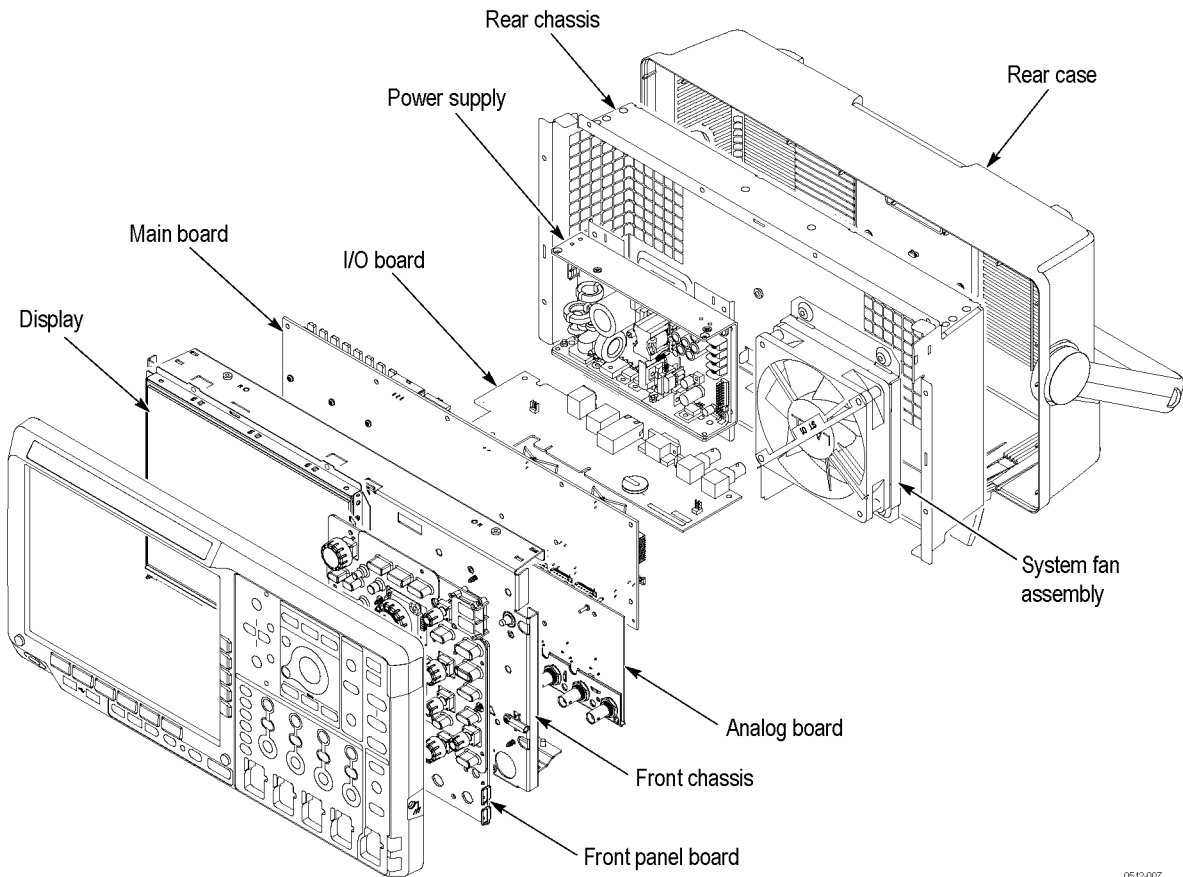

0512-007

**Figure 3: Module locator**

## Troubleshooting

This section contains information and procedures to help you isolate a defective module in the MSO4000B Series and DPO4000B Series oscilloscopes.



**WARNING.** Before performing this or any other procedure in this manual, read the General Safety Summary and Service Safety Summary found at the beginning of this manual, and, to prevent possible injury to service personnel or damage to electrical components, read Preventing ESD. (See page 19, Preventing ESD.)

### Adjustment After Repair

If you replace any circuit board assembly, you must adjust the instrument after repair. Refer to the *Adjustment Procedures* section for information about the adjustment. (See page 7, *Adjustment Procedure*.)

### Required Tools and Equipment

You need the following equipment to troubleshoot the instrument.

Tools and Equipment	Example
DMM	3.5 digits or above

### Test Points

Test points on the Main board are shown in the troubleshooting illustration. (See Figure 5.)

## Troubleshooting Procedure

The following figures are troubleshooting procedure flowcharts. Use them to troubleshoot an instrument failure. Begin with the Primary troubleshooting procedure flowchart. (See Figure 4.)



**WARNING.** Before removing the cabinet, disconnect the power cord from the line voltage source. Failure to do so could cause serious injury or death.

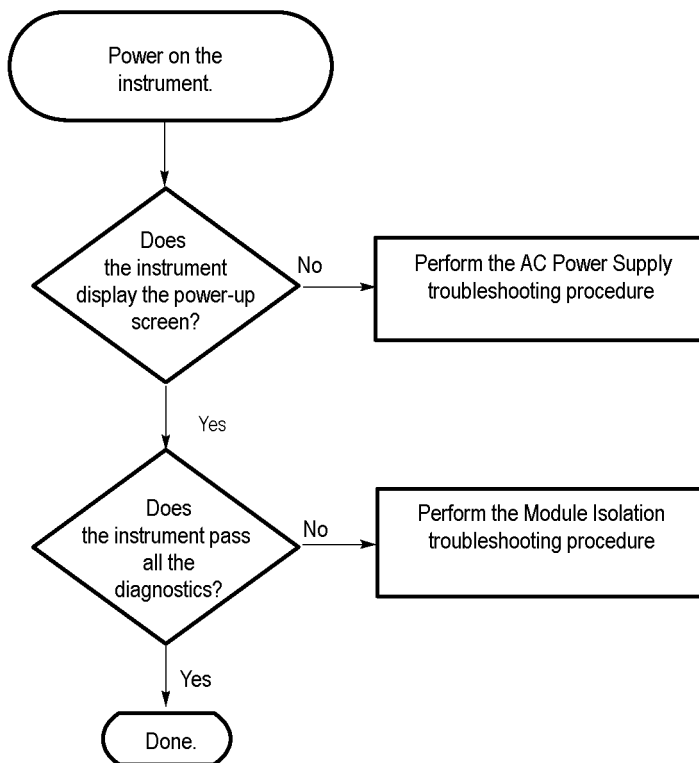

**Figure 4: Primary troubleshooting procedure**

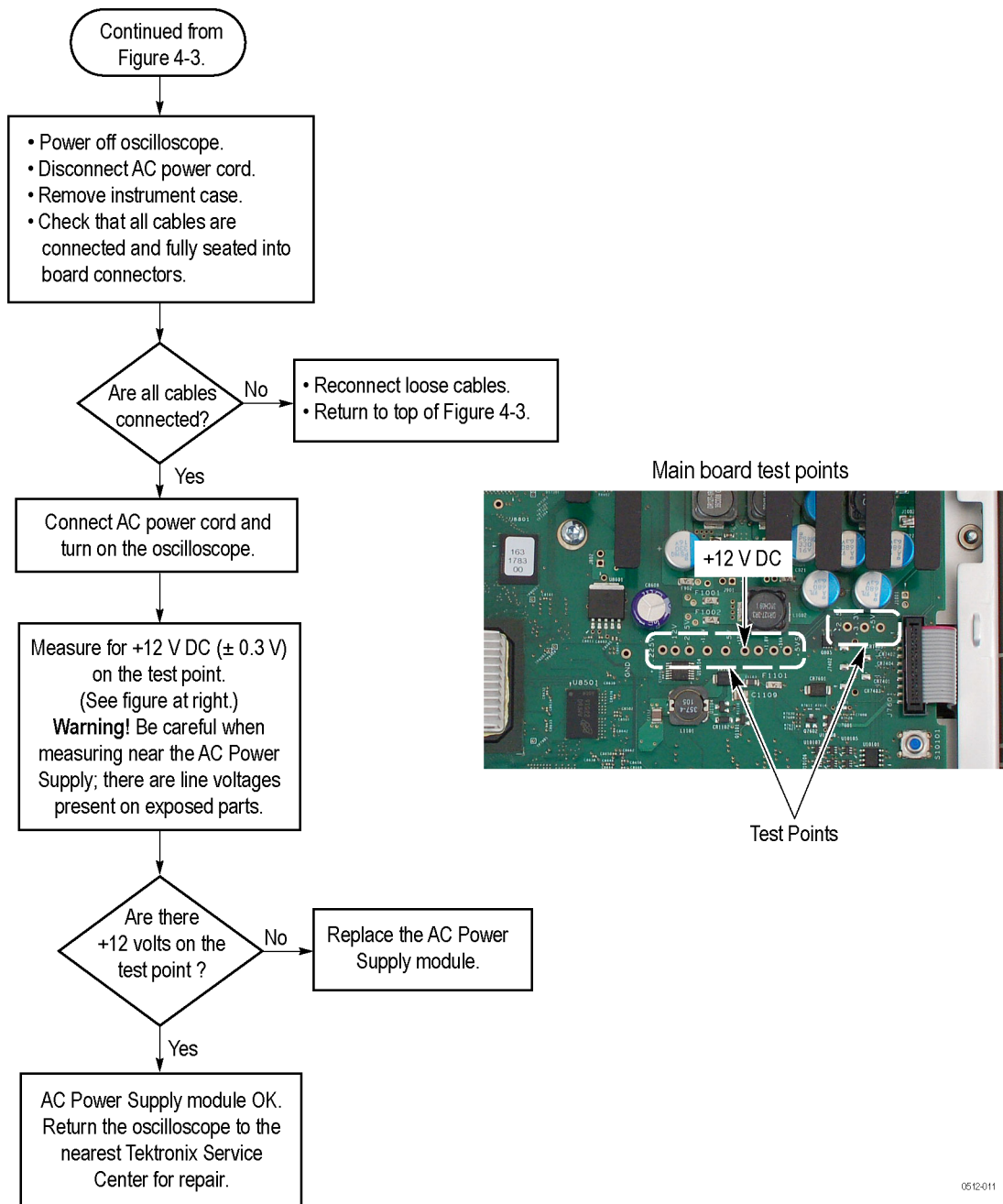
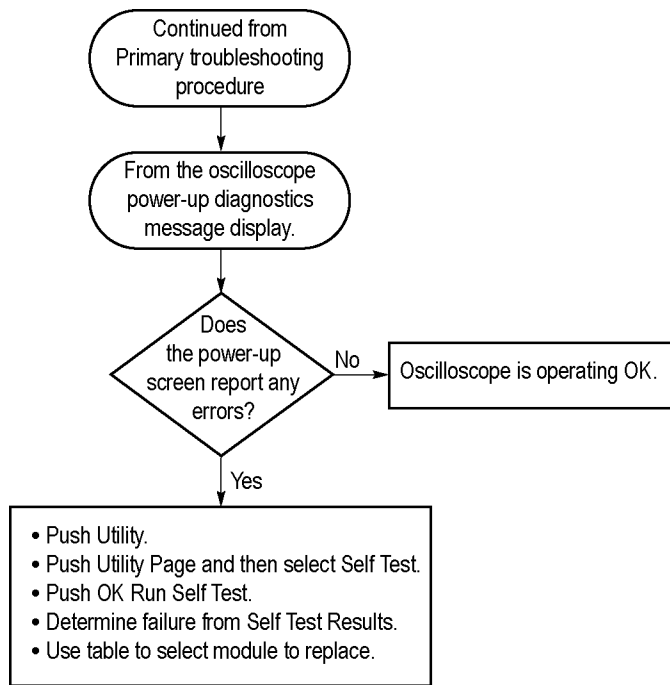

Figure 5: AC power supply troubleshooting procedure

**NOTE.** The test point voltages are printed on the Main board. From left to right in the illustration, they are: +1.225 V, -1.2 V, -2.5 V, +1.5 V, -5 V, +12 V, +1.8 V, +5 VA, +5 VSB, and +2.5 V, +3.3 V, +5 V.



Failed Test	Most Likely Cause
CPU	Main board
Display	Main board
Acquisition	Main board
ROM	Main board
App Modules	Front Panel or App Keys
Front Panel	Front Panel or Main board
I/O	Main board

05/20/12

**Figure 6: Module isolation troubleshooting procedure**

## Unpacking and Repacking Instructions

This section contains the information needed to unpack the oscilloscope and repack it for shipment or storage.

**Unpacking** The oscilloscope and its standard accessories are carefully packed at the factory in a shipping carton. If, upon receipt, damage to the shipping carton is evident, tell the shipper. Tektronix, Inc. is not responsible for damage caused during shipping.

If you have not already done so, carefully remove the oscilloscope and its accessories from the shipping carton and inspect them for damage. Save the shipping carton for repacking or storage.

**Repacking** Use a corrugated cardboard shipping carton having a test strength of at least 275 pounds (125 kg) and with an inside dimension at least six inches (15.25 cm) greater than the instrument dimensions.

If the instrument is being shipped to a Tektronix Service Center, enclose the following information:

- The owner's address
- Name and phone number of a contact person
- Type and serial number of the instrument
- Reason for returning
- A complete description of the service required

Seal the shipping carton with an industrial stapler or strapping tape.

Mark the address of the Tektronix Service Center and also your own return address on the shipping carton in two prominent locations. See [www.tektronix.com/service](http://www.tektronix.com/service) to find a service center near you.

**Storage** The oscilloscope should be stored in a clean, dry environment. The following environmental characteristics apply for both shipping and storage:

- Temperature range:  $-4^{\circ}\text{F}$  to  $+140^{\circ}\text{F}$  ( $-20^{\circ}\text{C}$  to  $+60^{\circ}\text{C}$ )
- Altitude: To 30,000 feet (9144 m )

See the Tektronix *MSO4000B and DPO4000B Series Digital Phosphor Oscilloscopes Specifications and Performance Verification Technical Reference* for a complete listing of the environmental specifications.



# Replaceable Parts List

This chapter contains a list of the replaceable modules for the DPO4000B and MSO4000B Series Oscilloscopes. Use this list to identify and order replacement parts.

## Parts Ordering Information

Replacement parts are available through your local Tektronix field office or representative.

Changes to Tektronix products are sometimes made to accommodate improved components as they become available and to give you the benefit of the latest improvements. Therefore, when ordering parts, it is important to include the following information in your order.

- Part number (see *Part Number Revision Level* below)
- Instrument type or model number
- Instrument serial number
- Instrument modification number, if applicable

If you order a part that has been replaced with a different or improved part, your local Tektronix field office or representative will contact you concerning any change in part number.

Change information, if any, is located at the rear of this manual.

### Part Number Revision Level

Tektronix part numbers contain two digits that show the revision level of the part. For some parts in this manual, you will find the letters XX in place of the revision level number.

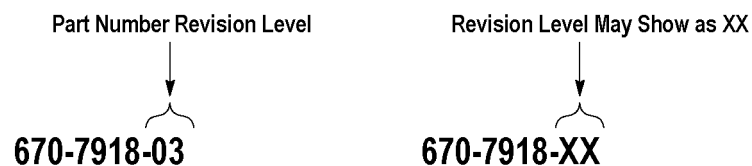

When you order parts, Tektronix will provide you with the most current part for your product type, serial number, and modification (if applicable). At the time of your order, Tektronix will determine the part number revision level needed for your product, based on the information you provide.

### Module Servicing

Modules can be serviced by selecting one of the next three options. Contact your local Tektronix service center or representative for repair assistance.

**Module exchange.** In some cases you may exchange your module for a remanufactured module. These modules cost significantly less than new modules and meet the same factory specifications. For more information about the module exchange program, call 1-800-833-9200, extension 2.

**Module repair and return.** You may ship your module to us for repair, after which we will return it to you.

**New modules.** You may purchase replacement modules in the same way as other replacement parts.

## Using the Replaceable Parts List

This section contains a list of the mechanical and/or electrical components that are replaceable for the instrument. Use this list to identify and order replacement parts. The following table describes each column in the parts list.

**Table 3: Parts list column descriptions**

Column	Column Name	Description
1	Figure & Index Number	Items in this section are referenced by figure and index numbers to the exploded view illustrations that precede the list.
2	Tektronix Part Number	Use this part number when ordering replacement parts from Tektronix.
3 and 4	Serial Number	Column three indicates the serial number at which the part was first effective. Column four indicates the serial number at which the part was discontinued. No entries indicates the part is good for all serial numbers.
5	Qty	This indicates the quantity of parts used.
6	Name & Description	An item name is separated from the description by a colon (:). Because of space limitations, an item name may sometimes appear as incomplete. Use the U.S. Federal Catalog handbook H6-1 for further item name identification.

**Abbreviations**      Abbreviations conform to American National Standard ANSI Y1.1-1972.

**Exploded Views**      Figures 5-1 through 5-8 on the following pages show the module-level exploded views of the DPO4000B Series and the MSO4000B Series oscilloscopes. Each exploded view is indexed by the numbers in the figure.

Table 4: Replaceable parts – Front Panel assembly

Fig. & index number	Tektronix part number	Serial no. effective	Serial no. discount'd	Qty	Name & description
7-					<b>FRONT PANEL ASSEMBLY</b>
-1	065-0854-00			1	FRONT CASE ASSEMBLY, MSO4000B SERIES
	065-0855-00			1	FRONT CASE ASSEMBLY, DPO4000B SERIES
-2	366-0861-01			2	ASSEMBLY, KNOB: .925 DIAMETER, SOFT TOUCH
-3	366-0865-00			1	KNOB ASSEMBLY, SHUTTLE AND BUSHING
-4	366-0867-01			1	KNOB ASSEMBLY, JOG
-5	366-0859-01			6	ASSEMBLY, KNOB: .470 DIAMETER, SOFT TOUCH
-6	366-0860-01			6	ASSEMBLY, KNOB: .685 DIAMETER, SOFT TOUCH
-7	335-2366-00			1	LABEL. FRONT PANEL, OVERLAY, FRENCH
	335-2367-00			1	LABEL. FRONT PANEL, OVERLAY, ITALIAN
	335-2368-00			1	LABEL. FRONT PANEL, OVERLAY, GERMAN
	335-2369-00			1	LABEL. FRONT PANEL, OVERLAY, SPANISH
	335-2370-00			1	LABEL. FRONT PANEL, OVERLAY, JAPANESE
	335-2371-00			1	LABEL. FRONT PANEL, OVERLAY, PORTUGUESE
	335-2372-00			1	LABEL. FRONT PANEL, OVERLAY, SIMPLIFIED CHINESE
	335-2373-00			1	LABEL. FRONT PANEL, OVERLAY, TRADITIONAL CHINESE
	335-2374-00			1	LABEL. FRONT PANEL, OVERLAY, KOREAN
	335-2375-00			1	LABEL FRONT PANEL OVERLAY, RUSSIAN
-8	260-2898-00			1	SWITCH, KEYPAD, ELASTOMERIC, POWER
-9	407-5259-00			1	BRACKET, SUPPORT: POWER SWITCH
-10	211-1273-00			19	SCREW, MACHINE: 6–32 x 0.250, PNH, STL, ZNPL, T-15 TORX DRIVE ----- DISTRIBUTION OF THE 211-1273-00 SCREWS ----- 2 screws attach the Power switch and bracket to the front case assembly. 2 screws attach the Utility switch and bracket to the front case assembly. 10 screws attach the Front panel assembly to the front case assembly – with contact springs (#15). 5 screws across the bottom of the Front panel assembly attach it to the front case assembly – without contact springs.
-11	260-2858-00			1	SWITCH, KEYPAD, ELASTOMERIC, UTILITY
-12	407-2567-00			1	BRACKET, SUPPORT, UTILITY SWITCH
-13	260-2900-00			1	SWITCH, KEYPAD, ELASTOMERIC, FRONT PANEL
-14	870-0277-01			1	CIRCUIT BOARD ASSEMBLY, FRONT PANEL
-15	131-8139-00			10	CONTACT, SPRING: FRONT PANEL ELEC
-16	200-5049-00			1	COVER; OPTION KEY DOOR, 0.7270 X 1.2250 X 0.310, PC/ABS, FR110, SILVER GRAY

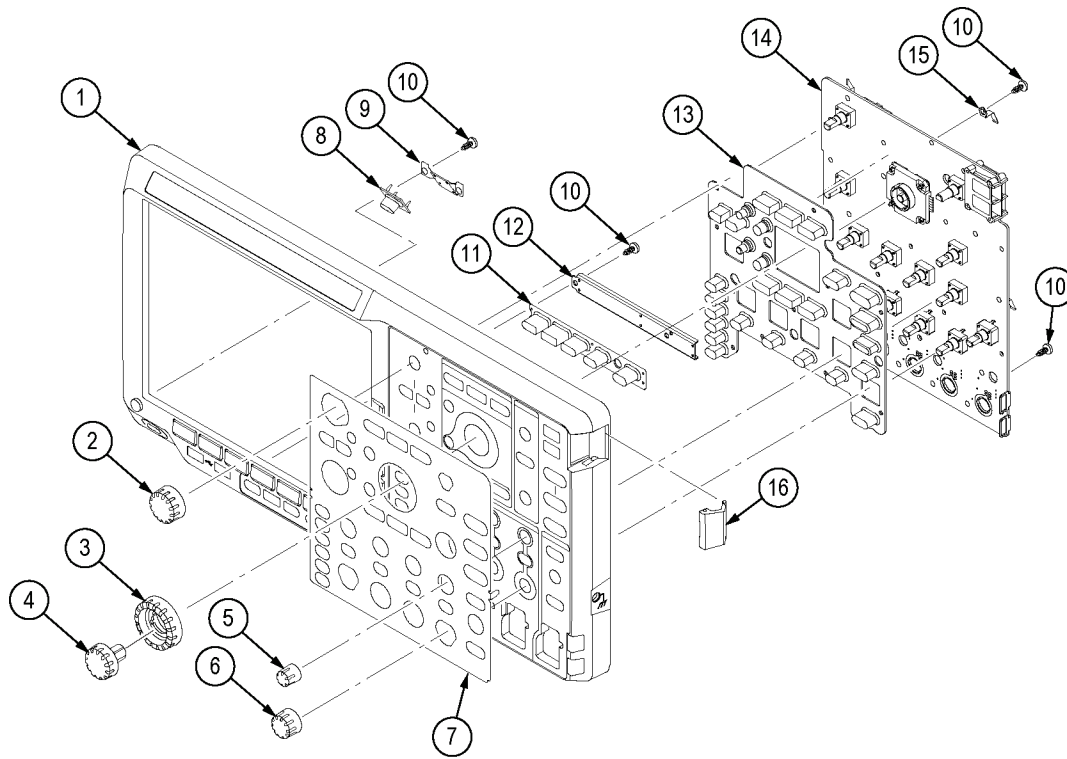

0512-001

**Figure 7: Exploded view, Front Panel assembly**

**Table 5: Replaceable parts – Display, Analog board, and Main board**

Figure and index no.	Tektronix part no.	Serial no. effective	Serial no. discontin'd	Qty.	Name and description
<b>8-</b>					<b>DISPLAY, ANALOG BOARD &amp; MAIN BOARD</b>
-1	850-0110-00			1	FRAME ASSEMBLY, DISPLAY: LCD
-2	211-1272-00			40	SCREW, MACHINE: 6–32 x 0.250, PNH, STL, ZNPL, T-15 TORX DRIVE ----- DISTRIBUTION OF THE 211-1272-00 SCREWS ----- 6 screws attach the LCD assembly to the front chassis. 15 screws attach the Main board assembly to the front chassis. 6 screws attach the Analog board assembly to the front chassis. 12 screws attach the rear chassis to the front chassis: 4 across the top flange of the rear chassis, 2 on each side flange, and 4 across the bottom flange of the front chassis. 1 screw attaches the ground jack to the front chassis.
-3	441-2608-00			1	CHASSIS ASSEMBLY, FRONT
-4	211-1273-00			8	SCREW, PT, K35–1.57, PAN HEAD, STL, ZNPL, T-15 TORX DRIVE
-5	131-6643-00			6	CONTACT, ELEC: GROUNDING, 0.169 L X 0.250 W X 0.320 D, ELECTROLESS NICKEL PLATE
-6	131-6417-00			4	CONTACT, ELEC: GROUNDING, 0.600 L X 0.250 W X 0.220 D, ELECTROLESS NICKEL PLATE
-7	131-7622-00			1	CONN, RECEPT; GROUND JACK
-8	-----			1	MAIN BOARD ASSEMBLY. Return the instrument to Tektronix for service. Must be replaced with the ANALOG BOARD ASSEMBLY.
-9	-----			1	ANALOG BOARD ASSEMBLY. Return the instrument to Tektronix for service. Must be replaced with the MAIN BOARD ASSEMBLY.
-10	351-1134-00			1	DIGITAL PROBE GUIDE (MSO models only)
-11	129-1693-00			1	SPACER, POST

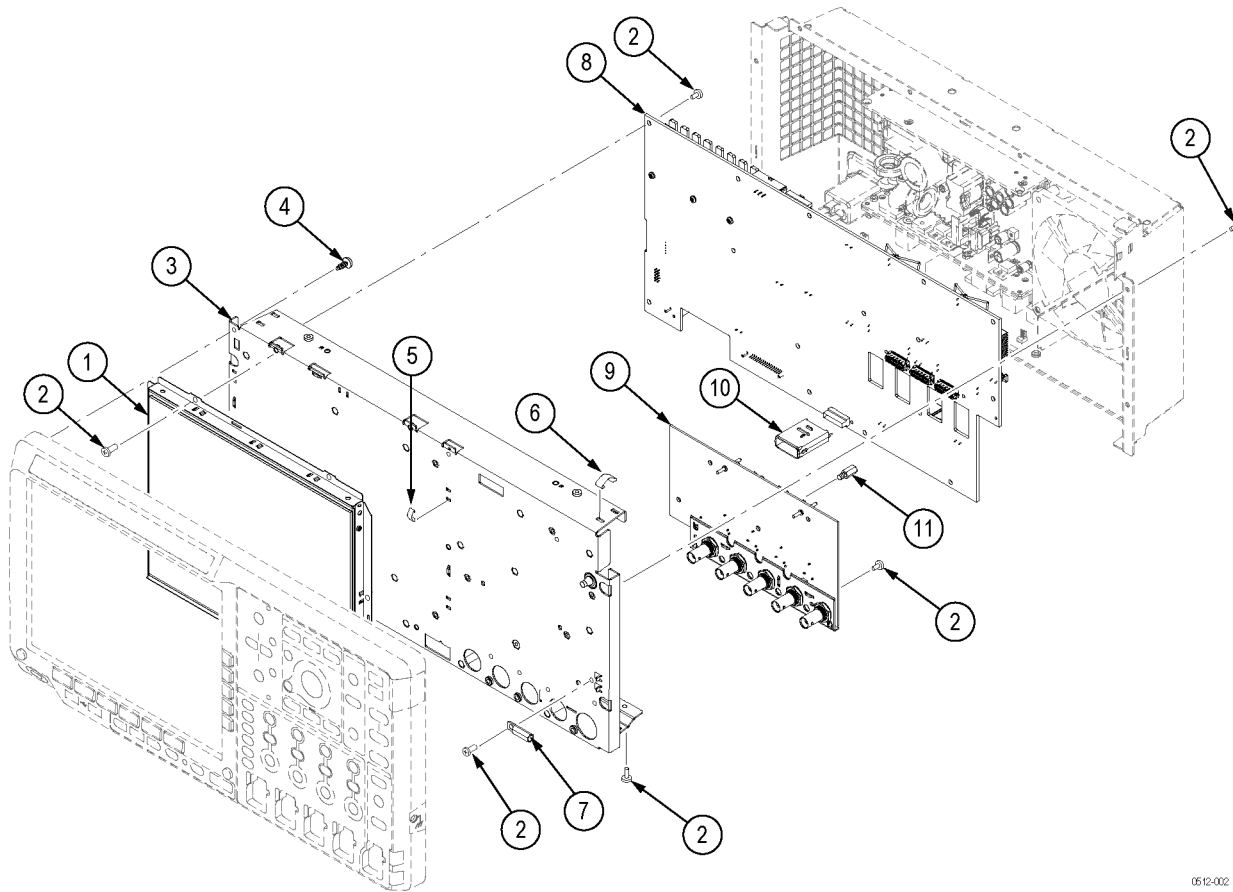

0512-002

**Figure 8: Display, Analog board, and Main board assembly**

**Table 6: Replaceable parts – Rear chassis and connecting modules**

Figure and index no.	Tektronix part no.	Serial no. effective	Serial no. discont'd	Qty.	Name and description
<b>9-</b>					<b>REAR CHASSIS, POWER SUPPLY, I/O BOARD</b>
-1	119-7597-00			1	POWER SUPPLY; ROHS COMPLIANT; SAFETY CONTROLLED
-2	211-1272-00			15	SCREW, MACHINE: 6–32 x 0.250, PNH, STL, ZNPL, T-15 TORX DRIVE ----- DISTRIBUTION OF THE 211-1272-00 SCREWS ----- 1 screw attaches the I/O board to the rear chassis. 4 screws attach the Power supply circuit board to the Power supply bracket. 4 screws attach the Power supply bracket to the rear chassis. 2 screws attach the line filter to the rear chassis. 4 screws attach the system fan (#12) to the rear chassis.
-3	407-5462-00			1	BRACKET, POWER SUPPLY BOARD MOUNT
-4	878-0278-01			1	I/O BOARD ASSEMBLY
-5	119-7086-00			1	FILTER, EMI, AC LINE CONNECTOR
-6	441-2609-00			1	CHASSIS ASSEMBLY, REAR
-7	131-6417-00			1	CONTACT, ELEC: GROUNDING, 0.600 L X 0.250 W X 0.220 D, ELECTROLESS NICKEL PLATE
-8	214-3903-00			2	SCREW, JACK; 4-40 X 0.312 LONG, 0.188 H HEX HEAD STAND OFF
-9	210-1039-00			2	WASHER, LOCK; 0.521 ID, INT, 0.025 THK, STEEL, ZINC FINISH
-10	220-0265-00			2	NUT, PLAIN, HEX; 0.5-28 X 0.625
-11	065-0861-00			1	SYSTEM FAN ASSEMBLY, 120 MM, TUBEAXIAL, 12 VDC; SAFETY CONTROLLED, WITH BRACKET
-12	335-1910-00			1	MARKER, IDENT: SERIAL NUMBER LABEL
-13	335-2248-00			1	LABEL, IO, REAR

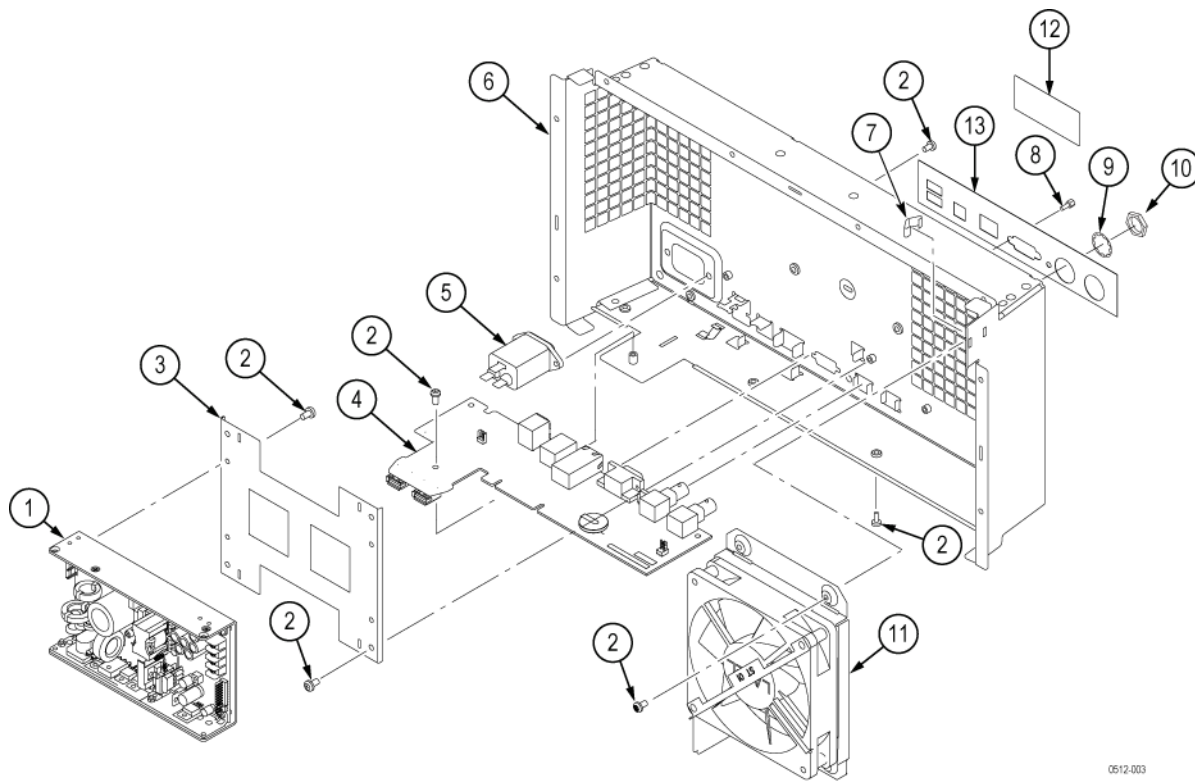

0512-003

Figure 9: Rear chassis and connecting modules

Table 7: Replaceable parts – external parts

Figure and index no.	Tektronix part no.	Serial no. effective	Serial no. discont'd	Qty.	Name and description
<b>10-</b>					<b>EXTERNAL PARTS</b>
-1	200-5130-00			1	FRONT PROTECTIVE COVER
-2	065-0856-00			1	REAR CASE ASSEMBLY
-3	211-1272-00			4	SCREW, MACHINE: 6-32 x 0.250, PNH, STL, ZNPL, T-15 TORX DRIVE

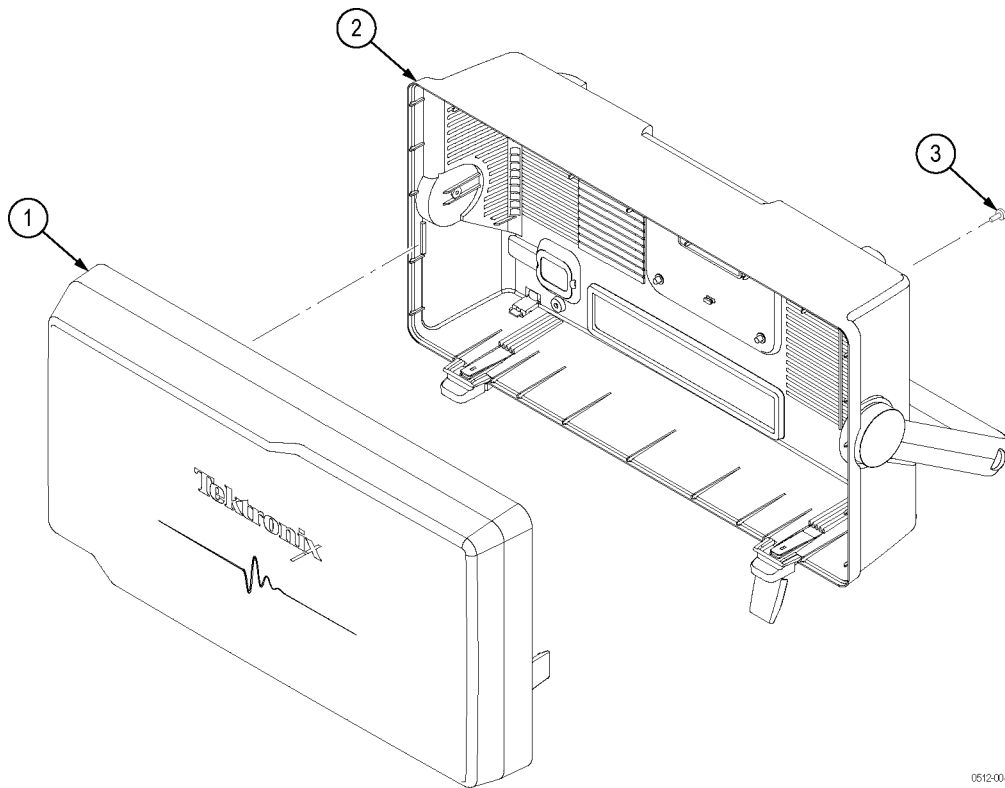

0512-004

Figure 10: External parts

**Table 8: Replaceable parts – cable and connectors, rear chassis**

Figure and index no.	Tektronix part no.	Serial no. effective	Serial no. discont'd	Qty.	Name and description
<b>11-</b>					<b>CABLES, REAR CHASSIS</b>
-1	174-5835-00			1	CABLE ASSEMBLY, LINE INPUT
-2	343-1736-00			2	CLAMP, CABLE

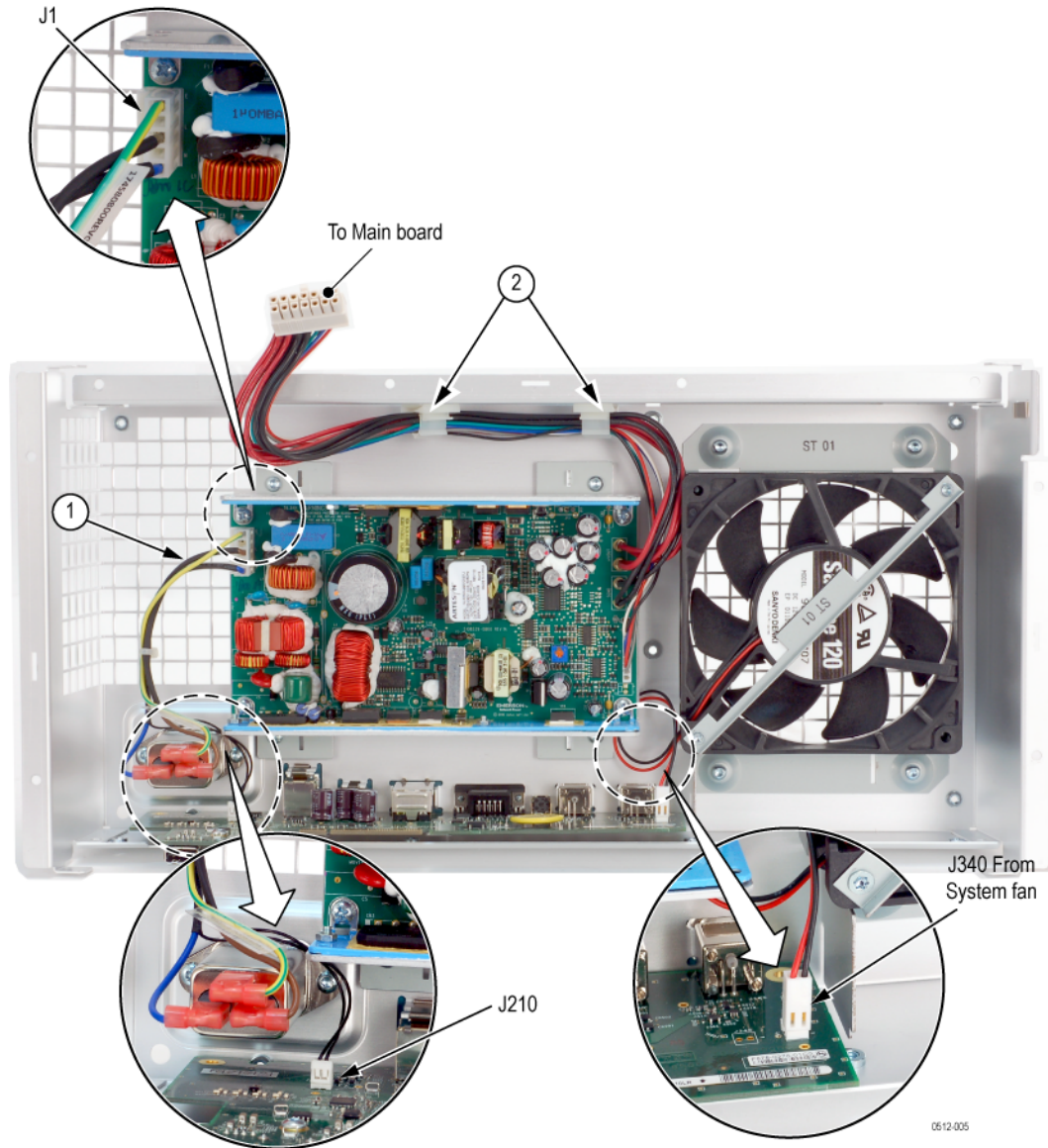

**Figure 11: Rear chassis, showing cables and connectors**

Table 9: Replaceable parts – cable and connectors, Main board

Figure and index no.	Tektronix part no.	Serial no. effective	Serial no. discont'd	Qty.	Name and description
12-					<b>Cable, Main Board</b>
-1	174-5809-00			1	CABLE, MAIN BOARD TO FRONT PANEL BOARD
-2	346-0120-00			1	STRAP, TIEDOWN; 5.5 L MIN, PLASTIC, WHITE

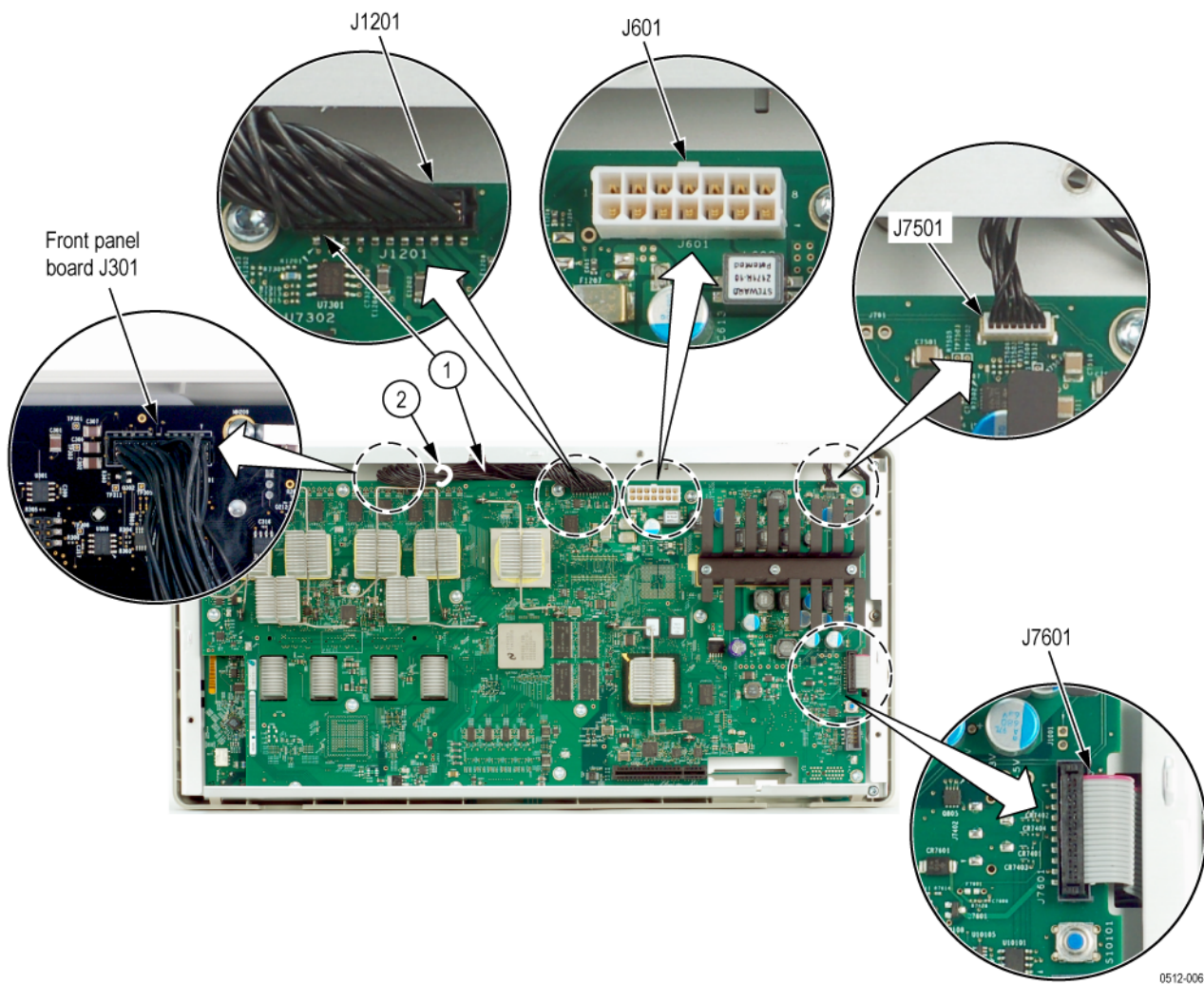

0512-006

Figure 12: Main board, showing cable and connectors