

Panasonic
ideas for life

**MINIATURE SWITCHES
WITH HIGH PRECISION**

**AM5 (QV)
SWITCHES**

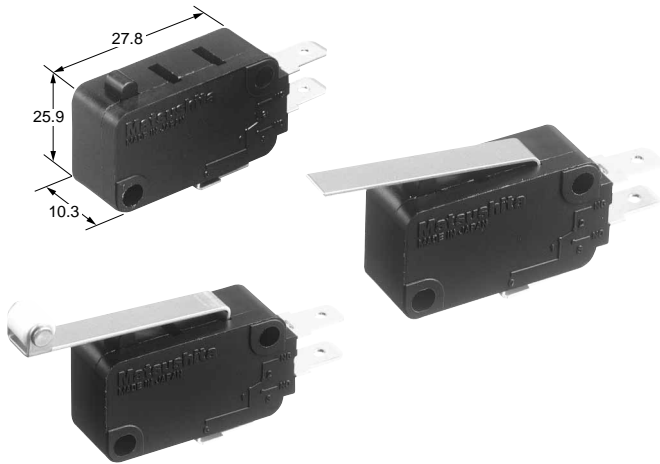

FEATURES

- High precision as a result of designing ideal spring by using computer analysis
O.P. 14.7 ± 0.4 mm
- Reliable design with shock resistance min. 980 m/s²
- High inrush resistance 160A
- Wide variety of contact ratings and terminal types
- UL/CSA/VDE/SEMKO approved

TYPICAL APPLICATION

- Home appliances
- Vending machines
- Amusement and communication equipment
- Copies
- General industrial machines

Standard type contact gap is 1mm. Please consult us if you need more than 1mm contact gap.

CONSTRUCTION

1. Silver alloy contact

2. Gold clad contact

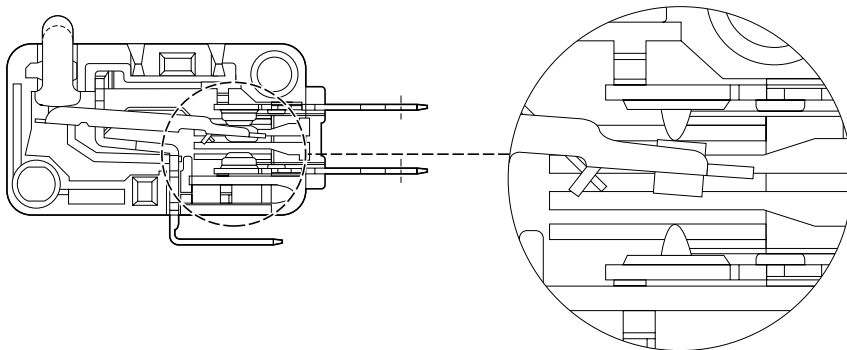

CONTACT ARRANGEMENT

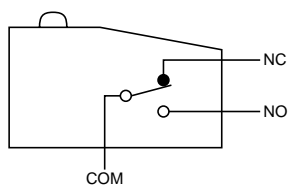

TERMINALS

.187 Quick-connect terminal
.187 Quick-connect/solder terminal
 Bottom COM terminal

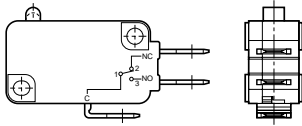

Side COM terminal

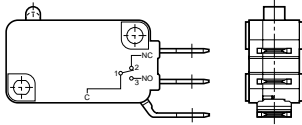

Dimensions
 .187 Quick-connect terminal

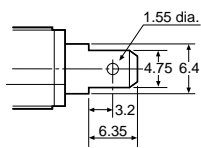

Dimensions
 .187 Quick-connect/solder terminal

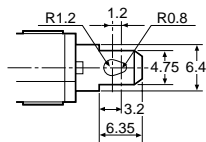

.250 Quick-connect terminal
 Bottom COM terminal

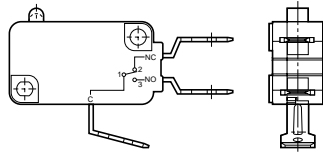

Side COM terminal

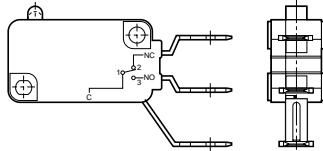

Dimensions

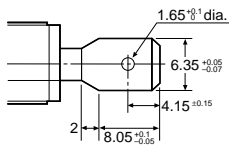

GUARDS

Guarded types are available only for Side COM terminal type (.187 Quick-connect). All types of bottom COM are not guarded.

Left hand guarded

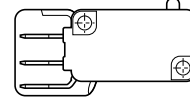

Right hand guarded

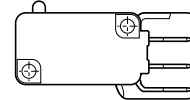

OPERATION FORCE CHART

7th digit of Part Number/Actuator	Operation Force, Max. by actuator				
	3	4	5	6	7
Pin plunger	0.49N	0.98N	1.96N	2.94N	3.92N
Short hinge lever	0.59N	1.08N	2.16N	3.14N	4.12N
Hinge lever	0.29N	0.59N	1.18N	1.77N	2.35N
Long hinge lever	0.15N	0.29N	0.59N	0.88N	1.18N
Simulated roller lever	0.29N	0.59N	1.18N	1.77N	2.35N
Short roller lever	0.59N	1.08N	2.16N	3.14N	4.12N
Roller lever	0.29N	0.59N	1.18N	1.77N	2.35N

AM5

ORDERING INFORMATION

0.1A type

Ex. AM5 0 0 1 0 C 5 R 3

Type of switch	Contact rating	Terminals	Actuators	Terminals	Operating force by pin plunger (max.)	Guard	Agency standard
AM5: QV switch	00: 0.1 A (Gold clad)	1: Bottom COM, SPDT 2: Bottom COM, SPST-NC 3: Bottom COM, SPST-NO 4: Side COM, SPDT 5: Side COM, SPST-NC 6: Side COM, SPST-NO	0: Pin plunger 1: Short hinge lever 2: Hinge lever 3: Long hinge lever 4: Simulated roller lever 5: Short roller lever 6: Roller lever	A: .187 Quick-connect/ solder terminal C: .187 Quick-connect terminal	3: 0.49 N 4: 0.98 N 5: 1.96 N	R: Right hand guarded L: Left hand guarded	3: UL/CSA 6 × 10 ³ rated, VDE and SEMKO approved

* Please refer to the Standard Chart regarding Agency Standard

6A type

Ex. AM5 0 6 1 0 C 5 R 3

Type of switch	Contact rating	Terminals	Actuators	Terminals	Operating force by pin plunger (max.)	Guard	Agency standard
AM5: QV switch	06: 6 A (Silver alloy)	1: Bottom COM, SPDT 2: Bottom COM, SPST-NC 3: Bottom COM, SPST-NO 4: Side COM, SPDT 5: Side COM, SPST-NC 6: Side COM, SPST-NO	0: Pin plunger 1: Short hinge lever 2: Hinge lever 3: Long hinge lever 4: Simulated roller lever 5: Short roller lever 6: Roller lever	A: .187 Quick-connect/ solder terminal C: .187 Quick-connect terminal	3: 0.49 N	R: Right hand guarded L: Left hand guarded	3: UL/CSA 6 × 10 ³ rated, VDE and SEMKO approved

* Please refer to the Standard Chart regarding Agency Standard

11A type

Ex. AM5 1 1 1 0 C 4 R 3 N

Type of switch	Contact rating	Terminals	Actuators	Terminals	Operating force by pin plunger (max.)	Guard	Agency standard	Contact
AM5: QV switch	11: 11 A (Silver alloy)	1: Bottom COM, SPDT 2: Bottom COM, SPST-NC 3: Bottom COM, SPST-NO 4: Side COM, SPDT 5: Side COM, SPST-NC 6: Side COM, SPST-NO	0: Pin plunger 1: Short hinge lever 2: Hinge lever 3: Long hinge lever 4: Simulated roller lever 5: Short roller lever 6: Roller lever	A: .187 Quick-connect/ solder terminal C: .187 Quick-connect terminal D: .250 Quick-connect terminal	4: 0.98 N	R: Right hand guarded L: Left hand guarded	3: UL/CSA 6 × 10 ³ rated, VDE and SEMKO approved	N: Cadmium free

* Please refer to the Standard Chart regarding Agency Standard

16A type

Ex. AM5 1 6 1 0 C 5 R 3 N

Type of switch	Contact rating	Terminals	Actuators	Terminals	Operating force by pin plunger (max.)	Guard	Agency standard	Contact
AM5: QV switch	16: 16 A (Silver alloy)	1: Bottom COM, SPDT 2: Bottom COM, SPST-NC 3: Bottom COM, SPST-NO 4: Side COM, SPDT 5: Side COM, SPST-NC 6: Side COM, SPST-NO	0: Pin plunger 1: Short hinge lever 2: Hinge lever 3: Long hinge lever 4: Simulated roller lever 5: Short roller lever 6: Roller lever	A: .187 Quick-connect/ solder terminal C: .187 Quick-connect terminal D: .250 Quick-connect terminal	5: 1.96 N 6: 2.94 N 7: 3.92 N	R: Right hand guarded L: Left hand guarded	3: UL/CSA 6 × 10 ³ rated, VDE and SEMKO approved	N: Cadmium free

Remarks: 1. Not every combination is available. Please refer to the table, "PRODUCT TYPES".
2. Please refer to the Standard Chart regarding Agency Standard

PRODUCT TYPES

0.1A type (Gold clad contact)

.187 Quick-connect terminal (Guardless)

1) Bottom COM terminal

Actuator	Operating force, Max.	Contact arrangement		
		SPDT	SPST-NC	SPST-NO
Pin plunger	0.49N	AM50010C33	AM50020C33	AM50030C33
	0.98N	AM50010C43	AM50020C43	AM50030C43
	1.96N	AM50010C53	AM50020C53	AM50030C53
Short hinge lever	0.59N	AM50011C33	AM50021C33	AM50031C33
	1.08N	AM50011C43	AM50021C43	AM50031C43
	2.16N	AM50011C53	AM50021C53	AM50031C53
Hinge lever	0.29N	AM50012C33	AM50022C33	AM50032C33
	0.59N	AM50012C43	AM50022C43	AM50032C43
	1.18N	AM50012C53	AM50022C53	AM50032C53
Long hinge lever	0.15N	AM50013C33	AM50023C33	AM50033C33
	0.29N	AM50013C43	AM50023C43	AM50033C43
	0.59N	AM50013C53	AM50023C53	AM50033C53
Simulated roller lever	0.29N	AM50014C33	AM50024C33	AM50034C33
	0.59N	AM50014C43	AM50024C43	AM50034C43
	1.18N	AM50014C53	AM50024C53	AM50034C53
Short roller lever	0.59N	AM50015C33	AM50025C33	AM50035C33
	1.08N	AM50015C43	AM50025C43	AM50035C43
	2.16N	AM50015C53	AM50025C53	AM50035C53
Roller lever	0.29N	AM50016C33	AM50026C33	AM50036C33
	0.59N	AM50016C43	AM50026C43	AM50036C43
	1.18N	AM50016C53	AM50026C53	AM50036C53

2-1) Side COM terminal

Actuator	Operating force, Max.	Contact arrangement		
		SPDT	SPST-NC	SPST-NO
Pin plunger	0.49N	AM50040C33	AM50050C33	AM50060C33
	0.98N	AM50040C43	AM50050C43	AM50060C43
	1.96N	AM50040C53	AM50050C53	AM50060C53
Short hinge lever	0.59N	AM50041C33	AM50051C33	AM50061C33
	1.08N	AM50041C43	AM50051C43	AM50061C43
	2.16N	AM50041C53	AM50051C53	AM50061C53
Hinge lever	0.29N	AM50042C33	AM50052C33	AM50062C33
	0.59N	AM50042C43	AM50052C43	AM50062C43
	1.18N	AM50042C53	AM50052C53	AM50062C53
Long hinge lever	0.15N	AM50043C33	AM50053C33	AM50063C33
	0.29N	AM50043C43	AM50053C43	AM50063C43
	0.59N	AM50043C53	AM50053C53	AM50063C53
Simulated roller lever	0.29N	AM50044C33	AM50054C33	AM50064C33
	0.59N	AM50044C43	AM50054C43	AM50064C43
	1.18N	AM50044C53	AM50054C53	AM50064C53
Short roller lever	0.59N	AM50045C33	AM50055C33	AM50065C33
	1.08N	AM50045C43	AM50055C43	AM50065C43
	2.16N	AM50045C53	AM50055C53	AM50065C53
Roller lever	0.29N	AM50046C33	AM50056C33	AM50066C33
	0.59N	AM50046C43	AM50056C43	AM50066C43
	1.18N	AM50046C53	AM50056C53	AM50066C53

AM5

2-2) Side COM terminal with right hand guard

Actuator	Operating force, Max.	Contact arrangement		
		SPDT	SPST-NC	SPST-NO
Pin plunger	0.49N	AM50040C3R3	AM50050C3R3	AM50060C3R3
	0.98N	AM50040C4R3	AM50050C4R3	AM50060C4R3
	1.96N	AM50040C5R3	AM50050C5R3	AM50060C5R3
Short hinge lever	0.59N	AM50041C3R3	AM50051C3R3	AM50061C3R3
	1.08N	AM50041C4R3	AM50051C4R3	AM50061C4R3
	2.16N	AM50041C5R3	AM50051C5R3	AM50061C5R3
Hinge lever	0.29N	AM50042C3R3	AM50052C3R3	AM50062C3R3
	0.59N	AM50042C4R3	AM50052C4R3	AM50062C4R3
	1.18N	AM50042C5R3	AM50052C5R3	AM50062C5R3
Long hinge lever	0.15N	AM50043C3R3	AM50053C3R3	AM50063C3R3
	0.29N	AM50043C4R3	AM50053C4R3	AM50063C4R3
	0.59N	AM50043C5R3	AM50053C5R3	AM50063C5R3
Simulated roller lever	0.29N	AM50044C3R3	AM50054C3R3	AM50064C3R3
	0.59N	AM50044C4R3	AM50054C4R3	AM50064C4R3
	1.18N	AM50044C5R3	AM50054C5R3	AM50064C5R3
Short roller lever	0.59N	AM50045C3R3	AM50055C3R3	AM50065C3R3
	1.08N	AM50045C4R3	AM50055C4R3	AM50065C4R3
	2.16N	AM50045C5R3	AM50055C5R3	AM50065C5R3
Roller lever	0.29N	AM50046C3R3	AM50056C3R3	AM50066C3R3
	0.59N	AM50046C4R3	AM50056C4R3	AM50066C4R3
	1.18N	AM50046C5R3	AM50056C5R3	AM50066C5R3

2-3) Side COM terminal with left hand guard

Actuator	Operating force, Max.	Contact arrangement		
		SPDT	SPST-NC	SPST-NO
Pin plunger	0.49N	AM50040C3L3	AM50050C3L3	AM50060C3L3
	0.98N	AM50040C4L3	AM50050C4L3	AM50060C4L3
	1.96N	AM50040C5L3	AM50050C5L3	AM50060C5L3
Short hinge lever	0.59N	AM50041C3L3	AM50051C3L3	AM50061C3L3
	1.08N	AM50041C4L3	AM50051C4L3	AM50061C4L3
	2.16N	AM50041C5L3	AM50051C5L3	AM50061C5L3
Hinge lever	0.29N	AM50042C3L3	AM50052C3L3	AM50062C3L3
	0.59N	AM50042C4L3	AM50052C4L3	AM50062C4L3
	1.18N	AM50042C5L3	AM50052C5L3	AM50062C5L3
Long hinge lever	0.15N	AM50043C3L3	AM50053C3L3	AM50063C3L3
	0.29N	AM50043C4L3	AM50053C4L3	AM50063C4L3
	0.59N	AM50043C5L3	AM50053C5L3	AM50063C5L3
Simulated roller lever	0.29N	AM50044C3L3	AM50054C3L3	AM50064C3L3
	0.59N	AM50044C4L3	AM50054C4L3	AM50064C4L3
	1.18N	AM50044C5L3	AM50054C5L3	AM50064C5L3
Short roller lever	0.59N	AM50045C3L3	AM50055C3L3	AM50065C3L3
	1.08N	AM50045C4L3	AM50055C4L3	AM50065C4L3
	2.16N	AM50045C5L3	AM50055C5L3	AM50065C5L3
Roller lever	0.29N	AM50046C3L3	AM50056C3L3	AM50066C3L3
	0.59N	AM50046C4L3	AM50056C4L3	AM50066C4L3
	1.18N	AM50046C5L3	AM50056C5L3	AM50066C5L3

Remarks: * Also .187 Quick-connect/solder terminal is available. When ordering, change the eighth digit of part number C to A.

<ex.> .187 Quick-connect terminal .187 Quick-connect/solder terminal
 AM50010C4 → AM50010A4

6A type (Silver alloy contact)

.187 Quick-connect terminal (Guardless)

1) Bottom COM terminal

Actuator	Operating force, Max.	Contact arrangement	Contact arrangement	
		SPDT	SPST-NC	SPST-NO
Pin plunger	0.49N	AM50610C33	AM50620C33	AM50630C33
Short hinge lever	0.59N	AM50611C33	AM50621C33	AM50631C33
Hinge lever	0.29N	AM50612C33	AM50622C33	AM50632C33
Long hinge lever	0.15N	AM50613C33	AM50623C33	AM50633C33
Simulated roller lever	0.29N	AM50614C33	AM50624C33	AM50634C33
Short roller lever	0.59N	AM50615C33	AM50625C33	AM50635C33
Roller lever	0.29N	AM50616C33	AM50626C33	AM50636C33

2-1) Side COM terminal

Actuator	Operating force, Max.	Contact arrangement	Contact arrangement	
		SPDT	SPST-NC	SPST-NO
Pin plunger	0.49N	AM50640C33	AM50650C33	AM50660C33
Short hinge lever	0.59N	AM50641C33	AM50651C33	AM50661C33
Hinge lever	0.29N	AM50642C33	AM50652C33	AM50662C33
Long hinge lever	0.15N	AM50643C33	AM50653C33	AM50663C33
Simulated roller lever	0.29N	AM50644C33	AM50654C33	AM50664C33
Short roller lever	0.59N	AM50645C33	AM50655C33	AM50665C33
Roller lever	0.29N	AM50646C33	AM50656C33	AM50666C33

2-2) Side COM terminal with right hand guard

Actuator	Operating force, Max.	Contact arrangement	Contact arrangement	
		SPDT	SPST-NC	SPST-NO
Pin plunger	0.49N	AM50640C3R3	AM50650C3R3	AM50660C3R3
Short hinge lever	0.59N	AM50641C3R3	AM50651C3R3	AM50661C3R3
Hinge lever	0.29N	AM50642C3R3	AM50652C3R3	AM50662C3R3
Long hinge lever	0.15N	AM50643C3R3	AM50653C3R3	AM50663C3R3
Simulated roller lever	0.29N	AM50644C3R3	AM50654C3R3	AM50664C3R3
Short roller lever	0.59N	AM50645C3R3	AM50655C3R3	AM50665C3R3
Roller lever	0.29N	AM50646C3R3	AM50656C3R3	AM50666C3R3

2-3) Side COM terminal with left hand guard

Actuator	Operating force, Max.	Contact arrangement	Contact arrangement	
		SPDT	SPST-NC	SPST-NO
Pin plunger	0.49N	AM50640C3L3	AM50650C3L3	AM50660C3L3
Short hinge lever	0.59N	AM50641C3L3	AM50651C3L3	AM50661C3L3
Hinge lever	0.29N	AM50642C3L3	AM50652C3L3	AM50662C3L3
Long hinge lever	0.15N	AM50643C3L3	AM50653C3L3	AM50663C3L3
Simulated roller lever	0.29N	AM50644C3L3	AM50654C3L3	AM50664C3L3
Short roller lever	0.59N	AM50645C3L3	AM50655C3L3	AM50665C3L3
Roller lever	0.29N	AM50646C3L3	AM50656C3L3	AM50666C3L3

Remarks: Also .187 Quick-connect/solder terminal is available. When ordering, change the eighth digit of part number C to A.

<ex.> .187 Quick-connect terminal .187 Quick-connect/solder terminal
 AM50610C4 → AM50610A4

AM5

11A type (Silver alloy contact)

.187 Quick-connect terminal (Guardless)

1) Bottom COM terminal

Actuator	Operating force, Max.	Contact arrangement		
		SPDT	SPST-NC	SPST-NO
Pin plunger	0.98N	AM51110C43N	AM51120C43N	AM51130C43N
Short hinge lever	1.08N	AM51111C43N	AM51121C43N	AM51131C43N
Hinge lever	0.59N	AM51112C43N	AM51122C43N	AM51132C43N
Long hinge lever	0.29N	AM51113C43N	AM51123C43N	AM51133C43N
Simulated roller lever	0.59N	AM51114C43N	AM51124C43N	AM51134C43N
Short roller lever	1.08N	AM51115C43N	AM51125C43N	AM51135C43N
Roller lever	0.59N	AM51116C43N	AM51126C43N	AM51136C43N

2-1) Side COM terminal

Actuator	Operating force, Max.	Contact arrangement		
		SPDT	SPST-NC	SPST-NO
Pin plunger	0.98N	AM51140C43N	AM51150C43N	AM51160C43N
Short hinge lever	1.08N	AM51141C43N	AM51151C43N	AM51161C43N
Hinge lever	0.59N	AM51142C43N	AM51152C43N	AM51162C43N
Long hinge lever	0.29N	AM51143C43N	AM51153C43N	AM51163C43N
Simulated roller lever	0.59N	AM51144C43N	AM51154C43N	AM51164C43N
Short roller lever	1.08N	AM51145C43N	AM51155C43N	AM51165C43N
Roller lever	0.59N	AM51146C43N	AM51156C43N	AM51166C43N

2-2) Side COM terminal with right hand guard

Actuator	Operating force, Max.	Contact arrangement		
		SPDT	SPST-NC	SPST-NO
Pin plunger	0.98N	AM51140C4R3N	AM51150C4R3N	AM51160C4R3N
Short hinge lever	1.08N	AM51141C4R3N	AM51151C4R3N	AM51161C4R3N
Hinge lever	0.59N	AM51142C4R3N	AM51152C4R3N	AM51162C4R3N
Long hinge lever	0.29N	AM51143C4R3N	AM51153C4R3N	AM51163C4R3N
Simulated roller lever	0.59N	AM51144C4R3N	AM51154C4R3N	AM51164C4R3N
Short roller lever	1.08N	AM51145C4R3N	AM51155C4R3N	AM51165C4R3N
Roller lever	0.59N	AM51146C4R3N	AM51156C4R3N	AM51166C4R3N

2-3) Side COM terminal with left hand guard

Actuator	Operating force, Max.	Contact arrangement		
		SPDT	SPST-NC	SPST-NO
Pin plunger	0.98N	AM51140C4L3N	AM51150C4L3N	AM51160C4L3N
Short hinge lever	1.08N	AM51141C4L3N	AM51151C4L3N	AM51161C4L3N
Hinge lever	0.59N	AM51142C4L3N	AM51152C4L3N	AM51162C4L3N
Long hinge lever	0.29N	AM51143C4L3N	AM51153C4L3N	AM51163C4L3N
Simulated roller lever	0.59N	AM51144C4L3N	AM51154C4L3N	AM51164C4L3N
Short roller lever	1.08N	AM51145C4L3N	AM51155C4L3N	AM51165C4L3N
Roller lever	0.59N	AM51146C4L3N	AM51156C4L3N	AM51166C4L3N

Remarks: 1. Also .187 Quick-connect/solder terminal is available. When ordering, change the eighth digit of part number C to A.

<ex.> .187 Quick-connect terminal .187 Quick-connect/solder terminal
 AM51110C4 → AM51110A4

2. .250 Quick-connect terminal is available. When ordering, change the eighth digit of part number C to D.

.250 Quick-connect terminal is available only for without guard type.

<ex.> .187 Quick-connect terminal .250 Quick-connect terminal
 AM51110C4 → AM51110D4

16A type (Silver alloy contact)

.187 Quick-connect terminal (Guardless)

1) Bottom COM terminal

Actuator	Operating force, Max.	Contact arrangement	Contact arrangement	
		SPDT	SPST-NC	SPST-NO
Pin plunger	1.96N	AM51610C53N	AM51620C53N	AM51630C53N
	2.94N	AM51610C63N	AM51620C63N	AM51630C63N
	3.92N	AM51610C73N	AM51620C73N	AM51630C73N
Short hinge lever	2.16N	AM51611C53N	AM51621C53N	AM51631C53N
	3.14N	AM51611C63N	AM51621C63N	AM51631C63N
	4.12N	AM51611C73N	AM51621C73N	AM51631C73N
Hinge lever	1.18N	AM51612C53N	AM51622C53N	AM51632C53N
	1.77N	AM51612C63N	AM51622C63N	AM51632C63N
	2.35N	AM51612C73N	AM51622C73N	AM51632C73N
Long hinge lever	0.59N	AM51613C53N	AM51623C53N	AM51633C53N
	0.88N	AM51613C63N	AM51623C63N	AM51633C63N
	1.18N	AM51613C73N	AM51623C73N	AM51633C73N
Simulated roller lever	1.18N	AM51614C53N	AM51624C53N	AM51634C53N
	1.77N	AM51614C63N	AM51624C63N	AM51634C63N
	2.35N	AM51614C73N	AM51624C73N	AM51634C73N
Short roller lever	1.18N	AM51615C53N	AM51625C53N	AM51635C53N
	3.14N	AM51615C63N	AM51625C63N	AM51635C63N
	4.12N	AM51615C73N	AM51625C73N	AM51635C73N
Roller lever	1.18N	AM51616C53N	AM51626C53N	AM51636C53N
	1.77N	AM51616C63N	AM51626C63N	AM51636C63N
	2.35N	AM51616C73N	AM51626C73N	AM51636C73N

2-1) Side COM terminal

Actuator	Operating force, Max.	Contact arrangement	Contact arrangement	
		SPDT	SPST-NC	SPST-NO
Pin plunger	1.96N	AM51640C53N	AM51650C53N	AM51660C53N
	2.94N	AM51640C63N	AM51650C63N	AM51660C63N
	3.92N	AM51640C73N	AM51650C73N	AM51660C73N
Short hinge lever	2.16N	AM51641C53N	AM51651C53N	AM51661C53N
	3.14N	AM51641C63N	AM51651C63N	AM51661C63N
	4.12N	AM51641C73N	AM51651C73N	AM51661C73N
Hinge lever	1.18N	AM51642C53N	AM51652C53N	AM51662C53N
	1.77N	AM51642C63N	AM51652C63N	AM51662C63N
	2.35N	AM51642C73N	AM51652C73N	AM51662C73N
Long hinge lever	0.59N	AM51643C53N	AM51653C53N	AM51663C53N
	0.88N	AM51643C63N	AM51653C63N	AM51663C63N
	1.18N	AM51643C73N	AM51653C73N	AM51663C73N
Simulated roller lever	1.18N	AM51644C53N	AM51654C53N	AM51664C53N
	1.77N	AM51644C63N	AM51654C63N	AM51664C63N
	2.35N	AM51644C73N	AM51654C73N	AM51664C73N
Short roller lever	2.16N	AM51645C53N	AM51655C53N	AM51665C53N
	3.14N	AM51645C63N	AM51655C63N	AM51665C63N
	4.12N	AM51645C73N	AM51655C73N	AM51665C73N
Roller lever	1.18N	AM51646C53N	AM51656C53N	AM51666C53N
	1.77N	AM51646C63N	AM51656C63N	AM51666C63N
	2.35N	AM51646C73N	AM51656C73N	AM51666C73N

AM5

2-2) Side COM terminal with right hand guard

Actuator	Operating force, Max.	Contact arrangement		
		SPDT	SPST-NC	SPST-NO
Pin plunger	1.96N	AM51640C5R3N	AM51650C5R3N	AM51660C5R3N
	2.94N	AM51640C6R3N	AM51650C6R3N	AM51660C6R3N
	3.92N	AM51640C7R3N	AM51650C7R3N	AM51660C7R3N
Short hinge lever	2.16N	AM51641C5R3N	AM51651C5R3N	AM51661C5R3N
	3.14N	AM51641C6R3N	AM51651C6R3N	AM51661C6R3N
	4.12N	AM51641C7R3N	AM51651C7R3N	AM51661C7R3N
Hinge lever	1.18N	AM51642C5R3N	AM51652C5R3N	AM51662C5R3N
	1.77N	AM51642C6R3N	AM51652C6R3N	AM51662C6R3N
	2.35N	AM51642C7R3N	AM51652C7R3N	AM51662C7R3N
Long hinge lever	0.59N	AM51643C5R3N	AM51653C5R3N	AM51663C5R3N
	0.88N	AM51643C6R3N	AM51653C6R3N	AM51663C6R3N
	1.18N	AM51643C7R3N	AM51653C7R3N	AM51663C7R3N
Simulated roller lever	1.18N	AM51644C5R3N	AM51654C5R3N	AM51664C5R3N
	1.77N	AM51644C6R3N	AM51654C6R3N	AM51664C6R3N
	2.35N	AM51644C7R3N	AM51654C7R3N	AM51664C7R3N
Short roller lever	2.16N	AM51645C5R3N	AM51655C5R3N	AM51665C5R3N
	3.14N	AM51645C6R3N	AM51655C6R3N	AM51665C6R3N
	4.12N	AM51645C7R3N	AM51655C7R3N	AM51665C7R3N
Roller lever	1.18N	AM51646C5R3N	AM51656C5R3N	AM51666C5R3N
	1.77N	AM51646C6R3N	AM51656C6R3N	AM51666C6R3N
	2.35N	AM51646C7R3N	AM51656C7R3N	AM51666C7R3N

2-3) Side COM terminal with left hand guard

Actuator	Operating force, Max.	Contact arrangement		
		SPDT	SPST-NC	SPST-NO
Pin plunger	1.96N	AM51640C5L3N	AM51650C5L3N	AM51660C5L3N
	2.94N	AM51640C6L3N	AM51650C6L3N	AM51660C6L3N
	3.92N	AM51640C7L3N	AM51650C7L3N	AM51660C7L3N
Short hinge lever	2.16N	AM51641C5L3N	AM51651C5L3N	AM51661C5L3N
	3.14N	AM51641C6L3N	AM51651C6L3N	AM51661C6L3N
	4.12N	AM51641C7L3N	AM51651C7L3N	AM51661C7L3N
Hinge lever	1.18N	AM51642C5L3N	AM51652C5L3N	AM51662C5L3N
	1.77N	AM51642C6L3N	AM51652C6L3N	AM51662C6L3N
	2.35N	AM51642C7L3N	AM51652C7L3N	AM51662C7L3N
Long hinge lever	0.59N	AM51643C5L3N	AM51653C5L3N	AM51663C5L3N
	0.88N	AM51643C6L3N	AM51653C6L3N	AM51663C6L3N
	1.18N	AM51643C7L3N	AM51653C7L3N	AM51663C7L3N
Simulated roller lever	1.18N	AM51644C5L3N	AM51654C5L3N	AM51664C5L3N
	1.77N	AM51644C6L3N	AM51654C6L3N	AM51664C6L3N
	2.35N	AM51644C7L3N	AM51654C7L3N	AM51664C7L3N
Short roller lever	2.16N	AM51645C5L3N	AM51655C5L3N	AM51665C5L3N
	3.14N	AM51645C6L3N	AM51655C6L3N	AM51665C6L3N
	4.12N	AM51645C7L3N	AM51655C7L3N	AM51665C7L3N
Roller lever	1.18N	AM51646C5L3N	AM51656C5L3N	AM51666C5L3N
	1.77N	AM51646C6L3N	AM51656C6L3N	AM51666C6L3N
	2.35N	AM51646C7L3N	AM51656C7L3N	AM51666C7L3N

Remarks: 1. .187 Quick-connect/solder terminal is available. When ordering, change the eighth digit of part number C to A.

<ex.> .187 Quick-connect terminal .187 Quick-connect/solder terminal
 AM51610C5 → AM51610A5

2. .250 Quick-connect terminal is available. When ordering, change the eighth digit of part number C to D.

<ex.> .187 Quick-connect terminal .250 Quick-connect terminal
 AM51610C5 → AM51610D5

DATA

Gold-clad type

Range of low-level current voltage

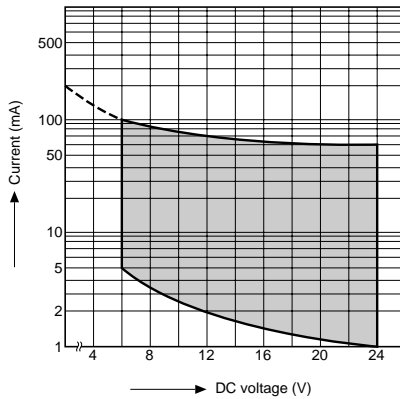

SPECIFICATIONS

1. Contact rating

Type		Voltage	Resistive load (cos=1)	Inductive load (cos nearly equal 0.6 to 0.7)
Gold clad contact	0.1A type	250V AC	0.1A	0.1A
		125V AC	0.1A	0.1A
		30V DC	0.1A	0.1A
Silver alloy contact	6A type	250V AC	6A	3A
		125V AC	6A	3A
		125V DC	0.5A	0.5A
	11A type	250V AC	11A	6A
		125V AC	11A	6A
		125V DC	0.6A	0.6A
	16A type	250V AC	16A	10A
		125V AC	16A	10A
		125V DC	0.6A	0.6A
Gold clad contact for low level circuit		6V DC	5mA	—
		12V DC	2mA	—
		24V DC	1mA	—

Remark: The inductive load for DC should have a time constant of 7 ms or less.

2. Characteristics

Type		16, 11, 6A type (Silver alloy)	0.1A type (Gold clad)
Expected life (min.)	Mechanical	10 ⁷ operations (at 60 cpm)	
	Electrical	10 ⁵ Operations (at rated load 20 cpm)	10 ⁵ operations (at rated load) 2 × 10 ⁶ operations (at low-level circuit rating)
Insulation resistance		100MΩ (at 500V DC)	
Dielectric strength	Between terminals	1,000Vrms for 1 min.	
	Between terminals and other exposed metal parts	2,000Vrms for 1 min.	
	Between terminals and ground	2,000Vrms for 1 min.	
Contact resistance (initial)		50mΩ (by voltage drop at 1A 6 to 8V DC)	50mΩ (by voltage drop at 0.1A 6 to 8V DC)
Vibration resistance (by pin plunger)		10 to 55Hz at simple amplitude of 0.75mm (Contact opening: max. 1msec.)	
Shock resistance (by pin plunger) (contact opening: max. 1msec.)		O.F. 0.49N max. type Min. 98m/s ² O.F. 0.98N max. type Min. 196m/s ² O.F. 1.96N to 3.92N max. type Min. 294m/s ²	O.F. 0.15N to 0.49N max. type Min. 98m/s ² O.F. 0.98N max. type Min. 196m/s ² O.F. 1.96N max. type Min. 294m/s ²
Allowable operating speed		0.1 to 1,000mm/sec. (at pin plunger)	
Maximum operating cycle rate		600cpm	
Ambient temperature		-25 to +105°C (Not freezing below 0°C)	
Weight		6.3g	

AM5

3. Operating characteristics

Pin plunger

7th digit of part No.	3	4	5	6	7
Operating force, max.	0.49N	0.98N	1.96N	2.94N	3.92N
Release force, min.	0.12N	0.25N	0.49N	0.74N	0.98N
Pretravel, max. mm	1.4				
Movement differential, max. mm	0.4				
Overtravel, min. mm	1.0				
Operating position mm	14.7±0.4				

Short hinge lever

7th digit of part No.	3	4	5	6	7
Operating force, max.	0.59N	1.08N	2.16N	3.14N	4.12N
Release force, min.	0.098N	0.20N	0.39N	0.59N	0.78N
Pretravel, max. mm	1.6				
Movement differential, max. mm	0.5				
Overtravel, min. mm	0.9				
Operating position mm	15.3±0.5				

Hinge lever

7th digit of part No.	3	4	5	6	7
Operating force, max.	0.29N	0.59N	1.18N	1.77N	2.35N
Release force, min.	0.049N	0.098N	0.20N	0.29N	0.39N
Pretravel, max. mm	3.2				
Movement differential, max. mm	1.0				
Overtravel, min. mm	1.4				
Operating position mm	15.3±1.0				

Long hinge lever

7th digit of part No.	3	4	5	6	7
Operating force, max.	0.15N	0.29N	0.59N	0.88N	1.18N
Release force, min.	0.025N	0.049N	0.098N	0.15N	0.20N
Pretravel, max. mm	7.5				
Movement differential, max. mm	2.0				
Overtravel, min. mm	2.2				
Operating position mm	15.3±2.6				

Simulated roller lever

7th digit of part No.	3	4	5	6	7
Operating force, max.	0.29N	0.59N	1.18N	1.77N	2.35N
Release force, min.	0.049N	0.098N	0.20N	0.29N	0.39N
Pretravel, max. mm	3.2				
Movement differential, max. mm	1.0				
Overtravel, min. mm	1.4				
Operating position mm	18.5±1.0				

Short roller lever

7th digit of part No.	3	4	5	6	7
Operating force, max.	0.59N	1.08N	2.16N	3.14N	4.12N
Release force, min.	0.098N	0.20N	0.39N	0.59N	0.78N
Pretravel, max. mm	1.6				
Movement differential, max. mm	0.5				
Overtravel, min. mm	0.9				
Operating position mm	20.7±0.5				

Roller lever

7th digit of part No.	3	4	5	6	7
Operating force, max.	0.29N	0.59N	1.18N	1.77N	2.35N
Release force, min.	0.049N	0.098N	0.20N	0.29N	0.39N
Pretravel, max. mm	3.2				
Movement differential, max. mm	1.0				
Overtravel, min. mm	1.4				
Operating position mm	20.7±1.0				

DIMENSIONS

1. Pin plunger
Bottom COM terminal
(Guardless)



.187 Quick-connect terminal

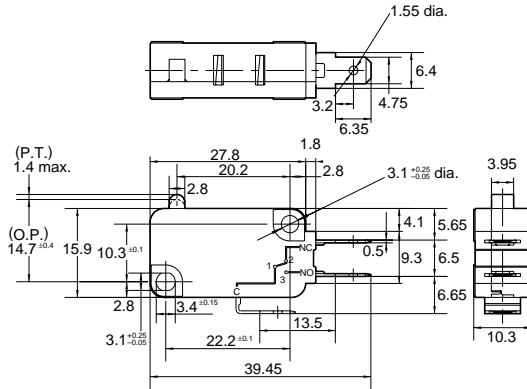

.250 Quick-connect terminal

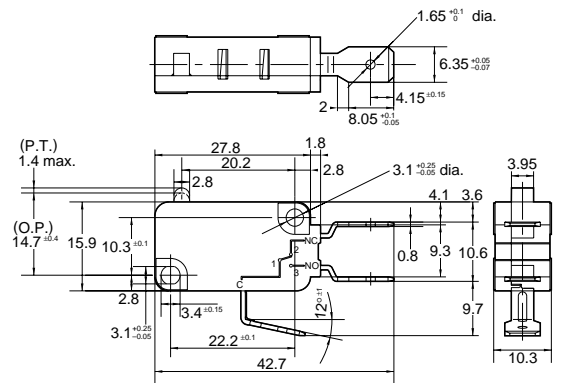

Side COM terminal
(Guardless)



.187 Quick-connect terminal

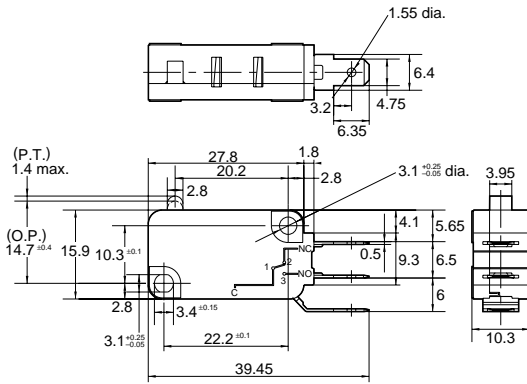

.250 Quick-connect terminal

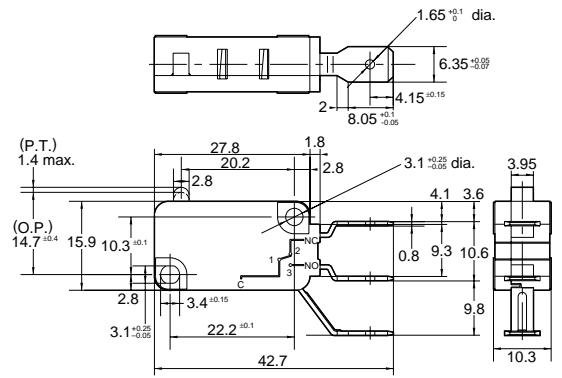

Side COM terminal
(Right hand guarded)



.187 Quick-connect terminal

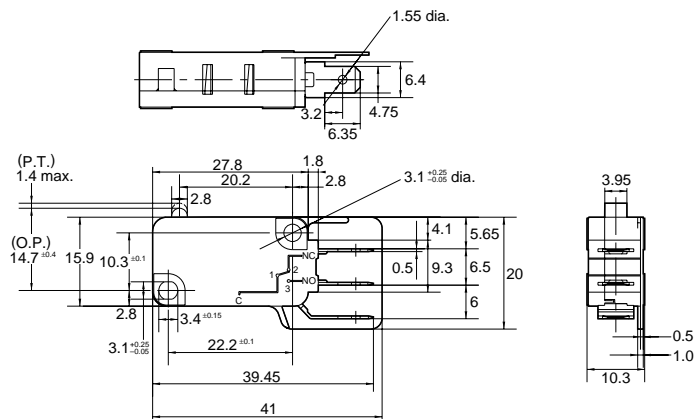

AM5

Side COM terminal
(Left hand guarded)

mm General tolerance: ± 0.25



.187 Quick-connect terminal

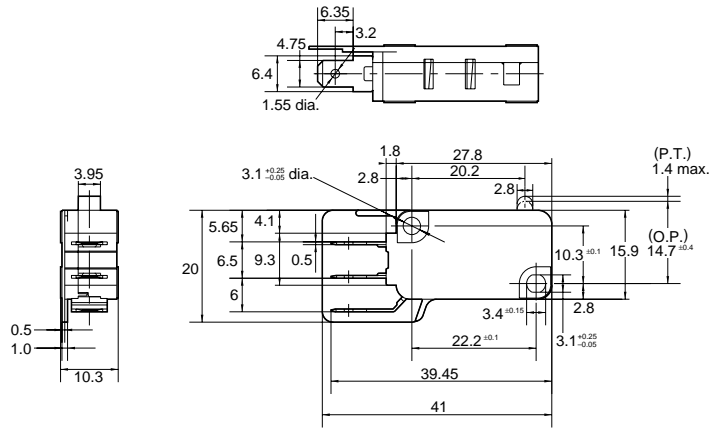

2. Short hinge lever

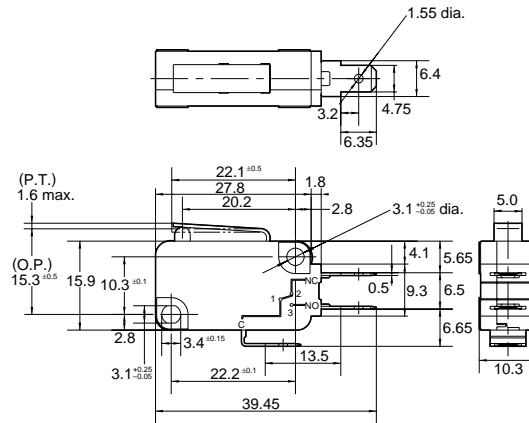

The dimensions other than drawn above are same as pin plunger type.

3. Hinge lever

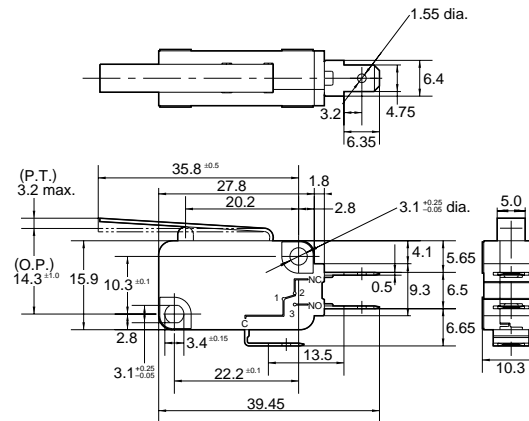

The dimensions other than drawn above are same as pin plunger type.

4. Long hinge lever

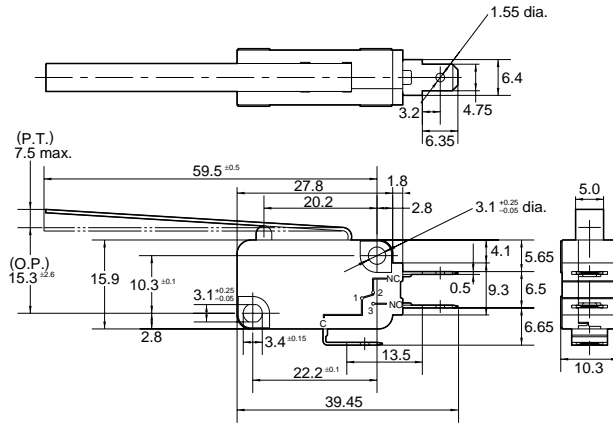

The dimensions other than drawn above are same as pin plunger type.

5. Simulated roller lever

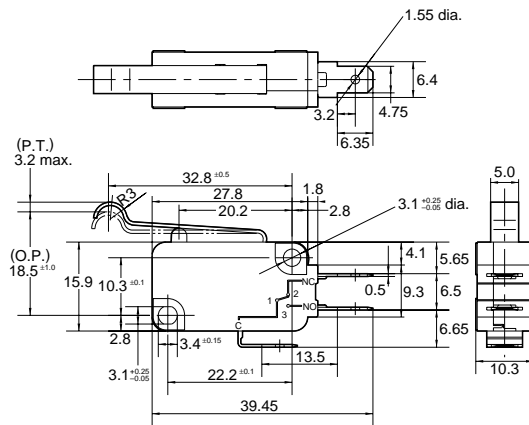

The dimensions other than drawn above are same as pin plunger type.

6. Short roller lever

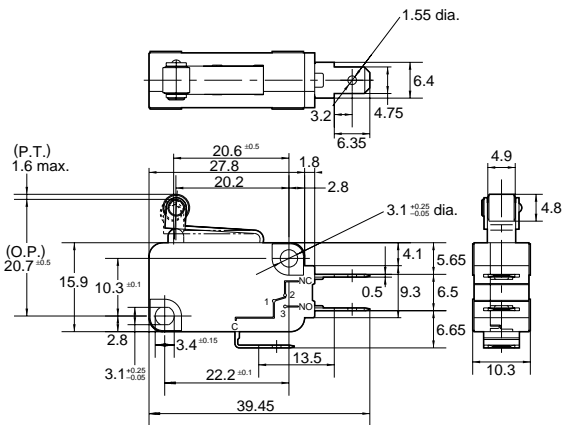

The dimensions other than drawn above are same as pin plunger type.

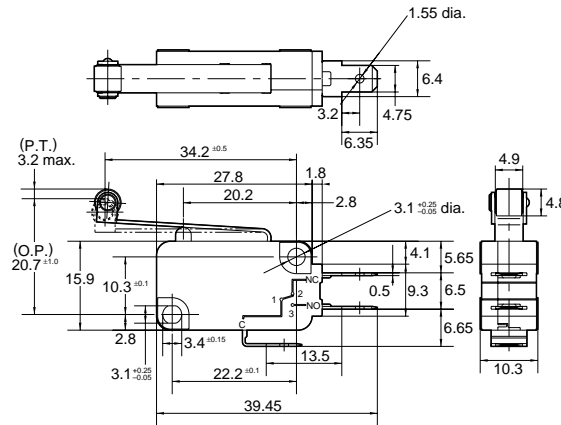

The dimensions other than drawn above are same as pin plunger type.

NOTES

1. Fastening of the switch body

- 1) Use flat filister head M3 screws to mount switches with less than a 0.49 N·m torque. Use of screws washers or adhesive lock is recommended to prevent loosening of the screws.
- 2) Check insulation distance between ground and each terminal.
- 3) When the operation object is in the free position, force should not be applied directly to the actuator or pin plunger. Also force should be applied to the pin plunger from vertical direction to the switch.
- 4) The standard value of overtravel should be the range of 70% to 100% of the rated O.T. value.

2. Soldering operations

Soldering should be accomplished in less than 5 seconds, with a 60 watt iron. Care should be taken not to apply force to the terminal during soldering.

3. Variance of operating characteristics

When specifying the switch, allow +20% to the listed operating and release forces.

4. Environment

Avoid using the switches in the following conditions;

- In corrosive gases, such as silicon gas
- In a dusty environment

5. For switching of inductive loads (relays, solenoids, etc.)

- 1) In order to prevent damage to contacts due to the occurrence of arcing, an arc absorbing circuit should be applied.
- 2) Care should be taken that occurrence in AC load possibly shorten the expected life.

6. Please assure the quality and reliability of the switch under the actual service condition.

7. It is recommended to use Gold clad contact type in use of low-level circuit rating.

8. Cover and body are press-fitted. Once it is taken apart, it may cause change of characteristics.

9. Cover and body are press-fitted. Once it is taken apart, it may cause change of characteristics.

USE OF CONNECTOR

The .187 Quick-connect terminal and .250 Quick-connect terminal accept the all kinds of 1 polarity connectors and the "Positive Lock" connectors. Please contact the manufacturers directly.

• receptacle terminal

.250 series

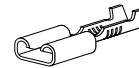

.187 series



• "Positive Lock" connector. (equipped with the lock construction of low insertion type)

.187 type
(1 polarity)

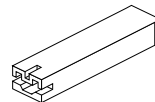

.187 type
(2 polarities)

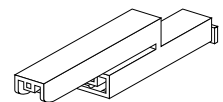

.250 type
(1 polarity)

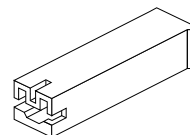

.187 type
(3 polarities)

