

256K-BIT CMOS STATIC RAM
32K-WORD BY 8-BIT**Description**

The μ PD43256B is a high speed, low power, and 262,144 bits (32,768 words by 8 bits) CMOS static RAM. Battery backup is available (L, LL, A, and B versions). And A and B versions are wide voltage operations. The μ PD43256B is packed in 28-pin plastic DIP, 28-pin plastic SOP, and 32-pin plastic TSOP(I).

Features

- 32,768 words by 8 bits organization
- Fast access time: 55 ns (MAX.)
- Wide voltage range (A version: $V_{CC} = 3.0$ to 5.5 V, B version: $V_{CC} = 2.7$ to 5.5 V)
- 2 V data retention
- \overline{OE} input for easy application

Part number	Access time ns (MAX.)	Operating supply voltage V	Operating temperature °C	Standby supply current μ A (MAX.)	^{Note 1} Data retention supply current μ A (MAX.)
μ PD43256B	55, 70, 85	4.5 to 5.5	0 to 70	2000	—
μ PD43256B-L	55, 70, 85			100	15
μ PD43256B-LL	55, 70, 85			50	3
μ PD43256B-A	85 ^{Note 2} , 100, 120	3.0 to 5.5			
μ PD43256B-B	85 ^{Note 2} , 100, 120	2.7 to 5.5			

Note 1. $T_A \leq 40$ °C, $V_{CC} = 3$ V

2. $V_{CC} = 4.5$ to 5.5 V

The information in this document is subject to change without notice.

The mark \star shows revised points.

★ Ordering Information (1/2)

Part number	Package	Access time ns (MAX.)	Operating supply voltage V	Operating temperature °C	Remark	
μPD43256BCZ-55	28-pin plastic DIP (600 mil)	55	4.5 to 5.5	0 to 70	—	
μPD43256BCZ-70		70				
μPD43256BCZ-85		85				
μPD43256BCZ-55L		55			L Version	
μPD43256BCZ-70L		70				
μPD43256BCZ-85L		85				
μPD43256BCZ-55LL		55				LL Version
μPD43256BCZ-70LL		70				
μPD43256BCZ-85LL		85				
μPD43256BGU-55L	28-pin plastic SOP (450 mil)	55	3.0 to 5.5	0 to 70	L Version	
μPD43256BGU-70L		70				
μPD43256BGU-85L		85				
μPD43256BGU-55LL		55			LL Version	
μPD43256BGU-70LL		70				
μPD43256BGU-85LL		85				
μPD43256BGU-A10		100			A Version	
μPD43256BGU-A12		120				
μPD43256BGU-B10		100			B Version	
μPD43256BGU-B12	120					

Ordering Information (2/2)

★

Part number	Package	Access time ns (MAX.)	Operating supply voltage V	Operating temperature °C	Remark		
μPD43256BGX-55L-EJA	32-pin plastic TSOP(I)(600 mil) (Normal bent)	55	4.5 to 5.5	0 to 70	L Version		
μPD43256BGX-70L-EJA		70					
μPD43256BGX-85L-EJA		85					
μPD43256BGX-55LL-EJA		55			LL Version		
μPD43256BGX-70LL-EJA		70					
μPD43256BGX-85LL-EJA		85					
μPD43256BGX-A10-EJA		100	3.0 to 5.5		A Version		
μPD43256BGX-A12-EJA		120	2.7 to 5.5		B Version		
μPD43256BGX-B10-EJA		100					
μPD43256BGX-B12-EJA		120					
μPD43256BGX-55L-EKA		32-pin plastic TSOP(I)(600 mil) (Reverse bent)	55		4.5 to 5.5	0 to 70	L Version
μPD43256BGX-70L-EKA			70				
μPD43256BGX-85L-EKA	85						
μPD43256BGX-55LL-EKA	55		LL Version				
μPD43256BGX-70LL-EKA	70						
μPD43256BGX-85LL-EKA	85						
μPD43256BGX-A10-EKA	100		3.0 to 5.5	A Version			
μPD43256BGX-A12-EKA	120		2.7 to 5.5	B Version			
μPD43256BGX-B10-EKA	100						
μPD43256BGX-B12-EKA	120						

Pin Configuration (Marking Side)

**28-pin plastic DIP (600 mil)
28-pin plastic SOP (450 mil)**

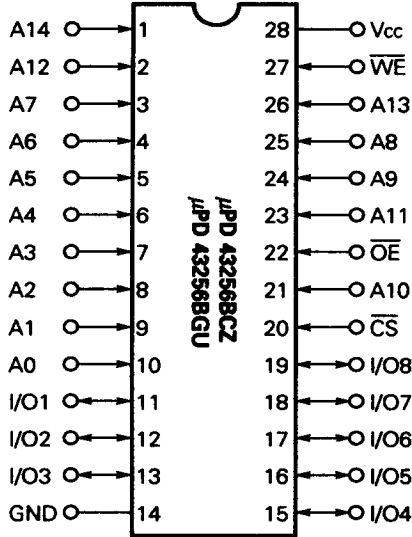

**32-pin plastic TSOP (I) (600 mil)
(Normal bent)**

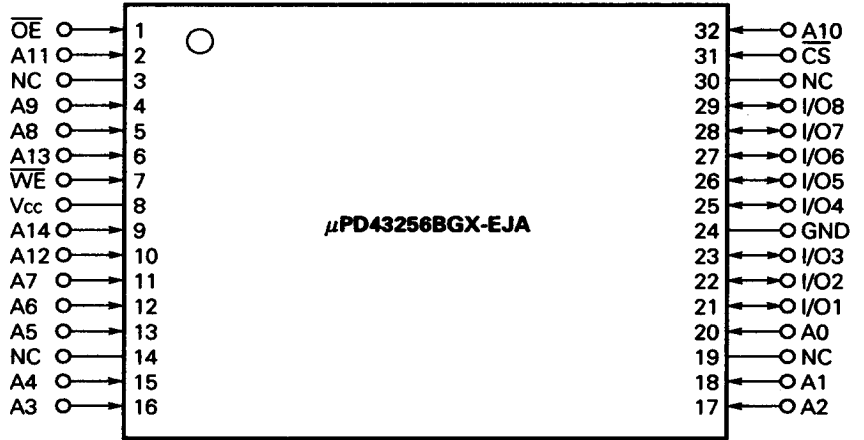

**32-pin plastic TSOP (I) (600 mil)
(Reverse bent)**

- A0 - A14 : Address inputs
- I/O1 - I/O8 : Data inputs/outputs
- CS : Chip Select
- WE : Write Enable
- OE : Output Enable
- Vcc : Power supply
- GND : Ground
- NC : No connection

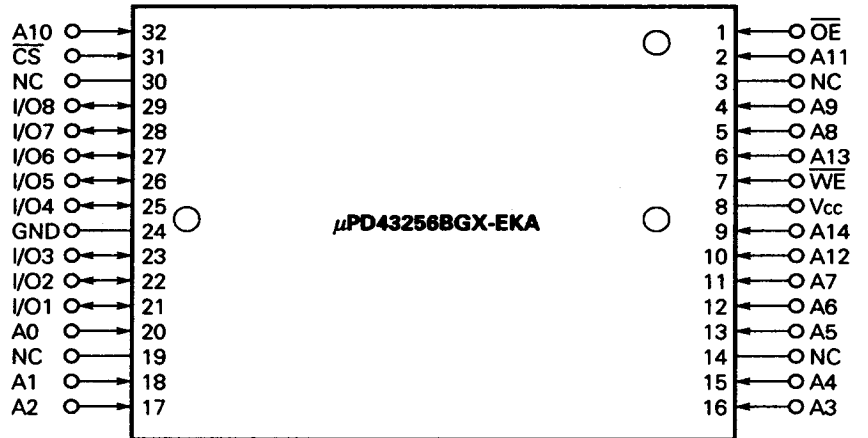

Block Diagram

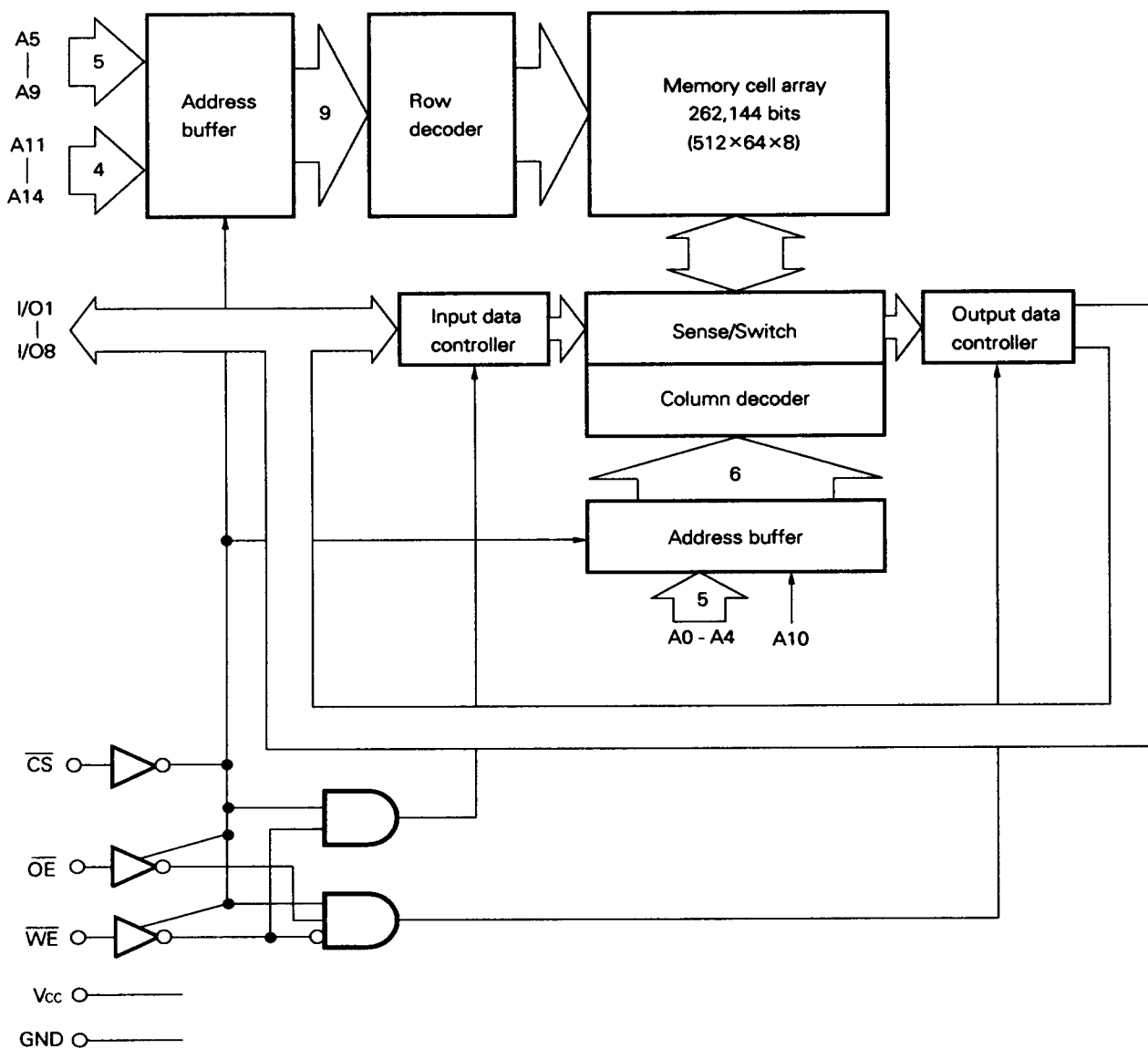

Truth Table

\overline{CS}	\overline{OE}	\overline{WE}	Mode	I/O	Supply current
H	X	X	Not selected	High impedance	I_{sa}
L	H	H	Output disable		
L	X	L	Write	D_{IN}	I_{cca}
L	L	H	Read	D_{OUT}	

Remark X : Don't care

Electrical Characteristics

★ **Absolute Maximum Ratings**

Parameter	Symbol	Rating	Unit
Supply voltage	V _{CC}	-0.5 ^{Note} to +7.0	V
Input/Output voltage	V _I	-0.5 ^{Note} to V _{CC} + 0.5	V
Operating ambient temperature	T _A	0 to 70	°C
Storage temperature	T _{stg}	-55 to +125	°C

Note -3.0 V (MIN.) (Pulse width 50 ns)

Caution Exposing the device to stress above those listed in absolute maximum ratings could cause permanent damage. The device is not meant to be operated under conditions outside the limits described in the operational sections of this characteristics. Exposure to absolute maximum rating conditions for extended periods may affect device reliability.

★ **Recommended Operating Conditions**

Parameter	Symbol	μPD43256B μPD43256B-L μPD43256B-LL		μPD43256B-A		μPD43256B-B		Unit
		MIN.	MAX.	MIN.	MAX.	MIN.	MAX.	
Supply voltage	V _{CC}	4.5	5.5	3.0	5.5	2.7	5.5	V
High level input voltage	V _{IH}	2.2	V _{CC} + 0.5	2.2	V _{CC} + 0.5	2.2	V _{CC} + 0.5	V
Low level input voltage	V _{IL}	-0.3 ^{Note}	+0.8	-0.3 ^{Note}	+0.5	-0.3 ^{Note}	+0.5	V
Operating ambient temperature	T _A	0	70	0	70	0	70	°C

Note -3.0 V (MIN.) (Pulse width 50 ns)

DC Characteristics (Recommended operating conditions unless otherwise noted) (1/2)

Parameter	Symbol	Test conditions	μPD43256B			μPD43256B-L			μPD43256B-LL			Unit
			MIN.	TYP.	MAX.	MIN.	TYP.	MAX.	MIN.	TYP.	MAX.	
Input leakage current	I_{LI}	$V_{IN} = 0\text{ V to }V_{CC}$	-1.0		+1.0	-1.0		+1.0	-1.0		+1.0	μA
I/O leakage current	I_{LO}	$V_{IO} = 0\text{ V to }V_{CC}$ $\overline{OE} = V_{IH}$ or $\overline{CS} = V_{IH}$ or $\overline{WE} = V_{IL}$	-1.0		+1.0	-1.0		+1.0	-1.0		+1.0	μA
Operating supply current	I_{CCA1}	$\overline{CS} = V_{IL}$, Minimum cycle time, $I_{IO} = 0\text{ mA}$	μPD43256B-55			μPD43256B-70			μPD43256B-85			mA
					50			50			50	
			45			45			45			
	I_{CCA2}	$\overline{CS} = V_{IL}$, $I_{IO} = 0\text{ mA}$			10			10			10	
	I_{CCA3}	$\overline{CS} \leq 0.2\text{ V}$, Cycle = 1 MHz, $I_{IO} = 0\text{ mA}$ $V_{IL} \leq 0.2\text{ V}$, $V_{IH} \geq V_{CC} - 0.2\text{ V}$			10			10			10	
Standby supply current	I_{SB}	$\overline{CS} = V_{IH}$			5			3			3	mA
	I_{SB1}	$\overline{CS} \geq V_{CC} - 0.2\text{ V}$		20	2000		2.0	100		1.0	50	μA
High level output voltage	V_{OH1}	$I_{OH} = -1.0\text{ mA}$	2.4			2.4			2.4			V
	V_{OH2}	$I_{OH} = -0.1\text{ mA}$	$V_{CC}-0.5$			$V_{CC}-0.5$			$V_{CC}-0.5$			
Low level output voltage	V_{OL}	$I_{OL} = 2.1\text{ mA}$			0.4			0.4			0.4	V

- Remark 1. V_{IN} : Input voltage
 2. These DC Characteristics are in common regardless of package types.

★ DC Characteristics (Recommended operating conditions unless otherwise noted) (2/2)

Parameter	Symbol	Test conditions	μPD43256B-A			μPD43256B-B			Unit	
			MIN.	TYP.	MAX.	MIN.	TYP.	MAX.		
Input leakage current	I_{II}	$V_{IN} = 0\text{ V to }V_{CC}$	-1.0		+1.0	-1.0		+1.0	μA	
I/O leakage current		$V_{VO} = 0\text{ V to }V_{CC}$ $\overline{CS} = V_{IH}$ or $\overline{WE} = V_{IL}$ or $\overline{OE} = V_{IH}$	-1.0		+1.0	-1.0		+1.0	μA	
Operating supply current	I_{CCA1}	$\overline{CS} = V_{IL}$, Minimum cycle time, $I_{VO} = 0\text{ mA}$	μPD43256B-A10			μPD43256B-B			mA	
			μPD43256B-A12			45				—
			μPD43256B-B10			—				45
			μPD43256B-B12			—				20
	I_{CCA2}	$\overline{CS} = V_{IL}$, $I_{VO} = 0\text{ mA}$				10			10	
			$V_{CC} \leq 3.3\text{ V}$			—			5	
I_{CCA3}	$\overline{CS} \leq 0.2\text{ V}$, Cycle = 1 MHz, $I_{VO} = 0\text{ mA}$, $V_{IL} \leq 0.2\text{ V}$, $V_{IH} \geq V_{CC} - 0.2\text{ V}$				10			10		
			$V_{CC} \leq 3.3\text{ V}$			—			5	
Standby supply current	I_{SB}	$\overline{CS} = V_{IH}$				3			3	
			$V_{CC} \leq 3.3\text{ V}$			—			2	
	I_{SB1}	$\overline{CS} \geq V_{CC} - 0.2\text{ V}$				1.0			50	
			$V_{CC} \leq 3.3\text{ V}$			—			0.5	25
High level output voltage	V_{OH1}	$I_{OH} = -1.0\text{ mA}$, $V_{CC} \geq 4.5\text{ V}$	2.4			2.4			V	
		$I_{OH} = -0.5\text{ mA}$, $V_{CC} < 4.5\text{ V}$	2.4			2.4				
	V_{OH2}	$I_{OH} = -0.1\text{ mA}$	—			—				
		$I_{OH} = -0.02\text{ mA}$	$V_{CC}-0.1$			$V_{CC}-0.1$				
Low level output voltage	V_{OL}	$I_{OL} = 2.1\text{ mA}$, $V_{CC} \geq 4.5\text{ V}$				0.4			V	
		$I_{OL} = 1.0\text{ mA}$, $V_{CC} < 4.5\text{ V}$				0.4				
	V_{OL1}	$I_{OL} = 0.02\text{ mA}$				0.1				

Remark 1. V_{IN} : Input voltage

2. These DC Characteristics are in common regardless of package types.

Capacitance ($T_A = 25\text{ }^\circ\text{C}$, $f = 1\text{ MHz}$)

Parameter	Symbol	Test conditions	MIN.	TYP.	MAX.	Unit
Input capacitance	C_{IN}	$V_{IN} = 0\text{ V}$			5	pF
Input/Output capacitance	C_{VO}	$V_{VO} = 0\text{ V}$			8	pF

Remark 1. V_{IN} : Input voltage

2. These parameters are periodically sampled and not 100 % tested.

AC Characteristics (Recommended operating conditions unless otherwise noted)

AC Test Conditions

Input waveform (Rise/fall time ≤ 5 ns)

Input pulse levels

0.8 V to 2.2 V : μPD43256B, μPD43256B-L, μPD43256B-LL

0.5 V to 2.2 V : μPD43256B-A, μPD43256B-B

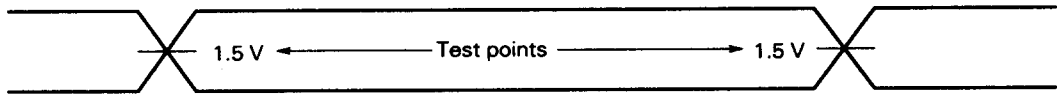

Output waveform

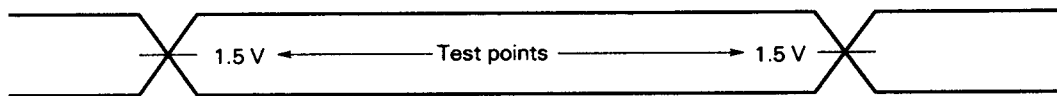

Output load

AC characteristics with notes should be measured with the output load shown in Fig. 1 and Fig. 2.

Fig. 1

(For t_{AA} , t_{ACS} , t_{OE} , t_{OH})

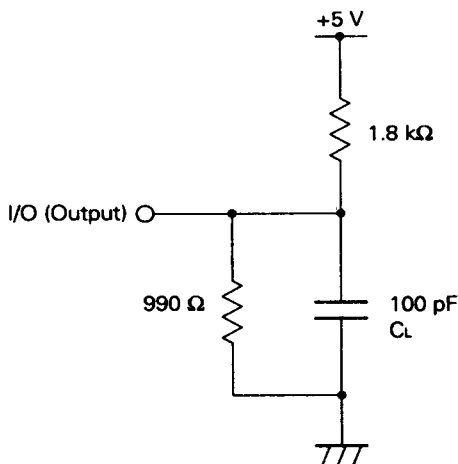
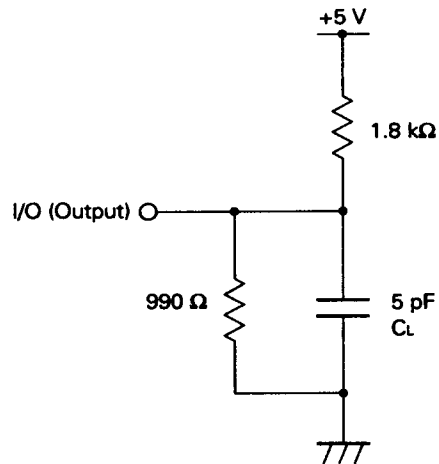

Fig. 2

(For t_{CHZ} , t_{CLZ} , t_{OHZ} , t_{OLZ} , t_{WHZ} , t_{OW})



Remark C_L includes capacitances of the probe and jig, and stray capacitances.

★ Read Cycle (1/2)

Parameter	Symbol	V _{CC} ≥ 4.5 V						Unit	Condition
		μPD43256B-55		μPD43256B-70		μPD43256B-85 μPD43256B-A10 μPD43256B-A12 μPD43256B-B10 μPD43256B-B12			
		MIN.	MAX.	MIN.	MAX.	MIN.	MAX.		
Read cycle time	t _{RC}	55		70		85		ns	
Address access time	t _{AA}		55		70		85	ns	Note 1
CS access time	t _{ACS}		55		70		85	ns	
OE to output valid	t _{OE}		30		35		40	ns	
Output hold from address change	t _{OH}	10		10		10		ns	
CS to output in low impedance	t _{CLZ}	10		10		10		ns	Note 2
OE to output in low impedance	t _{OLZ}	5		5		5		ns	
CS to output in high impedance	t _{CHZ}		30		30		30	ns	
OE to output in high impedance	t _{OHZ}		30		30		30	ns	

Note 1. See the output load shown in Fig. 1.

2. See the output load shown in Fig. 2.

Read Cycle (2/2)

Parameter	Symbol	V _{CC} ≥ 3.0 V				V _{CC} ≥ 2.7 V				Unit	Condition
		μPD43256B-A10		μPD43256B-A12		μPD43256B-B10		μPD43256B-B12			
		MIN.	MAX.	MIN.	MAX.	MIN.	MAX.	MIN.	MAX.		
Read cycle time	t _{RC}	100		120		100		120		ns	
Address access time	t _{AA}		100		120		100		120	ns	Note 1
CS access time	t _{ACS}		100		120		100		120	ns	
OE access time	t _{OE}		60		60		60		60	ns	
Output hold from address change	t _{OH}	10		10		10		10		ns	
CS to output in low impedance	t _{CLZ}	10		10		10		10		ns	Note 2
OE to output in low impedance	t _{OLZ}	5		5		5		5		ns	
CS to output in high impedance	t _{CHZ}		35		40		35		40	ns	
OE to output in high impedance	t _{OHZ}		35		40		35		40	ns	

Note 1. See the output load shown in Fig. 1.

2. See the output load shown in Fig. 2.

Read Cycle Timing Chart

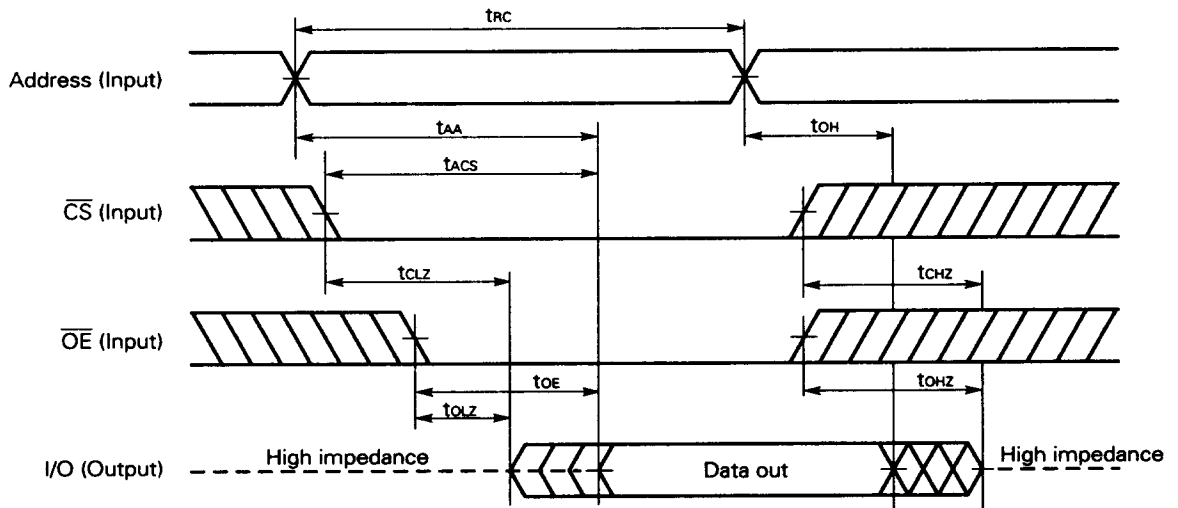

Remark In read cycle, \overline{WE} should be fixed to high level.

★ Write Cycle (1/2)

Parameter	Symbol	V _{CC} ≥ 4.5 V						Unit	Condition
		μPD43256B-55		μPD43256B-70		μPD43256B-85 μPD43256B-A10 μPD43256B-A12 μPD43256B-B10 μPD43256B-B12			
		MIN.	MAX.	MIN.	MAX.	MIN.	MAX.		
Write cycle time	t _{wc}	55		70		85		ns	
$\overline{\text{CS}}$ to end of write	t _{cw}	50		60		70		ns	
Address valid to end of write	t _{aw}	50		60		70		ns	
Write pulse width	t _{wp}	45		55		65		ns	
Data valid to end of write	t _{dw}	30		30		35		ns	
Data hold time	t _{dh}	0		0		0		ns	
Address setup time	t _{as}	0		0		0		ns	
Write recovery time	t _{wr}	5		5		5		ns	
$\overline{\text{WE}}$ to output in high impedance	t _{whz}		30		30		30	ns	Note
Output active from end of write	t _{ow}	10		10		10		ns	

Note See the output load shown in Fig. 2.

Write Cycle (2/2)

Parameter	Symbol	V _{CC} ≥ 3.0 V				V _{CC} ≥ 2.7 V				Unit	Condition
		μPD43256B-A10		μPD43256B-A12		μPD43256B-B10		μPD43256B-B12			
		MIN.	MAX.	MIN.	MAX.	MIN.	MAX.	MIN.	MAX.		
Write cycle time	t _{wc}	100		120		100		120		ns	
$\overline{\text{CS}}$ to end of write	t _{cw}	90		110		90		110		ns	
Address valid to end of write	t _{aw}	90		110		90		110		ns	
Write pulse width	t _{wp}	80		100		80		100		ns	
Data valid to end of write	t _{dw}	60		70		60		70		ns	
Data hold time	t _{dh}	0		0		0		0		ns	
Address setup time	t _{as}	0		0		0		0		ns	
Write recovery time	t _{wr}	5		5		5		5		ns	
$\overline{\text{WE}}$ to output in high impedance	t _{whz}		35		40		35		40	ns	Note
Output active from end of write	t _{ow}	10		10		10		10		ns	

Note See the output load shown in Fig. 2.

Write Cycle Timing Chart 1 (\overline{WE} Controlled)

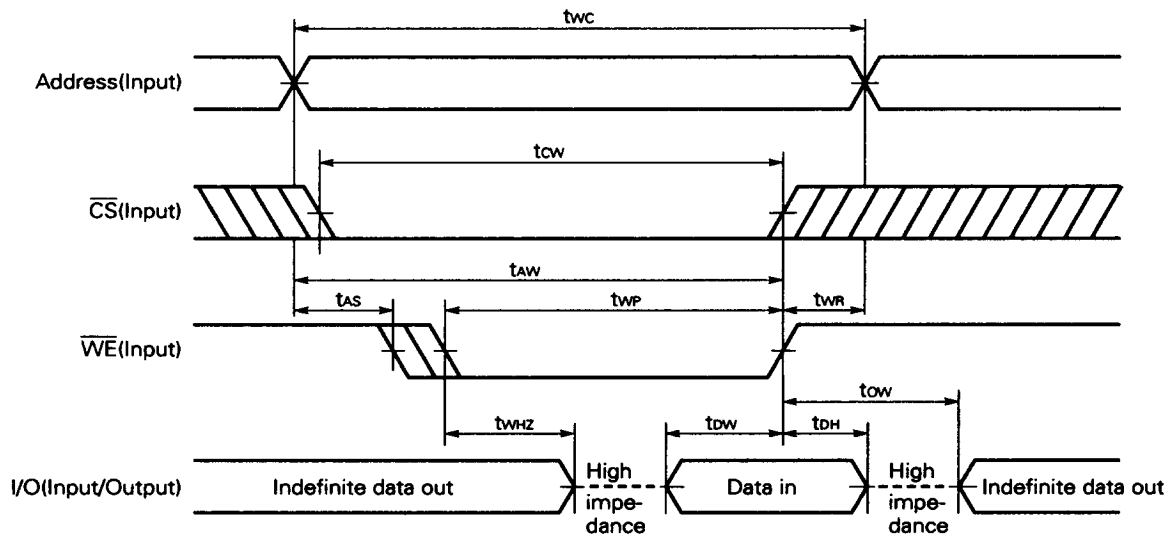

Caution \overline{CS} or \overline{WE} should be fixed to high level during address transition.

- Remark**
1. Write operation is done during the overlap time of a low level \overline{CS} and a low level \overline{WE} .
 2. When \overline{WE} is at low level, the I/O pins are always high impedance. When \overline{WE} is at high level, read operation is executed. Therefore \overline{OE} should be at high level to make the I/O pins high impedance.
 3. If \overline{CS} changes to low level at the same time or after the change of \overline{WE} to low level, the I/O pins will remain high impedance state.

Write Cycle Timing Chart 2 (\overline{CS} Controlled)

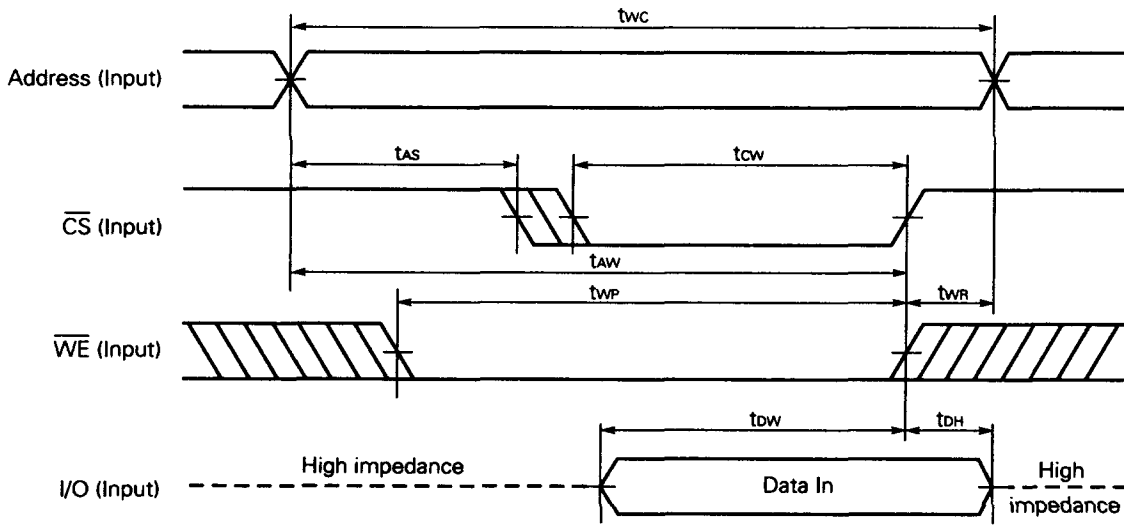

Caution \overline{CS} or \overline{WE} should be fixed to high level during address transition.

Remark Write operation is done during the overlap time of a low level \overline{CS} and a low level \overline{WE} .

Low Vcc Data Retention Characteristics

L Version (μPD43256B-L: T_A = 0 to 70 °C)

Parameter	Symbol	Test conditions	MIN.	TYP.	MAX.	Unit
Data retention supply voltage	V _{CCDR}	$\overline{CS} \geq V_{CC} - 0.2 V$	2.0		5.5	V
Data retention supply current	I _{CCDR}	V _{CC} = 3.0 V, $\overline{CS} \geq V_{CC} - 0.2 V$		1	50 ^{Note}	μA
Chip deselection to data retention mode	t _{CDR}		0			ns
Operation recovery time	t _R		5			ms

Note 15 μA (T_A ≤ 40 °C)

LL Version (μPD43256B-LL: T_A = 0 to 70 °C)

A Version (μPD43256B-A: T_A = 0 to 70 °C)

B Version (μPD43256B-B: T_A = 0 to 70 °C)

Parameter	Symbol	Test conditions	MIN.	TYP.	MAX.	Unit
Data retention supply voltage	V _{CCDR}	$\overline{CS} \geq V_{CC} - 0.2 V$	2.0		5.5	V
Data retention supply current	I _{CCDR}	V _{CC} = 3.0 V, $\overline{CS} \geq V_{CC} - 0.2 V$		0.5	20 ^{Note}	μA
Chip deselection to data retention mode	t _{CDR}		0			ns
Operation recovery time	t _R		5			ms

Note 3 μA (T_A ≤ 40 °C), 1 μA (T_A ≤ 25 °C)

Data Retention Timing Chart

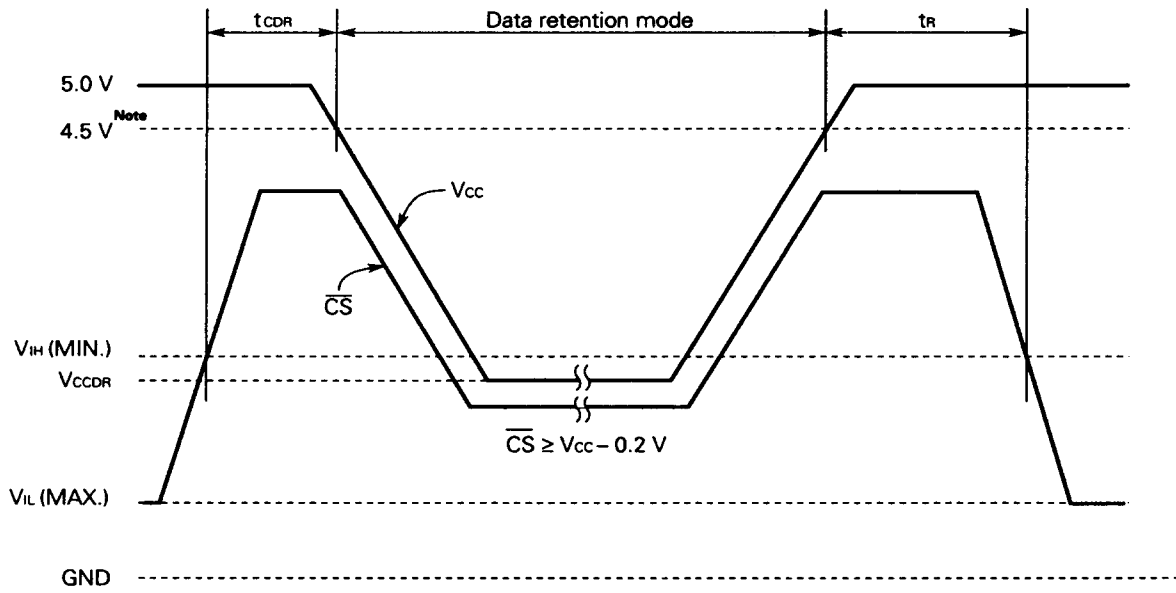

Note A Version: 3.0 V, B Version: 2.7 V

Remark The other pins (address, \overline{OE} , \overline{WE} , I/Os) can be in high impedance state.

Package Drawings

28 PIN PLASTIC DIP (600 mil)

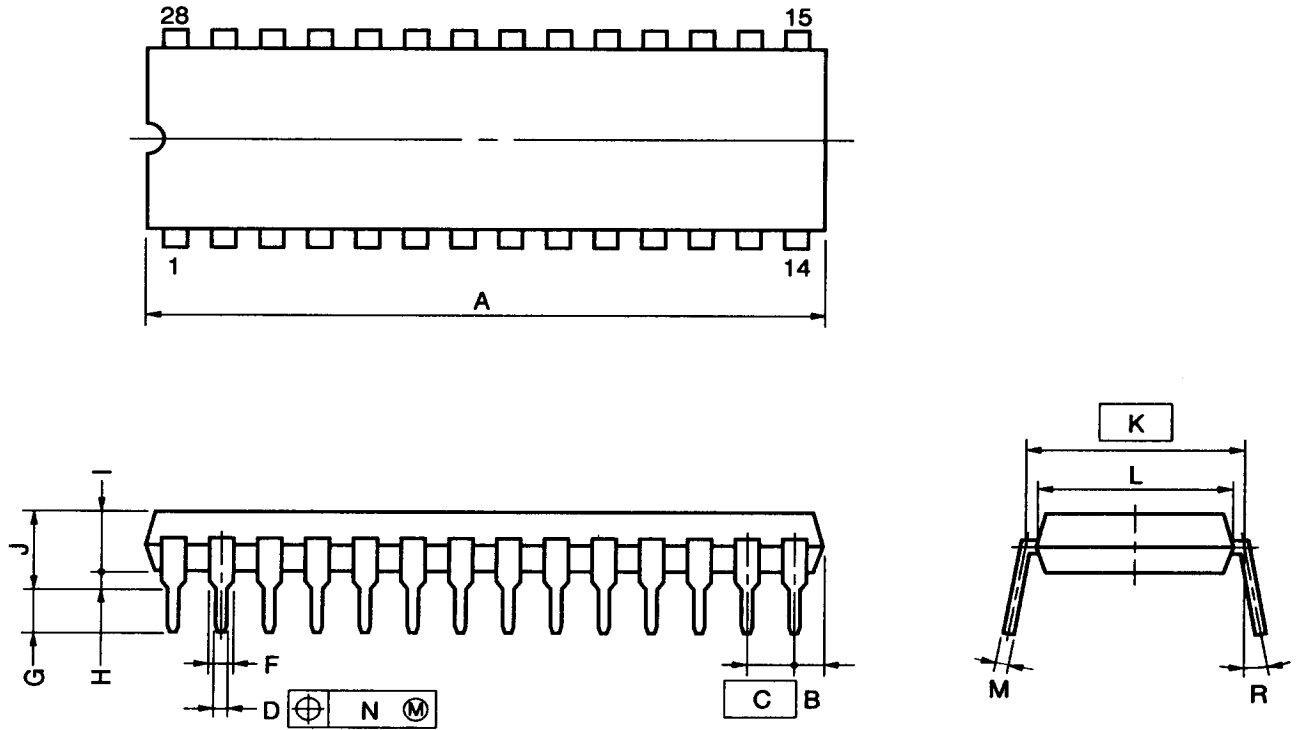

NOTES

- 1) Each lead centerline is located within 0.25 mm (0.01 inch) of its true position (T.P.) at maximum material condition.
- 2) Item "K" to center of leads when formed parallel.

ITEM	MILLIMETERS	INCHES
A	38.10 MAX.	1.500 MAX.
B	2.54 MAX.	0.100 MAX.
C	2.54 (T.P.)	0.100 (T.P.)
D	0.50±0.10	0.020 ^{+0.004} _{-0.005}
F	1.2 MIN.	0.047 MIN.
G	3.6±0.3	0.142±0.012
H	0.51 MIN.	0.020 MIN.
I	4.31 MAX.	0.170 MAX.
J	5.72 MAX.	0.226 MAX.
K	15.24 (T.P.)	0.600 (T.P.)
L	13.2	0.520
M	0.25 ^{+0.10} _{-0.05}	0.010 ^{+0.004} _{-0.003}
N	0.25	0.01
R	0 ~ 15°	0 ~ 15°

P28C-100-600A1-1

28 PIN PLASTIC SOP(450mil)

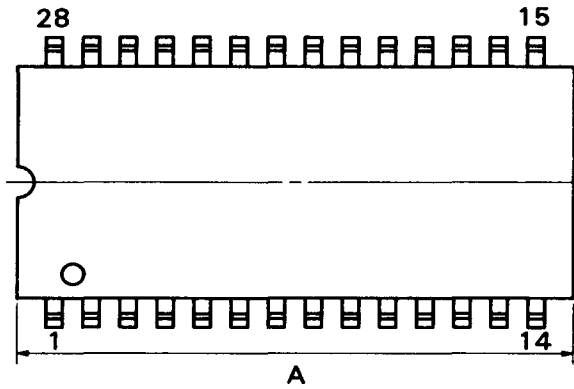

detail of lead end

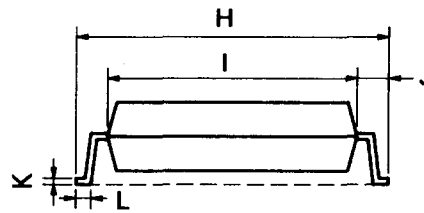
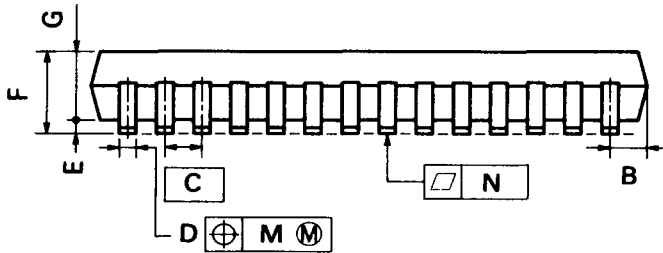
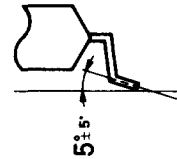

P28GU-50-450A

NOTE

Each lead centerline is located within 0.12 mm (0.005 inch) of its true position (T.P.) at maximum material condition.

ITEM	MILLIMETERS	INCHES
A	19.05MAX.	0.750MAX.
B	1.27MAX.	0.050MAX.
C	1.27 (T.P.)	0.050 (T.P.)
D	0.40±0.10	0.016 ^{+0.004} _{-0.004}
E	0.2±0.1	0.008±0.004
F	3.0MAX.	0.119MAX.
G	2.55±0.1	0.100 ^{+0.005} _{-0.005}
H	11.8±0.3	0.465 ^{+0.013} _{-0.013}
I	8.4±0.1	0.331 ^{+0.004} _{-0.004}
J	1.7±0.2	0.067±0.008
K	0.20±0.03	0.008 ^{+0.003} _{-0.003}
L	0.7±0.2	0.028 ^{+0.008} _{-0.008}
M	0.12	0.005
N	0.10	0.004

32 PIN PLASTIC TSOP(I) (600 mil)

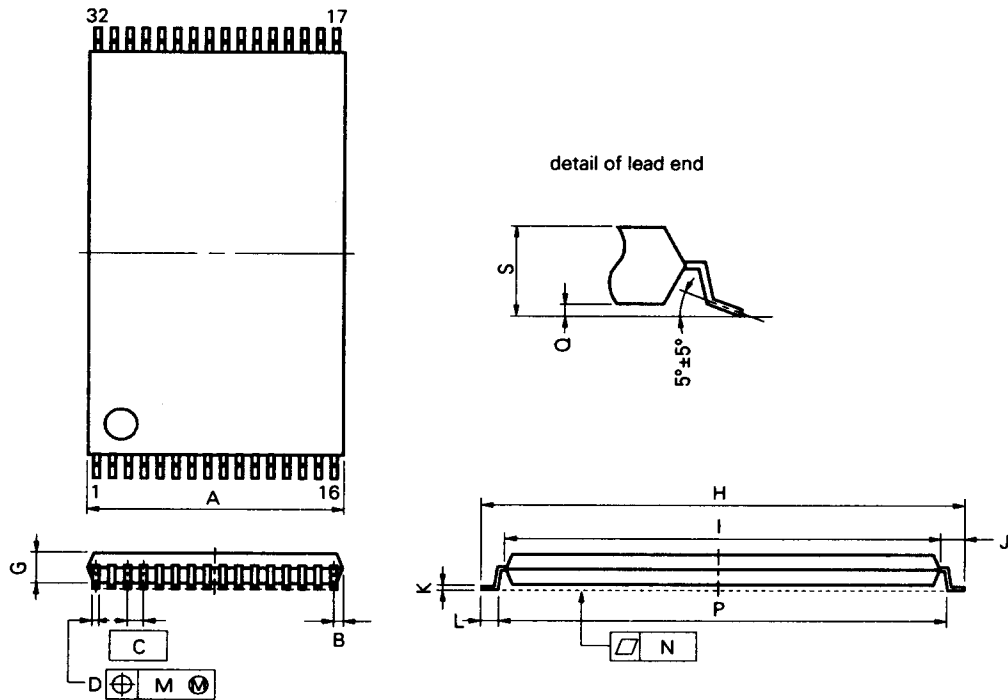

NOTE

Each lead centerline is located within 0.08 mm (0.003 inch) of its true position (T.P.) at maximum material condition.

S32GX-50-EJA-1

ITEM	MILLIMETERS	INCHES
A	8.2 MAX.	0.323 MAX.
B	0.45 MAX.	0.018 MAX.
C	0.5 (T.P.)	0.020 (T.P.)
D	0.20±0.10	0.008±0.004
G	1.05	0.041
H	15.3±0.2	0.602 ^{+0.009} _{-0.008}
I	13.7	0.539
J	0.8±0.2	0.031 ^{+0.009} _{-0.008}
K	0.125 ^{+0.10} _{-0.05}	0.005 ^{+0.004} _{-0.002}
L	0.5±0.1	0.020 ^{+0.004} _{-0.005}
M	0.08	0.003
N	0.10	0.004
P	14.3±0.2	0.563±0.008
Q	0.05±0.05	0.002±0.002
S	1.27 MAX.	0.050 MAX.

32 PIN PLASTIC TSOP(I) (600 mil)

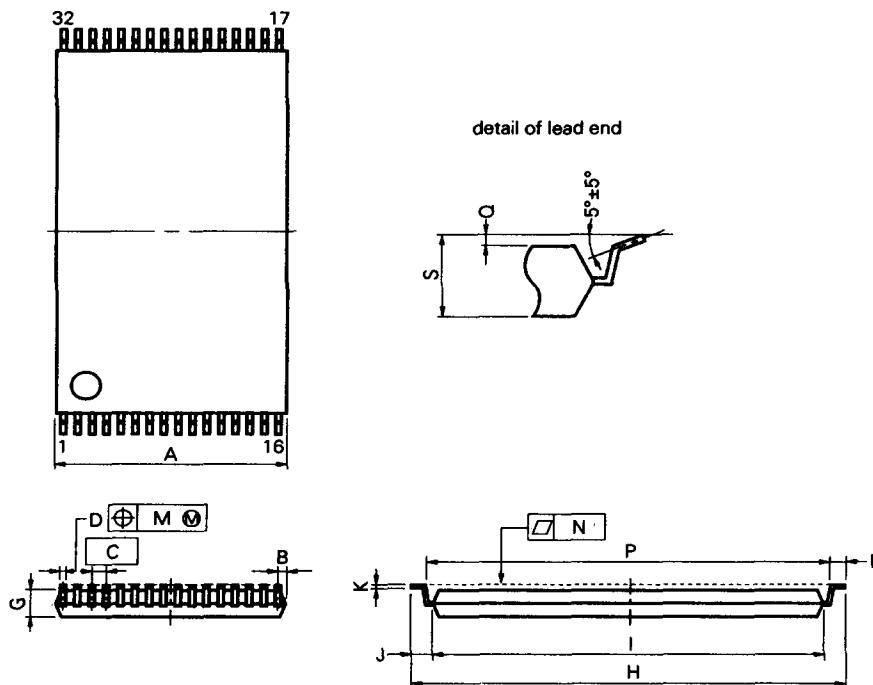

NOTE

Each lead centerline is located within 0.08 mm (0.003 inch) of its true position (T.P.) at maximum material condition.

S32GX-50-EKA-1

ITEM	MILLIMETERS	INCHES
A	8.2 MAX.	0.323 MAX.
B	0.45 MAX.	0.018 MAX.
C	0.5 (T.P.)	0.020 (T.P.)
D	0.20±0.10	0.008±0.004
G	1.05	0.041
H	15.3±0.2	0.602 ^{+0.009} _{-0.008}
I	13.7	0.539
J	0.8±0.2	0.031 ^{+0.009} _{-0.008}
K	0.125 ^{+0.10} _{-0.05}	0.005 ^{+0.004} _{-0.002}
L	0.5±0.1	0.020 ^{+0.004} _{-0.005}
M	0.08	0.003
N	0.10	0.004
P	14.3±0.2	0.563±0.008
Q	0.05±0.05	0.002±0.002
S	1.27 MAX.	0.050 MAX.

Recommended Soldering Conditions

The following conditions (See tables below and next page) must be met when soldering μPD43256B. For more details, refer to our document "SEMICONDUCTOR DEVICE MOUNTING TECHNOLOGY MANUAL" (IEI-1207).

Please consult with our sales offices in case other soldering process is used, or in case soldering is done under different conditions.

Types of Surface Mount Device

μPD43256BGU: 28-pin plastic SOP (450 mil)

Soldering process	Soldering conditions	Symbol
Infrared ray reflow	Peak package's surface temperature: 230 °C or below, Reflow time: 30 seconds or below (210 °C or higher), Number or reflow processes: 1 Exposure limit ^{Note} : 7 days (10 hours pre-baking is required at 125 °C afterwards)	IR30-107-1
VPS	Peak package's temperature: 215 °C or below, Reflow time: 40 seconds or below (200 °C or higher), Number of reflow processes: 1 Exposure limit ^{Note} : 7 days (10 hours pre-baking is required at 125 °C afterwards)	VP15-107-1
Wave soldering	Solder temperature: 260 °C or below, Flow time: 10 seconds or below, Temperature of pre-heat: 120 °C or below (Plastic surface temperature) Number of reflow processes: 1 Exposure limit ^{Note} : 7 days (10 hours pre-baking is required at 125 °C afterwards)	WS60-107-1
Partial heating method	Terminal temperature: 300 °C or below, Time: 3 seconds or below (Per side of leads)	—

Note Exposure limit before soldering after dry-pack package is opened.
Storage conditions: 25 °C and relative humidity at 65 % or less.

Caution Do not apply more than one soldering method at any one time, except for "Partial heating method."

μPD43256BGX-EJA: 32-pin plastic TSOP (I) (600 mil) (Normal bent)

μPD43256BGX-EKA: 32-pin plastic TSOP (I) (600 mil) (Reverse bent)

Soldering process	Soldering conditions	Symbol
Infrared ray reflow	Peak package's surface temperature: 235 °C or below, Reflow time: 30 seconds or below (210 °C or higher), Number or reflow processes: 1 Exposure limit ^{Note} : 8 hours (10 hours pre-baking is required at 125 °C afterwards)	IR35-10B-1
VPS	Peak package's temperature: 215 °C or below, Reflow time: 40 seconds or below (200 °C or higher), Number of reflow processes: 1 Exposure limit ^{Note} : 8 hours (10 hours pre-baking is required at 125 °C afterwards)	VP15-10B-1
Partial heating method	Terminal temperature: 300 °C or below, Time: 3 seconds or below (Per side of leads)	—

Note Exposure limit before soldering after dry-pack package is opened.
Storage conditions: 25 °C and relative humidity at 65 % or less.

Caution Do not apply more than one soldering method at any one time, except for "Partial heating method."

Type of Through Hole Mount Device**μPD43256BCZ: 28-pin plastic DIP (600 mil)**

Soldering process	Soldering conditions
Wave soldering (only to leads)	Solder temperature: 260 °C or below, Flow time: 10 seconds or below
Partial heating method	Terminal temperature: 300 °C or below, Time: 3 seconds or below (Per one lead)

Caution Do not jet molten solder on the surface of package.

Information

μPD43256B New Line Up

(1) Package : 28-pin plastic TSOP (I) (0.55pitch, 8 × 13.4 mm) (Normal, Reverse bent)

(2) Part Number : μPD43256BGW-70L/85L
 μPD43256BGW-70LL/85LL
 μPD43256BGW-A10/A12
 μPD43256BGW-B12

(3) Release : Ex-factory 1995. October

(4) Pin Configuration (Marking Side)

28-pin plastic TSOP (I) (Normal bent)

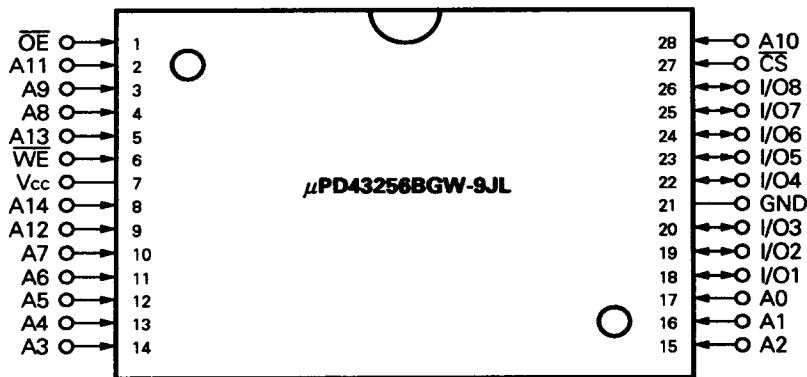

- A0 to A14 : Address Input
- I/O1 to I/O8 : Data Input / Output
- \overline{CS} : Chip Select Input
- \overline{WE} : Write Enable Input
- \overline{OE} : Output Enable Input
- Vcc : Power Supply
- GND : Ground

28-pin plastic TSOP (I) (Reverse bent)

