



STMPE811

S-Touch™ advanced resistive touchscreen controller with 8-bit GPIO expander

Features

- 8 GPIOs
- 1.8 - 3.3 V operating voltage
- Integrated 4-wire touchscreen controller
- Interrupt output pin
- Wakeup feature on each I/O
- SPI and I²C interface
- Up to 2 devices sharing the same bus in I²C mode (1 address line)
- 8-input 12-bit ADC
- 128-depth buffer touchscreen controller
- Touchscreen movement detection algorithm
- 25 kV air-gap ESD protection (system level)
- 4 kV HBM ESD protection (device level)

Applications

- Portable media players
- Game consoles
- Mobile and smartphones
- GPS

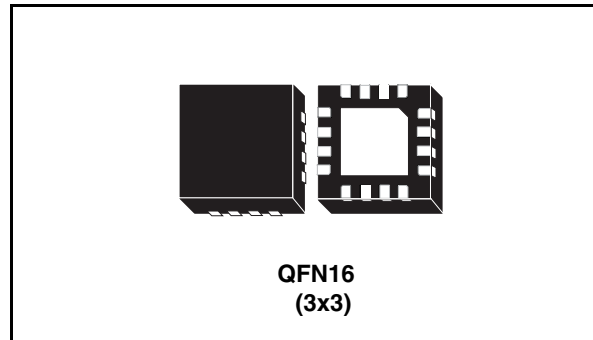

Description

The STMPE811 is a GPIO (general purpose input/output) port expander able to interface a main digital ASIC via the two-line bidirectional bus (I²C). A separate GPIO expander is often used in mobile multimedia platforms to solve the problems of the limited amount of GPIOs typically available on the digital engine.

The STMPE811 offers great flexibility, as each I/O can be configured as input, output or specific functions. The device has been designed with very low quiescent current and includes a wakeup feature for each I/O, to optimize the power consumption of the device.

A 4-wire touchscreen controller is built into the STMPE811. The touchscreen controller is enhanced with a movement tracking algorithm (to avoid excessive data), a 128 x 32 bit buffer and programmable active window feature.

Table 1. Device summary

Order code	Package	Packaging
STMPE811QTR	QFN16	Tape and reel

Contents

1	STMPE811 functional overview	6
2	Pin configuration and functions	7
	2.1 Pin functions	8
3	I2C and SPI interface	9
	3.1 Interface selection	9
4	I2C interface	10
	4.1 I2C features	12
	4.2 Data input	13
	4.3 Read operation	14
	4.4 Write operations	14
5	SPI interface	15
	5.1 SPI protocol definition	15
	5.1.1 Register reading	15
	5.1.2 Register write	16
	5.1.3 Termination of data transfer	16
	5.2 SPI timing modes	17
	5.2.1 SPI timing definition	17
6	STMPE811 registers	19
7	System and identification registers	22
8	Interrupt system	25
9	Analog-to-digital converter	29
10	Touchscreen controller	33
	10.1 Driver and switch control unit	33
11	Touchscreen controller programming sequence	46

12	Temperature sensor	48
13	GPIO controller	50
	13.0.1 Power supply	52
	13.0.2 Power-up reset (POR)	53
14	Maximum rating	54
	14.1 Recommended operating conditions	55
15	Electrical specifications	56
16	Package mechanical data	58
17	Revision history	64

List of tables

Table 1.	Device summary	1
Table 2.	Pin assignments	7
Table 3.	Pin configuration for IN2, IN3	8
Table 4.	Pin configuration for X+, Y+, X-, Y-.	8
Table 5.	Interface selection pins	9
Table 6.	I2C address	10
Table 7.	I2C timing	11
Table 8.	Operating modes	13
Table 9.	SPI timing modes	17
Table 10.	SPI timing specification.	17
Table 11.	Register summary map table	19
Table 12.	System and identification registers map	22
Table 13.	ADC controller register summary table	29
Table 14.	ADC conversion time	32
Table 15.	Touchscreen controller register summary table	35
Table 16.	Touchscreen controller DATA register	43
Table 17.	Touchscreen parameters	48
Table 18.	GPIO control registers	50
Table 19.	Absolute maximum ratings	54
Table 20.	Power consumption	55
Table 21.	DC electrical characteristics (-40 °C to 85 °C) all GPIOs comply to JEDEC standard JESD-8-7)	56
Table 22.	AC electrical characteristics (-40 °C to 85 °C)	56
Table 23.	ADC specification (-40 °C to 85 °C)	57
Table 24.	Switch drivers specification.	57
Table 25.	Voltage reference specification.	57
Table 26.	Package mechanical data for QFN16 (3 x 3 x 1 mm) - 0.50 pitch	60
Table 27.	Exposed pad variation	60
Table 28.	Footprint dimensions	61
Table 29.	Document revision history	64

List of figures

Figure 1.	STMPE811 functional block diagram	6
Figure 2.	STMPE811 pin configuration (top through view)	7
Figure 3.	STMPE811 interface.	9
Figure 4.	STMPE811 I2C interface	10
Figure 5.	I ² C timing diagram	10
Figure 6.	Read and write modes (random and sequential)	13
Figure 7.	SPI timing specification.	18
Figure 8.	Interrupt system diagram	25
Figure 9.	Touchscreen controller block diagram	33
Figure 10.	Window tracking	34
Figure 11.	Sampling.	34
Figure 12.	Package outline for QFN16 (3 x 3 x 1 mm) - 0.50 pitch	59
Figure 13.	Recommended footprint	61
Figure 14.	Carrier tape for QFN16 (3 x 3 x 1 mm) - 0.50 pitch	62
Figure 15.	Reel information for QFN16 (3 x 3 x 1 mm) - 0.50 pitch	63

1 STMPE811 functional overview

The STMP811 consists of the following blocks:

- I²C and SPI interface
- Analog-to-digital converter (ADC)
- Touchscreen controller (TSC)
- Driver and switch control unit
- Temperature sensor
- GPIO controller

Figure 1. STMPE811 functional block diagram

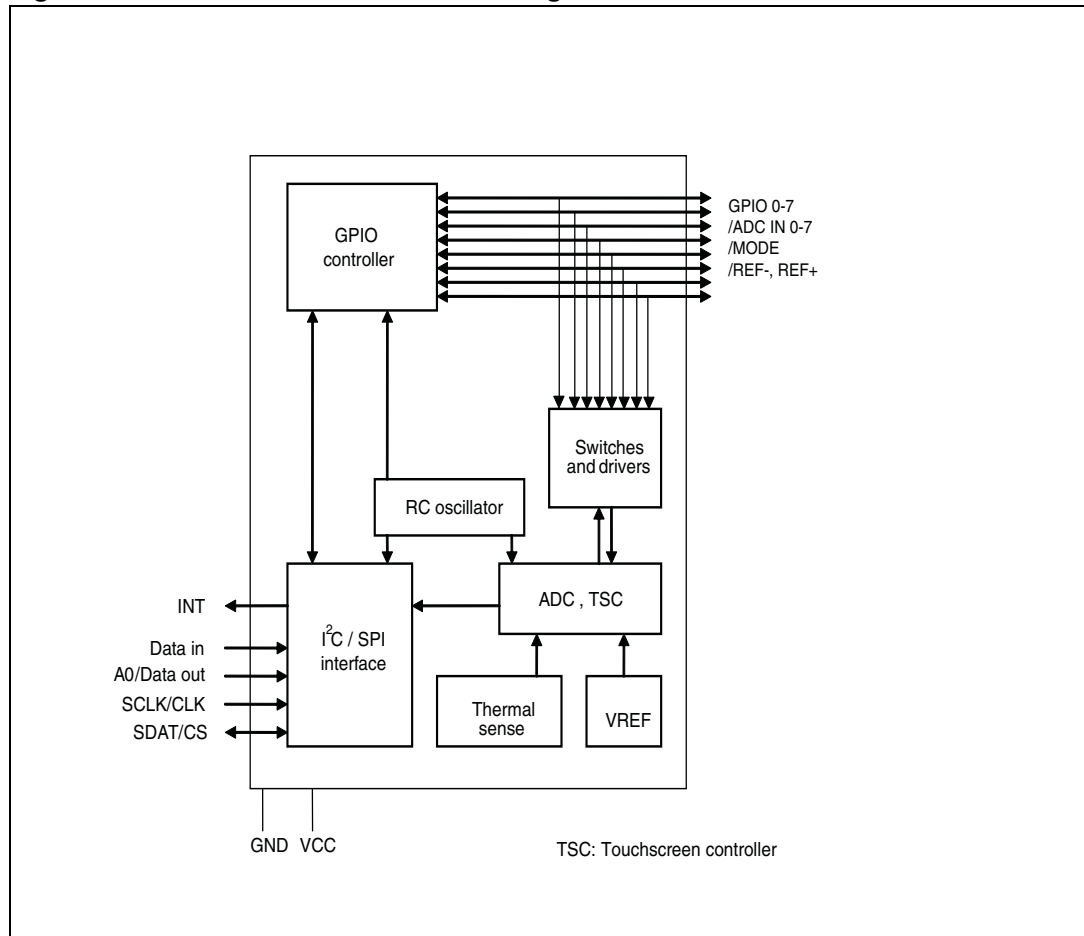

2 Pin configuration and functions

Figure 2. STMPE811 pin configuration (top through view)

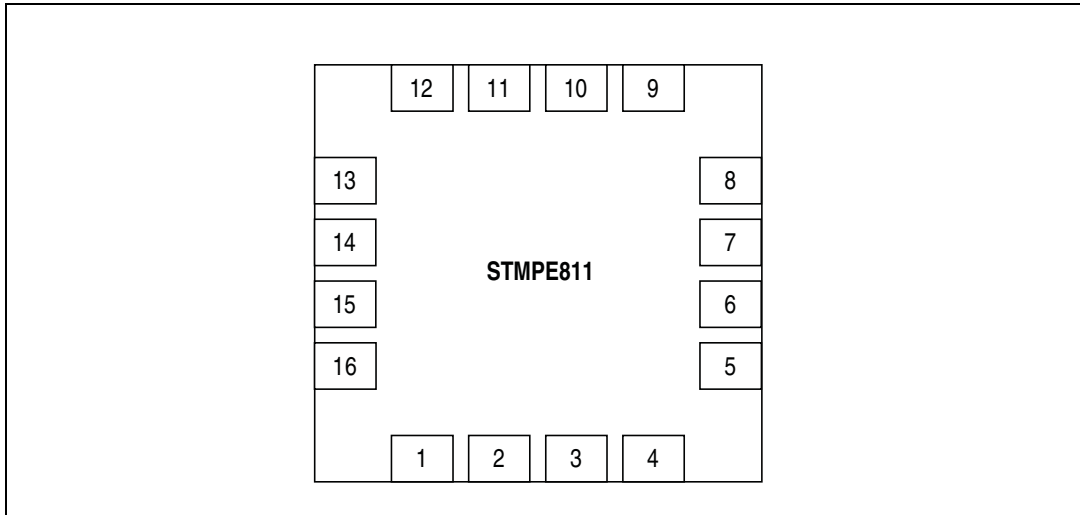

Table 2. Pin assignments

Pin	Name	Function
1	Y-	Y-/GPIO-7
2	INT	Interrupt output (V_{CC} domain), open drain
3	A0/Data Out	I ² C address in Reset, Data out in SPI mode (V_{CC} domain)
4	SCLK	I ² C/SPI clock (V_{CC} domain)
5	SDAT	I ² C data/SPI CS (V_{CC} domain)
6	V_{CC}	1.8 –3.3 V supply voltage
7	Data in	SPI Data In (V_{CC} domain)
8	IN0	IN0/GPIO-0
9	IN1	IN1/GPIO-1/MODE In RESET state, MODE selects the type of serial interface "0" - I ² C "1" - SPI
10	GND	Ground
11	IN2	IN2/GPIO-2
12	IN3	IN3/GPIO-3
13	X+	X+/GPIO-4
14	Vio	Supply for touchscreen driver and GPIO
15	Y+	Y+/GPIO-5
16	X-	X-/GPIO-6

2.1 Pin functions

The STMPE811 is designed to provide maximum features and flexibility in a very small pin-count package. Most of the pins are multi-functional. [Table 3](#) and [Table 4](#) show how to select the pin's function.

Table 3. Pin configuration for IN2, IN3

Pin / control register	GPIO_AF = 1	GPIO_AF = 0	
	ADC control 1 bit 1 = don't care	ADC control 1 bit 1 = 0	ADC control 1 bit 1 = 1
IN0	GPIO-0	ADC	
IN1	GPIO-1	ADC	
IN2	GPIO-2	ADC	External reference +
IN3	GPIO-3	ADC	External reference -

Table 4. Pin configuration for X+, Y+, X-, Y-

Pin / control register	GPIO_AF = 1	GPIO_AF = 0	
	TSC control 1 bit 0 = don't care	TSC control 1 bit 0 = 0	TSC control 1 bit 0 = 1
X+	GPIO-4	ADC	TSC X+
Y+	GPIO-5	ADC	TSC Y+
X-	GPIO-6	ADC	TSC X-
Y-	GPIO-7	ADC	TSC Y-

3 I²C and SPI interface

3.1 Interface selection

The STMPE811 interfaces with the host CPU via a I²C or SPI interface. The pin IN_1 allows the selection of interface protocol at reset state.

Figure 3. STMPE811 interface

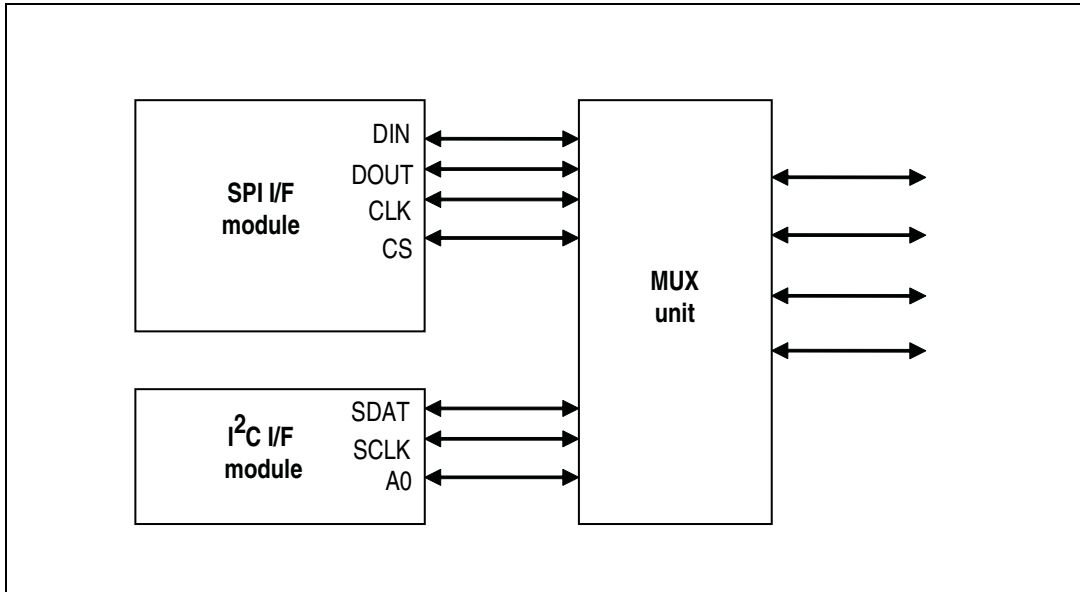

Table 5. Interface selection pins

Pin	I ² C function	SPI function	Reset state
3	Address 0	Data out	CPHA for SPI
4	CLOCK	CLOCK	—
5	SDATA	CS	CPOL_N for SPI
7	—	Data in	—
9	MODE	I ² C set to '0'	Set to '1' for SPI

4 I²C interface

The addressing scheme of STMPE811 is designed to allow up to 2 devices to be connected to the same I²C bus.

Figure 4. STMPE811 I²C interface

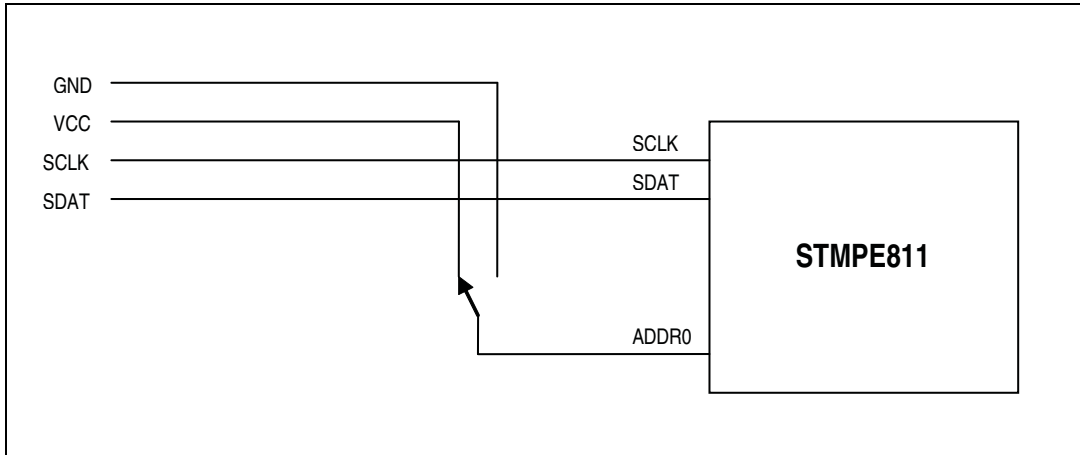

Table 6. I²C address

ADDR0	Address
0	0 x 82
1	0 x 88

For the bus master to communicate to the slave device, the bus master must initiate a Start condition and be followed by the slave device address. Accompanying the slave device address, is a read/write bit (R/W). The bit is set to 1 for read and 0 for write operation. If a match occurs on the slave device address, the corresponding device gives an acknowledge on the SDA during the 9th bit time. If there is no match, it deselects itself from the bus by not responding to the transaction.

Figure 5. I²C timing diagram

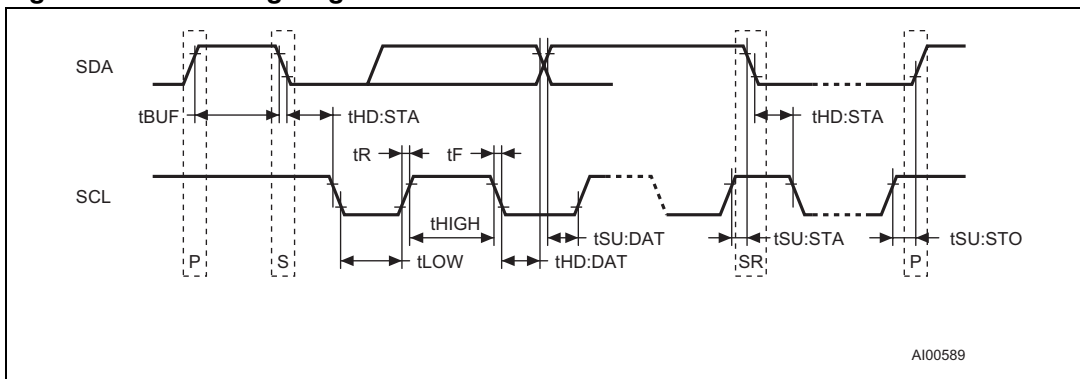

Table 7. I²C timing

Symbol	Parameter	Min	Typ	Max	Uni
f_{SCL}	SCL clock frequency	0	—	400	kHz
t_{LOW}	Clock low period	1.3	—	—	μ s
t_{HIGH}	Clock high period	600	—	—	ns
t_F	SDA and SCL fall time		—	300	ns
$t_{HD:STA}$	START condition hold time (after this period the first clock is generated)	600	—	—	ns
$t_{SU:STA}$	START condition setup time (only relevant for a repeated start period)	600	—	—	ns
$t_{SU:DAT}$	Data setup time	100	—	—	ns
$t_{HD:DAT}$	Data hold time	0	—	—	μ s
$t_{SU:STO}$	STOP condition setup time	600	—	—	ns
t_{BUF}	Time the bus must be free before a new transmission can start	1.3	—	—	μ s

4.1 I²C features

The features that are supported by the I²C interface are listed below:

- I²C slave device
- Operates at 1.8 V
- Compliant to Philips I²C specification version 2.1
- Supports standard (up to 100 Kbps) and fast (up to 400 Kbps) modes

Start condition

A Start condition is identified by a falling edge of SDATA while SCLK is stable at high state. A Start condition must precede any data/command transfer. The device continuously monitors for a Start condition and does not respond to any transaction unless one is encountered.

Stop condition

A Stop condition is identified by a rising edge of SDATA while SCLK is stable at high state. A Stop condition terminates communication between the slave device and the bus master. A read command that is followed by NoAck can be followed by a Stop condition to force the slave device into idle mode. When the slave device is in idle mode, it is ready to receive the next I²C transaction. A Stop condition at the end of a write command stops the write operation to registers.

Acknowledge bit

The acknowledge bit is used to indicate a successful byte transfer. The bus transmitter releases the SDATA after sending eight bits of data. During the ninth bit, the receiver pulls the SDATA low to acknowledge the receipt of the eight bits of data. The receiver may leave the SDATA in high state if it does not acknowledge the receipt of the data.

4.2 Data input

The device samples the data input on SDATA on the rising edge of the SCLK. The SDATA signal must be stable during the rising edge of SCLK and the SDATA signal must change only when SCLK is driven low.

Table 8. Operating modes

Mode	Byte	Programming sequence
Read	≥1	Start, Device address, $\overline{R/\overline{W}} = 0$, Register address to be read
		Restart, Device address, $\overline{R/\overline{W}} = 1$, Data Read, Stop
		If no Stop is issued, the Data Read can be continuously performed. If the register address falls within the range that allows an address auto-increment, then the register address auto-increments internally after every byte of data being read.
Write	≥1	Start, Device address, $\overline{R/\overline{W}} = 0$, Register address to be written, Data Write, Stop
		If no Stop is issued, the Data Write can be continuously performed. If the register address falls within the range that allows address auto-increment, then the register address auto-increments internally after every byte of data being written in. For those register addresses that fall within a non-incremental address range, the address is kept static throughout the entire write operation. Refer to the memory map table for the address ranges that are auto and non-increment.

Figure 6. Read and write modes (random and sequential)

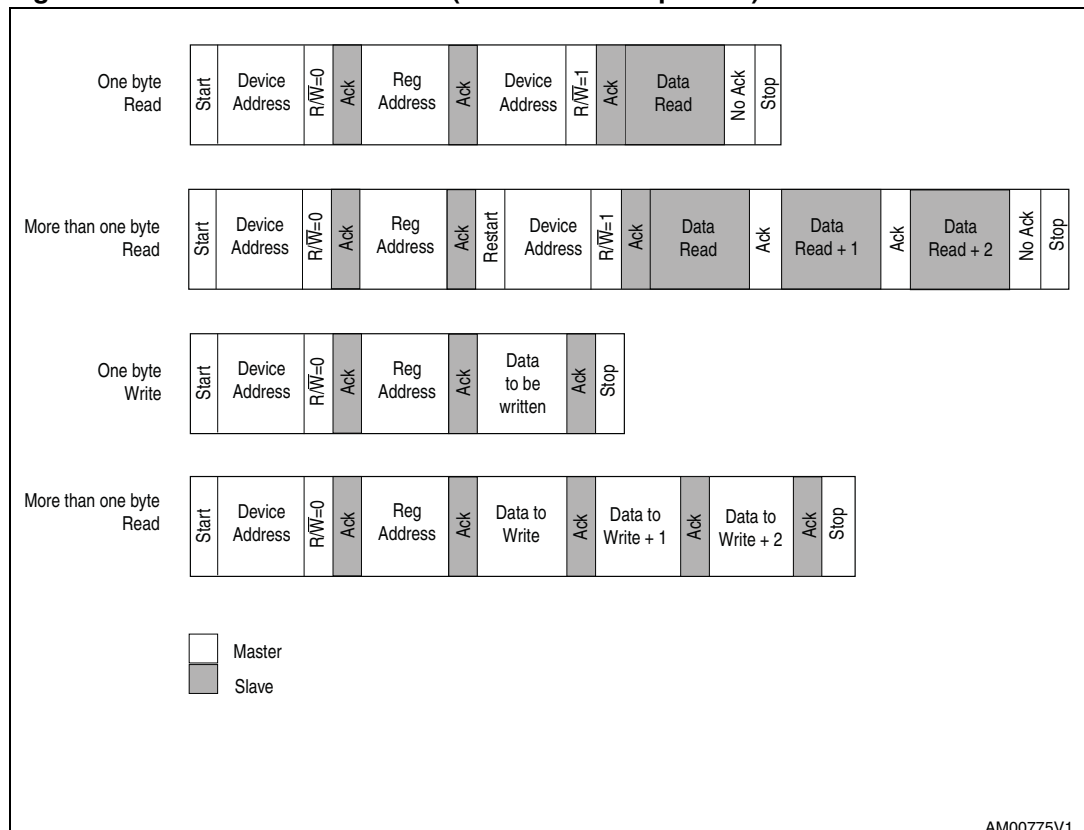

4.3 Read operation

A write is first performed to load the register address into the Address Counter but without sending a Stop condition. Then, the bus master sends a reStart condition and repeats the Device Address with the R/W bit set to 1. The slave device acknowledges and outputs the content of the addressed byte. If no additional data is to be read, the bus master must not acknowledge the byte and terminates the transfer with a Stop condition.

If the bus master acknowledges the data byte, then it can continue to perform the data reading. To terminate the stream of data bytes, the bus master must not acknowledge the last output byte, and be followed by a Stop condition. If the address of the register written into the Address Counter falls within the range of addresses that has the auto-increment function, the data being read are coming from consecutive addresses, which the internal Address Counter automatically increments after each byte output. After the last memory address, the Address Counter 'rolls-over' and the device continues to output data from the memory address of 0x00. Similarly, for the register address that falls within a non-increment range of addresses, the output data byte comes from the same address (which is the address referred by the Address Counter).

Acknowledgement in read operation

For the above read command, the slave device waits, after each byte read, for an acknowledgement during the ninth bit time. If the bus master does not drive the SDA to a low state, then the slave device terminates and switches back to its idle mode, waiting for the next command.

4.4 Write operations

A write is first performed to load the register address into the Address Counter without sending a Stop condition. After the bus master receives an acknowledgement from the slave device, it may start to send a data byte to the register (referred by the Address Counter). The slave device again acknowledges and the bus master terminates the transfer with a Stop condition.

If the bus master needs to write more data, it can continue the write operation without issuing the Stop condition. Whether the Address Counter autoincrements or not after each data byte write depends on the address of the register written into the Address Counter. After the bus master writes the last data byte and the slave device acknowledges the receipt of the last data, the bus master may terminate the write operation by sending a Stop condition. When the Address Counter reaches the last memory address, it 'rolls-over' to the next data byte write.

5 SPI interface

The SPI (serial peripheral interface) in STMPE811 uses a 4-wire communication connection (DATA IN, DATA OUT, CLK, CS). In the diagram, “Data in” is referred to as MOSI (master out slave in) and “DATA out” is referred to as MISO (master in slave out).

5.1 SPI protocol definition

The SPI follows a byte-sized transfer protocol. All transfers begin with an assertion of CS_n signal (falling edge). The protocol for reading and writing is different and the selection between a read and a write cycle is dependent on the first captured bit on the slave device. A '1' denotes a read operation and a '0' denotes a write operation. The SPI protocol defined in this section is shown in [Figure 3](#).

The following are the main features supported by this SPI implementation.

- Support of 1 MHz maximum clock frequency.
- Support for autoincrement of address for both read and write.
- Full duplex support for read operation.
- Daisy chain configuration support for write operation.
- Robust implementation that can filter glitches of up to 50 ns on the CS_n and SCL pins.
- Support for all 4 modes of SPI as defined by the CPHA, CPOL bits on SPICON.

5.1.1 Register reading

The following steps need to be followed for the register read through the SPI.

1. Assert CS_n by driving a '0' on this pin.
2. Drive a '1' on the first SCL launch clock on MOSI to select a read operation.
3. The next 7 bits on MOSI denote the 7-bit register address (MSB first).
4. The next address byte can now be transmitted on the MOSI. If the autoincrement bit is set, the following address transmitted on the MOSI is ignored. Internally, the address is incremented. If the autoincrement bit is not set, then the following byte denotes the address of the register to be read next.
5. Read data is transmitted by the slave device on the MISO (MSB first), starting from the launch clock following the last address bit on the MOSI.
6. Full duplex read operation is achieved by transmitting the next address on MOSI while the data from the previous address is available on MISO.
7. To end the read operation, a dummy address of all 0's is sent on MOSI.

5.1.2 Register write

The following steps need to be followed for register write through SPI.

1. Assert CS_n by driving a '0' on this pin.
2. Drive a '0' on the first SCL launch clock on MOSI to select a write operation.
3. The next 7 bits on MOSI denote the 7-bit register address (MSB first).
4. The next byte on the MOSI denotes data to be written.
5. The following transmissions on MOSI are considered byte-sized data. The register address to which the following data is written depends on whether the autoincrement bit in the SPICON register is set. If this bit has been set previously, the register address is incremented for data writes.

5.1.3 Termination of data transfer

A transfer can be terminated before the last launch edge by deasserting the CS_n signal. If the last launch clock is detected, it is assumed that the data transfer is successful.

5.2 SPI timing modes

The SPI timing modes are defined by CPHA and CPOL, CPHA and CPOL are read from the "SDAT" and "AO" pins during power-up reset. The following four modes are defined according to this setting.

Table 9. SPI timing modes

CPOL_N (SDAT pin)	CPOL	CPHA (ADDR pin)	Mode
1	0	0	0
1	0	1	1
0	1	0	2
0	1	1	3

The clocking diagrams of these modes are shown in ON reset. The device always operates in mode 0. Once the bits are set in the SPICON register, the mode change takes effect on the next transaction defined by the CS_n pin being deasserted and asserted.

5.2.1 SPI timing definition

Table 10. SPI timing specification

Symbol	Description	Timing			Unit
		Min	Typ	Max	
t _{css}	CS_n falling to first capture clock	1	—	—	μs
t _{CL}	Clock low period	500	—	—	ns
t _{CH}	Clock high period	500	—	—	ns
t _{LDI}	Launch clock to MOSI data valid	—	—	20	ns
t _{LDO}	Launch clock to MISO data valid	—	—	330	μs
t _{DI}	Data on MOSI valid	1	—	—	μs
t _{CCS}	Last clock edge to CS_n high	1	—	—	μs
t _{CSH}	CS_n high period	2	—	—	μs

Table 10. SPI timing specification (continued)

Symbol	Description	Timing			Unit
		Min	Typ	Max	
t_{CSCL}	CS_n high to first clock edge	300	—	—	ns
t_{CSZ}	CS_n high to tri-state on MISO	1	—	—	μ s

Figure 7. SPI timing specification

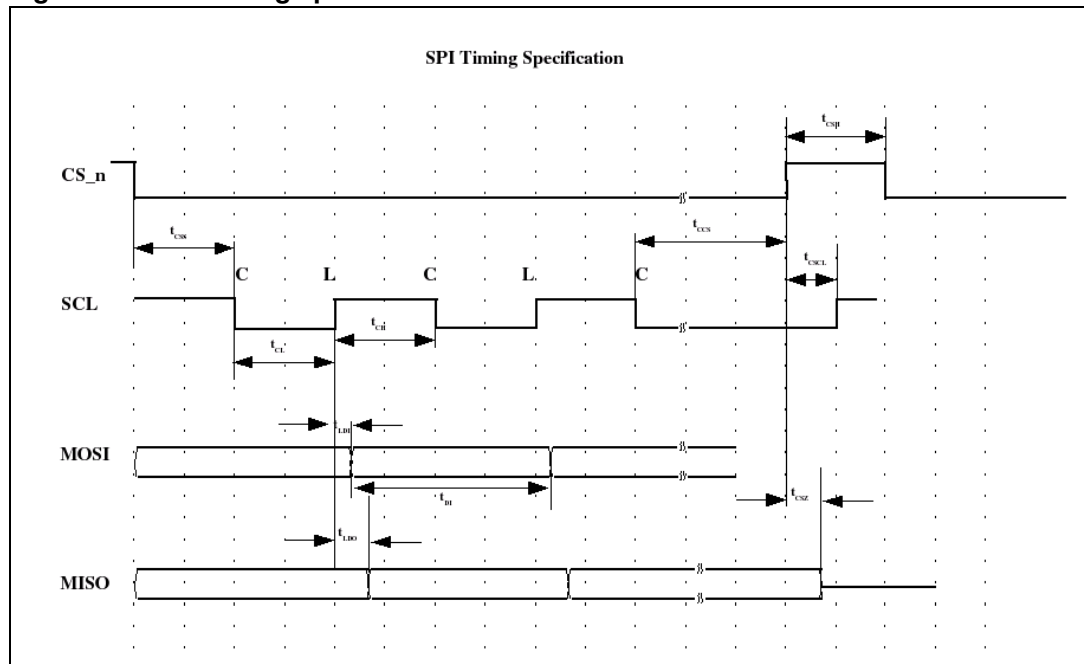

6 STMPE811 registers

This section lists and describes the registers of the STMPE811 device, starting with a register map and then provides detailed descriptions of register types.

Table 11. Register summary map table

Address	Register name	Bit	Type	Reset value	Function
0x00	CHIP_ID	16	R	0x0811	Device identification
0x02	ID_VER	8	R	0x03	Revision number 0x01 for engineering sample 0x03 for final silicon
0x03	SYS_CTRL1	8	R/W	0x00	Reset control
0x04	SYS_CTRL2	8	R/W	0x0F	Clock control
0x08	SPI_CFG	8	R/W	0x01	SPI interface configuration
0x09	INT_CTRL	8	R/W	0x00	Interrupt control register
0x0A	INT_EN	8	R/W	0x00	Interrupt enable register
0x0B	INT_STA	8	R	0x10	interrupt status register
0x0C	GPIO_EN	8	R/W	0x00	GPIO interrupt enable register
0x0D	GPIO_INT_STA	8	R	0x00	GPIO interrupt status register
0x0E	ADC_INT_EN	8	R/W	0x00	ADC interrupt enable register
0x0F	ADC_INT_STA	8	R	0x00	ADC interrupt status register
0x10	GPIO_SET_PIN	8	R/W	0x00	GPIO set pin register
0x11	GPIO_CLR_PIN	8	R/W	0x00	GPIO clear pin register
0x12	GPIO_MP_STA	8	R/W	0x00	GPIO monitor pin state register
0x13	GPIO_DIR	8	R/W	0x00	GPIO direction register
0x14	GPIO_ED	8	R/W	0x00	GPIO edge detect register
0x15	GPIO_RE	8	R/W	0x00	GPIO rising edge register
0x16	GPIO_FE	8	R/W	0x00	GPIO falling edge register
0x17	GPIO_AF	8	R/W	0x00	Alternate function register
0x20	ADC_CTRL1	8	R/W	0x9C	ADC control
0x21	ADC_CTRL2	8	R/W	0x01	ADC control
0x22	ADC_CAPT	8	R/W	0xFF	To initiate ADC data acquisition
0x30	ADC_DATA_CH0	16	R	0x0000	ADC channel 0
0x32	ADC_DATA_CH1	16	R	0x0000	ADC channel 1

Table 11. Register summary map table (continued)

Address	Register name	Bit	Type	Reset value	Function
0x34	ADC_DATA_CH2	16	R	0x0000	ADC channel 2
0x36	ADC_DATA_CH3	16	R	0x0000	ADC channel 3
0x38	ADC_DATA_CH4	16	R	0x0000	ADC channel 4
0x3A	ADC_DATA_CH5	16	R	0x0000	ADC channel 5
0x3C	ADC_DATA_CH6	16	R	0x0000	ADC channel 6
0x3E	ADC_DATA_CH7	16	R	0x0000	ADC channel 7
0x40	TSC_CTRL	8	R/W	0x90	4-wire touchscreen controller setup
0x41	TSC_CFG	8	R/W	0x00	Touchscreen controller configuration
0x42	WDW_TR_X	16	R/W	0x0FFF	Window setup for top right X
0x44	WDW_TR_Y	16	R/W	0x0FFF	Window setup for top right Y
0x46	WDW_BL_X	16	R/W	0x0000	Window setup for bottom left X
0x48	WDW_BL_Y	16	R/W	0x0000	Window setup for bottom left Y
0x4A	FIFO_TH	8	R/W	0x00	FIFO level to generate interrupt
0x4B	FIFO_STA	8	R/W	0x20	Current status of FIFO
0x4C	FIFO_SIZE	8	R	0x00	Current filled level of FIFO
0x4D	TSC_DATA_X	16	R	0x0000	Data port for touchscreen controller data access
0x4F	TSC_DATA_Y	16	R	0x0000	Data port for touchscreen controller data access
0x51	TSC_DATA_Z	8	R	0x0000	Data port for touchscreen controller data access
0x52	TSC_DATA_XYZ	32	R	0x00000000	Data port for touchscreen controller data access
0x56	TSC_FRACTION_Z	8		0x00	Touchscreen controller FRACTION_Z
0x57	TSC_DATA	8	R	0x00	Data port for touchscreen controller data access
0x58	TSC_I_DRIVE	8	R/W	0x00	Touchscreen controller drive I
0x59	TSC_SHIELD	8	R/W	0x00	Touchscreen controller shield
0x60	TEMP_CTRL	8	R/W	0x00	Temperature sensor setup

Table 11. Register summary map table (continued)

Address	Register name	Bit	Type	Reset value	Function
0x61	TEMP_DATA	8	R	0x00	Temperature data access port
0x62	TEMP_TH	8	R/W	0x00	Threshold for temperature controlled interrupt

7 System and identification registers

Table 12. System and identification registers map

Address	Register name	Bit	Type	Reset	Function
0x00	CHIP_ID	16	R	0x0811	Device identification
0x02	ID_VER	8	R	0x03	Revision number (0x03 for engineering sample)
0x03	SYS_CTRL1	8	R/W	0x00	Reset control
0x04	SYS_CTRL2	8	R/W	0x0F	Clock control
0x08	SPI_CFG	8	R/W	0x01	SPI interface configuration

CHIP_ID

Device identification

Address: 0x00
Type: R
Reset: 0x0811
Description: 16-bit device identification

ID_VER

Revision number

Address: 0x02
Type: R
Reset: 0x03 (0x01 for engineering samples)
Description: 16-bit revision number

SYS_CTRL1

Reset control

7	6	5	4	3	2	1	0
RESERVED						SOFT_RESET	HIBERNATE

Address: 0x03

Type: R/W

Reset: 0x00

Description: The reset control register enables to reset the device

[7:2] **RESERVED**

[1] **SOFT_RESET:** Reset the STMPE811 using the serial communication interface

[0] **HIBERNATE:** Force the device into hibernation mode.

Forcing the device into hibernation mode by writing '1' to this bit would disable the hot-key feature. If the hot-key feature is required, use the default auto-hibernation mode.

SYS_CTRL2

Clock control

7	6	5	4	3	2	1	0
-	-	-	-	TS_OFF	GPIO_OFF	TSC_OFF	ADC_OFF

Address: 0x04

Type: R/W

Reset: 0x0F

Description: This register enables to switch off the clock supply

[7:4] **RESERVED**

[3] **TS_OFF:** Switch off the clock supply to the temperature sensor
1: Switches off the clock supply to the temperature sensor

[2] **GPIO_OFF:** Switch off the clock supply to the GPIO
1: Switches off the clock supply to the GPIO

[1] **TSC_OFF:** Switch off the clock supply to the touchscreen controller
1: Switches off the clock supply to the touchscreen controller

[0] **ADC_OFF:** Switch off the clock supply to the ADC
1: Switches off the clock supply to the ADC

SPI_CFG**SPI interface configuration**

7	6	5	4	3	2	1	0
RESERVED				AUTO_INCR		SPI_CLK_MOD1	SPI_CLK_MOD0

Address: 0x08

Type: R/W

Reset: 0x01

Description: SPI interface configuration register

[7:3] **RESERVED**

[2] **AUTO_INCR:**

This bit defines whether the SPI transaction follows an addressing scheme that internally autoincrements or not

[1] **SPI_CLK_MOD1:**

This bit reflects the value of the SCAD/A0 pin during power-up reset

[0] **SPI_CLK_MOD0:**

This bit reflects the value of the SCAD/A0 pin during power-up reset

8 Interrupt system

The STMPE811 uses a 2-tier interrupt structure. The ADC interrupts and GPIO interrupts are ganged as a single bit in the “interrupt status register”. The interrupts from the touchscreen controller and temperature sensor can be seen directly in the interrupt status register.

Figure 8. Interrupt system diagram

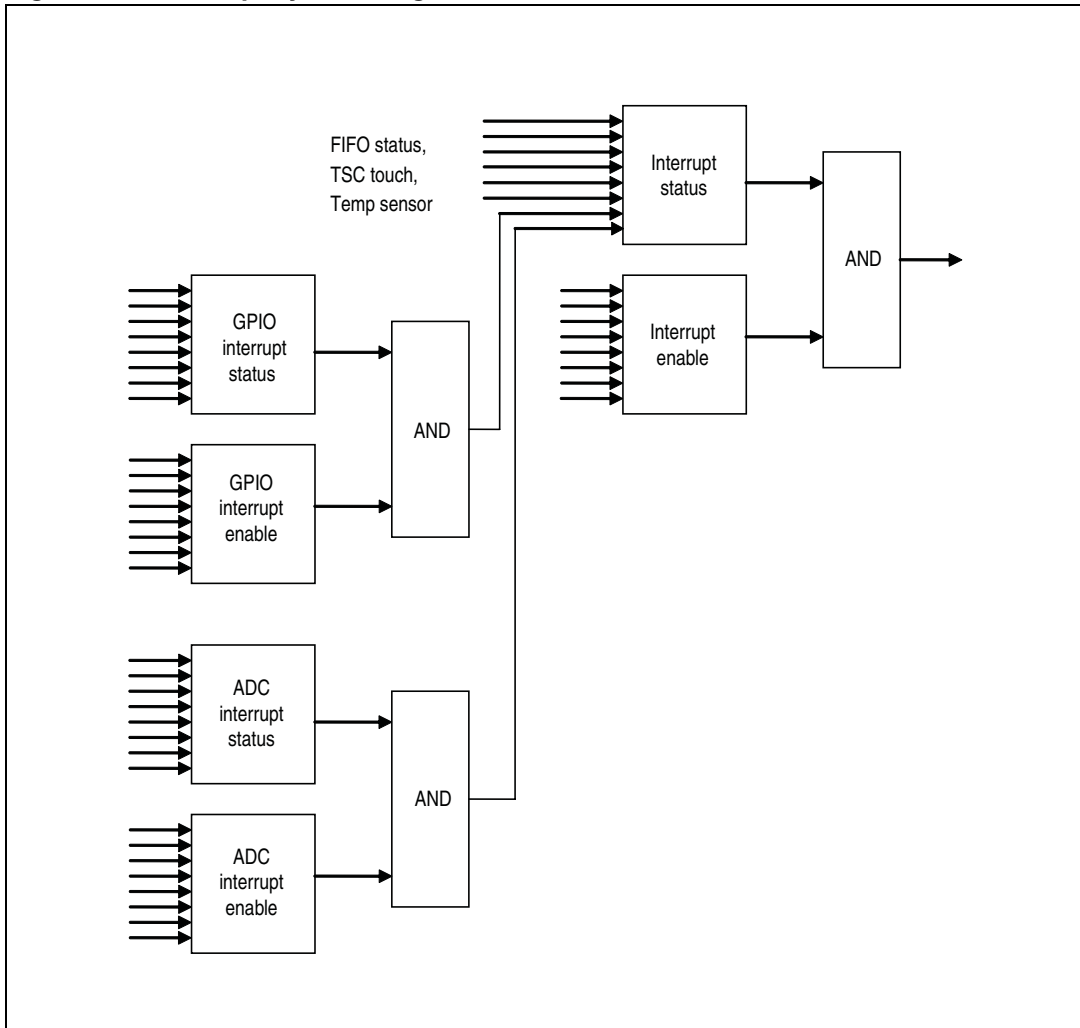

INT_CTRL**Interrupt control register**

7	6	5	4	3	2	1	0
RESERVED				INT_POLARITY	INT_TYPE	GLOBAL_INT	

Address: 0x09

Type: R/W

Reset: 0x00

Description: The interrupt control register is used to enable the interruption from a system-related interrupt source to the host.

[7:3] **RESERVED**

[2] **INT_POLARITY:** This bit sets the INT pin polarity

1: Active high/rising edge

0: Active low/falling edge

[1] **INT_TYPE:** This bit sets the type of interrupt signal required by the host

1: Edge interrupt

0: Level interrupt

[0] **GLOBAL_INT:** This is master enable for the interrupt system

1: Global interrupt

0: Stops all interrupts

INT_EN

Interrupt enable register

7	6	5	4	3	2	1	0
GPIO	ADC	TEMP_SENS	FIFO_EMPTY	FIFO_FULL	FIFO_OFLOW	FIFO_TH	TOUCH_DET

Address: 0x0A

Type: R/W

Reset: 0x00

Description: The interrupt enable register is used to enable the interruption from a system related interrupt source to the host.

- [7] **GPIO:** Any enabled GPIO interrupts
- [6] **ADC:** Any enabled ADC interrupts
- [5] **TEMP_SENS:** Temperature threshold triggering
- [4] **FIFO_EMPTY:** FIFO is empty
- [3] **FIFO_FULL:** FIFO is full
- [2] **FIFO_OFLOW:** FIFO is overflowed
- [1] **FIFO_TH:** FIFO is equal or above threshold value.
- [0] **TOUCH_DET:** Touch is detected

INT_STA

Interrupt status register

7	6	5	4	3	2	1	0
GPIO	ADC	TEMP_SENS	FIFO_EMPTY	FIFO_FULL	FIFO_OFLOW	FIFO_TH	TOUCH_DET

Address: 0x0B

Type: R

Reset: 0x10

Description: The interrupt status register monitors the status of the interruption from a particular interrupt source to the host. Regardless of whether the INT_EN bits are enabled, the INT_STA bits are still updated. Writing '1' to this register clears the corresponding bits. Writing '0' has no effect.

- [7] **GPIO:** Any enabled GPIO interrupts
- [6] **ADC:** Any enabled ADC interrupts
- [5] **TEMP_SENS:** Temperature threshold triggering
- [4] **FIFO_EMPTY:** FIFO is empty
- [3] **FIFO_FULL:** FIFO is full
- [2] **FIFO_OFLOW:** FIFO is overflowed
- [1] **FIFO_TH:** FIFO is equal or above threshold value.
This bit is set when FIFO level equals to threshold value. It will only be asserted again if FIFO level drops to < threshold value, and increased back to threshold value.
- [0] **TOUCH_DET:** Touch is detected

GPIO_INT_EN

GPIO interrupt enable register

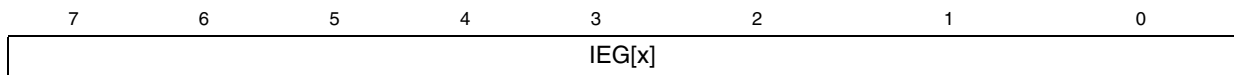

Address: 0x0C

Type: R/W

Reset: 0x10

Description: The interrupt status register monitors the status of the interruption from a particular interrupt source to the host. Regardless of whether the IER bits are enabled, the ISR bits are still updated. Writing '1' to this register clears the corresponding bits. Writing '0' has no effect.

- [7:0] IEG[x]: Interrupt enable GPIO mask (where x = 7 to 0)
- 1: Writing '1' to the IE[x] bit enables the interruption to the host

GPIO_INT_STA

GPIO interrupt status register

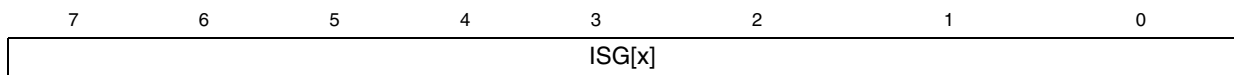

Address: 0x0D

Type: R/W

Reset: 0x00

Description: The GPIO interrupt status register monitors the status of the interruption from a particular GPIO pin interrupt source to the host. Regardless of whether or not the GPIO_STA bits are enabled, the GPIO_STA bits are still updated. The ISG[7:0] bits are the interrupt status bits corresponding to the GPIO[7:0] pins. Writing '1' to this register clears the corresponding bits. Writing '0' has no effect.

- [7:0] **ISG[x]**: GPIO interrupt status (where x = 7 to 0)
- Read:** Interrupt status of the GPIO[x]. Reading the register clears any bits that have been set to '1'
- Write:** Writing to this register has no effect

9 Analog-to-digital converter

An 8-input, 12-bit analog-to-digital converter (ADC) is integrated in the STMPE811. The ADC can be used as a generic analog-to-digital converter, or as a touchscreen controller capable of controlling a 4-wire resistive touchscreen.

Table 13. ADC controller register summary table

Address	Register name	Size	Description
0x20	ADC_CTRL1	8	ADC control
0x21	ADC_CTRL2	8	ADC control
0x22	ADC_CAPT	8	ADC channel data capture
0x30	ADC_DATA_CH0	8	ADC channel 0 (IN3/GPIO-3)
0x32	ADC_DATA_CH1	8	ADC channel 1 (IN2/GPIO-2)
0x34	ADC_DATA_CH2	8	ADC channel 2 (IN1/GPIO-1)
0x36	ADC_DATA_CH3	8	ADC channel 3 (IN0-GPIO-0)
0x38	ADC_DATA_CH4	8	ADC channel 4 (TSC)
0x3A	ADC_DATA_CH5	8	ADC channel 5 (TSC)
0x3C	ADC_DATA_CH6	8	ADC channel 6 (TSC)
0x3E	ADC_DATA_CH7	8	ADC channel 7 (TSC)

ADC_CTRL1**ADC control 1**

7	6	5	4	3	2	1	0
RESERVED	SAMPLE_TIME2	SAMPLE_TIME1	SAMPLE_TIME0	MOD_12B	RESERVED	REF_SEL	RESERVED

Address: 0x20

Type: R/W

Reset: 0x9C

Description: ADC control register.

[7] **RESERVED**

[6:4] **SAMPLE_TIME**_n: ADC conversion time in number of clock

000: 36

001: 44

010: 56

011: 64

100: 80

101: 96

110: 124

111: Not valid

[3] **MOD_12B**: Selects 10 or 12-bit ADC operation

1: 12 bit ADC

0: 10 bit ADC

[2] **RESERVED**

[1] **REF_SEL**: Selects between internal or external reference for the ADC

1: External reference

0: Internal reference

[0] **RESERVED**

ADC_CTRL2

ADC control 2

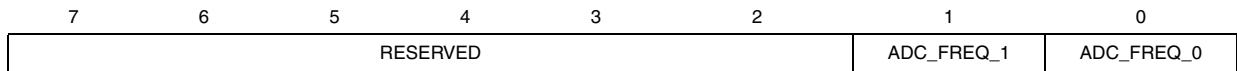

Address: 0x21
Type: R/W
Reset: 0x01
Description: ADC control.

- [7] **RESERVED**
- [6] **RESERVED**
- [5] **RESERVED**
- [4] **RESERVED**
- [3] **RESERVED**
- [2] **RESERVED**
- [1:0] **ADC_FREQ:** Selects the clock speed of ADC
 - 00: 1.625 MHz typ.
 - 01: 3.25 MHz typ.
 - 10: 6.5 MHz typ.
 - 11: 6.5 MHz typ.

ADC_CAPT

ADC channel data capture

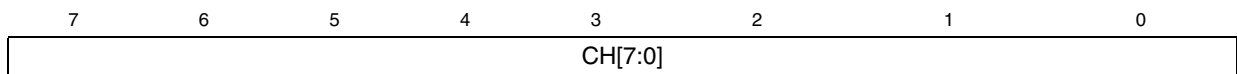

Address: 0x22
Type: R/W
Reset: 0xFF
Description: To initiate ADC data acquisition.

- [7:0] **CH[7:0]:** ADC channel data capture
 - Write '1' to initiate data acquisition for the corresponding channel. Writing '0' has no effect.
 - Reads '1' if conversion is completed. Reads '0' if conversion is in progress.

ADC_DATA_CHn

ADC channel data registers

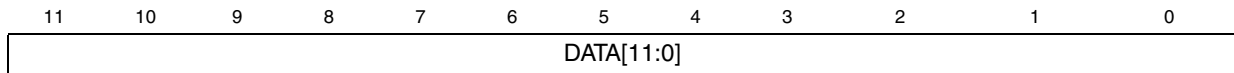

Address: Add address

Type: R/W

Reset: 0x0000

Description: ADC data register 0-7 (DATA_CHn=0 -7)

[11:0] **DATA[11:0]:** ADC channel data

If TSC is enabled, CH3-0 is used for TSC and all readings to these channels give 0x0000

The ADC in STMPE811 operates on an internal RC clock with a typical frequency of 6.5 MHz. The total conversion time in ADC mode depends on the "SampleTime" setting, and the clock division field 'Freq'.

The following table shows the conversion time based on 6.5 MHz, 3.25 MHz and 1.625 MHz clock.

Table 14. ADC conversion time

Sample time setting	Conversion time in ADC clock	6.5 MHz (154 ns)	3.25 MHz (308 ns)	1.625 MHz (615 ns)
000	36	5.5 μs (180 kHz)	11 μs (90 kHz)	22 μs (45 kHz)
001	44	6.8 μs (147 kHz)	13.6 μs (74 kHz)	27 μs (36 kHz)
010	56	8.6 μs (116 kHz)	17.2 μs (58 kHz)	34.4 μs (29 kHz)
011	64	9.9 μs (101 kHz)	19.8 μs (51 kHz)	39.6 μs (25 kHz)
100	80	12.3 μs(81.5 kHz)	24.6 μs (41 kHz)	49.2 μs (20 kHz)
101	96	14.8 μs (67.6 kHz)	28.8 μs (33 kHz)	59.2 μs (17 kHz)
110	124	19.1 μs (52.3 kHz)	38.2 μs (26 kHz)	56.4 μs (13 kHz)

10 Touchscreen controller

The STMPE811 is integrated with a hard-wired touchscreen controller for 4-wire resistive type touchscreen. The touchscreen controller is able to operate completely autonomously, and interrupt the connected CPU only when a pre-defined event occurs.

Figure 9. Touchscreen controller block diagram

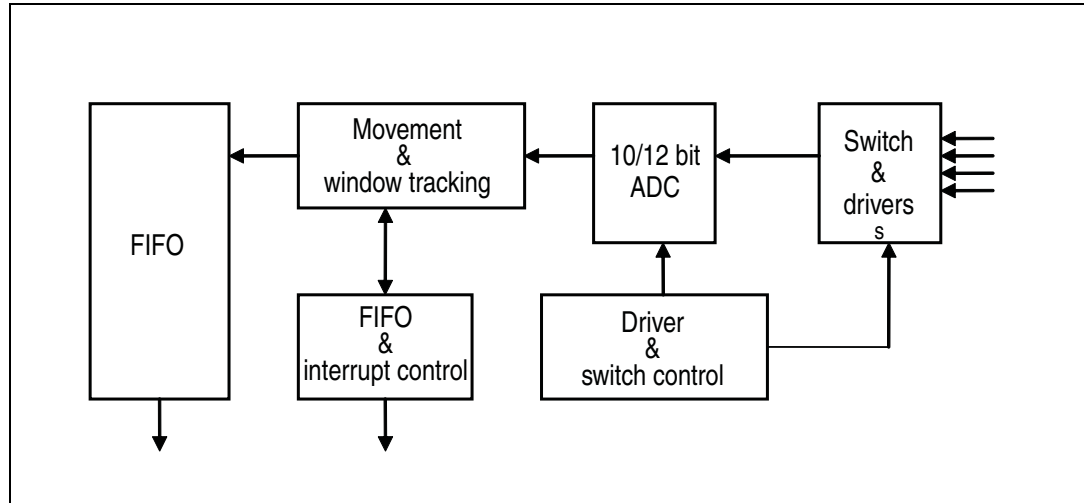

10.1 Driver and switch control unit

The driver and switch control unit allows coordination of the ADC and the MUX/switch. With the coordination of this unit, a stream of data is produced at a selected frequency.

The touchscreen drivers can be configured with 2 current ratings: 20 mA or 50 mA. In the case where multiple touch-down on the screen is causing a short, the current from the driver is limited to these values. Tolerance of these current setting is +/- 25%.

Movement tracking

The "Tracking Index" in the TSC_CTRL register specifies a value, which determines the distance between the current touch position and the previous touch position. If the distance is shorter than the tracking index, it is discarded.

The tracking is calculated by summation of the horizontal and vertical movement. Movement is only reported if:

$$(Current\ X - Previously\ Reported\ X) + (Current\ Y - Previously\ Reported\ Y) > Tracking\ Index$$

If pressure reporting is enabled (X/Y/Z), an increase in pressure override the movement tracking and report the new data set, even if X/Y is within the previous tracking index. This is to ensure that a slow touch is not discarded.

If pressure data is not used, select X/Y mode in touchscreen data acquisition. (Opmode field in TSCControl register).

Window tracking

The -WDW_X and WDW_Y registers allow to pre-set a sub-window in the touchscreen such that any touch position that is outside the sub-window is discarded.

Figure 10. Window tracking

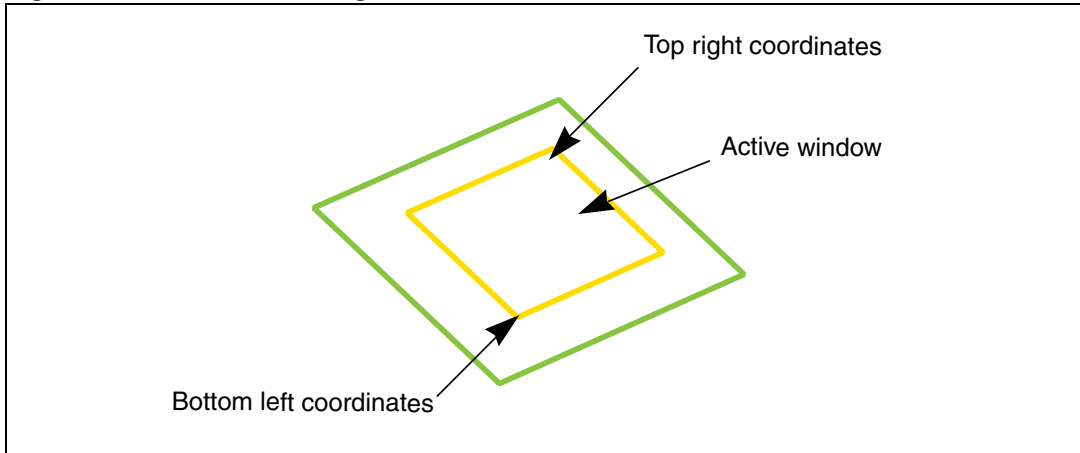

FIFO

FIFO has a depth of 128 sectors. This is enough for 128 sets of touch data at maximum resolution (2 x 12 bits). FIFO can be programmed to generate an interrupt when it is filled to a pre-determined level.

Sampling

The STMPE811 touchscreen controller has an internal 180 kHz, 12-bit ADC able to execute autonomous driving/sampling. Each "sample" consists of 4 ADC readings that provide the X and Y locations, as well as the touch pressure.

Figure 11. Sampling

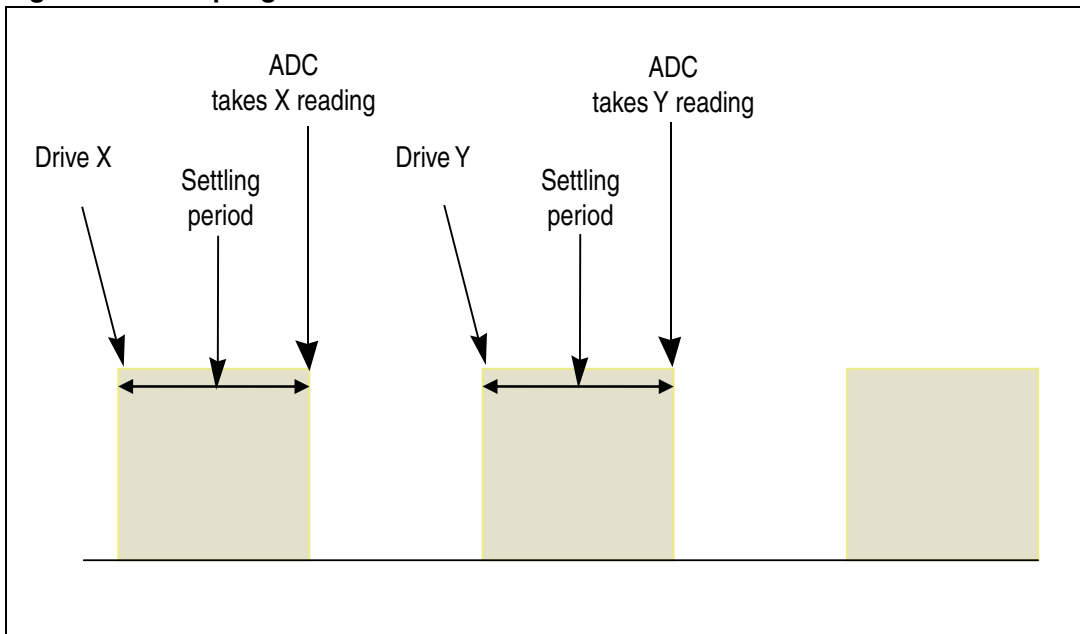

Oversampling and averaging function

The STMPE811 touchscreen controller can be configured to oversample by 2/4/8 times and provide the averaged value as final output. This feature helps to reduce the effect of surrounding noise.

Table 15. Touchscreen controller register summary table

Address	Register name	Bit	Type	Function
0x40	TSC_CTRL	8	R/W	4-wire touchscreen controller setup
0x41	TSC_CFG	8	R/W	TSC configuration register
0x42	WDW_TR_X	16	R/W	Window setup for top right X
0x44	WDW_TR_Y	16	R/W	Window setup for top right Y
0x46	WDW_TR_X	16	R/W	Window setup for bottom left X
0x48	WDW_TR_Y	16	R/W	Window setup for bottom left Y
0x4A	FIFO_TH	8	R/W	FIFO level to generate interrupt
0x4B	FIFO_STA	8	R/W	Current status of FIFO
0x4C	FIFO_SIZE	8	R	Current filled level of FIFO
0x4D	TSC_DATA_X	16	R	Data port for TSC data access
0x4F	TSC_DATA_Y	16	R	Data port for TSC data access
0x51	TSC_DATA_Z	8	R	Data port for TSC data access
0x52	TSC_DATA_XYZ	32	R	Data port for TSC data access
0x56	TSC_FRACT_Z	8	R/W	Touchscreen controller FRACTION_Z
0x57	TSC_DATA	8	R	Touchscreen controller data access port
0x58	TSC_I_DRIVE	8	R/W	Touchscreen controller drive I
0x59	TSC_SHIELD	8	R/W	Touchscreen controller shield

TSC_CTRL **touchscreen controller control register**

	7	6	5	4	3	2	1	0
	TSC_STA	TRACK			OP_MOD			EN

Address: 0x40

Type: R/W

Reset: 0x90

Description: 4-wire touchscreen controller (TSC) setup.

[7] **TSC_STA:** TSC status
 Reads '1' when touch is detected
 Reads '0' when touch is not detected
 Writing to this register has no effect

[6:4] **TRACK:** Tracking index
 000: No window tracking
 001: 4
 010: 8
 011: 16
 100: 32
 101: 64
 110: 92
 111: 127

[3:1] **OP_MOD:** TSC operating mode
 000: X, Y, Z acquisition
 001: X, Y only
 010: X only
 011: Y only
 100: Z only
 This field cannot be written on, when EN = 1

[0] **EN:** Enable TSC

TSC_CFG

Touchscreen controller configuration register

7	6	5	4	3	2	1	0
AVE_CTRL_1	AVE_CTRL_0	TOUCH_DET_DELAY_2	TOUCH_DET_DELAY_1	TOUCH_DET_DELAY_0	SETTLING_2	SETTLING_1	SETTLING_0

Address: 0x41

Type: R/W

Description: Touchscreen controller configuration register.

[7:6] **AVE_CTRL_1/0:** Average control

- 00=1 sample
- 01=2 samples
- 10=4 samples
- 11=8 samples

[5:3] **TOUCH_DET_DELAY_2/1/0:** Touch detect delay

- 000 - 10 μs
- 001 - 50 μs
- 010 = 100 μs
- 011 = 500 μs
- 100 = 1 ms
- 101 = 5 ms
- 110 = 10 ms
- 111 = 50 ms

[2:0] **SETTLING:** Panel driver settling time⁽¹⁾

- 000 = 10 μs
- 001 = 100 μs
- 010 = 500 μs
- 011 = 1 ms
- 100 = 5 ms
- 101 = 10 ms
- 110 = 50 ms
- 111 = 100 ms

1. For large panels (> 6"), a capacitor of 10 nF is recommended at the touchscreen terminals for noise filtering. In this case, settling time of 1 ms or more is recommended.

WDW_TR_X

Window setup for top right X

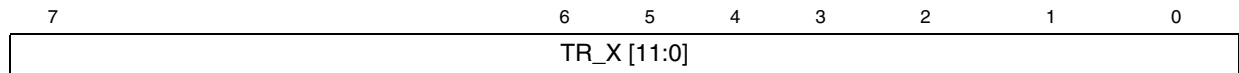

Address: 0x42

Type: R/W

Reset: 0x0FFF

Description: Window setup for top right X coordinates.
 [11:0] TR_X: Bit 11:0 of top right X coordinates

WDW_TR_Y

Window setup for top right Y

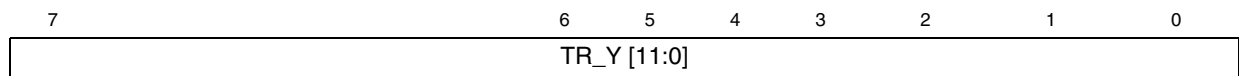

Address: 0x44

Type: R/W

Reset: 0x0FFF

Description: Window setup for top right Y coordinates.
 [11:0] TR_X: Bit 11:0 of top right Y coordinates

WDW_BL_X

Window setup for bottom left X

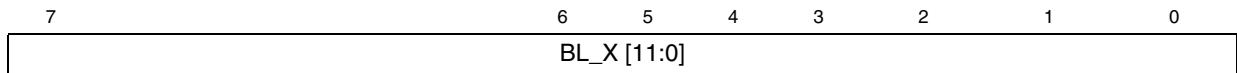

Address: 0x46
Type: R/W
Reset: 0x0000
Description: Window setup for bottom left X coordinates.
 [11:0] BL_X: Bit 11:0 of bottom left X coordinates

WDW_BL_Y

Window setup for bottom left Y

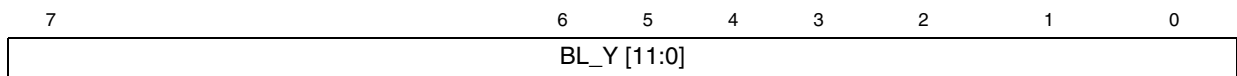

Address: 0x48
Type: R/W
Reset: 0x0000
Description: Window setup for bottom left Y coordinates.
 [11:0] **BL_X**: Bit 11:0 of bottom left Y coordinates

FIFO_TH

FIFO threshold

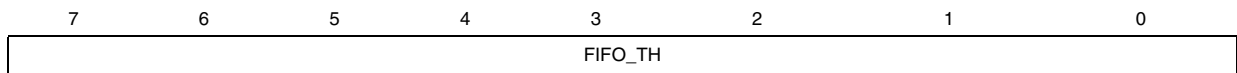

Address: 0x4A
Type: R/W
Reset: 0x00
Description: Triggers an interrupt upon reaching or exceeding the threshold value. This field must not be set as zero.
 [7:0] **FIFO_TH**: touchscreen controller FIFO threshold

FIFO_STA

FIFO status

7	6	5	4	3	2	1	0
FIFO_OFLOW	FIFO_FULL	FIFO_EMPTY	FIFO_TH_TRIG	RESERVED			FIFO_RESET

Address: 0x4B

Type: R/W

Reset: 0x20

Description: Current status of FIFO..

- [7] **FIFO_OFLOW:**
Reads 1 if FIFO is overflow
- [6] **FIFO_FULL:**
Reads 1 if FIFO is full
- [5] **FIFO_EMPTY:**
Reads 1 if FIFO is empty
- [4] **FIFO_TH_TRIG:**
0 = Current FIFO size is still below the threshold value
1 = Current FIFO size is at or beyond the threshold value
- [3:1] RESERVED
- [0] **FIFO_RESET:**
Write '0' : FIFO put out of reset mode
Write '1' : Resets FIFO. All data in FIFO are cleared.
When TSC is enabled, FIFO resets automatically.

FIFO_SIZE

FIFO size

7	6	5	4	3	2	1	0
RESERVED	FIFO_SIZE						

Address: 0x4C

Type: R

Reset: 0x00

Description: Current number of samples available.

- [7:0] **FIFO_SIZE:** Number of samples available

TSC_DATA_X

TSC_DATA_X

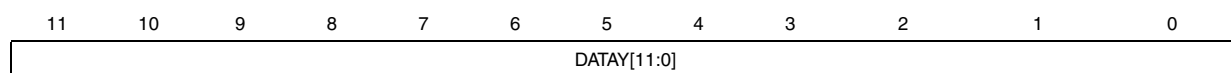

Address: 0x4D

Type: R

Reset: 0x0000

Description: Bit 11:0 of X data.

[11:0] **DATAY[11:0]**: Bit 11:0 of X data

TSC_DATA_Y

TSC_DATA_Y

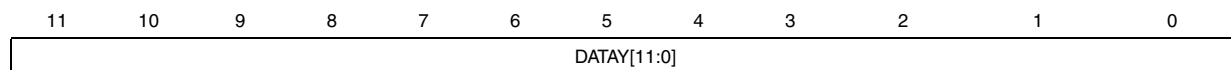

Address: 0x4F
Type: R
Reset: 0x0000
Description: Bit 11:0 of Y data.
 [11:0] **DATAY[11:0]**: bit 11:0 of Y data

TSC_DATA_Z

TSC_DATA_Z

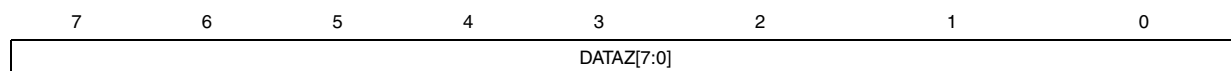

Address: 0x51
Type: R
Reset: 0x0000
Description: Bit 7:0 of Z data.
 [7:0] **DATAZ[7:0]**: bit 7:0 of Z data

TSC_DATA_XYZ

Touchscreen controller DATA

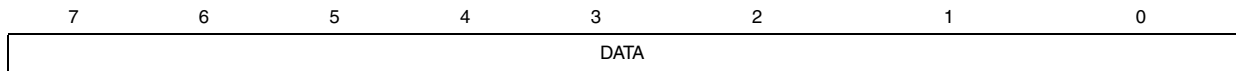

Address: 0x57 (auto-increment), 0xD7 (non-auto-increment)

Type: R

Reset: 0x00

Description: Data port for TSC data access

[11:0] **DATA:** data bytes from TSC FIFO

The data format from the TSC_DATA register depends on the setting of "OpMode" field in TSC_CTRL register. The samples acquired are accessed in "packed samples". The size of each "packed sample" depends on which mode the touchscreen controller is operating in.

The TSC_DATA register can be accessed in 2 modes:

- Autoincrement
- Non autoincrement

To access the 128-sets buffer, the non autoincrement mode should be used.

Table 16. Touchscreen controller DATA register

TSC_CTRL in operation mode	Number of bytes to read from TSC_DATA_XYZ	Byte0	Byte1	Byte2	Byte3
000	4	[11:4] of X	[3:0] of X [11:8] of Y	[7:0] of Y	[7:0] of Z
001	3	[11:4] of X	[3:0] of X [11:8] of Y	[7:0] of Y	—
010	2	[11:4] of X	[3:0] of X	—	—
011	2	[11:4] of Y	[3:0] of Y	—	—
100	1	[7:0] of Z	-	—	—

TSC_FRACTION_Z

Touchscreen controller FRACTION_Z

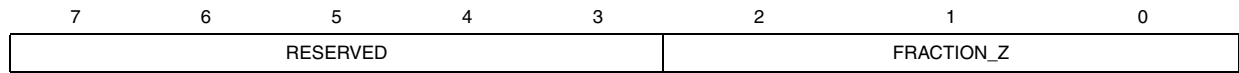

Address: 0x56

Type: R

Reset: 0x00

Description: This register allows to select the range and accuracy of the pressure measurement

[7:3] **RESERVED**

[2:0] **FRACTION_Z:**

- 000: Fractional part is 0, whole part is 8
- 001: Fractional part is 1, whole part is 7
- 010: Fractional part is 2, whole part is 6
- 011: Fractional part is 3, whole part is 5
- 100: Fractional part is 4, whole part is 4
- 101: Fractional part is 5, whole part is 3
- 110: Fractional part is 6, whole part is 2
- 111: Fractional part is 7, whole part is 1

TSC_I_DRIVE

Touchscreen controller drive I

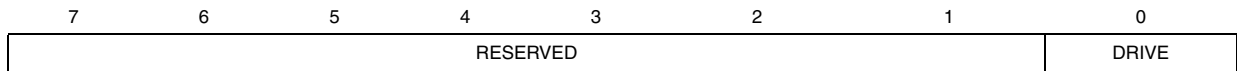

Address: 0x58

Type: R/W

Reset: 0x00

Description: This register sets the current limit value of the touchscreen drivers

[7:1] **RESERVED**

[0] **DRIVE:** maximum current on the touchscreen controller (TSC) driving channel

0: 20 mA typical, 35 mA max

1: 50 mA typical, 80 mA max

TSC_SHIELD

Touchscreen controller shield

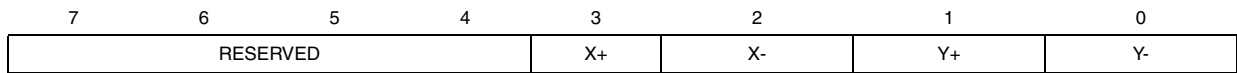

Address: 0x59

Type: R

Reset: 0x00

Description: Writing each bit would ground the corresponding touchscreen wire

[7:4] **RESERVED**

[3:0] **SHIELD[3:0]:**

Write 1 to GND X+, X-, Y+, Y- lines

11 Touchscreen controller programming sequence

The following are the steps to configure the touchscreen controller (TSC):

- a) Disable the clock gating for the touchscreen controller and ADC in the SYS_CFG2 register.
- b) Configure the touchscreen operating mode and the window tracking index.
- c) A touch detection status may also be enabled through enabling the corresponding interrupt flag. With this interrupt, the user is informed through an interrupt when the touch is detected as well as lifted.
- d) Configure the TSC_CFG register to specify the “panel voltage settling time”, touch detection delays and the averaging method used.
- e) A windowing feature may also be enabled through TSCWdwTRX, TSCWdwTRY, TSCWdwBLX and TSCWdwBLY registers. By default, the windowing covers the entire touch panel.
- f) Configure the TSC_FIFO_TH register to specify the threshold value to cause an interrupt. The corresponding interrupt bit in the interrupt module must also be enabled. This interrupt bit should be masked off during data fetching from the FIFO in order to prevent an unnecessary trigger of this interrupt. Upon completion of the data fetching, this bit can be re-enabled.
- g) By default, the FIFO_RESET bit in the TSC_FIFO_CTRL_STA register holds the FIFO in Reset mode. Upon enabling the touchscreen controller (through the EN bit in TSC_CTRL), this FIFO reset is automatically deasserted. The FIFO status may be observed from the TSC_FIFO_CTRL_STA register or alternatively through the interrupt.
- h) Once the data is filled beyond the FIFO threshold value, an interrupt is triggered (assuming the corresponding interrupt is being enabled). The user is required to continuously read out the data set until the current FIFO size is below the threshold, then, the user may clear the interrupt flag. As long as the current FIFO size exceeds the threshold value, an interrupt from the touchscreen controller is sent to the interrupt module. Therefore, even if the interrupt flag is cleared, the interrupt flag is automatically asserted, as long as the FIFO size exceeds the threshold value.
- i) The current FIFO size can be obtained from the TSC_FIFO_Sz register. This information may assist the user in how many data sets are to be read out from the FIFO, if the user intends to read all in one shot. The user may also read a data set by a data set.
- j) The TSC_DATA_X register holds the X-coordinates. This register can be used in all touchscreen operating modes.
- k) The TSC_DATA_Y register holds the Y-coordinates. TSC_DATA_Y register holds the Y-coordinates.
- l) The TSC_DATA_Z register holds the Z value. TSC_DATA_Z register holds the Z-coordinates.
- m) The TSCDATA_XYZ register holds the X, Y and Z values. These values are packed into 4 bytes. This register can only be used when the touchscreen operating mode is 000 and 001. This register is to facilitate less byte read.
- n) For the TSC_FRACT_Z register, the user may configure it based on the touchscreen panel resistance. This allows the user to specify the resolution of the

Z value. With the Z value obtained from the register, the user simply needs to multiply the Z value with the touchscreen panel resistance to obtain the touch resistance.

- o) The TSC_DATA register allows facilitation of another reading format with minimum I²C transaction overhead by using the non autoincrement mode (or equivalent mode in SPI). The data format is the same as TSC_DATA_XYZ, with the exception that all the data fetched are from the same address.
- p) Enable the EN bit of the TSC_CTRL register to start the touch detection and data acquisition.
- q) During the auto-hibernate mode, a touch detection can cause a wake-up to the device only when the TSC is enabled and the touch detect status interrupt mask is enabled.
- r) In order to prevent confusion, it is recommended that the user not mix the data fetching format (TSC_DATA_X, TSC_DATA_Y, TSC_DATA_Z, TSC_DATA_XYZ and TSC_DATA) between one reading and the next.
- s) It is also recommended that the user should perform a FIFO reset and TSC disabling when the ADC or TSC setting are reconfigured.

12 Temperature sensor

The STMPE811 internal temperature sensor can be used as a reference for compensation of the touchscreen parameters. Temperature measurement is optimised for temperature from 0 °C to 85 °C.

Table 17. Touchscreen parameters

Address	Register name	Bit	Function
0x60	TEMP_CTRL	8	Temperature sensor setup
0x61	TEMP_DATA	16	Temperature data access port
0x62	TEMP_TH	16	Threshold for temperature controlled interrupt

TEMP_CTRL

Temperature sensor setup

7	6	5	4	3	2	1	0
RESERVED			THRES_RANGE	THRES_EN	ACQ_MOD	ACQ	ENABLE

Address: 0x60

Type: R/W

Reset: 0x00

Description: Temperature sensor setup

[7:5] RESERVED

[4] **THRES_RANGE:**

'0' assert interrupt if temperature is >= threshold

'1' assert interrupt if otherwise

[3] **THRES_EN:** temperature threshold enable

[2] **ACQ_MOD:**

'0' to acquire temperature for once only

'1' to acquire temperature every 10mS

[1] **ACQ**

[0] **ENABLE**

TEMP_DATA

Temperature data

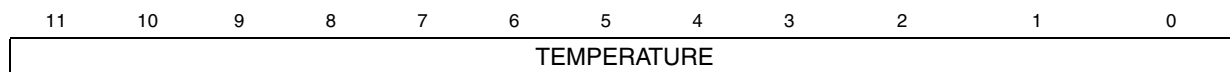

Address: 0x61

Type: R

Reset: 0x00

Description: Temperature data access port

[11:0] **TEMPERATURE:** Temperature reading

Absolute temperature

= (V_{IO} * temperature [11:0]) / 7.51 (12-bit ADC)

= (V_{IO} * temperature [9:0]) / 7.51 (10-bit ADC)

Note that V_{IO} is used as a reference in temperature acquisition.

Variations in V_{IO} directly affect the accuracy of temperature acquired.

TEMP_TH

Temperature threshold

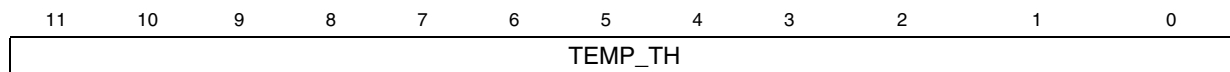

Address: 0x62

Type: R/W

Reset: 0x00

Description: Threshold for temperature controlled interrupt

[11:0] **TEMP_TH:** temperature threshold

13 GPIO controller

A total of 8 GPIOs are available in the STMPE811 port expander device. Most of the GPIOs share physical pins with some alternate functions. The GPIO controller contains the registers that allow the host system to configure each of the pins into either a GPIO, or one of the alternate functions. Unused GPIOs should be configured as outputs to minimize power consumption.

A group of registers are used to control the exact function of each of the 8 GPIOs. The registers and their respective addresses are listed in the following table.

Table 18. GPIO control registers

Address	Register name	Size (bit)	Function
0x10	GPIO_SET_PIN	8	Set pin register
0x11	GPIO_CLR_PIN	8	Clear pin state
0x12	GPIO_MP_STA	8	Monitor pin state
0x13	GPIO_DIR	8	Set pin direction
0x14	GPIO_ED	8	Edge detect status
0x15	GPIO_RE	8	Rising edge detection enable
0x16	GPIO_FE	8	Falling edge detection enable
0x17	GPIO_ALT_FUNCT	8	Alternate function register

All GPIO registers are named as GPIO-x, where x represents the functional group.

7	6	5	4	3	2	1	0
GPIO-7	GPIO-6	GPIO-5	GPIO-4	GPIO-3	GPIO-2	GPIO-1	GPIO-0

GPIO_SET_PIN**GPIO set pin register****Address:** 0x10**Type:** R/W**Reset:** 0x00**Description:** GPIO set pin register.

Writing 1 to this bit causes the corresponding GPIO to go to 1 state.

Writing 0 has no effect.

GPIO_CLR_PIN**Clear pin state register****Address:** 0x11**Type:** R/W**Reset:** 0x00**Description:** GPIO clear pin state register.

Writing '1' to this bit causes the corresponding GPIO to go to 0 state.

Writing '0' has no effect.

GPIO_MP_STA**GPIO monitor pin state register****Address:** 0x12**Type:** R/W**Reset:** 0x00**Description:** GPIO monitor pin state.

Reading this bit yields the current state of the bit. Writing has no effect.

GPIO_DIR**GPIO set pin direction****Address:** 0x13**Type:** R/W**Reset:** 0x00**Description:** GPIO set pin direction register.

Writing '0' sets the corresponding GPIO to input state, and '1' sets it to output state.

All bits are '0' on reset.

GPIO_ED_STA**GPIO edge detect status****Address:** 0x14**Type:** R/W**Reset:** 0x00**Description:** GPIO edge detect status register. An edge transition has been detected.**GPIO_RE****Rising edge register****Address:** 0x15**Type:** R/W**Reset:** 0x00**Description:** GPIO rising edge detection enable register.
Setting this bit to '1' would enable the detection of the rising edge transition.
The detection would be reflected in the GPIO edge detect status register.**GPIO_FE****Falling edge detection enable register****Address:** 0x16**Type:** R/W**Reset:** 0x00**Description:** Setting this bit to '1' would enable the detection of the falling edge transition.
The detection would be reflected in the GPIO edge detect status register.**GPIO_ALT_FUNCT****Alternate function register****Address:** 0x17**Type:** R/W**Reset:** 0x0F**Description:** Alternate function register. "0" sets the corresponding pin to function as touchscreen/ADC, and '1' sets it into GPIO mode.**13.0.1 Power supply**

The STMPE811 GPIO operates from a separate supply pin (V_{IO}). This dedicated supply pin provides a level-shifting feature to the STMPE811. The GPIO remains valid until V_{IO} is removed.

The host system may choose to turn off V_{CC} supply while keeping V_{IO} supplied. However it is not allowed to turn off supply to V_{IO} , while keeping the V_{CC} supplied.

The touchscreen is always powered by V_{IO} . For better resolution and noise immunity, V_{IO} above 2.8 V is advised.

13.0.2 Power-up reset (POR)

The STMPE811 is equipped with an internal POR circuit that holds the device in reset state, until the V_{IO} supply input is valid. The internal POR is tied to the V_{IO} supply pin.

On power-up reset, all GPIOs are set as input.

14 Maximum rating

Stressing the device above the ratings listed in the “Absolute maximum ratings” table may cause permanent damage to the device. These are stress ratings only, and operation of the device at these or any other conditions above those indicated in the operating sections of this specification is not implied. Exposure to absolute maximum rating conditions for extended periods may affect the device’s reliability.

Table 19. Absolute maximum ratings

Symbol	Parameter	Value	Unit
V _{CC}	Supply voltage	4.5	V
V _{IO}	GPIO supply voltage	4.5	V
ESD	ESD protection on each GPIO pin (air discharge)	4	kV
T	Operating temperature	-40 - 85	°C
T _{STG}	Storage temperature	-65 - 155	°C
T _J	Thermal resistance junction-ambient	96	°C/W

14.1 Recommended operating conditions

Table 20. Power consumption

Symbol	Parameter	Test condition	Value			Unit
			Min	Typ	Max	
V _{CC}	Core supply voltage	V _{IO} ≥ V _{CC}	1.65	–	3.6	V
V _{IO}	I/O supply voltage		1.65	–	3.6	V
I _{CC-active}	Core supply current	Touchscreen controller at 100 Hz sampling V _{CC} = 1.8 – 3.3 V	–	0.5	1.0	μA
I _{IO-active}	I/O supply current	Touchscreen controller at 100 Hz sampling V _{IO} = 1.8 V	–	0.8	1.2	mA
I _{IO-active}	I/O supply current	Touchscreen controller at 100 Hz sampling V _{IO} = 3.3 V	–	2.0	2.8	mA
I _{CC-hibernate}	Core supply current	Hibernate state, no I2C/SPI activity V _{CC} = 1.8 V	–	0.5	1	μA
I _{IO-hibernate}	I/O supply current	Hibernate state, no I2C/SPI activity V _{IO} = 1.8 – 3.3 V	–	0.5	1	μA
		Hibernate state, no I2C/SPI activity V _{IO} = 3.3 V	–	1.0	3.0	μA

15 Electrical specifications

Table 21. DC electrical characteristics (-40 °C to 85 °C) all GPIOs comply to JEDEC standard JESD-8-7)

Symbol	Parameter	Test condition	Value			Unit
			Min	Typ	Max	
V_{IL}	Input voltage low state	$V_{IO} = 1.8 - 3.3 \text{ V}$	-0.3 V	–	$0.20 V_{IO}$	V
V_{IH}	Input voltage high state	$V_{IO} = 1.8 - 3.3 \text{ V}$	$0.80 V_{IO}$	–	$V_{IO} + 0.3 \text{ V}$	V
V_{OL}	Output voltage low state	$V_{IO} = 1.8 \text{ V}$, $I_{OL} = 4 \text{ mA}$ $V_{IO} = 3.3 \text{ V}$, $I_{OL} = 8 \text{ mA}$	-0.3 V	–	$0.15 V_{IO}$	V
V_{OH}	Output voltage high state		$0.85 V_{IO}$	–	–	V
V_{OL} (I ² C/SPI)	Output voltage low state	$V_{CC} = 1.8 \text{ V}$, $I_{OL} = 4 \text{ mA}$	-0.3 V	–	$0.15 V_{CC}$	V
V_{OH} (I ² C/SPI)	Output voltage high state	$V_{CC} = 3.3 \text{ V}$, $I_{OL} = 8 \text{ mA}$	$0.85 V_{CC}$	–	$V_{CC} + 0.3 \text{ V}$	V

Table 22. AC electrical characteristics (-40 °C to 85 °C)

Symbol	Parameter	Test condition	Value			Unit
			Min	Typ	Max	
$CLKI2C_{max}$	I ² C maximum SCLK	$V_{IO} = 1.8 - 3.3 \text{ V}$	400	–	–	kHz
$CLKSPI_{max}$	SPI maximum clock	$V_{IO} = 1.8 \text{ V}$	800	–	–	kHz
		$V_{IO} = 3.3 \text{ V}$	1000	–	–	kHz

Table 23. ADC specification (-40 °C to 85 °C)

Parameter	Test condition	Value			Unit
		Min	Typ	Max	
Full-scale input span		0	–	V_{ref}	V
Absolute input range		–	–	$V_{CC} + 0.2$	V
Input capacitance		–	25	–	pF
Leakage current		–	0.1	–	μA
Resolution		–	12	–	Bits
No missing codes		11		–	Bits
Integral linearity error		–	±4	–	Bits
Offset error		–	±5	–	LSB
Gain error		–	±14	±18	LSB
Noise	Including internal V_{ref}	–	70	–	μVrms
Power supply rejection ratio		–	50	–	dB
Throughput rate		–	180	–	ksps

Table 24. Switch drivers specification

Parameter	Test condition	Value			Unit
		Min	Typ	Max	
ON resistance X+, Y+		–	5.5	–	Ω
ON resistance X-, Y-		–	7.3	–	Ω
Drive current	Duration 100 ms	–	–	50	mA

Table 25. Voltage reference specification

Parameter	Test condition	Value			Unit
		Min	Typ	Max	
Internal reference voltage		2.45	2.50	2.55	V
Internal reference drift		–	25	–	Ppm/C
Output impedance	Internal reference ON	–	300	–	Ω
	Internal reference OFF	–	1	–	GΩ

16 Package mechanical data

In order to meet environmental requirements, ST offers these devices in different grades of ECOPACK[®] packages, depending on their level of environmental compliance. ECOPACK[®] specifications, grade definitions and product status are available at: www.st.com. ECOPACK[®] is an ST trademark.

Figure 12. Package outline for QFN16 (3 x 3 x 1 mm) - 0.50 pitch

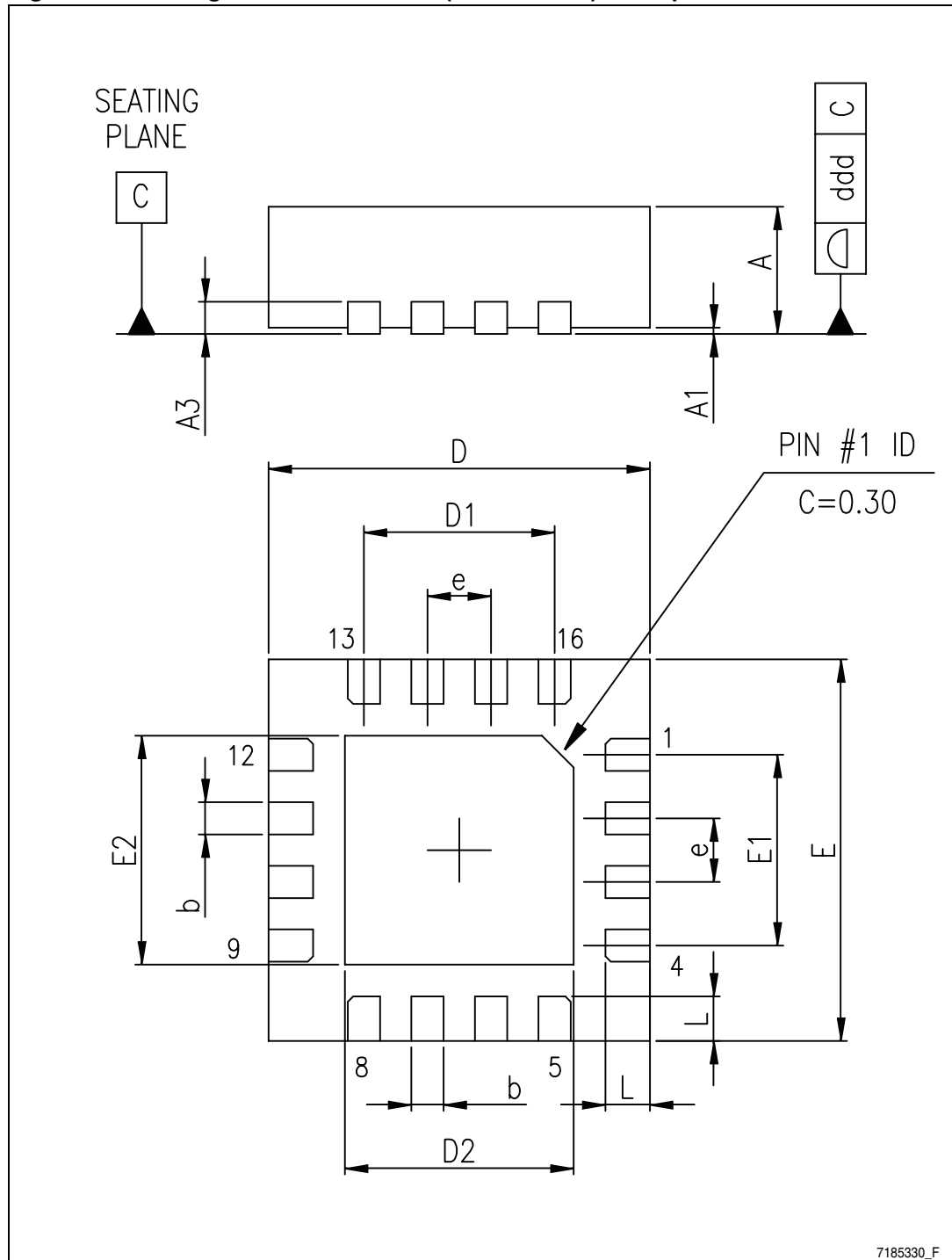

7185330_F

1. Drawing not to scale.

Table 26. Package mechanical data for QFN16 (3 x 3 x 1 mm) - 0.50 pitch

Symbol	Millimeters		
	Min	Typ	Max
A	0.80	0.90	1.00
A1	–	0.02	0.05
A3	–	0.20	–
b	0.18	0.25	0.30
D	2.85	3.00	3.15
D1	–	1.50	–
D2	See exposed pad variation		
E	2.85	3.00	3.15
E1	–	1.50	–
E2	See exposed pad variation		
e	0.45	0.50	0.55
L	0.30	0.40	0.50
ddd	–	–	0.05

Table 27. Exposed pad variation

Symbol	Millimeters		
	Min	Typ	Max
D2	1.70	1.80	1.90
E2	1.70	1.80	1.90

Figure 13. Recommended footprint

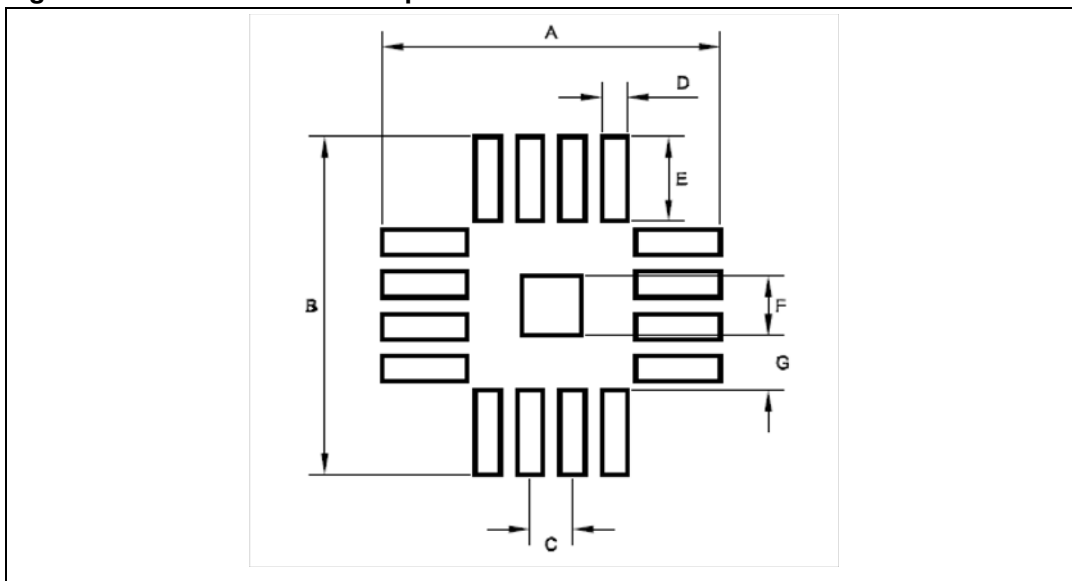

1. Drawing not to scale.

Table 28. Footprint dimensions

Symbol	Millimeters		
	Min	Typ	Max
A	–	3.8	–
B	–	3.8	–
C	–	0.5	–
D	–	0.3	–
E	–	0.8	–
F	–	1.5	–
G	–	0.35	–

Figure 14. Carrier tape for QFN16 (3 x 3 x 1 mm) - 0.50 pitch

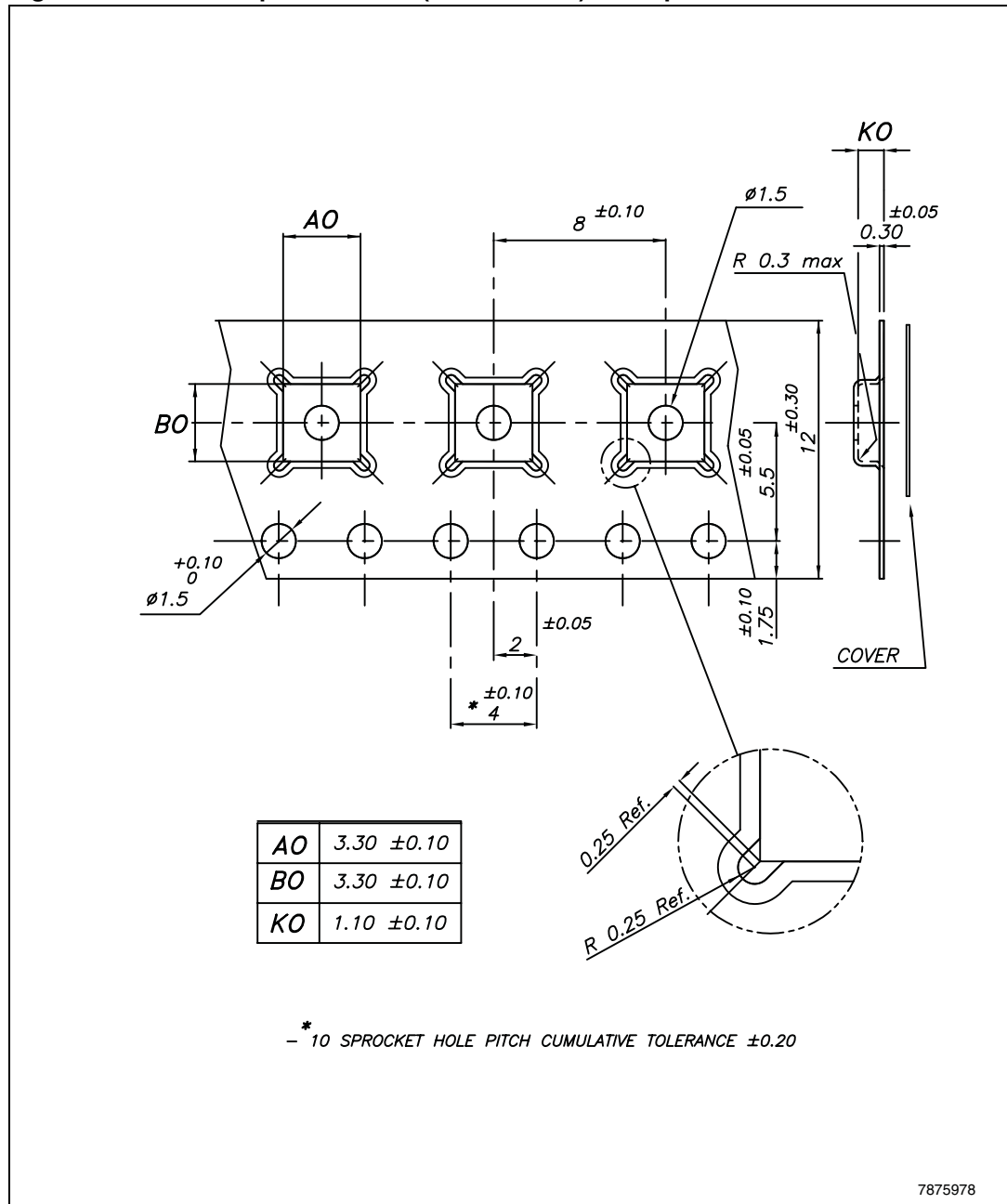

1. Drawing not to scale.

Figure 15. Reel information for QFN16 (3 x 3 x 1 mm) - 0.50 pitch

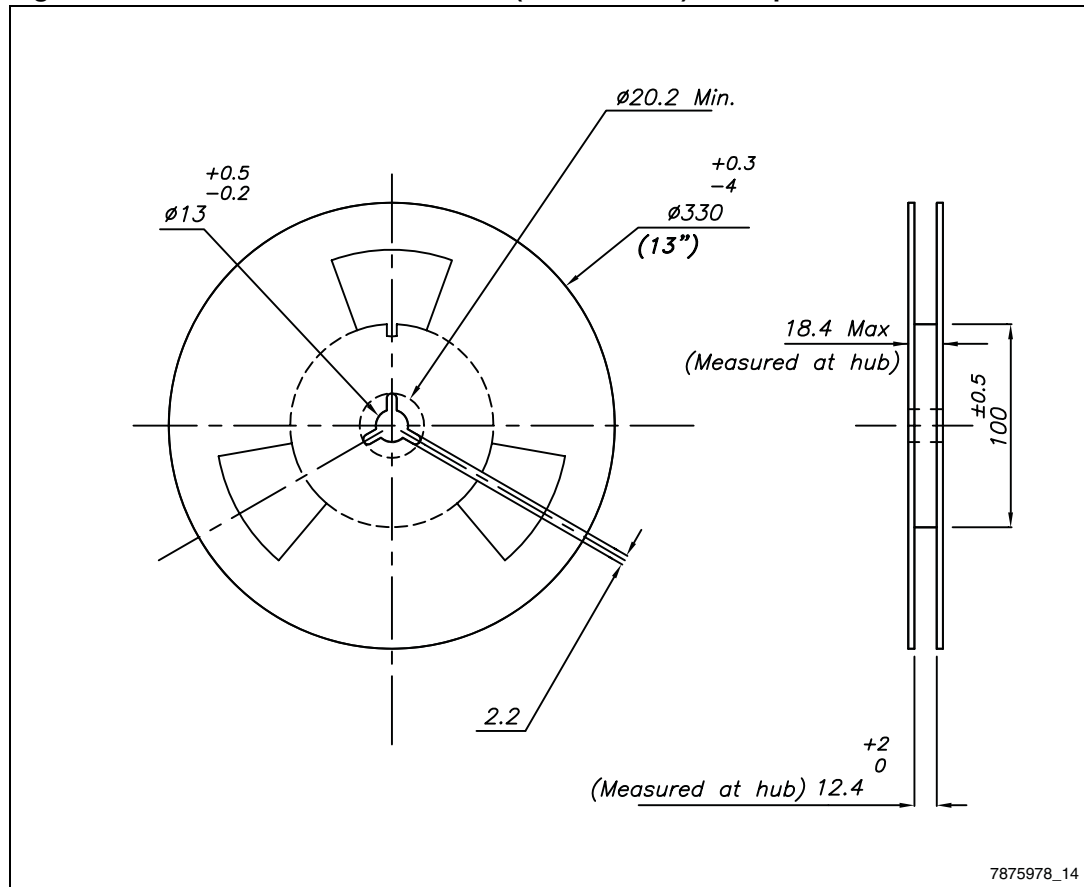

1. Drawing not to scale.

17 Revision history

Table 29. Document revision history

Date	Revision	Changes
09-Jun-2008	1	Initial release.
22-Apr-2009	2	Document status promoted from preliminary data to datasheet. Modified: title and package silhouette in the cover page. <i>Section 6: STMPE811 registers, Section 7: System and identification registers, Section 10: Touchscreen controller and Section 13: GPIO controller:</i> content reworked to improve readability, no technical changes. Updated: <i>Figure 6, Table 3, Section 14: Maximum rating and Section 16: Package mechanical data.</i>
22-Sep-2010	3	Modified: <i>Table 11: Register summary map table</i> and information related to the TSC_DATA_X register.

Please Read Carefully:

Information in this document is provided solely in connection with ST products. STMicroelectronics NV and its subsidiaries ("ST") reserve the right to make changes, corrections, modifications or improvements, to this document, and the products and services described herein at any time, without notice.

All ST products are sold pursuant to ST's terms and conditions of sale.

Purchasers are solely responsible for the choice, selection and use of the ST products and services described herein, and ST assumes no liability whatsoever relating to the choice, selection or use of the ST products and services described herein.

No license, express or implied, by estoppel or otherwise, to any intellectual property rights is granted under this document. If any part of this document refers to any third party products or services it shall not be deemed a license grant by ST for the use of such third party products or services, or any intellectual property contained therein or considered as a warranty covering the use in any manner whatsoever of such third party products or services or any intellectual property contained therein.

UNLESS OTHERWISE SET FORTH IN ST'S TERMS AND CONDITIONS OF SALE ST DISCLAIMS ANY EXPRESS OR IMPLIED WARRANTY WITH RESPECT TO THE USE AND/OR SALE OF ST PRODUCTS INCLUDING WITHOUT LIMITATION IMPLIED WARRANTIES OF MERCHANTABILITY, FITNESS FOR A PARTICULAR PURPOSE (AND THEIR EQUIVALENTS UNDER THE LAWS OF ANY JURISDICTION), OR INFRINGEMENT OF ANY PATENT, COPYRIGHT OR OTHER INTELLECTUAL PROPERTY RIGHT.

UNLESS EXPRESSLY APPROVED IN WRITING BY AN AUTHORIZED ST REPRESENTATIVE, ST PRODUCTS ARE NOT RECOMMENDED, AUTHORIZED OR WARRANTED FOR USE IN MILITARY, AIR CRAFT, SPACE, LIFE SAVING, OR LIFE SUSTAINING APPLICATIONS, NOR IN PRODUCTS OR SYSTEMS WHERE FAILURE OR MALFUNCTION MAY RESULT IN PERSONAL INJURY, DEATH, OR SEVERE PROPERTY OR ENVIRONMENTAL DAMAGE. ST PRODUCTS WHICH ARE NOT SPECIFIED AS "AUTOMOTIVE GRADE" MAY ONLY BE USED IN AUTOMOTIVE APPLICATIONS AT USER'S OWN RISK.

Resale of ST products with provisions different from the statements and/or technical features set forth in this document shall immediately void any warranty granted by ST for the ST product or service described herein and shall not create or extend in any manner whatsoever, any liability of ST.

ST and the ST logo are trademarks or registered trademarks of ST in various countries.

Information in this document supersedes and replaces all information previously supplied.

The ST logo is a registered trademark of STMicroelectronics. All other names are the property of their respective owners.

© 2010 STMicroelectronics - All rights reserved

STMicroelectronics group of companies

Australia - Belgium - Brazil - Canada - China - Czech Republic - Finland - France - Germany - Hong Kong - India - Israel - Italy - Japan - Malaysia - Malta - Morocco - Philippines - Singapore - Spain - Sweden - Switzerland - United Kingdom - United States of America

www.st.com