

EZ PCI Card 10/100

Fast Ethernet PCI Network Card

- ◆ Plug-and-play installation
- ◆ Remote LAN Wakeup support
- ◆ On-board socket for optional Boot ROM
- ◆ Auto-negotiation of speed and duplex mode
- ◆ Low power consumption
- ◆ ACPI and OnNow/ PC 98/99 compliant



EZ PCI Card 10/100

User Guide

From SMC's EZ line of low-cost workgroup LAN solutions

SMC[®]

Networks

6 Hughes

Irvine, CA 92618

Phone: (949) 707-2400

May 2001

Pub. # 150734-102

Copyright

Information furnished by SMC Networks, Inc. (SMC) is believed to be accurate and reliable. However, no responsibility is assumed by SMC for its use, nor for any infringements of patents or other rights of third parties which may result from its use. No license is granted by implication or otherwise under any patent or patent rights of SMC. SMC reserves the right to change specifications at any time without notice.

Copyright © 2001 by
SMC Networks, Inc.
6 Hughes, Irvine, CA.
All rights reserved. Printed in Taiwan

Trademarks:

SMC is a registered trademark; and EZ PCI Card is a trademark of SMC Networks, Inc. Other product and company names are trademarks or registered trademarks of their respective holders.

Limited Warranty

Limited Warranty Statement: SMC Networks, Inc. (“SMC”) warrants its products to be free from defects in workmanship and materials, under normal use and service, for the applicable warranty term. All SMC products carry a standard 90-day limited warranty from the date of purchase from SMC or its Authorized Reseller. SMC may, at its own discretion, repair or replace any product not operating as warranted with a similar or functionally equivalent product, during the applicable warranty term. SMC will endeavor to repair or replace any product returned under warranty within 30 days of receipt of the product.

The standard limited warranty can be upgraded to a Limited Lifetime* warranty by registering new products within 30 days of purchase from SMC or its Authorized Reseller. Registration can be accomplished via the enclosed product registration card or online via the SMC web site. Failure to register will not affect the standard limited warranty. The Limited Lifetime warranty covers a product during the Life of that Product, which is defined as the period of time during which the product is an “Active” SMC product. A product is considered to be “Active” while it is listed on the current SMC price list. As new technologies emerge, older technologies become obsolete and SMC will, at its discretion, replace an older product in its product line with one that incorporates these newer technologies. At that point, the obsolete product is discontinued and is no longer an “Active” SMC product. A list of discontinued products with their respective dates of discontinuance can be found at http://www.smc.com/smc/pages_html/support.html.

All products that are replaced become the property of SMC. Replacement products may be either new or reconditioned. Any replaced or repaired product carries either a 30-day limited warranty or the remainder of the initial warranty, whichever is longer. SMC is not responsible for any custom software or firmware, configuration information, or memory data of Customer contained in, stored on, or integrated with any products returned to SMC pursuant to any warranty. Products returned to SMC should have any customer-installed accessory or add-on components, such as expansion modules, removed prior to returning the product for replacement. SMC is not responsible for these items if they are returned with the product.

Customers must contact SMC for a Return Material Authorization number prior to returning any product to SMC. Proof of purchase may be required. Any product returned to SMC without a valid Return Material Authorization (RMA) number clearly marked on the outside of the package will be returned to customer at customer’s expense. For warranty claims within North America, please call our toll-free customer support number at (800) 762-4968. Customers are responsible for all shipping charges from their facility to SMC. SMC is responsible for return shipping charges from SMC to customer.

WARRANTIES EXCLUSIVE: IF AN SMC PRODUCT DOES NOT OPERATE AS WARRANTED ABOVE, CUSTOMER’S SOLE REMEDY SHALL BE REPAIR OR REPLACEMENT OF THE PRODUCT IN QUESTION, AT SMC’S OPTION. THE FOREGOING WARRANTIES AND REMEDIES ARE EXCLUSIVE AND ARE IN LIEU

LIMITED WARRANTY

OF ALL OTHER WARRANTIES OR CONDITIONS, EXPRESS OR IMPLIED, EITHER IN FACT OR BY OPERATION OF LAW, STATUTORY OR OTHERWISE, INCLUDING WARRANTIES OR CONDITIONS OF MERCHANTABILITY AND FITNESS FOR A PARTICULAR PURPOSE. SMC NEITHER ASSUMES NOR AUTHORIZES ANY OTHER PERSON TO ASSUME FOR IT ANY OTHER LIABILITY IN CONNECTION WITH THE SALE, INSTALLATION, MAINTENANCE OR USE OF ITS PRODUCTS. SMC SHALL NOT BE LIABLE UNDER THIS WARRANTY IF ITS TESTING AND EXAMINATION DISCLOSE THE ALLEGED DEFECT IN THE PRODUCT DOES NOT EXIST OR WAS CAUSED BY CUSTOMER'S OR ANY THIRD PERSON'S MISUSE, NEGLIGENCE, IMPROPER INSTALLATION OR TESTING, UNAUTHORIZED ATTEMPTS TO REPAIR, OR ANY OTHER CAUSE BEYOND THE RANGE OF THE INTENDED USE, OR BY ACCIDENT, FIRE, LIGHTNING, OR OTHER HAZARD.

LIMITATION OF LIABILITY: IN NO EVENT, WHETHER BASED IN CONTRACT OR TORT (INCLUDING NEGLIGENCE), SHALL SMC BE LIABLE FOR INCIDENTAL, CONSEQUENTIAL, INDIRECT, SPECIAL, OR PUNITIVE DAMAGES OF ANY KIND, OR FOR LOSS OF REVENUE, LOSS OF BUSINESS, OR OTHER FINANCIAL LOSS ARISING OUT OF OR IN CONNECTION WITH THE SALE, INSTALLATION, MAINTENANCE, USE, PERFORMANCE, FAILURE, OR INTERRUPTION OF ITS PRODUCTS, EVEN IF SMC OR ITS AUTHORIZED RESELLER HAS BEEN ADVISED OF THE POSSIBILITY OF SUCH DAMAGES.

SOME STATES DO NOT ALLOW THE EXCLUSION OF IMPLIED WARRANTIES OR THE LIMITATION OF INCIDENTAL OR CONSEQUENTIAL DAMAGES FOR CONSUMER PRODUCTS, SO THE ABOVE LIMITATIONS AND EXCLUSIONS MAY NOT APPLY TO YOU. THIS WARRANTY GIVES YOU SPECIFIC LEGAL RIGHTS, WHICH MAY VARY FROM STATE TO STATE. NOTHING IN THIS WARRANTY SHALL BE TAKEN TO AFFECT YOUR STATUTORY RIGHTS.

* SMC will provide warranty service for one year following discontinuance from the active SMC price list. Under the limited lifetime warranty, internal and external power supplies, fans, and cables are covered by a standard one-year warranty from date of purchase.

SMC Networks, Inc.
6 Hughes
Irvine, CA 92618

COMPLIANCES

FCC - Class B

This equipment has been tested and found to comply with the limits for a Class B digital device, pursuant to Part 15 of the FCC Rules. These limits are designed to provide reasonable protection against harmful interference in a residential installation. This equipment generates, uses and can radiate radio frequency energy and, if not installed and used in accordance with instructions, may cause harmful interference to radio communications. However, there is no guarantee that the interference will not occur in a particular installation. If this equipment does cause harmful interference to radio or television reception, which can be determined by turning the equipment off and on, the user is encouraged to try to correct the interference by one or more of the following measures:

- Reorient the receiving antenna
- Increase the separation between the equipment and receiver
- Connect the equipment into an outlet on a circuit different from that to which the receiver is connected
- Consult the dealer or an experienced radio/TV technician for help

EMC Conformance Declaration - Class B

SMC contact for these products in Europe is:

SMC Networks Europe,
Edificio Conata II,
Calle Fructuós Gelabert 6-8, 2^a, 4^a,
08970 - Sant Joan Despí,
Barcelona, Spain.

This information technology equipment complies with the requirements of the Low Voltage Directive 73/23/EEC and the EMC Directive 89/336/EEC, and carries the CE Mark accordingly. It conforms to the following specifications:

EMC: EN55024 (1998)/CISPR-22 (1995) Class B

IEC 61000-4-2 (1995)	4 kV CD, 8 kV AD
IEC 61000-4-3 (1995)	3 V/m
IEC 61000-4-4 (1995)	1.0 kV - (power line) 0.5 kV - (signal line)
IEC 61000-4-5 (1995)	2 kV - (line to line) 1 kV - (line to ground)
IEC 61000-4-6 (1995)	3 Vrms
IEC 61000-4-11 (1995)	Voltage dip >95% - 10 ms 30% - 500 ms 60% - 100 ms
	Voltage interruption >95% - 5000 ms

Industry Canada - Class B

This digital apparatus does not exceed the Class B limits for radio noise emissions from digital apparatus as set out in the interference-causing equipment standard entitled “Digital Apparatus”, ICES-003 of Industry Canada.

Cet appareil numérique respecte les limites de bruits radioélectriques applicables aux appareils numériques de Classe B prescrites dans la norme sur le matériel brouilleur: “Appareils Numériques”, NMB-003 édictée par l’Industrie.

VCCI Class B Compliance (Japan)

この装置は、情報処理装置等電波障害自主規制協議会（VCCI）の基準に基づくクラスB情報技術装置です。この装置は、家庭環境で使用することを目的としていますが、この装置がラジオやテレビジョン受信機に近接して使用されると受信障害を引き起こすことがあります。

取り扱い説明書に従って正しい取り扱いをして下さい。

TABLE OF CONTENTS

About the EZ PCI Card 10/100	1
Features and Benefits	2
Hardware Description	3
LED Indicators	4
Remote LAN Wakeup	5
Installing the Card	6
Equipment Checklist	6
Instructions	7
Testing Program	9
Troubleshooting	10
PCI Compatibility	10
Solutions for Common Problems	12
Network Card Installation Problems	12
Network Connection Problems	13
Cable Specifications	14
Cable Types and Specifications	14
Twisted-Pair Cable and Pin Assignments	14
Specifications	16

TABLE OF CONTENTS

ABOUT THE EZ PCI CARD 10/100

SMC's EZ PCI Card 10/100 is a dual-speed Fast Ethernet card for PCI local bus-compliant computers. A true plug-and-play device, this card is auto-configurable upon power up and also supports auto-negotiation to automatically select the optimum speed and communication mode of an attached device. This EZ PCI Card 10/100 complies with ACPI and OnNow PC98/ PC99 and also supports Remote LAN Wakeup. By connecting the EZ PCI Card 10/100 card's Wake-On-LAN (WOL) cable, a WOL-enabled computer can be managed remotely. Software can be loaded and updated, configurations changed, data backed up and inventory checked, all from a central location. See "Remote LAN Wakeup" on page 5 for more information.

Features and Benefits

- ◆ Compatible with IEEE 802.3 Ethernet and IEEE 802.3u Fast Ethernet standards
- ◆ Full- and half-duplex support for both 10 Mbps and 100 Mbps speeds
- ◆ Auto-negotiation selects 10/100 Mbps and full/half duplex automatically
- ◆ Supports full-duplex operation for up to 200 Mbps of bandwidth
- ◆ Automatic configuration set up using the PCI computer's BIOS setup program
- ◆ Supports Remote LAN Wakeup for efficient centralized desktop management
- ◆ Supports optional boot ROM for remote booting of a management PC's operating system
- ◆ ACPI and OnNow/PC98/99 compliance reduces power consumption

Hardware Description

The EZ PCI Card 10/100 is equipped with:

- 1 RJ-45 connector for 10/100 Mbps connections
- 1 3-pin connector for Wake-On-LAN cable
- 1 Socket for optional boot ROM
- 1 LED indicator

The components of the EZ PCI Card 10/100 are shown in the figure below:

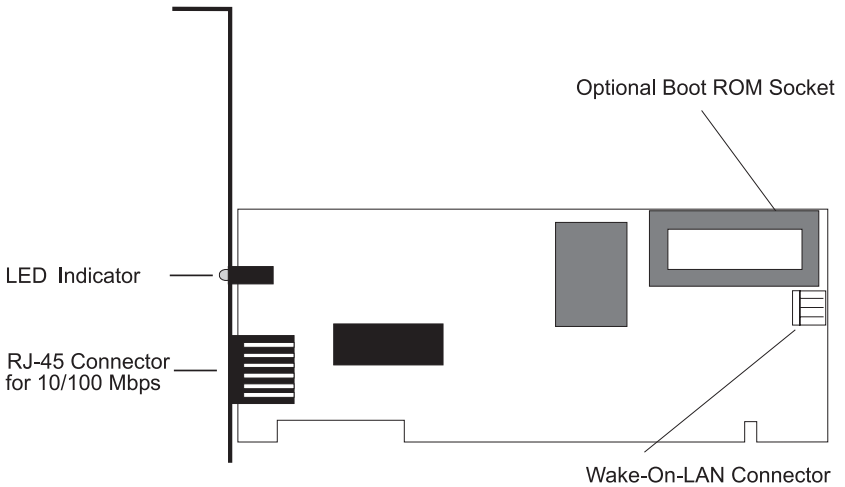

LED Indicators

The SMC1255TX includes one status LED indicator, as described in the following figure and table.

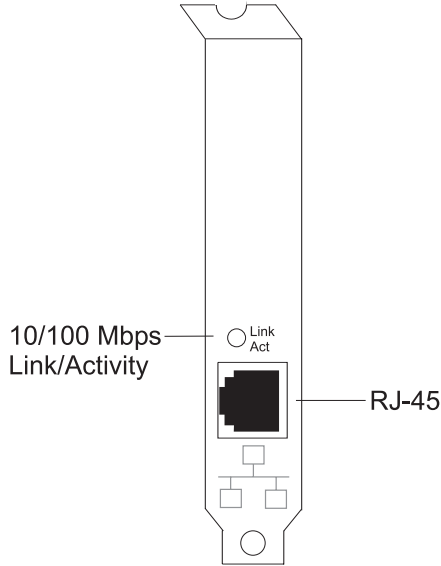

Status	Description
On Amber	Indicates a valid 10BASE-T link
Flashing Amber	Indicates 10 Mbps network activity
On Green	Indicates a valid 100BASE-TX link
Flashing Green	Indicates 100 Mbps network activity

Remote LAN Wakeup

Remote LAN Wakeup capability is a key feature of a centrally managed PC environment. This technology enables networked PCs to be “woken up” from a sleep or powered-off state so they can be managed from a central location, at any time of the day or night.

To employ Remote LAN Wakeup, three elements are required:

- Desktop management software that can send a “wake-up” packet to a PC.
- A Wake-On-LAN enabled PC motherboard that can supply low-level auxiliary power to a network card when the PC is powered off.
- A Wake-On-LAN network card that can recognize a wake-up packet and signal the PC to power up.

A Wake-On-LAN enabled PC is never completely powered off, it maintains a low-level auxiliary power supply to the motherboard. The 3-wire Wake-On-LAN cable provides one line for the network card auxiliary power and one line for the card wake-up signal, the other line is ground. Even if the PC is powered off the network card is always active and monitoring the network. When a wake-up packet is detected, the card signals the motherboard to power up the PC. With the PC powered on, maintenance and other support tasks can be performed.

INSTALLING THE CARD

Equipment Checklist

After unpacking the EZ PCI 10/100 card, check the contents of the box to be sure you have received the following components:

- EZ PCI 10/100 card SMC1255TX
- Wake-On-LAN cable
- SuperDisk™ network drivers diskette
- SMC Warranty Registration Card
- User Guide

Immediately inform your dealer in the event of any incorrect, missing or damaged parts. If possible, please retain the carton and original packing materials in case there is a need to return the product.

Please fill out and return the Warranty Registration Card to SMC or register on SMC's Web site. The EZ PCI Card 10/100 is covered by a limited lifetime warranty.

Instructions

Warnings:

- Network cards are sensitive to static electricity. To protect the card, avoid touching its electrical components and always touch the metal chassis of your computer before handling the card.
 - Back up your driver diskette and use the copy as the working diskette to protect the original from accidental damage.
1. Switch off the computer, unplug the power cord, and remove the computer's cover.
 2. Select an unused PCI bus-master slot and remove its protective bracket.
 3. Carefully insert the card and press until all the edge connectors are firmly seated inside the slot. Then screw the card's bracket securely into the PC's chassis.

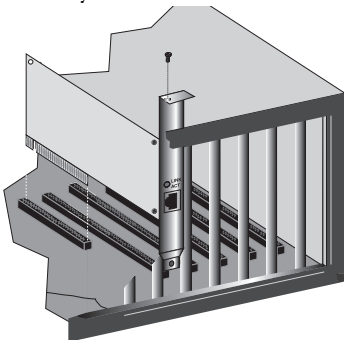

4. Attach the Wake-On-LAN cable (optional). If you require Wake-On-LAN capability from a powered-off state, attach one end of the 3-pin Wake-On-LAN cable to the connector on the top edge of the card, and the other end to the "5 V Standby" connector on the computer's motherboard. Refer to your computer's installation manual to locate this connector.

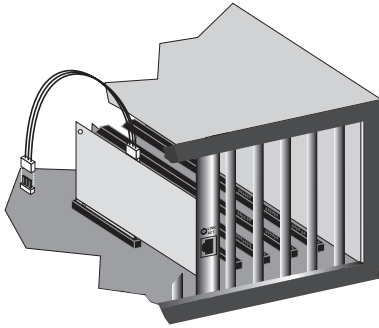

5. Connect the EZ PCI Card 10/100 directly to a 10BASE-T or 100BASE-TX hub or switch using UTP cable (Category 3, 4 or 5 for 10BASE-T; Category 5 for 100BASE-TX). The maximum allowable length of UTP cable connections is 100 meters (328 ft). When inserting an RJ-45 plug, be sure the tab on the plug clicks into position to ensure that it is properly seated.
6. Replace the computer's cover and power it on. The EZ PCI Card 10/100 should be automatically configured by the host computer's BIOS. However, if you have an older computer, you may have to manually configure the computer's BIOS settings. See "Troubleshooting" on page 10.
7. The SMC SuperDisk that accompanies the EZ PCI Card 10/100 contains all the network operating system drivers supported by this card. Please read the "RELEASE.TXT" file on the diskette for a list of all drivers. Also, a text file is included with each driver to detail the proper installation procedure. Any new or updated drivers can be downloaded from SMC's Web site (see the back cover of this guide).

Testing Program

If the EZ PCI Card 10/100 is not automatically configured by the host PC, or there is a problem with the card, run the DOS-based Testing Program to help view the PC's BIOS settings of this card. Boot the computer to a full DOS environment (not a DOS window) and run the Testing Program, SET1255.EXE, on the SMC SuperDisk. Should any of the diagnostic tests fail, reboot your computer and run the diagnostics again to see if the problem persists. If it does, record the failure indicated and contact SMC's Technical Support for assistance.

TROUBLESHOOTING

PCI Compatibility

Early PCI BIOS versions do not properly support the PCI specification and may “hang” when a network card driver tries to load. If this occurs, make sure your BIOS correctly supports the PCI Local Bus Specification (v2.0 or later) and upgrade your computer BIOS to the latest version.

Some PCI computers are not self-configuring and require you to perform some or all of the following functions by motherboard jumper changes and/or BIOS Setup program configuration:

- ◆ Verify that the PCI slot is an enabled bus-master slot and not a slave PCI slot. The EZ PCI Card 10/100 must be installed in a PCI bus-master slot. In some computers the PCI slot must be configured to enable bus mastering. Refer to your PC’s manual and check the PCI BIOS Setup program to be sure the PCI slot is an enabled busmaster slot.
- ◆ In some computers, you may be required to disable Plug-and-Play in the BIOS Setup program if resources are not properly assigned between the network card and other installed cards.
- ◆ Some computers may require you to reserve interrupts and memory addresses for installed ISA cards to prevent PCI cards from using the same settings. Refer to your PC’s manual and check the PCI BIOS Setup program configuration options for ISA cards.
- ◆ Make sure the PCI slot is configured to support INTA.

- ◆ Ensure that INTA for the slot is assigned to a free interrupt (IRQ) number.
- ◆ Check the BIOS Setup program's PCI parameters for the slot where the EZ PCI Card 10/100 network card is installed. Ensure that the slot is configured for level-triggered interrupts instead of edge-triggered interrupts. An example of typical PCI parameters follows:

```

PCI Slot #:           (slot number where the network card
                       is installed)

Master:              Enabled

Slave:              Enabled

Latency Timer:      40 (range is 20 to 255)

Interrupt Type:     Level-Triggered

Interrupt Number:   (choose any number the BIOS Setup
                       supplies that does not conflict with
                       another installed card)

```

Note that the wording of these parameters varies with different computers, and not all parameters may be configurable.

Always consult your computer manual for information on changing motherboard jumper settings and BIOS Setup program parameters for use with PCI network cards. If you set a motherboard jumper and modify the computer's BIOS Setup, make sure the jumper and BIOS settings match.

Solutions for Common Problems

Problems are often caused by cabling errors, conflicts with other devices installed in the same computer, or software that has been configured incorrectly. If you encounter a problem with the EZ PCI Card 10/100 network card, use the following checklists to identify and correct the problem.

Network Card Installation Problems

If your computer cannot find the EZ PCI Card 10/100, or the network driver does not install correctly, check the following items before contacting SMC Technical Support.

- ◆ Make sure the card is securely seated in the PCI slot. Check for any hardware problems, such as physical damage to the card's edge connector.
- ◆ Try the card in another PCI bus-master slot. If this fails, test with another EZ PCI Card 10/100 card that is known to operate correctly.
- ◆ Check for resource conflict in the PCI configuration. See section "PCI Compatibility" in this chapter.
- ◆ Make sure your computer is using the latest BIOS available.
- ◆ If there are other network cards in the computer, they may be causing conflict. Remove all other cards from the computer and test the EZ PCI Card 10/100 separately.
- ◆ Check for a defective computer or PCI bus by trying the network card in another computer that is known to operate correctly.

Network Connection Problems

There may be a network connection problem if the LED on the card's bracket does not light, or if you cannot access any network resources from the computer. Check the following items before contacting SMC Technical Support.

- ◆ Be sure you are using Category 5 cable for 100 Mbps connections, and that the length of any cable does not exceed 100 m (328 ft).
- ◆ Inspect all network cables and connections. Make sure the network cable is securely attached to the card's connector.
- ◆ Make sure the correct network card driver is installed for your operating system. If necessary, try reinstalling the driver.
- ◆ Make sure the computer and other network devices are receiving power. If you suspect a power outlet to be faulty, plug another device into it to verify that it is working.
- ◆ If the the network card's speed or duplex mode has been configured manually, check that it matches that of the attached network device port. Note that it is recommended to set the card to auto-negotiation when installing the network driver.
- ◆ The port on the network device that the card is attached to may be defective. Try using another port on the device.
- ◆ If you cannot access a Windows or NetWare service on the network, check that you have enabled and configured the service correctly. If you cannot connect to a particular server, ensure that you have access rights and a valid ID and password.
- ◆ If you cannot access the Internet, be sure you have configured your system for TCP/IP.

CABLE SPECIFICATIONS

Cable Types and Specifications

Cable Types and Specifications			
Cable	Type	Max. Length	Connector
10BASE-T	Cat. 3, 4, 5 100-ohm UTP	100 m (328 ft)	RJ-45
100BASE-TX	Cat. 5 100-ohm UTP	100 m (328 ft)	RJ-45

Twisted-Pair Cable and Pin Assignments

DO NOT plug a phone jack connector into any RJ-45 port. Use only twisted-pair cables with RJ-45 connectors that conform with FCC standards.

For 10BASE-T/100BASE-TX connections, a twisted-pair cable must have two pairs of wires. Each wire pair is identified by two different colors. For example, one wire might be red and the other red with white stripes. Also, an RJ-45 connector must be attached to both ends of the cable.

Caution: Each wire pair must be attached to the RJ-45 connectors in a specific orientation.

The figure below illustrates how the pins on the RJ-45 connector are numbered. Be sure to hold the connectors in the same orientation when attaching the wires to the pins.

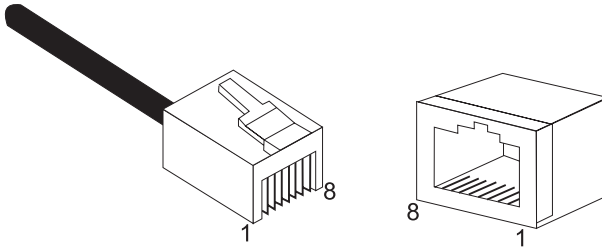

With 10BASE-T/100BASE-TX cable, pins 1 and 2 are used for transmitting data, and pins 3 and 6 for receiving data. The “+” and “-” signs in the tables below are used to represent the polarity of the wires that make up each wire pair.

RJ-45 Pin Assignments	
Pin	Assignment*
1	Tx+
2	Tx-
3	Rx+
6	Rx-

SPECIFICATIONS

Ports

1 RJ-45 for 10BASE-T and 100BASE-TX

Host Interface

PCI Bus compliant to PCI spec. 2.2.

LED

Link, Speed, Activity

Data Bus Access

32-bit bus mastering

Size (without bracket)

119.92 x 42.98 mm (4.72 x 1.69 in.)

Weight

47 g (1.66 oz)

Power Requirements

5 VDC, 125 mA (typical)

Temperature

Operating: 0 to 55 °C (32 to 131 °F)

Storage: -20 to 65 °C (-4 to 149 °F)

Humidity

10% to 90% non-condensing

Standards

IEEE 802.3 10BASE-T

IEEE 802.3u 100BASE-TX

IEEE 802.3x 100BASE-TX Flow Control support

IEEE 802.1p/Q Quality of Service (QoS)

PCI bus V 2.2, ACPI

OnNow/PC 98, PC 99

DMI 2.0, Wired for Management 2.0

Compliances

FCC Class B
VCCI Class B
CE Mark
CISPR 22 Class B

Warranty

Limited lifetime

NetWare ODI Drivers

Novell NetWare 3.1X to 5.x
Netware Lan WorkPlace
Novell DOS Client
Novell Lan Analyzer
Server 3.1x to 5.x

Unix Drivers

Linux
FreeBSB
SCO Unix 5.0x
SCO Unixware 7.x

NDIS Drivers

Windows 95 OSR2
Windows 98
Windows 2000
Windows ME
Windows NT 3.51, 4.0
Microsoft Lan Manager
IBM LAN Server
IBM LAN Support
DEC PATHWORKS
Windows for Workgroups 3.11

SPECIFICATIONS

Packet Drivers

FTP PC/TCP

NCSA TCP/IP

FOR TECHNICAL SUPPORT, CALL:

From U.S.A. and Canada (24 hours, 7 days a week)
(800) SMC-4-YOU; (949) 707-2400; (949) 707-2460 (Fax)
From Europe (8:00 AM - 5:30 PM UK Greenwich Mean Time)
44 (0) 1188 748740; 44 (0) 1189 748741 (Fax)

INTERNET

E-mail address:
techsupport@smc.com
european.techsupport@smc-europe.com
Driver updates:
<http://www.smc.com/support.html>
World Wide Web:
<http://www.smc.com/>
FTP Site:
ftp.smc.com

FOR LITERATURE OR ADVERTISING RESPONSE, CALL:

U.S.A. and Canada:	(800) SMC-4-YOU;	Fax (949) 707-2460
Spain:	34-93-477-4920;	Fax 34-93-477-3774
UK:	44 (0) 1188 748700;	Fax 44 (0) 1189 748701
Southern Europe:	33 (1) 41.18.68.68;	Fax 33 (1) 41.18.68.69
Central/Eastern Europe:	49 (0) 89 92861-200;	Fax 49 (0) 89 92861-230
Nordic:	46 (8) 564 33145;	Fax 46 (8) 87 62 62
Middle East:	971-48818410;	Fax 971-48817993
South Africa:	27 (0) 11-3936491;	Fax 27 (0) 11-3936491
PRC:	86-10-6235-4958;	Fax 86-10-6235-4962
Taiwan:	886-2-2747-4780;	Fax 886-2-2747-9220
Asia Pacific:	(65) 238 6556;	Fax (65) 238 6466
Korea:	82-2-553-0860;	Fax 82-2-553-7202
Japan:	81-45-224-2332;	Fax 81-45-224-2331
Australia:	61-2-9416-0437;	Fax 61-2-9416-0474
India:	91-22-8204437;	Fax 91-22-8204443

SMC[®]

Networks

6 Hughes

Irvine, CA 92618

Model Numbers:
SMC1255TX, SMC1255TX/LP

SMC[®]
Networks
6 Hughes
Irvine, CA 92618

Publication Number: 150734-102 E052001-R01

