

2.5A high-side driver industrial intelligent power switch

Features

- 2.5A output current
- 9.5V to 35V supply voltage range
- Internal current limiting
- Thermal shutdown
- Open ground protection
- Internal negative voltage clamping to $V_S - 50V$ for fast demagnetization
- Differential inputs with large common mode range and threshold hysteresis
- Undervoltage lockout with hysteresis
- Open load detection
- Two diagnostic outputs
- Output status led driver
- Non dissipative short circuit protection
- Protection against and surge transient (IEC 61000-4-5)
- Immunity against burst transient (IEC 61000-4-4)
- ESD protection (human body model $\pm 2kV$)

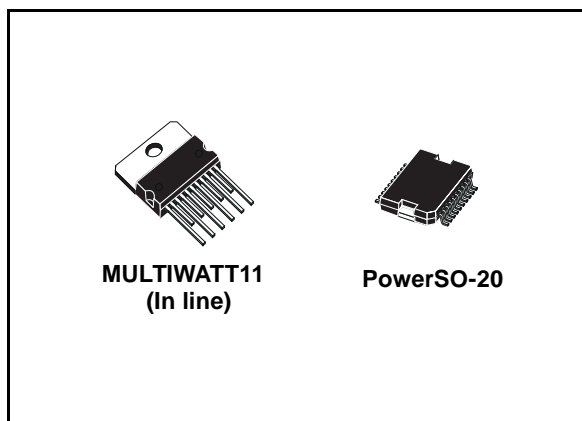

Description

The L6370 is a monolithic Intelligent Power Switch in Multipower BCD Technology, for driving inductive or resistive loads. An internal Clamping Diode enables the fast demagnetization of inductive loads. Diagnostic for CPU feedback and extensive use of electrical protections make this device extremely rugged and specially suitable for industrial automation applications..

Order codes

Part number	Op. Temp. range, °C	Package	Packing
L6370L	-25 to +85	MULTIWATT11	Tube
L6370D	-25 to +85	PowerSO-20	Tube
L6370D013TR	-25 to +85	PowerSO-20	Tape & Reel

Contents

1	Block diagram and pin description	3
1.1	Pin description	4
2	Electrical specifications	5
2.1	Absolute maximum ratings	5
2.2	Thermal data	5
2.3	Electrical characteristics	6
2.4	AC operation	8
3	Circuit description	9
3.1	Diagnostic truth table	10
3.2	Input section	10
3.3	Diagnostic logic	10
3.4	Short circuit operation	11
3.5	Overtemperature protection (OVT)	11
3.6	Undervoltage protection (UV)	11
3.7	Demagnetization of inductive loads	12
4	Package mechanical data	13
4.1	Multiwatt11 (in-line) mechanical data & package dimensions	14
4.2	PowerSO-20 mechanical data & package dimensions	15
4.3	PowerSO-20 packing information	16
5	Revision history	19

1 Block diagram and pin description

Figure 1. Block diagram

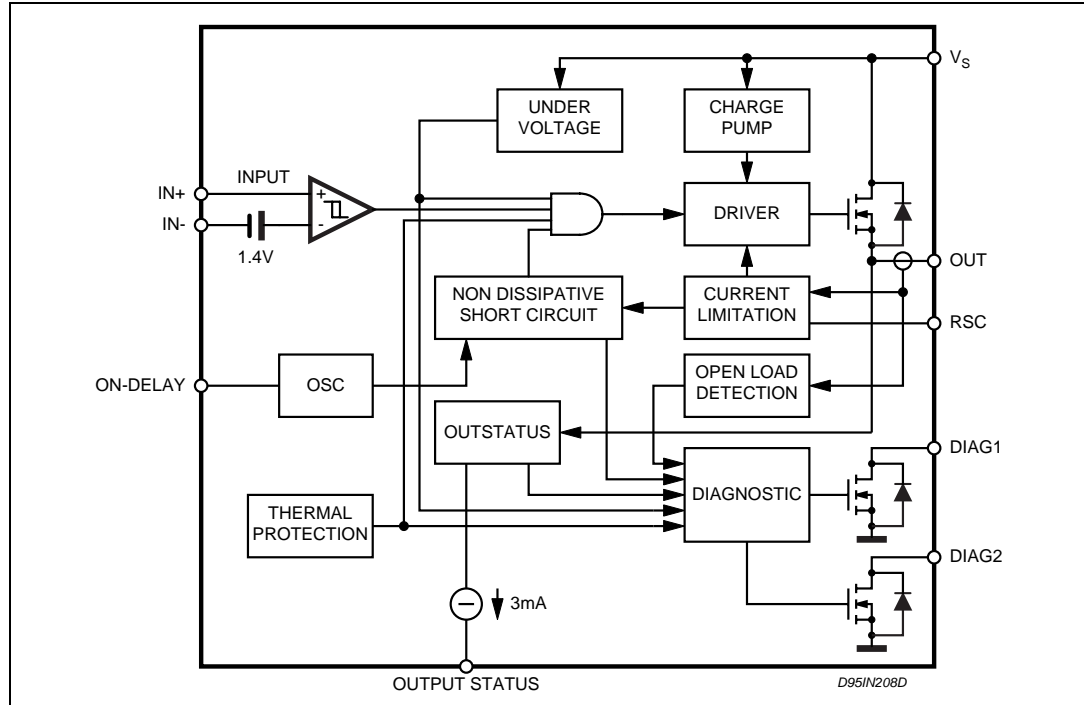
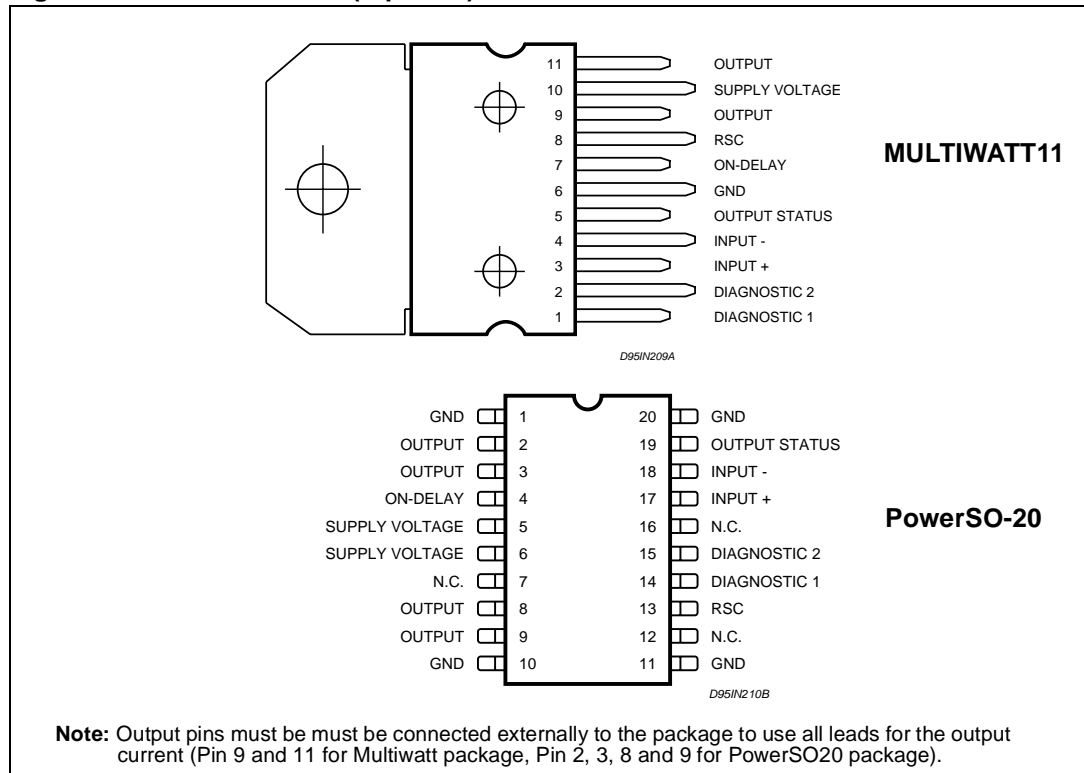

Figure 2. Pin connection (top view)



1.1 Pin description

Table 1. Pin description (pin numbering referred to MULTIWATT package)

Pin N°	Pin name	Function
1	DIAG1	DIAGNOSTIC 1 output. This open drain reports the IC working conditions. (See Diagnostic truth Table 6)
2	DIAG2	DIAGNOSTIC 2 output. This open drain reports the IC working conditions. (See Diagnostic truth Table 6)
3	IN-	Comparator non inverting input
4	IN+	Comparator inverting input
5	OUTSTATUS	This current source output is capable of driving a LED to signal the status of the output pin. The pin is active (source current) when the output pin is considered high (See Figure 3)
6	GND	Ground
7	ON-DELAY	Programmable ON time interval duration during short circuit operation
8	RSC	Current limitation setting.
9	OUTPUT	High Side output with built-in current limitation
10	V _S	Supply Voltage Input, the value of the supply voltage is monitored to detect under voltage condition
11	OUTPUT	High Side output with built-in current limitation

2 Electrical specifications

2.1 Absolute maximum ratings

**Table 2. Absolute maximum ratings
(Pin numbering referred to MULTIWATT package)**

Symbol	Parameter	Value	Unit
V_S	Supply Voltage (Pin 10) ($T_W < 10\text{ms}$)	50	V
$V_S - V_O$	Supply to Output Differential Voltage. See also V_{CI} (Pins 10 - 9)	internally limited	V
V_{od}	Externally Forced Voltage (Pin7)	-0.3 to 7	V
I_{od}	Externally Forced Voltage (Pin7)	+1	mA
V_i	Input Voltage (Pins 3/4)	-10 to V_S+10	V
V_i	Differential Input Voltage (Pins 3 - 4)	43	V
I_i	Input Current (Pins 3/4)	20	mA
I_O	Output Current (Pin 9). See also ISC (Pin 9)	internally limited	A
P_{TOT}	Power Dissipation. See also Thermal Characteristics.	internally limited	W
T_{OP}	Operating Temperature Range (T_{amb})	-25 to +85	°C
T_{STG}	Storage Temperature	-55 to 150	°C
E_I	Energy Induct. Load $T_J = 85^\circ\text{C}$	1	J

2.2 Thermal data

Table 3. Thermal data

Symbol	Description		MULTIWATT11	PowerSO-20	Unit
R_{thJC}	Thermal Resistance Junction to case	Max.	1.5	1.5	°C/W
R_{thJA}	Thermal Resistance Junction to ambient	Max.	35	-	

2.3 Electrical characteristics

Table 4. Electrical characteristics
($V_S = 24V$; $T_J = -25$ to $+125^\circ C$, unless otherwise specified)

Symbol	Parameter	Test condition	Min.	Typ.	Max.	Unit
V_{smin}	Supply Voltage for Valid Diagnostics	$I_{diag} > 0.5mA$; $V_{dg1} = 1.5V$	4		35	V
V_s	Supply Voltage (operative)		9.5	24	35	V
I_q	Quiescent Current $I_{out} = I_{os} = 0$	V_{ii} V_{ih}		0.8 3	1.4 4	mA
V_{sth1}	Undervoltage Threshold 1	(See <i>Figure 3</i>), $T_{amb} = 0$ to $+85^\circ C$	8.5	9	9.5	V
V_{sth2}	Undervoltage Threshold 2		8	8.5	9	V
V_{sth3}	Supply Voltage Hysteresis		300	500	700	mV
I_{sc}	Short Circuit Current	$V_S = 9.5$ to $35V$; $R_L = 2\Omega$ $5k\Omega < R_{SC} < 30k\Omega$	15/ $R_{SC}(k\Omega)$			A
		$0 < R_{SC} < 5k\Omega$	2.6	3.2	4	A
V_{don}	Output Voltage Drop	$I_{out} = 2.0A$ $T_j = 25^\circ C$		200	280	mV
		$I_{out} = 2.5A$ $T_j = 25^\circ C$		320	440	mV
		$I_{out} = 2.5A$ $T_j = 25^\circ C$		250	350	mV
		$I_{out} = 2.5A$ $T_j = 25^\circ C$		400	550	mV
I_{oslk}	Output Leakage Current	$V_i = V_{ii}$; $V_o = 0V$			500	μA
V_{ol}	Low State Out Voltage	$V_i = V_{ii}$; $R_L = \infty$		0.8	1.5	V
V_{cl}	Internal Voltage Clamp ($V_S - V_o$)	$I_o = 1A$ Single Pulsed: $T_p = 300\mu s$	48	53	58	V
I_{old}	Open Load Detection Current	$V_i = V_{ih}$; $T_{amb} = 0$ to $+85^\circ C$	1	3	6	mA
V_{id}	Common Mode Input Voltage Range (Operative)	$V_S = 18$ to $35V$	-7		15	V
I_{ib}	Input Bias Current	$V_i = -7$ to $15V$; $-In = 0V$	-250		250	μA
V_{ith}	Input Threshold Voltage	$V + In > V - In$	0.8	1.4	2	V
V_{iths}	Input Threshold Hysteresis Voltage	$V + In > V - In$	50		400	mV
R_{id}	Diff. Input Resistance	$0 < +In < +16V$; $-In = 0V$ $-7 < +In < 0V$; $-In = 0V$		400 150		$k\Omega$
I_{ilk}	Input Offset Current	$V + In = V - In$ +li	-20		+20	μA
		$0V < V_i < 5.5V$ -li	-75	-25		
		$-In = GND$ +li		+10	+50	
		$0V < V + In < 5.5V$ -li	-250	-125		
		$+In = GND$ +li	-100	-30		
		$0V < V - In < 5.5V$ -li	-50	-15		

Table 4. Electrical characteristics (continued)
 ($V_S = 24V$; $T_J = -25$ to $+125^\circ C$, unless otherwise specified)

Symbol	Parameter	Test condition	Min.	Typ.	Max.	Unit
V_{oth1}	Output Status Threshold 1 Voltage	(See Figure 3)	4.5	5	5.5	V
V_{oth2}	Output Status Threshold 2 Voltage		4	4.5	5.0	V
V_{ohys}	Output Status Threshold Hysteresis		300	500	700	mV
I_{osd}	Output Status Source Current	$V_{out} > V_{oth1}$; $V_{os} = 2.5V$	2		4	mA
V_{osd}	Active Output Status Driver Drop Voltage	$V_S - V_{os}$; $I_{os} = 2mA$ $T_{amb} = 0$ to $+85^\circ C$		1.5	3	V
I_{oslk}	Output Status Driver Leakage Current	$V_{out} < V_{oth2}$; $V_{os} = 0V$ $V_S = 9.5$ to $35V$			25	μA
V_{dgl}	Diagnostic Drop Voltage	D1 / D2 = L ; $I_{diag} = 0.5mA$ D1 / D2 = L ; $I_{diag} = 3mA$		40 250		mV
I_{dglk}	Diagnostic Leakage Current	D1 / D2 = H ; $0 < V_{dg} < V_S$ $V_S = 9.5$ to $35V$			5	μA
Source drain NDMOS diode						
V_{fSD}	Forward On Voltage	@ $I_{fSD} = 2.5A$		1	1.5	V
I_{fp}	Forward Peak Current	$t = 10ms$; $d = 20\%$			6	A
t_{rr}	Reverse Recovery Time	$I_f = 2.5A$ $di/dt = 25A/\mu s$		200		ns
t_{fr}	Forward Recovery Time			100		ns
Thermal characteristics						
Θ_{Lim}	Junction Temp. Protect.		135	150		$^\circ C$
Θ_{TH}	Thermal Hysteresis			20		$^\circ C$

Note: $V_{il} \leq 0.8V$, $V_{ih} \geq 2V$ @ ($V+In > V-In$)

2.4 AC operation

Table 5. AC operation
(pin numbering referred to MULTIWATT package)

Symbol	Pin	Parameter	Test condition	Min.	Typ.	Max.	Unit
$t_r - t_f$	9 vs 4	Rise or Fall Time	$V_S = 24V$; $R_I = 70\Omega$; R_I to ground		20		μs
t_d	9 vs 3	Delay Time			5		μs
dV/dt	9, 11	Slew Rate (Rise and Fall Edge)		0.7	1	1.5	V/ μs
t_{ON}	7	On time during Short Circuit Condition	$50pF < C_{DON} < 2nF$		1.28		$\mu s/pF$
t_{OFF}		Of time during hort Circuit Condition			64		t_{ON}
f_{max}		Maximum Operating Frequency			25		KHz

3 Circuit description

Figure 3. Output status hysteresis

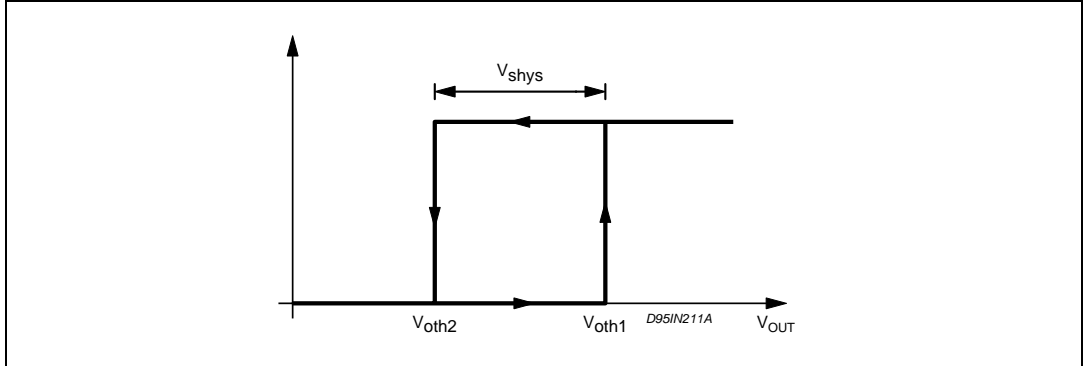

Figure 4. Undervoltage comparator hysteresis

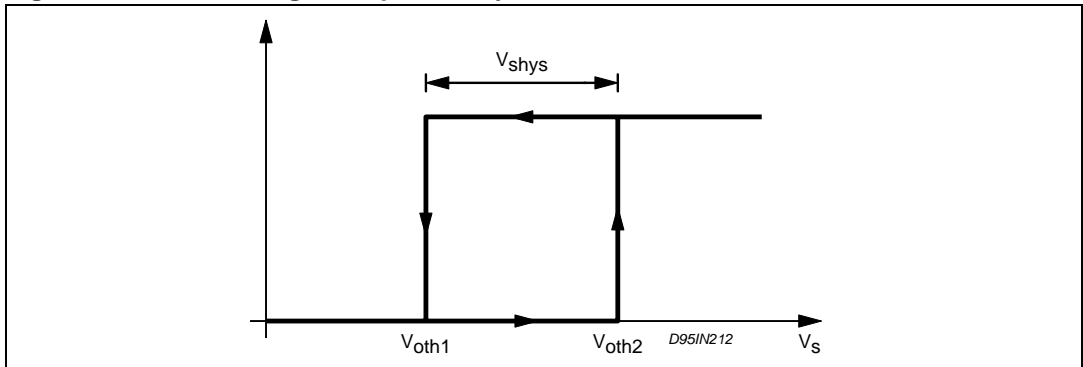
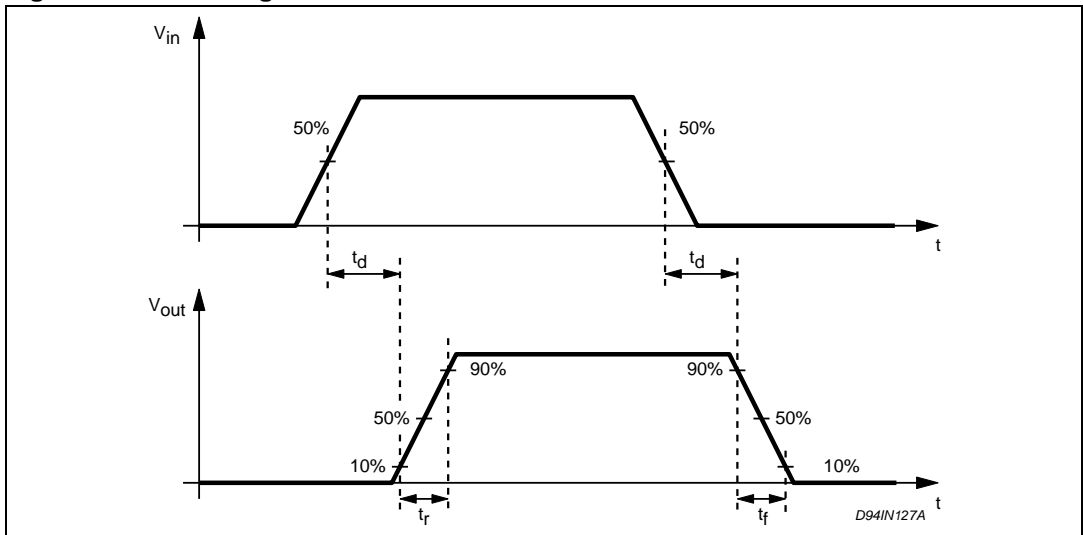

Figure 5. Switching waveforms



3.1 Diagnostic truth table

Table 6. Diagnostic truth table

Diagnostic conditions	Input	Output	Diag1	Diag2
Normal Operation	L	L	H	H
	H	H	H	H
Open Load Condition ($I_o < I_{old}$)	L	L	H	H
	H	H	L	H
Short to V_S	L	H	L	H
	H	H	L	H
Short Circuit to Ground ($I_O = I_{SC}$) (**) (pin ON-DELAY grounded)	H	H (*)	H	H
		L	H	H
Output DMOS Open	L	L	H	H
	H	L	L	H
Overtemperature	L	L	H	L
	H	L	H	L
Supply Undervoltage ($V_S < V_{sth2}$)	L	L	L	L
	H	L	L	L

Note:

(*) According to the intervention of the current limiting block.

(**) A cold lamp filament, or a capacitive load may activate the current limiting circuit of the IPS, when the IPS is initially turned on.

3.2 Input section

The input section is an high impedance differential stage with high common and differential mode range. There's built-in offset of +1.4V (typical value) and an hysteresis of 400mV (maximum value), to ensure high noise immunity.

3.3 Diagnostic logic

The operating conditions of the device are permanently monitored and the following occurrences are signalled via the DIAG1/DIAG2 open-drain output pins:

- Short Circuit versus ground. A current limiting circuit fixes at $I_{SC} = 3.2A$ (typical value) the maximum current that can be sourced from the OUTPUT pin (for more details see short circuit operation section).
- Short Circuit versus V_S .
- Under Voltage(UV)
- Over Temperature (OVT)
- Open Load, if the output current is less than 3mA (typical value).
- Output DMOS Open according to the diagnostic Truth [Table 6](#)

3.4 Short circuit operation

In order to minimise the power dissipation when the output is shorted to grounded, an innovative, non dissipative short circuit protection (patent pending) is implemented, avoiding, thus the intervention of the thermal protection in most cases.

Whenever the output is shorted to ground, or, generally speaking, an over current is sinked by the load, the output devices is driven in linear mode, sourcing the I_{sc} current (typically 3.2A) for a time interval (t_{on}) defined by means of the external C_{ON} capacitor connected between the ONDELAY pin and GND. Whether the short circuit crease within the t_{on} interval the DIAG2 output status is not affected, acting as a Programmable Diagnostic Delay.

This function allow the device to drive a capacitive load or a filament lamp (that exhibits a very low resistance during the initial heading phase) without the intervention of the diagnostic. If the short circuit lasts for the whole t_{ON} interval, the output DMOS is switched OFF and the DIAG2 goes low, for a time interval t_{OFF} lasting 64 times t_{ON} .

At the end of the t_{OFF} interval if the short circuit condition is still present, the output DMOS is turned ON (and the DIAG2 goes high - see [Figure 7](#)) for another t_{ON} interval and the sequence starts again, or, whether not, the normal condition operation is resumed.

The t_{ON} interval can be set to lasts between 64ms and 2.56ms for a C_{ON} capacitor value ranging between 50pF and 2nF to have:

$$t_{ON} (\mu s) = 1.28 C_{ON} (pF)$$

If the ON-DELAY pin is grounded the non dissipative short circuit protection is disabled, and the I_{sc} current is delivered until the Overtemperature Protection shuts the device off. The behaviour of the DIAG2 output is, in this situation, showed in the Diagnostic Truth [Table 6](#).

3.5 Overtemperature protection (OVT)

If the chip temperature exceeds Q_{lim} (measured in a central position in the chip) the chip deactivates itself.

The following actions are taken:

all the output stage is switched off;

the signal DIAG2 is activated (active low).

Normal operation is resumed as soon as (typically after some seconds) the chip temperature monitored goes back below $\Theta_{lim}-\Theta_H$.

The different thresholds with hysteretic behavior assure that no intermittent conditions can be generated.

3.6 Undervoltage protection (UV)

The supply voltage is expected to range from 9.5V to 35V, even if its reference value is considered to be 24V.

In this range the device operates correctly. Below 9.5V the overall system has to be considered not reliable.

Protection will thus shut off the output whenever the supply voltage falls below the mask fixed by the V_{sth1} (9V typ.) and V_{sth2} (8.5V typ.).

The hysteresis (see [Figure 4](#)) ensures a non intermittent behavior at low supply voltage with a superimposed ripple. The Under Voltage status is signalled via the DIAG1 and DIAG2 outputs (see the Diagnostic Truth [Table 6](#)).

3.7 Demagnetization of inductive loads

An internal zener diode, limiting the voltage across the Power MOS to between 50 and 60V (V_{ci}), provides safe and fast demagnetization of inductive loads without external clamping devices. The maximum energy that can be absorbed from an inductive load is specified as 1J (at $T_j = 85^\circ\text{C}$) (see [Figure 4](#)).

Figure 6. L6370 short circuit operation waveforms

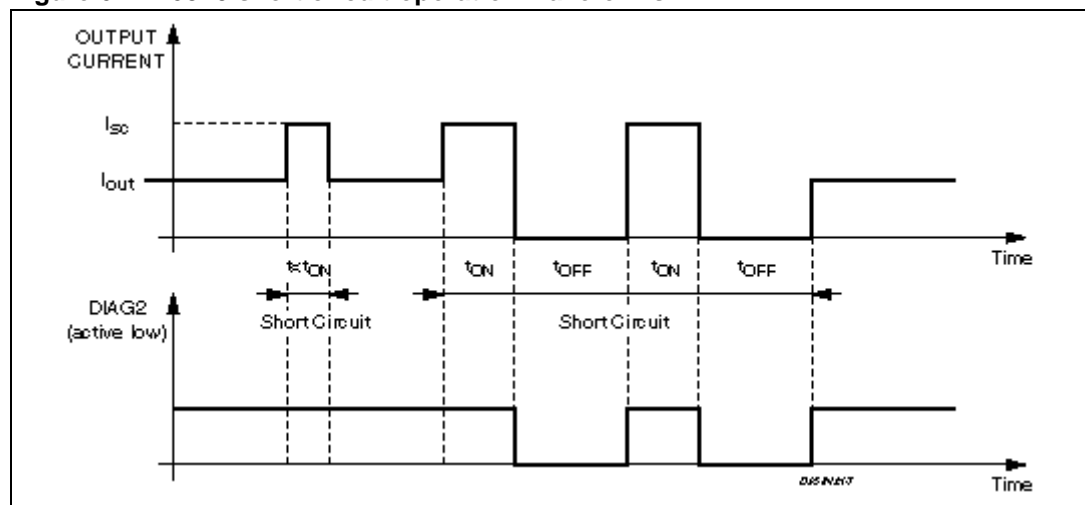
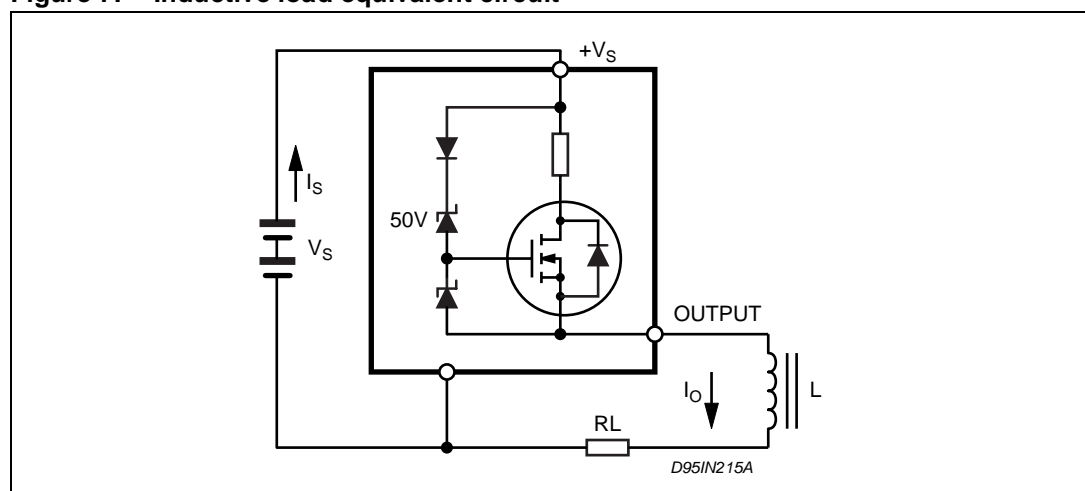

Figure 7. Inductive load equivalent circuit



4 Package mechanical data

In order to meet environmental requirements, ST offers these devices in ECOPACK® packages. These packages have a Lead-free second level interconnect . The category of second level interconnect is marked on the package and on the inner box label, in compliance with JEDEC Standard JESD97. The maximum ratings related to soldering conditions are also marked on the inner box label. ECOPACK is an ST trademark. ECOPACK specifications are available at: www.st.com

4.1 MULTIWATT11 (in-line) mechanical data & package dimensions

Figure 8. MULTIWATT11 (in-line) mechanical data & package dimensions

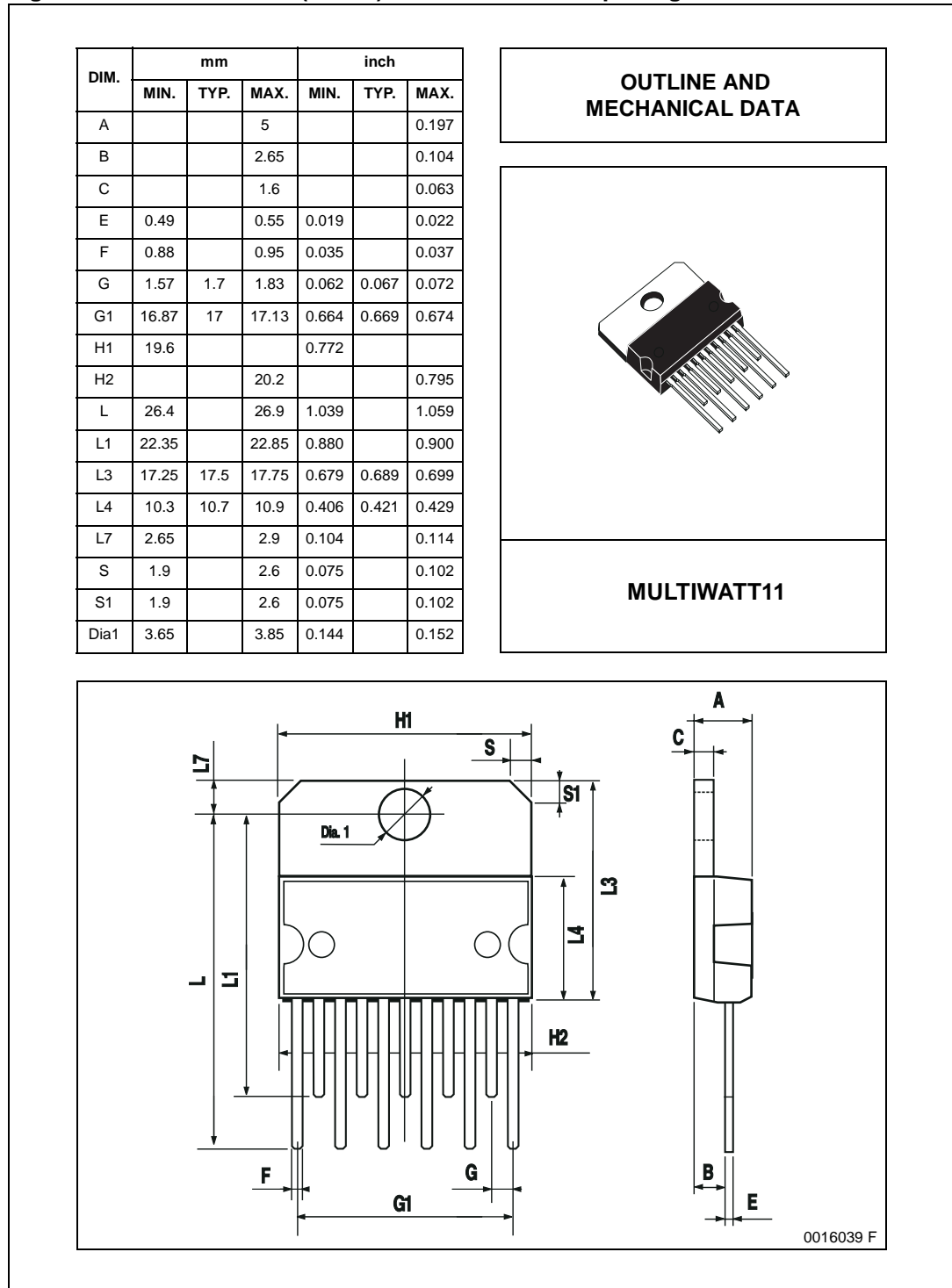

4.2 PowerSO-20 mechanical data & package dimensions

Figure 9. PowerSO-20 mechanical data & package dimensions

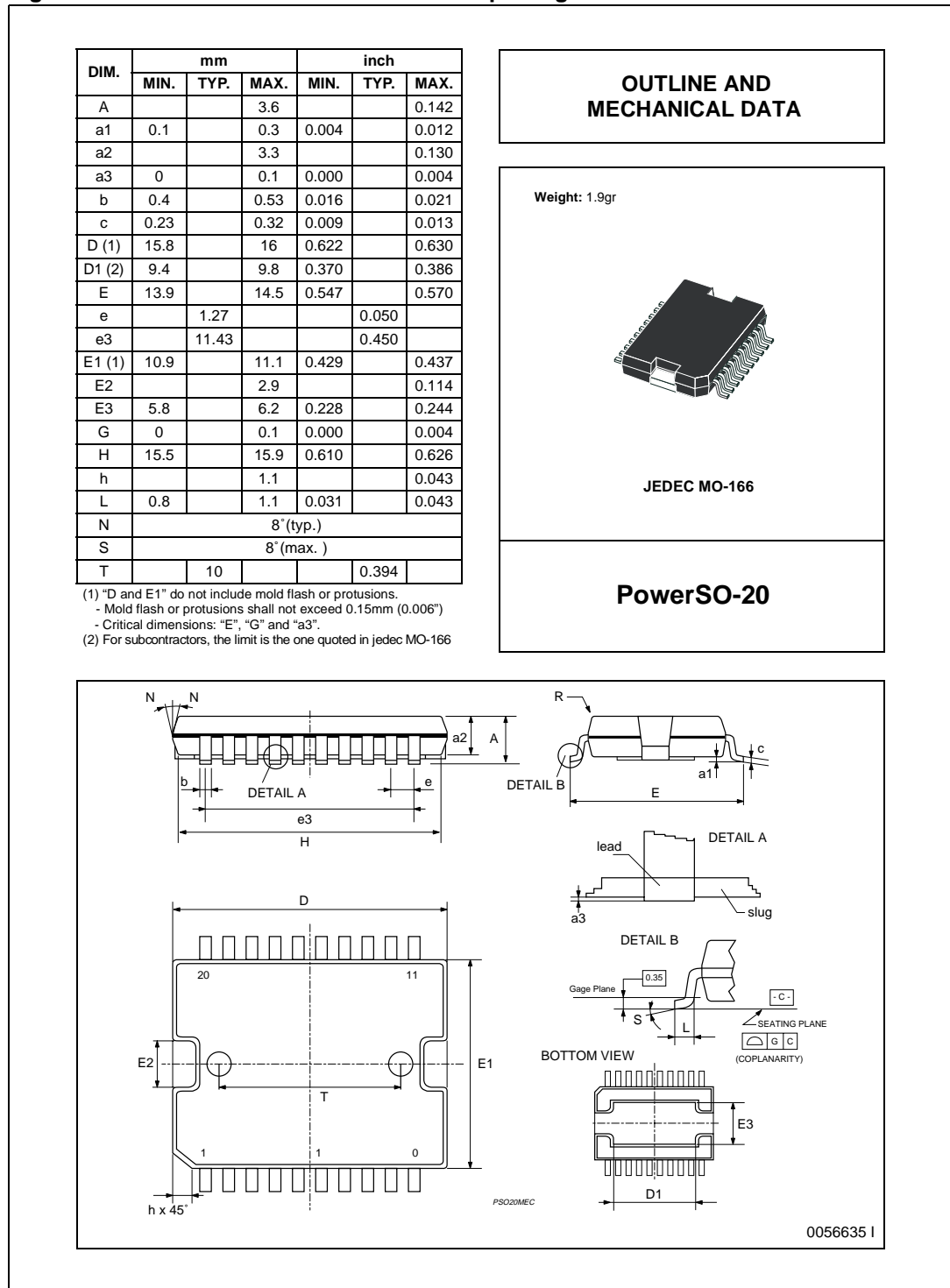

4.3 PowerSO-20 packing information

Figure 10. PowerSO-20 tube shipment information

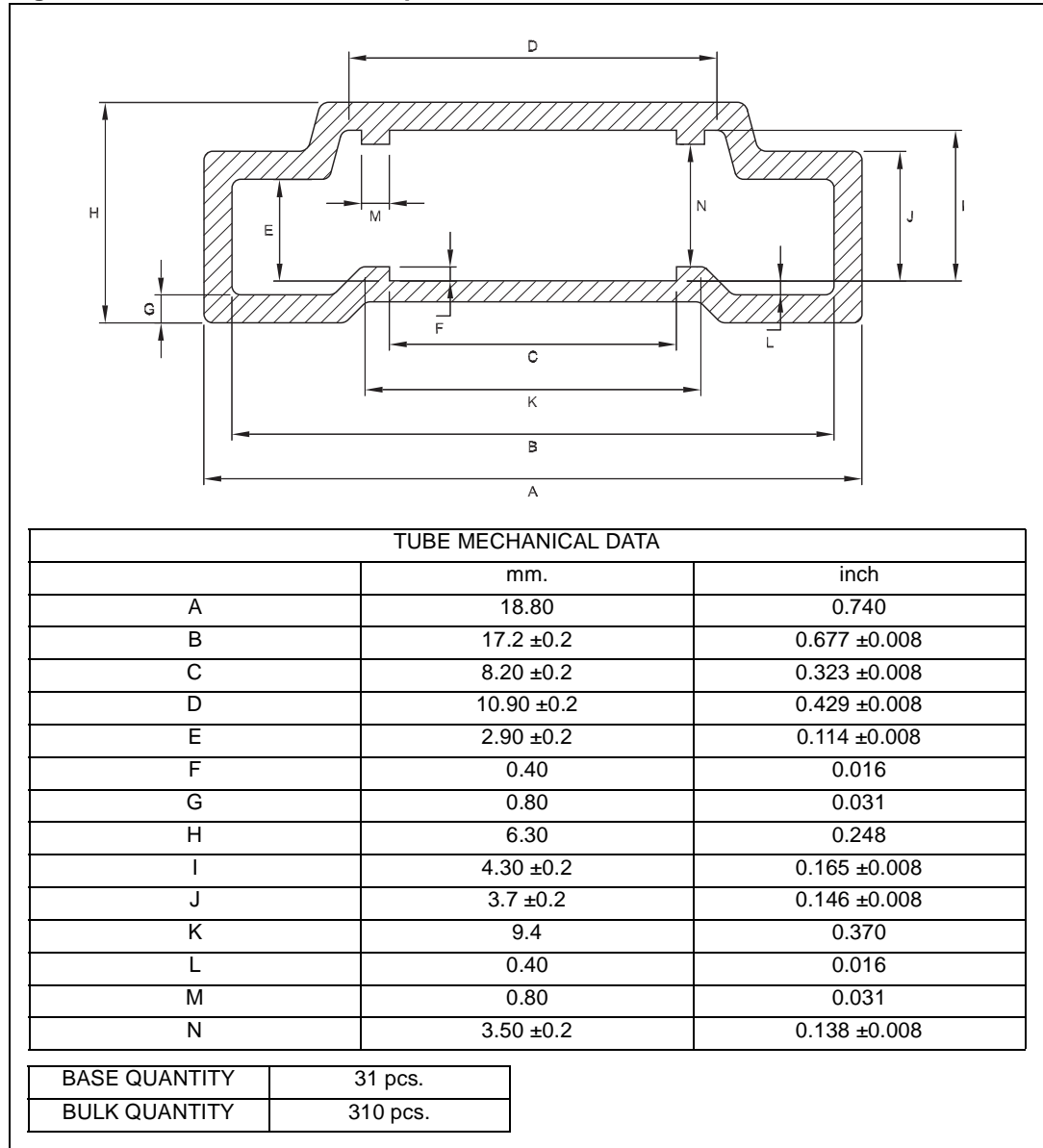

Figure 11. PowerSO-20 tape shipment specification

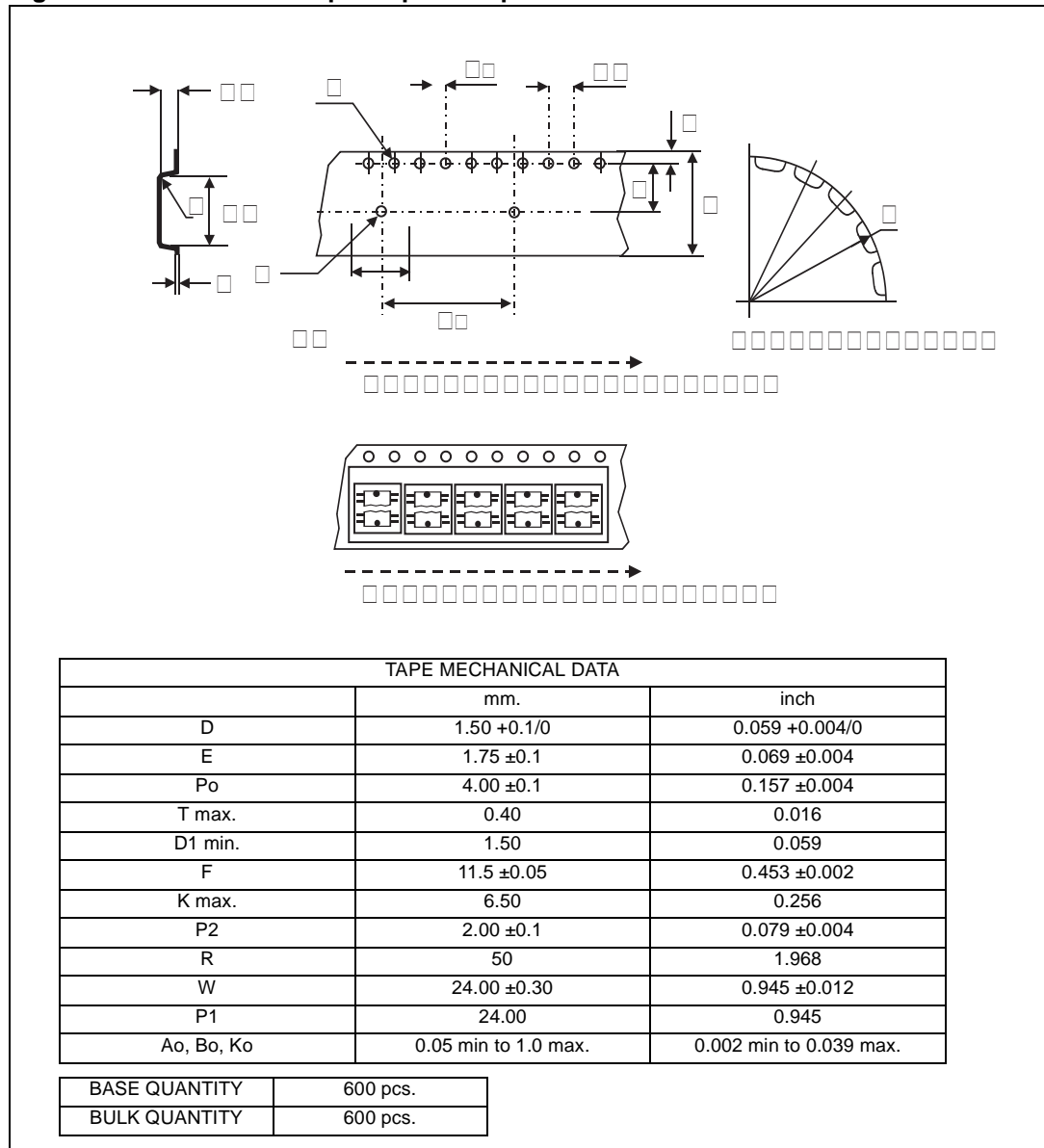

Figure 12. PowerSO-20 reel shipment specification

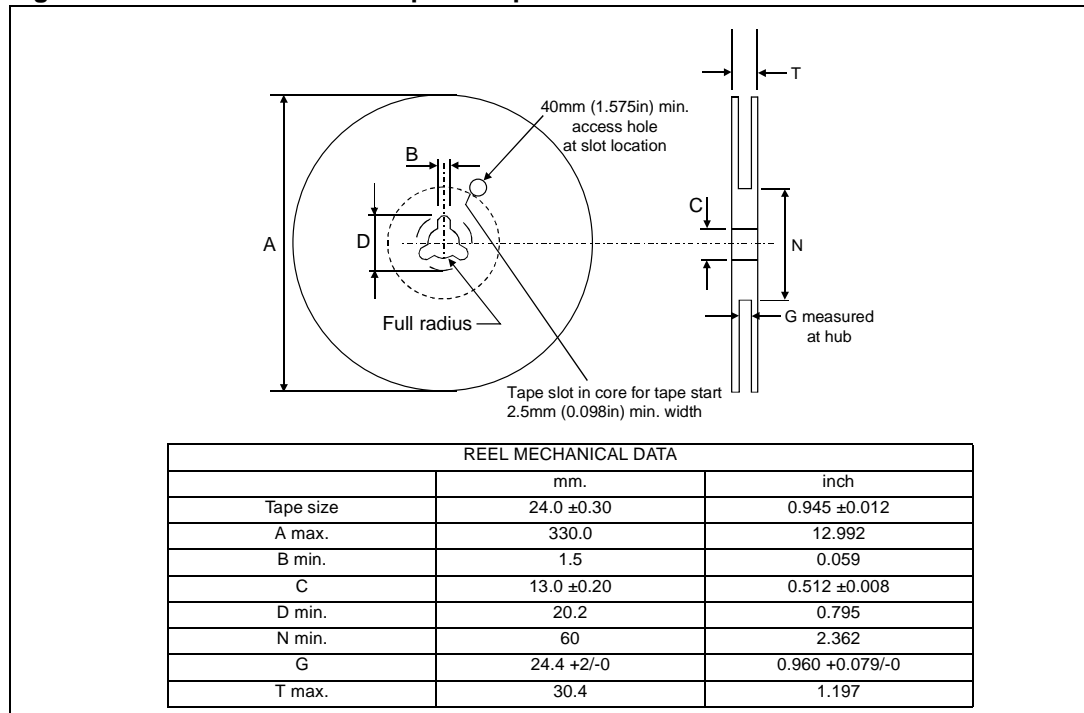
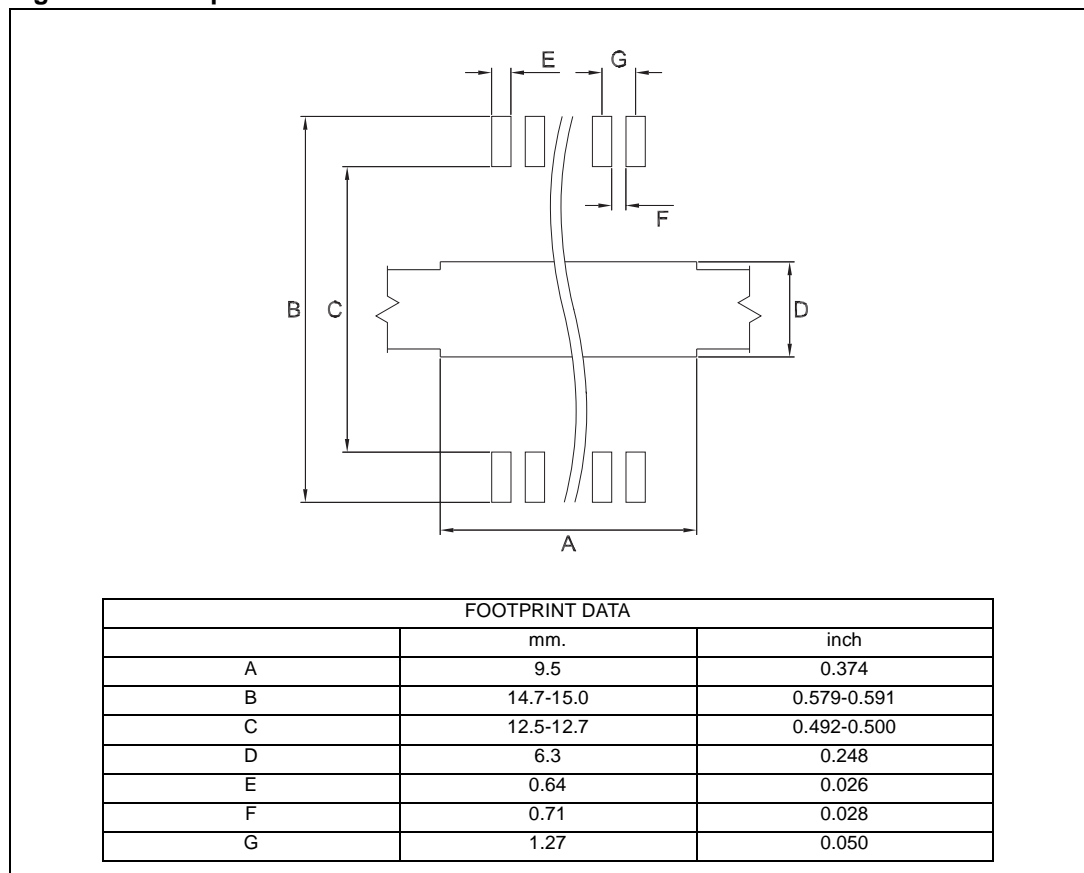

Figure 13. Footprint recommended data



5 Revision history

Table 7. Revision history

Date	Revision	Changes
10-Aug-2003	3	Initial release.
12-Dec-2005	4	Applied new Look & Feel Style Sheet. Added L6370D013TR part number. Updated Package and Packing section.
26-Apr-2006	5	Latest template

Please Read Carefully:

Information in this document is provided solely in connection with ST products. STMicroelectronics NV and its subsidiaries ("ST") reserve the right to make changes, corrections, modifications or improvements, to this document, and the products and services described herein at any time, without notice.

All ST products are sold pursuant to ST's terms and conditions of sale.

Purchasers are solely responsible for the choice, selection and use of the ST products and services described herein, and ST assumes no liability whatsoever relating to the choice, selection or use of the ST products and services described herein.

No license, express or implied, by estoppel or otherwise, to any intellectual property rights is granted under this document. If any part of this document refers to any third party products or services it shall not be deemed a license grant by ST for the use of such third party products or services, or any intellectual property contained therein or considered as a warranty covering the use in any manner whatsoever of such third party products or services or any intellectual property contained therein.

UNLESS OTHERWISE SET FORTH IN ST'S TERMS AND CONDITIONS OF SALE ST DISCLAIMS ANY EXPRESS OR IMPLIED WARRANTY WITH RESPECT TO THE USE AND/OR SALE OF ST PRODUCTS INCLUDING WITHOUT LIMITATION IMPLIED WARRANTIES OF MERCHANTABILITY, FITNESS FOR A PARTICULAR PURPOSE (AND THEIR EQUIVALENTS UNDER THE LAWS OF ANY JURISDICTION), OR INFRINGEMENT OF ANY PATENT, COPYRIGHT OR OTHER INTELLECTUAL PROPERTY RIGHT.

UNLESS EXPRESSLY APPROVED IN WRITING BY AN AUTHORIZED REPRESENTATIVE OF ST, ST PRODUCTS ARE NOT DESIGNED, AUTHORIZED OR WARRANTED FOR USE IN MILITARY, AIR CRAFT, SPACE, LIFE SAVING, OR LIFE SUSTAINING APPLICATIONS, NOR IN PRODUCTS OR SYSTEMS, WHERE FAILURE OR MALFUNCTION MAY RESULT IN PERSONAL INJURY, DEATH, OR SEVERE PROPERTY OR ENVIRONMENTAL DAMAGE.

Resale of ST products with provisions different from the statements and/or technical features set forth in this document shall immediately void any warranty granted by ST for the ST product or service described herein and shall not create or extend in any manner whatsoever, any liability of ST.

ST and the ST logo are trademarks or registered trademarks of ST in various countries.

Information in this document supersedes and replaces all information previously supplied.

The ST logo is a registered trademark of STMicroelectronics. All other names are the property of their respective owners.

© 2006 STMicroelectronics - All rights reserved

STMicroelectronics group of companies

Australia - Belgium - Brazil - Canada - China - Czech Republic - Finland - France - Germany - Hong Kong - India - Israel - Italy - Japan - Malaysia - Malta - Morocco - Singapore - Spain - Sweden - Switzerland - United Kingdom - United States of America

www.st.com