



Basin Spout Deck Mounted

RS Stock No. 195-9688

This spout is supplied with two types of flow outlet, a flow straightener which is factory fitted and an alternative aerator insert which is supplied loose in the box. The flow straightener should be used when the water pressure range is 0.1 bar to 1 bar. Above 1 bar it is recommended that the aerator is fitted. The aerator provides a splash free flow by mixing air with water.

To fit the aerator insert simply unscrew the flow casing from the spout, remove the plastic flow straightener, insert and replace with the aerator insert. Ensure that the rubber sealing washer is fitted into the outlet before replacing insert and casing.

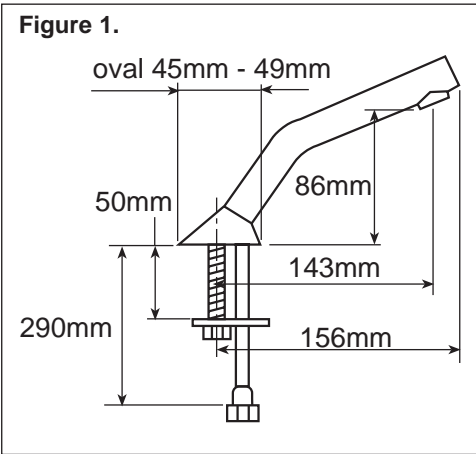

Installation

It is essential that the supply pipework is thoroughly flushed before connecting the terminal outlet otherwise flow straighteners or aerator inserts could become restricted by debris.

Basin spout deck mounted

- Fit spout to basin/worktop with 'O' ring under base flange above work surface and brass washer, clamping bar, and fixing nut below work surface in above order onto threaded stud.
- Tighten fixing nut firmly up to the clamping bar using a box spanner or the screwdriver slots provided. Ensure that the clamping plate does not foul or restrict the plastic inlet tube of the spout.
- Connect plastic inlet tube to supply pipework using the 1/2" coupling nut provided. **DO NOT SOLDER NEAR THE PLASTIC INLET TUBE AS THIS COULD CAUSE DAMAGE.**

To maintain the surface finish of these products simply wipe occasionally with a mild detergent on a soft damp cloth. Rinse thoroughly and dry using a soft dry cloth. Never use abrasive cleansers or chemical household cleaners. Avoid contact with concentrated bleach.

Technical specification

Materials	Outlet: Brass Inlet: Plastic tube
Projection	143mm from centre of spout to centre of outlet
Outlet type	Plastic flow straightener housed in brass casing fitted. Interchangeable anti-splash aerator supplied loose in box for use at pressures above 1 bar.
Connections	1/2" BSP female parallel thread
Surface finish	Chrome plate

Recommended operating pressures

Minimum - 0.2 bar (2 metres) static. Maximum - 6 bar

Flow rates litres/minutes	Dynamic pressures	0.1 bar	1 bar	5 bar
	Aerator	N/A	13.6	30.4
Flow straightener		9.0	28.5	63.6