

Empowered by Innovation

NEC

High-Performance Microcontrollers **V850 Series**

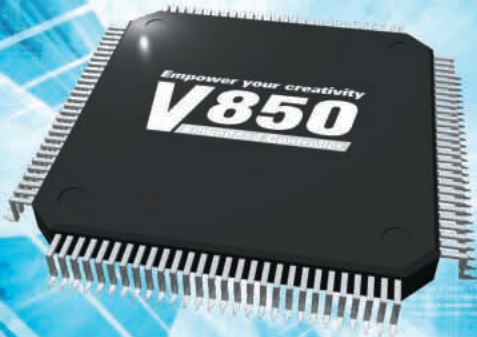

Empower your creativity
V850
Embedded Controller

Empower your creativity

V850

Embedded Controller

The V850 Series of high-performance microcontrollers answers many different application system needs. It realizes superlatively low power consumption and low noise while offering high performance and a wide array of functions. The broad V850 product lineup provides optimum solutions for the next-generation systems of customers.

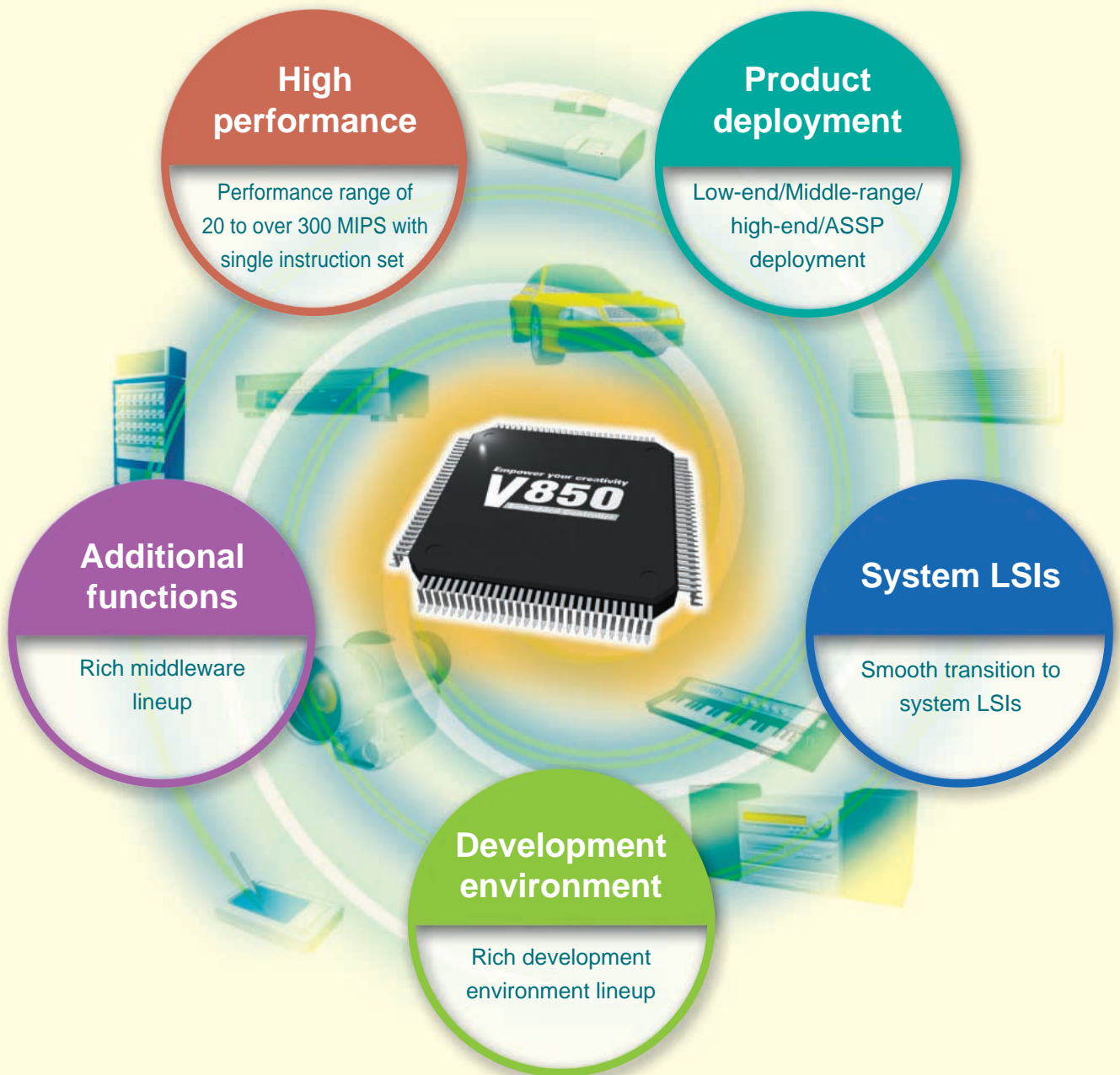

INDEX

Roadmap/Features

V850 Series Product Roadmap	4	5 Keys of V850	6
NEC Electronics Microcontroller Deployment	5		
Set Application Examples	5		

04

Product Lineup

Low-End Lineup	8	ASSP Lineup	14
Middle-Range Lineup	10	Memory Lineup	18
High-End Lineup	12	Package Lineup	19

08

CPU

CPU Roadmap	20	V850 Series Common Architecture	22
CPU Core Function Comparison	20	V850E1,V850ES Architecture	26
System LSI Support	21	V850E2 Architecture	27

20

Variety of Peripheral Functions

Memory Access Functions	28	Serial Interface	31
Analog Circuits	29	Other	32
Timer/Counter	30		

28

Performance

V850 Series Benchmark	34
Low Power Consumption	34
Low Noise Countermeasures	35

34

Middleware

V850 Series Middleware List	36	Text to Speech (for Japanese Text)	37
Speech Recognition	37		
JPEG	37		

36

Flash

Features	38	Flash Memory Programmers	40
Rewrite Modes	38		
Flash Specifications List	39		

38

Product Specifications List

Low-End Lineup	42	High-End Lineup	50
Middle-Range Lineup	44		
ASSP Lineup	47		

42

Development Environment

Low-Price Development Environment Lineup	53	V850 Series Development Environment	57
Development Flow	54	Software Product	59
Development Tools	54		

52

Information Dissemination

V850 Series Website	62
---------------------	----

62

V850 Series Product Roadmap

Continuously evolving V850 Series through an expanding product lineup

V850E2 core 200 to 400 MHz

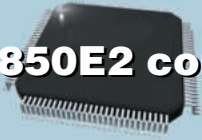

CPU core release completed
Product deployment under planning

V850E1 core

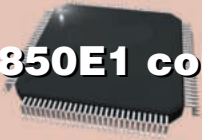

150 MHz @ 215 MIPS

High-end lineup

High performance: On-chip MEMC/DMA

- Frequency: 33 to 150 MHz
- Memory size: ROM: ROM-less to 512 KB
RAM: 4 to 128 KB
- PKG: 100 to 240 pins (QFP & FBGA)

ASSP lineup

Inverter control
DVC control
Car audio control
Power meter control
Dashboard control

- Frequency: 16 to 64 MHz
- Memory size: ROM: ROM-less to 640 KB
RAM: 4 to 48 KB
- PKG: 64 to 257 pins (QFP & FBGA)

V850 core



33 MHz @ 38 MIPS

Middle-range lineup

Realization of low EMI noise

- Frequency: 20 to 34 MHz
- Memory size: ROM: ROM-loss to 640 KB
RAM: 4 to 48 KB
- PKG: 100 to 144 pins (QFP & FBGA)

V850ES core



20 MHz @ 29 MIPS

Low-end lineup

High cost-performance

- Frequency: 20 MHz
- Memory size: ROM: 64 to 256 KB
RAM: 4 to 16 KB
- PKG: 64 to 144 pins (QFP)



Standard lineups

Field-specific lineups

NEC Electronics Microcontroller Deployment

Upward compatible instruction sets

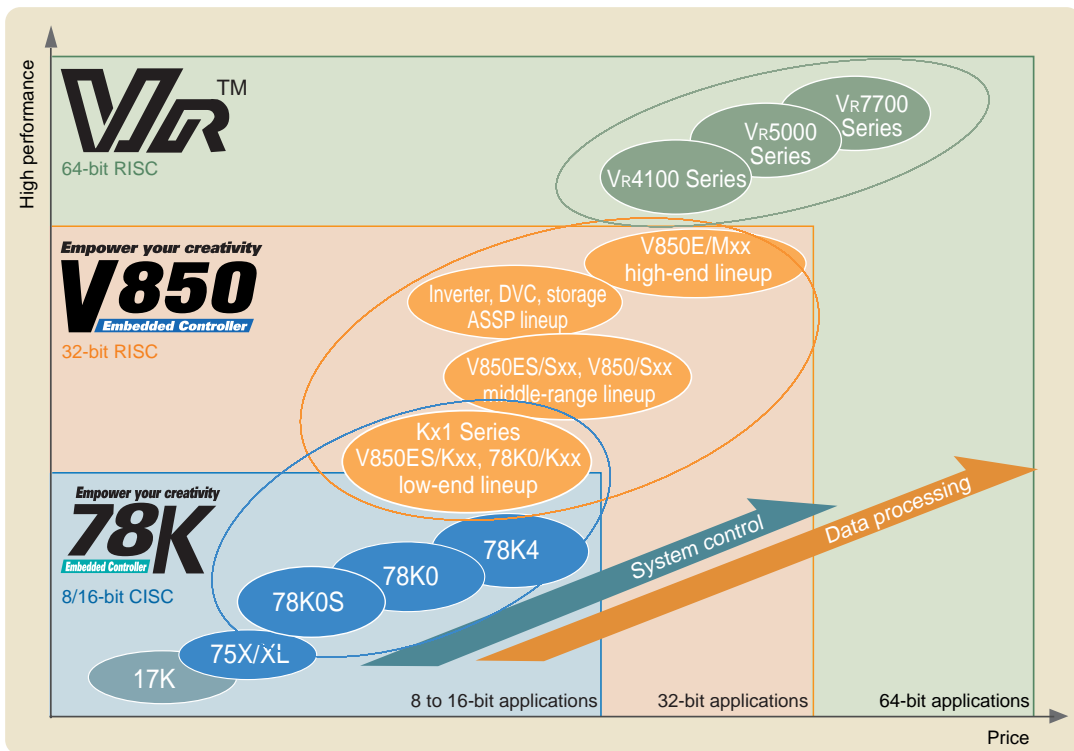

Set Application Examples

The V850 Series is suitable for various application fields and raises the commercial value of customer systems.

Automotive



Engines, dashboards, power steering, ABS

Audio



Car audio, portable audio, component stereo systems

Portable devices



PDA, IC recorders

Camera



DVC, DSC, SLR cameras

Computer peripherals



Laser-beam printers, inkjet printers, scanners, fax machines

Home appliances



Air conditioners, refrigerators, washing machines, microwave ovens

Industrial equipment

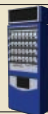

Industrial motors, control equipment, vending machines, power meters

Video and recording equipment



DVD players, D-VHS, industrial cameras

Other



Electronic instruments, electric bidets, toys, learning devices, remote controllers, etc.

Roadmap/Features

5 Keys of V850

5 points supporting the high performance of the V850 Series

High performance

Performance ranging from 20 to over 300 MIPS with single instruction set

High performance



- Compared to 8-/16-bit microcontroller, offer a MIPS performance 10 or more times higher for the same frequency, and 2 to 3 times higher at the actual application level (based on NEC evaluation)
- System operation at frequencies 1/2 to 1/3 those of 8-/16-bit microcontrollers is enabled, contributing to lowering system power consumption.
- The V850 core, V850ES core, V850E1 core, and V850E2 core are upward compatible at the object level.

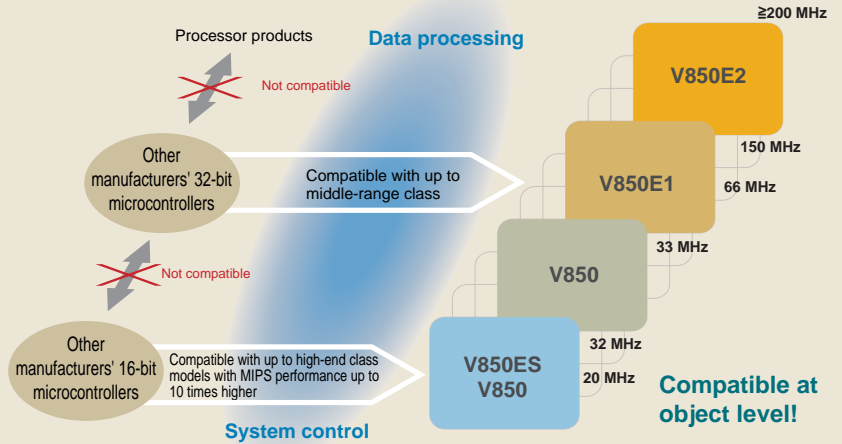

Product lineup

Low-end/Middle-range/High-end/ASSP deployment

Product lineup



- Low-end lineup: Kx1 Series of general-purpose microcontrollers for 16 to 32-bit market designed for high cost-performance.
- Middle-range lineup: Low noise, low power consumption, large-capacity memory lineup, low-voltage operation support
- High-End lineup: Designed for high performance, on-chip memory controller and DMA
- ASSP lineup: Field-specific product lineup, on-chip dedicated hardware

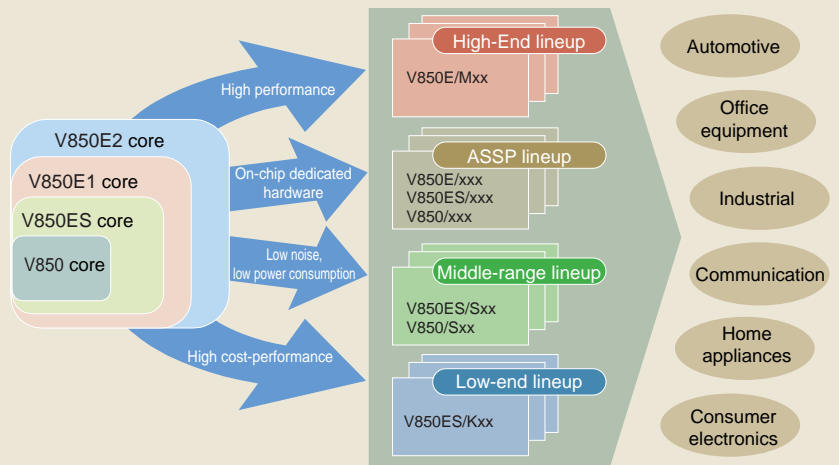

Additional functions

Rich middleware lineup

Additional functions



- Realization of systems with high added value through the addition of supplementary functions to existing systems via middleware
- Realization of functions heretofore realized with peripheral ICs through V850 + middleware, reducing development time and reducing system costs
- Rich lineup of video, audio, network-related, and other middleware tuned for V850 Series

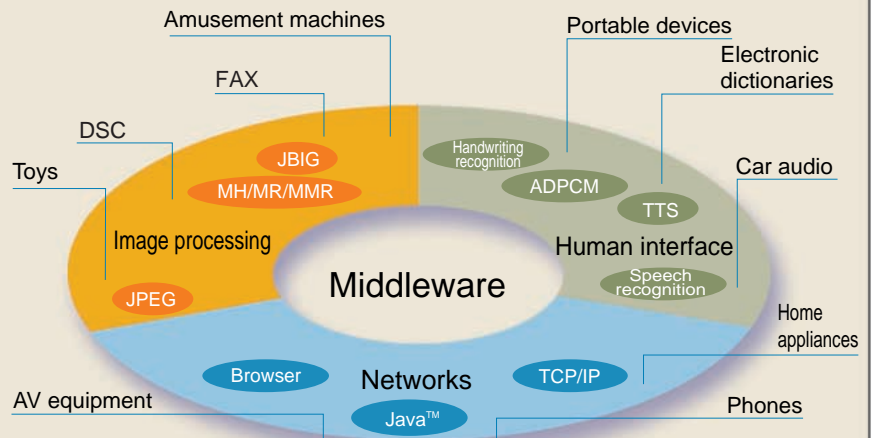



System LSI

Smooth transition to system LSIs



System LSI



- The V850 Series is also being actively expanded for ASIC CPU cores, realizing smooth transition to system LSIs
- The following elements essential for system LSIs are provided on a timely basis:
 - <1> Leading-edge process technology
 - <2> High-performance CPU core
 - <3> Rich lineup of IP cores
 - <4> Top-down design environment
 - <5> Flexible application design

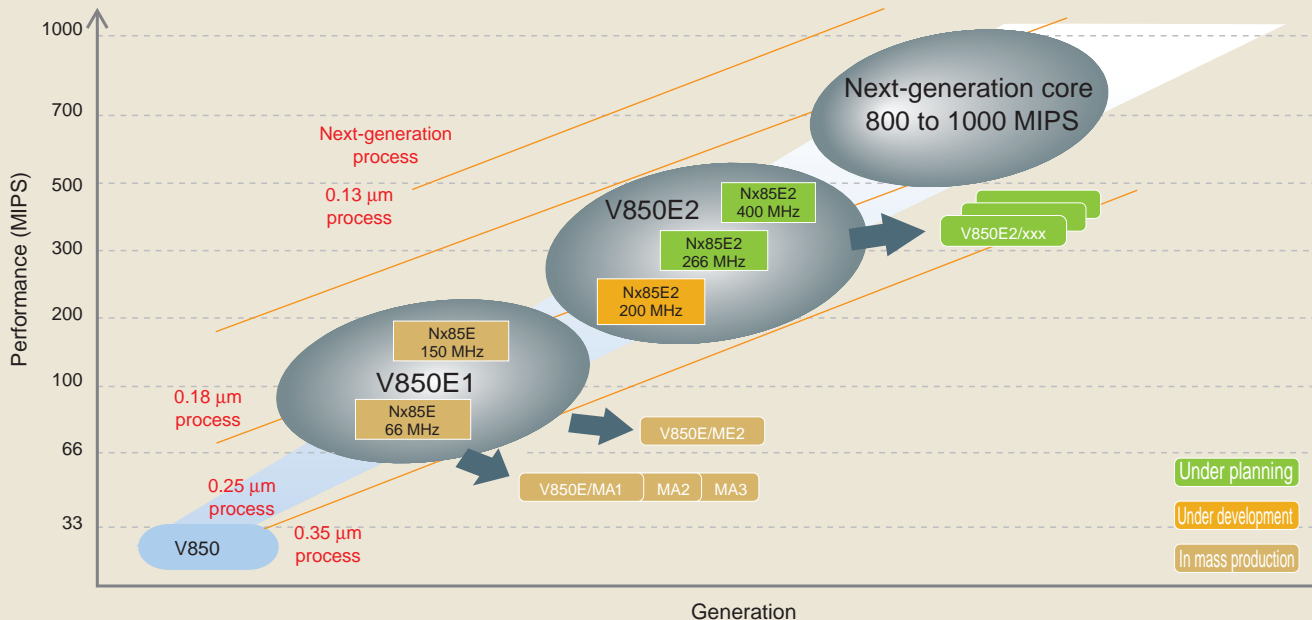
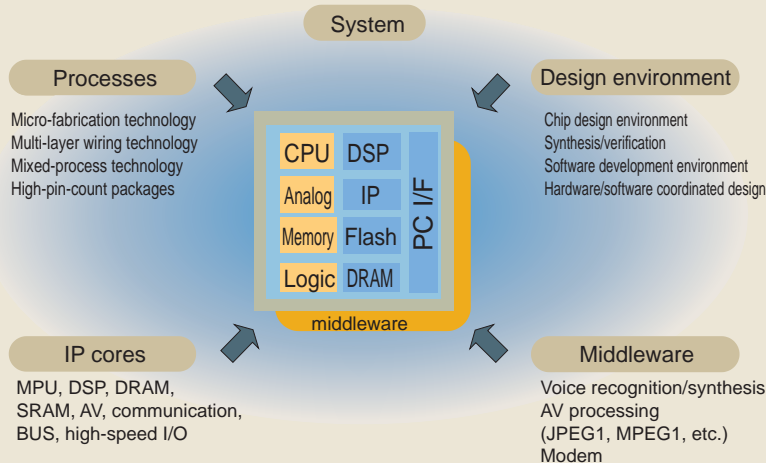

Development environment

Rich development environment lineup

Development environment



- IECUBE™, a low-cost high-performance emulator, and N-Wire CARD, an ultra-low cost on-chip emulator are available
- Realization of better connectivity with target boards, addition of GUI customization function, improved online help, etc.
- Realization of shorter development TAT through support of quick and accurate software development via a rich development environment lineup featuring easy operation and sophisticated functions

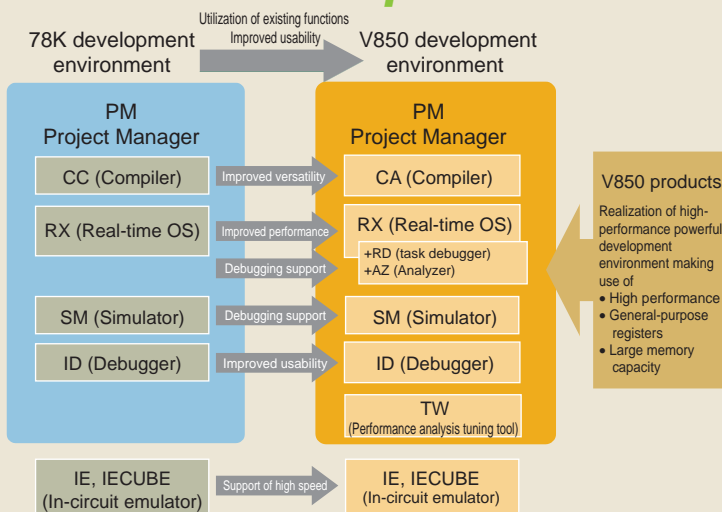

Product Lineup

Low-End Lineup

Kx1 Series of general-purpose microcontrollers for 16 to 32-bit market designed for high cost-performance

Under planning

Under development

In mass production

8-bit microcontrollers

78K0/Kxx
78K0S/Kxx

NEXT Generation

V850ES/KE1+

64-pin version

V850ES/KF1+

80-pin version

V850ES/KG1+

100-pin version

V850ES/KJ1+

144-pin version

V850ES/KE1

64-pin version

V850ES/KF1

80-pin version

V850ES/KG1

100-pin version

V850ES/KJ1

144-pin version

Single-power-supply flash
On-chip POC/LVI
On-chip debugging function
DMA function (only KG1+, KJ1+)

- ▲ Rich memory and package lineup
- ▲ Large array of on-chip peripheral functions common with 78K0/Kx1 of 8-bit microcontrollers
- ▲ Low EMI noise design
- ▲ Development environment usable in common for all series
- ▲ Wide voltage range support (2.7 to 5.5 V)
- ▲ Single-power-supply flash lineup (self programming, EEPROM™ emulation support)

Kx1+ features

Kx1+ are microcontrollers featuring additional functions.

	V850ES/Kx1		V850ES/Kx1+
Runaway detection function	Watchdog timer running on main clock	plus	High-reliability watchdog timer operating with uninterruptible Ring OSC
Voltage detection circuit	None	▶	On-chip voltage detection circuit (LVI: variable detection voltage)
Reset functions	External reset, WDT reset	plus	•On-chip reset detection circuit (POC: Fixed voltage) •Also possible with voltage detection circuit (LVI: Variable detection voltage)
DMA function	None	plus	4 on-chip channels (KG1+, KJ1+)
Oscillation stabilization time reduction	Fixed at reset release	▶	Can be reduced with optional function
A/D converter	Conversion time 14 μs (min.) Successive approximation mode	▶	Conversion interval of 3 μs (min.) Successive approximation, scan mode
LIN bus interface	No hardware	▶	1 hardware channel for each product

Kx1 Series lineup

Rich memory & package lineup

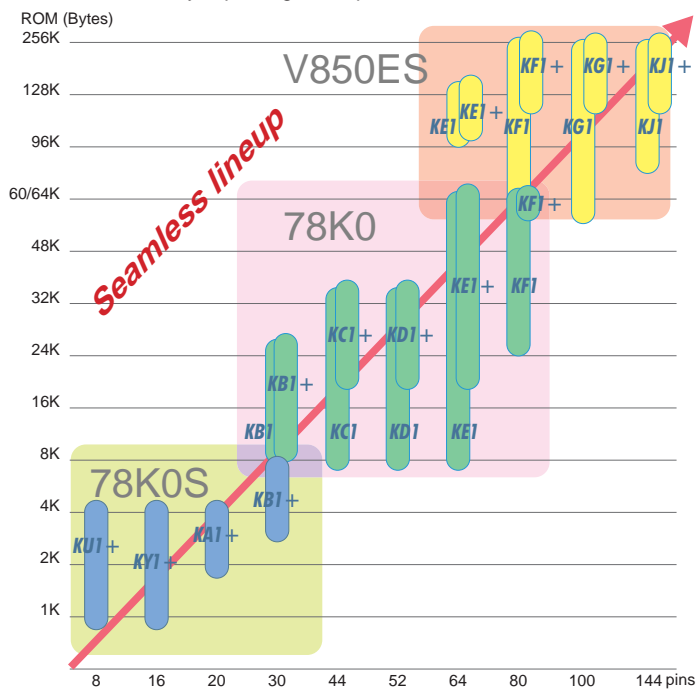

Product specifications

Item	V850ES/Kx1			
	KE1	KF1	KG1	KJ1
CPU core	V850ES			
Performance	29 MIPS (@ 20 MHz)			
Maximum operating frequency	20 MHz (main clock) 32.768 kHz (subclock)			
Internal flash memory	128 KB	256 KB/128 KB/96 KB/64 KB		256 KB/128 KB
Internal mask ROM	128 KB			128 KB/96 KB
Internal RAM	4 KB	12 KB/6 KB/4 KB	16 KB/6 KB/4 KB	16 KB/6 KB
Power supply voltage	4.5 V to 5.5 V @ 20 MHz 4.0 V to 5.5 V @ 16 MHz 2.7 V to 5.5 V @ 10 MHz			
External bus	Address: Multiplexed		Address: Multiplexed/separate	
Timer/counter	16-bit×2 ch	16-bit×2 ch (256 KB: 3 ch)	16-bit×4 ch (256 KB: 5 ch)	16-bit×6 ch (256 KB: 7 ch)
Serial interface	CSI×2 ch, UART×2 ch I ² C×1 ch*	CSI×2 ch, UART×2 ch I ² C×1 ch* CSI with automatic transfer function×1 ch 10-bit×8 ch	CSI×2 ch, UART×2 ch I ² C×1 ch* CSI with automatic transfer function×2 ch	CSI×3 ch, UART×2 ch UART/I ² C×1 ch*, I ² C×1 ch* CSI with automatic transfer function×2 ch 10-bit×16 ch
A/D converter				
D/A converter				
DMA controller	8-bit×2 ch			
Other peripheral functions	ROM correction function, real-time output, key return function			On-chip debug function, ROM correction function, real-time output, key-return function
I/O	51	67	84	128
Power consumption (mask version, Typ.)	150 mW (20 MHz @5V)			
Package	64-pin TQFP(12×12 mm) 64-pin LQFP(10×10 mm)	80-pin TQFP(12×12 mm) 80-pin QFP(14×14 mm)	100-pin LQFP(14×14 mm) 100-pin QFP(14×20 mm)	144-pin LQFP(20×20 mm)

* : Only Y products have an on-chip I²C interface.

System cost reduction

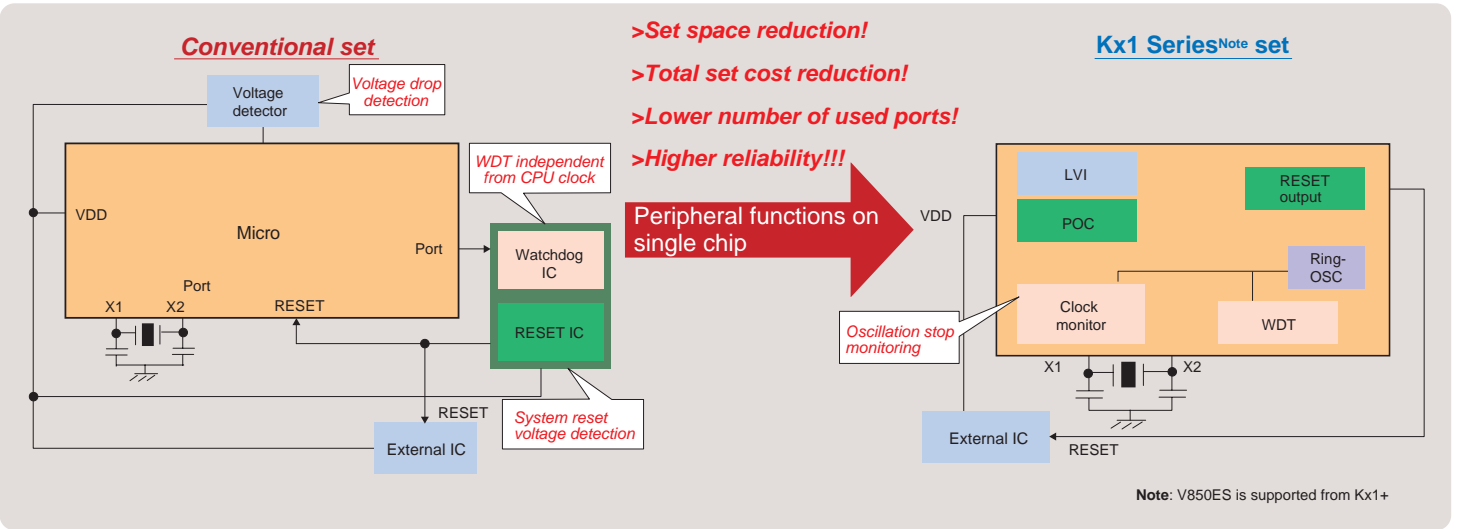

Common peripheral functions

Large array of peripheral functions common with 8-bit 78K0 Series

	78K0S				78K0												V850ES											
	KU1+	KY1+	KA1+	KB1+	KB1	KB1+	KC1	KC1+	KD1	KE1	KE1+	KF1	KF1+	KE1	KE1+	KF1	KF1+	KG1	KG1+	KJ1	KJ1+							
ROM size(bytes)	1K 2K 4K	1K 2K 4K	2K 4K	4K 8K	8K 16K 24K	16K 24K	8K 16K 24K 32K	16K 24K 32K	16K 24K 32K	8K 16K	24K 32K 48K 60K	24K 32K 48K 60K	24K 48K 60K	128K	128K	64K 96K 128K	256K 256K	128K 96K 256K	128K 96K 256K	128K	128K	256K						
TMP	1	1	1	1	1	1	1	1	1	1	1	1	1	1	1	1	1	1	1	1	1	1	1					
TM0	1	1	1	1	1	1	1	1	1	1	1	1	1	1	1	1	1	1	1	1	1	1	1					
TM5	1	1	1	1	1	1	1	1	1	1	1	1	1	1	1	1	1	1	1	1	1	1	1					
TMH	1	1	1	1	1	1	1	1	1	1	1	1	1	1	1	1	1	1	1	1	1	1	1					
TM8	1	1	1	1	1	1	1	1	1	1	1	1	1	1	1	1	1	1	1	1	1	1	1					
WT	1	1	1	1	1	1	1	1	1	1	1	1	1	1	1	1	1	1	1	1	1	1	1					
WDT(Powerful WDT)	1	1	1	1	1	1	1	1	1	1	1	1	1	1	1	1	1	1	1	1	1	1	1					
DMA	1	1	1	1	1	1	1	1	1	1	1	1	1	1	1	1	1	1	1	1	1	1	1					
CSI	1	1	1	1	1	1	1	1	1	1	1	1	1	1	1	1	1	1	1	1	1	1	1					
Auto CSI	1	1	1	1	1	1	1	1	1	1	1	1	1	1	1	1	1	1	1	1	1	1	1					
UART	1	1	1	1	1	1	1	1	1	1	1	1	1	1	1	1	1	1	1	1	1	1	1					
UART(LIN)	1	1	1	1	1	1	1	1	1	1	1	1	1	1	1	1	1	1	1	1	1	1	1					
IIC	1	1	1	1	1	1	1	1	1	1	1	1	1	1	1	1	1	1	1	1	1	1	1					
A/D	4 ch	4 ch	4 ch	4 ch	4 ch	4 ch	8 ch	8 ch	8 ch	8 ch	8 ch	8 ch	8 ch	8 ch	8 ch	8 ch	8 ch	8 ch	8 ch	8 ch	8 ch	16 ch	16 ch					
D/A	4 ch	4 ch	4 ch	4 ch	4 ch	4 ch	8 ch	8 ch	8 ch	8 ch	8 ch	8 ch	8 ch	8 ch	8 ch	8 ch	8 ch	8 ch	8 ch	8 ch	8 ch	16 ch	16 ch					
Ring-OSC(8 MHz)	Y	Y	Y	Y	Y	Y	Y	Y	Y	Y	Y	Y	Y	Y	Y	Y	Y	Y	Y	Y	Y	Y	Y					
Ring-OSC(240 kHz)	Y*	Y*	Y*	Y*	Y	Y	Y	Y	Y	Y	Y	Y	Y	Y	Y	Y	Y	Y	Y	Y	Y	Y	Y					
Sub-OSC	Y	Y	Y	Y	Y	Y	Y	Y	Y	Y	Y	Y	Y	Y	Y	Y	Y	Y	Y	Y	Y	Y	Y					
REG.	Y	Y	Y	Y	Y	Y	Y	Y	Y	Y	Y	Y	Y	Y	Y	Y	Y	Y	Y	Y	Y	Y	Y					
Key return	Y	Y	Y	Y	Y	Y	Y	Y	Y	Y	Y	Y	Y	Y	Y	Y	Y	Y	Y	Y	Y	Y	Y					
ROM correction	Y	Y	Y	Y	Y	Y	Y	Y	Y	Y	Y	Y	Y	Y	Y	Y	Y	Y	Y	Y	Y	Y	Y					
Real-time Output	Y	Y	Y	Y	Y	Y	Y	Y	Y	Y	Y	Y	Y	Y	Y	Y	Y	Y	Y	Y	Y	Y	Y					
H.MUL/DIV	Y	Y	Y	Y	Y	Y	Y	Y	Y	Y	Y	Y	Y	Y	Y	Y	Y	Y	Y	Y	Y	Y	Y					
POC/LVI	Y	Y	Y	Y	Y	Y	Y	Y	Y	Y	Y	Y	Y	Y	Y	Y	Y	Y	Y	Y	Y	Y	Y					
RESET OUT	Y	Y	Y	Y	Y	Y	Y	Y	Y	Y	Y	Y	Y	Y	Y	Y	Y	Y	Y	Y	Y	Y	Y					
Clock Monitor	Y	Y	Y	Y	Y	Y	Y	Y	Y	Y	Y	Y	Y	Y	Y	Y	Y	Y	Y	Y	Y	Y	Y					

*: Only for WDT/TMH
 Common to all products Common to V850ES products Common to 78K0 products Common to 78K0S products

Item	V850ES/Kx1+			
	KE1+	KF1+	KG1+	KJ1+
CPU core	V850ES			
Performance	29 MIPS (@ 20 MHz)			
Maximum operating frequency	20 MHz (main clock) 32.768 MHz (subclock)			
Internal flash memory	128 KB		256 KB/128 KB	
Internal mask ROM	128 KB			
Internal RAM	4 KB	12 KB/6 KB		16KB/6KB
Power supply voltage	4.5 V to 5.5 V @ 20 MHz 4.0 V to 5.5 V @ 16 MHz 2.7 V to 5.5 V @ 10 MHz			
External bus	Address: Multiplexed		Address: Multiplexed/separate	
Timer/counter	16-bit×2 ch	16-bit×3 ch	16-bit×5 ch	16-bit×7 ch
Serial interface	CS I × 2 ch, LIN compatible UART × 1 ch UART × 1 ch, I ² C × 1 ch*		CS I × 1 ch, LIN compatible UART × 1 ch UART × 1 ch, I ² C × 1 ch CSI with automatic transfer function × 2 ch	
	CS I × 2 ch, LIN compatible UART × 1 ch UART × 1 ch, I ² C × 1 ch CSI with automatic transfer function × 1 ch		CS I × 1 ch, LIN compatible UART × 1 ch UART × 1 ch, I ² C × 1 ch CSI with automatic transfer function × 2 ch	
A/D converter	10-bit×8 ch		10-bit×16 ch	
D/A converter	-		8-bit×2 ch	
DMA controller	-		4ch	
Other peripheral functions	POC/LVI, Ring OSC, clock monitor function		On-chip debug function, POC/LVI, Ring OSC, clock monitor function, real-time output, key-return function	
I/O	51	67	84	127 (Y products, 128)
Power consumption (mask ROM version, Typ.)	T.B.D.			
Package	64-pin TQFP (12×12 mm) 64-pin LQFP (10×10 mm)	80-pin TQFP (12×12 mm) 80-pin QFP (14×14 mm)	100-pin LQFP (14×14 mm) 100-pin QFP (14×20 mm)	144-pin LQFP (20×20 mm)

*: Only Y products have an on-chip I²C interface.

Product Lineup

Middle-Range Lineup

Large-capacity memory, 2.5 V/3 V/5 V general-purpose product lineup

Under planning

Under development

In mass production

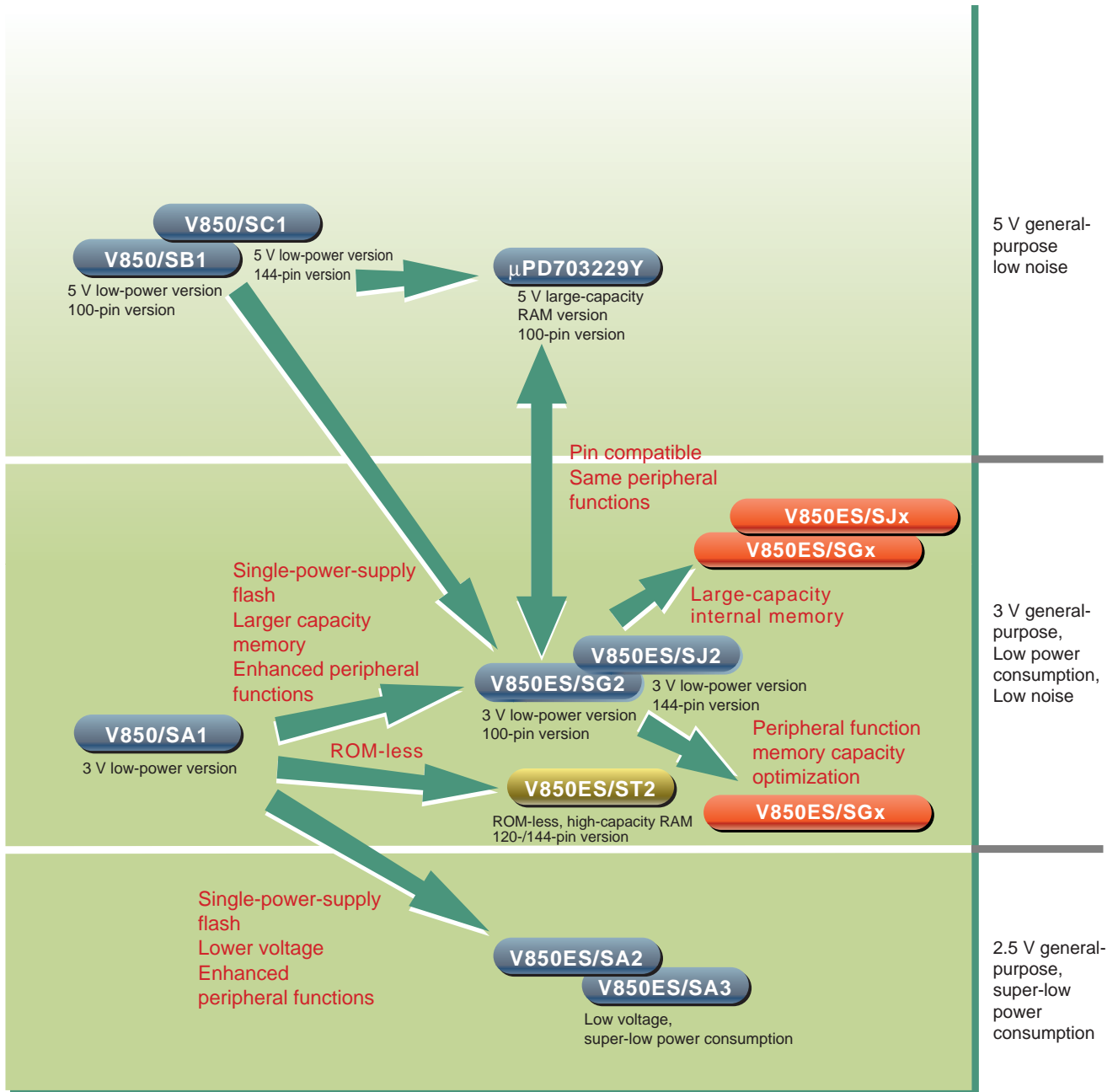

◆ Product specifications ◆

Item	V850ES/SAx		V850ES/Sx2		μPD703229Y
	SA2	SA3	SG2	SJ2	
CPU core	V850ES		V850ES		V850ES
Performance	29 MIPS (@ 20 MHz)		29 MIPS (@ 20 MHz)		29 MIPS (@ 20 MHz)
Maximum operating frequency	20 MHz (main clock) 32.768 kHz (subclock)		20 MHz (main clock) 32.768 kHz (subclock)		20 MHz (main clock) 32.768 kHz (subclock)
Internal flash memory	256 KB		640KB/384KB		384KB
Internal mask ROM	256 KB/128 KB	256 KB	640KB/512KB/384KB/256KB	640KB/512KB/384KB	384KB
Internal RAM	16 KB/8 KB	16 KB	48KB/40KB/32KB/24KB	48KB/40KB/32KB	32KB
Power supply voltage	2.2 V to 2.7 V		2.85 V to 3.6 V		3.5 V to 5.5 V (internal) 3.0 V to 5.5 V (external bus)
External bus	Address: Multiplexed/separate Data: 8/16 bits		Address: Multiplexed/separate Data: 8/16 bits		Address: Multiplexed Data: 8/16 bits
Timer/counter	16-bit × 2 ch 8-bit × 4 ch WDT × 1 ch		16-bit × 8 ch WDT × 1 ch Watch timer × 1 ch	16-bit × 11 ch WDT × 1 ch Watch timer × 1 ch	16-bit × 6 ch WDT × 1 ch Watch timer × 1 ch
Serial interface	CSI × 2 ch, CSI/UART × 1 ch UART × 1 ch, CSI/I ² C × 1 ch*	CSI × 3 ch, CSI/UART × 1 ch UART × 1 ch, CSI/I ² C × 1 ch*	CSI × 3 ch, CSI/LIN compatible UART × 1 ch CSI/I ² C × 1 ch* LIN compatible UART/I ² C × 2 ch*	CSI × 4 ch, CSI/LIN compatible UART × 1 ch LIN compatible UART × 1 ch, CSI/I ² C × 1 ch* UART/I ² C × 2 ch*	CSI × 1 ch, LIN compatible UART × 3 ch CSI/I ² C × 1 ch*
A/D converter	10-bit × 12 ch		10-bit × 12 ch		10-bit × 12 ch
D/A converter	8-bit × 2 ch		8-bit × 2 ch		-
DMA controller	4 ch		4 ch		4 ch
Other peripheral functions	Real-time counter (watch function), ROM correction function		On-chip debugging function, CRC circuit, ROM correction function, Ring OSC, low voltage detection circuit, clock monitoring function, automotive bus (IEBus™, aFCAN) ^{Note}		On-chip debugging function, ROM correction function, low voltage detection circuit, clock monitoring function
I/O	82	102	84	128	84
Power consumption (mask ROM version, Typ.)	38 mW (20 MHz @ 2.5 V)		59.4 mW (20 MHz @ 3.3 V)	66 mW (20 MHz @ 3.3 V)	100 mW (20 MHz @ 5 V)
Package	100-pin TQFP (14 × 14 mm)	121-pin FBGA (12 × 12 mm)	100-pin LQFP (14 × 14 mm) 100-pin QFP (14 × 20 mm)	144-pin LQFP (20 × 20 mm)	100-pin LQFP (14 × 14 mm)

* : Only Y products have an on-chip I²C interface.

Note Products without automotive bus, products with on-chip IEBus, and products with on-chip aFCAN are available.

Features

V850ES/SG2, SJ2

- Low EMI noise
- 20 MHz @ 2.85 to 3.6 V operation
- 5 V withstand voltage ports incorporated, and 5 V output is possible by setting the N-ch open-drain output
- On-chip large-capacity single-power-supply flash memory
- ROM/RAM:640 KB/48 KB, 512 KB/40 KB, 384 KB/32 KB, 256 KB/24 KB (SG2 only)
- Automotive on-chip bus support: IEBus*, aFCAN* (*: Only products with on-chip SG2, SJ2)
- On-chip debugging function
- 100-pin QFP (SG2)/100-pin LQFP (SG2)/144-pin LQFP (SJ2)

μPD70F3229Y, 703229Y

- Large-capacity memory
- ROM/RAM:384 KB/32 KB
- 3 V/5 V mixed system support (Internal: 3.3 V/External: 5 V)
- Peripheral functions and pin assignment common with V850ES/SG2
- 100-pin LQFP

V850ES/ST2

- ROM-less version
- On-chip high-capacity RAM (48 KB)
- 3.3 V, 34 MHz operation
- Thin-type, compact type packages supported: 120-pin TQFP/144-pin LQFP

V850ES/SA2, SA3

- Min. 2.2 V low-voltage operation (including A/D, D/A converter, flash)
- Low power consumption and high-speed operation during 38 mW @ 2.5 V, 20 MHz operation
- Single-power-supply flash
- ROM/RAM: 256 KB/16 KB (SA2, SA3), 128 K/8 KB (SA2 mask ROM version)
- Thin and compact package support: 100-pin TQFP (SA2)/121-pin FBGA (SA3)

V850/SA1

- Low power consumption and high-speed operation during 66 mW @ 3.3 V, 20 MHz operation
- Large memory selection
- ROM/RAM:256 KB/8 KB, 128 KB/4 KB, 64 KB/4 KB
- 100-pin LQFP/121-pin FBGA

V850/SB1

- Low EMI noise
- Large-capacity memory and large memory selection
- ROM/RAM:512 KB/24 KB, 384 KB/24 KB, 256 KB/16 KB, 128 KB/8 KB
- 100-pin QFP/100-pin LQFP

V850/SC1

- Low EMI noise
- Large-capacity memory (ROM/RAM: 512 KB/24 KB)
- Enhanced peripheral functions for SB1
- 144-pin LQFP

Item	V850/SA1	V850/SB1	V850/SC1	V850ES/ST2
CPU core	V850	V850	V850	V850ES
Performance	23 MIPS (@ 20 MHz)	23 MIPS (@ 20 MHz)	23 MIPS (@ 20 MHz)	-
Maximum operating frequency	20 MHz (main clock) 32.768 kHz (subclock)	20 MHz (main clock) 32.768 kHz (subclock)	20 MHz (main clock) 32.768 kHz (subclock)	34 MHz
Internal flash memory	256 KB/128 KB	512 KB/384 KB/256 KB	512 KB	-
Internal mask ROM	256 KB/128 KB/64 KB	512 KB/384 KB/256 KB/128 KB	512 KB	ROM-less
Internal RAM	8 KB/4 KB	24 KB/16 KB/8 KB	24 KB	48 KB
Power supply voltage	2.7 V to 3.6 V (@ 17 MHz) 3.0 V to 3.6 V (@ 20 MHz)	4.0 V to 5.5 V	3.5 V to 5.5 V (mask ROM versions) 4.0 V to 5.5 V (flash memory versions)	3.0 V to 3.6 V
External bus	Address: Multiplexed/separate Data: 16-bits	Address: Multiplexed/separate Data: 16-bits	Address: Multiplexed/separate Data: 16-bits	Address: Separate/multiplexed (selectable only for CSI) Data: 8/16
Timer/counter	16-bit×2 ch 8-bit×4 ch WDT×1 ch Watch timer×1 ch	16-bit×2 ch 8-bit×6 ch WDT×1 ch Watch timer×1 ch	16-bit×10 ch WDT×1 ch Watch timer×1 ch	16-bit×7 ch WDT×1 ch
Serial interface	CSI×1 ch, CSI/UART×1 ch CSI/I ² C×1 ch*, UART×1 ch	CSI×1 ch, CSI/UART×2 ch CSI/I ² C×2 ch*	CSI×2 ch, CSI/UART×2 ch UART×2 ch, CSI/I ² C×2 ch	CSI×1 ch, CSI/UART×1 ch UART×1 ch
A/D converter	10-bit×12 ch	10-bit×12 ch	10-bit×12 ch	10-bit×8 ch
D/A converter	-	-	-	8-bit×2 ch
DMA controller	3 ch (internal RAM-on-chip peripheral I/O)	6ch (internal RAM-on-chip peripheral I/O)	6 ch (internal RAM-on-chip peripheral I/O)	-
Other peripheral functions	-	ROM correction function	ROM correction function	Real-time output
I/O	85	83	124	65
Power consumption (mask ROM version, Typ.)	66 mW (20 MHz @ 3.3 V) 56 mW (17 MHz @ 3 V)	125 mW (20 MHz @ 5 V)	125 mW (20 MHz @ 5 V)	T.B.D.
Package	100-pin LQFP (14×14 mm) 121-pin FBGA (12×12 mm)	100-pin LQFP (14×14 mm) 100-pin QFP (14×20 mm)	144-pin LQFP (20×20 mm)	120-pin TQFP (14×14 mm) 144-pin LQFP (20×20 mm)

* : Only Y products have an on-chip I²C interface.

Product Lineup

High-End Lineup

High performance, on-chip MEMC/DMA

Under planning

In mass production

Superscalar

On-chip instruction cache & RAM

Higher performance
On-chip instruction cache
On-chip USB

V850E/ME2

150 MHz @ 215 MIPS
176-pin/240-pin

V850E2/Mxx

Higher performance
Parallel execution

On-chip SDRAM controller

V850E/MA1

50 MHz @ 67 MIPS
144-pin/161-pin

V850E/MA3

80 MHz @ 106 MIPS
144-pin/161-pin

V850Ex/Mxx

Higher performance
Large-capacity internal memory

Higher performance
Large-capacity internal memory
Enhanced peripheral functions

V850E/MA2

40 MHz, ROM-less
100-pin

V850E/MS1

33 MHz @ 47 MIPS
144-pin/157-pin

V850E/MS2

33 MHz, ROM-less
100-pin

Features

V850E/ME2

- 215 MIPS @150 MHz, internal 1.5 V/external 3.3 V operation ROM-less microcontroller
- Large-capacity internal RAM (128 KB), real-time control
- On-chip SSCG*, EMI peak reduction
- USB full-speed (function), on-chip debugging function
On-chip SDRAM interface
- 176-pin LQFP/240-pin FBGA

*Spread Spectrum Frequency Synthesizer Clock Generator

V850E/MA1,MA2

- 67 MIPS @50 MHz
Internal 3.3 V/external 5 V tolerant operation single-chip microcontroller (MA1)
- ROM-less product lineup also available
- 40 MHz @3.3 V ROM-less microcontroller (MA2)
- ROM/RAM: 256 KB/10 KB (MA1), ROM-less/4 KB (MA1, MA2)
- On-chip SDRAM interface, DMA
- 144-pin LQFP/161-pin FBGA (MA1), 100-pin LQFP (MA2)

V850E/MA3

- 106 MIPS @80 MHz, internal 2.5 V/external 3.3 V operation single-chip microcontroller
- Large-capacity internal ROM/RAM (512 KB/32 KB)
- Internal single power supply flash
- SDRAM interface, motor control function, on-chip debugging function
- 144-pin LQFP/161-pin FBGA

V850E/MS1,MS2

- 47 MIPS @33 MHz, 3.3 V & 5 V single-chip microcontroller (MS1)
- ROM-less product (Max. 40 MHz) lineup available
- 33 MHz @ internal 3.3 V/external 5 V ROM-less microcontroller (MS2)
- ROM/RAM: 128 KB/4 KB (MS1), ROM-less/4 KB (MS1, MS2)
- 144-pin LQFP (MS1)/157-pin FBGA (MS1)/100-pin LQFP (MS2)

Product specifications

Item	V850E/ME2	V850E/MA3	V850E/MA1	V850E/MA2	V850E/MS1	V850E/MS2
	V850E1	V850E1	V850E1	V850E1	V850E1	V850E1
Performance	215 MIPS (@ 150 MHz)	106 MIPS (@ 80 MHz)	67 MIPS (@ 50 MHz)	-	47 MIPS (@ 33 MHz)	-
Maximum operating frequency	150 MHz	80 MHz	50 MHz	40 MHz	33 MHz (internal ROM products) 40 MHz (ROM-less products)	33 MHz
Internal flash memory	-	512 KB	256 KB	-	128 KB	-
Internal mask ROM	-	512 KB/256 KB	256 KB/128 KB/ROM-less	ROM-less	128 KB/96 KB/ROM-less	ROM-less
Internal RAM	Instruction RAM: 128 KB; Data RAM: 16 KB	32 KB/16 KB	10 KB/4 KB	4 KB	4 KB	4 KB
Cache	-	-	-	-	-	-
Power supply voltage	1.35 V to 1.65 V (internal) ^{Note} 3.0 V to 3.6 V (external)	2.3 V to 2.7 V (internal) 3.0 V to 3.6 V (external)	3.0 V to 3.6 V	3.0 V to 3.6 V	3.0 V to 3.6 V (internal/external) (3 V products) 3.0 V to 3.6 V (internal) (5 V products) 4.5 V to 5.5 V (external)	3.0 V to 3.6 V (internal) 4.5 V to 5.5 V (external)
Memory controller	SDRAM, SRAM, etc.	SDRAM, SRAM, etc.	SDRAM, EDO DRAM, SRAM, etc.	SDRAM, SRAM, etc.	EDO DRAM, SRAM, etc.	EDO DRAM, SRAM, etc.
External bus	Address: Separate Data: 8/16/32 bits	Address: Separate/multiplexed Data: 8/16 bits	Address: Separate Data: 8/16 bits	Address: Separate Data: 8/16 bits	Address: Separate Data: 8/16 bits	Address: Separate Data: 8/16 bits
Timer/counter	16-bit × 12 ch	16-bit × 9 ch WDT × 1 ch	16-bit × 8 ch	16-bit × 6 ch	16-bit × 8 ch	16-bit × 6 ch
Serial interface	CSI × 1 ch, CSI/UART × 1 ch UART × 1 ch	CSI/UART × 3 ch, UART/I ² C × 1 ch*	CSI × 1 ch, CSI/UART × 2 ch UART × 1 ch	CSI/UART × 2 ch	CSI × 2 ch, CSI/UART × 2 ch	CSI/UART × 2 ch
A/D converter	10-bit × 8 ch	10-bit × 8 ch	10-bit × 8 ch	10-bit × 4 ch	10-bit × 8 ch	10-bit × 4 ch
D/A converter	-	8-bit × 2 ch	-	-	-	-
DMA controller	4 ch	4 ch	4 ch	4 ch	4 ch	4 ch
Other peripheral functions	USB × 1 ch, on-chip debugging function (with trace), PWM output: 2 ch	ROM correction function On-chip debugging function	PWM output: 2 ch	-	-	-
I/O	78	112	115	79	131	57
Power consumption (mask ROM version, Typ.)	200 mW (150 MHz @ 1.5 V)	T.B.D.	528 mW (50 MHz @ 3.3 V)	416 mW (40 MHz @ 3.3 V)	330 mW (40 MHz @ 3.3 V) 272 mW (33 MHz @ 3.3 V)	218 mW (33 MHz @ 3.3 V)
Package	176-pin LQFP (24 × 24 mm) 240-pin FBGA (16 × 16 mm)	144-pin LQFP (20 × 20 mm) 161-pin FBGA (13 × 13 mm)	144-pin LQFP (20 × 20 mm) 161-pin FBGA (13 × 13 mm)	100-pin LQFP (14 × 14 mm)	144-pin LQFP (20 × 20 mm) 157-pin FBGA (14 × 14 mm)	100-pin LQFP (14 × 14 mm)

* : Only Y products have an on-chip I²C interface.

Note : 1.35 V to 1.65 V : @ 10 MHz to 133 MHz
1.40 V to 1.65 V : @ 10 MHz to 150 MHz

Application examples

MFP (Multifunction printer)

Multi Function Printer
V850E/ME2

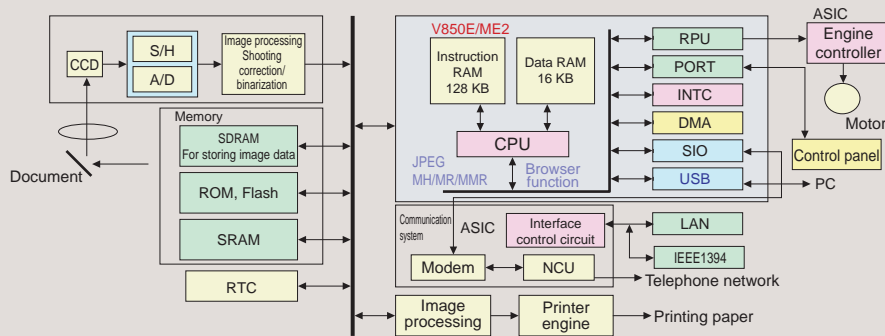

Thermal printer

Thermal Printer
V850E/MA3

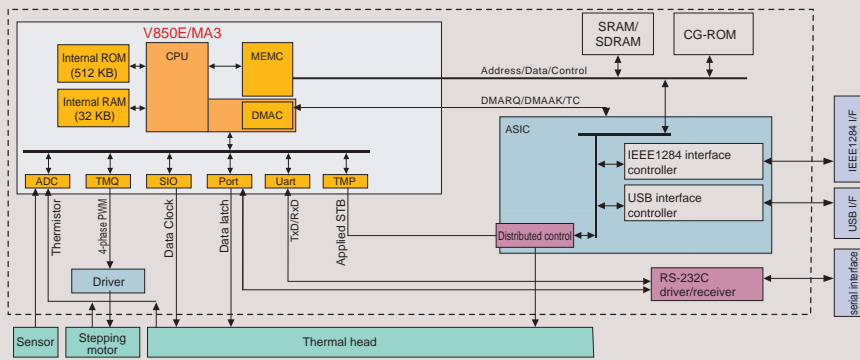

DVD player

DVD Player
V850E/MA2

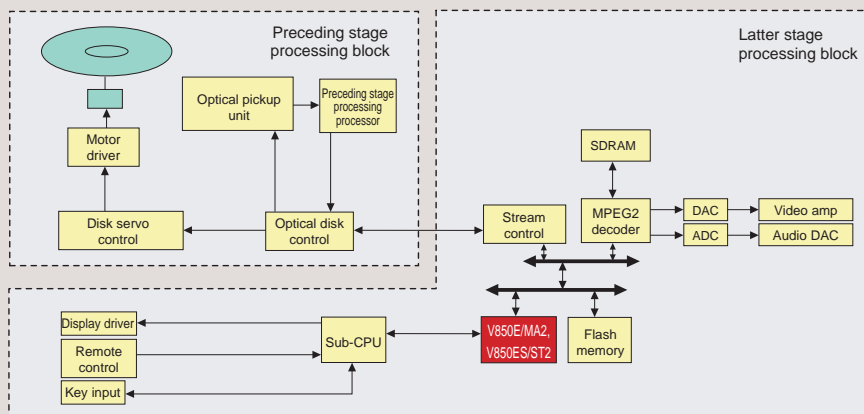

Fax machine

FAX Machine
V850E/MS1

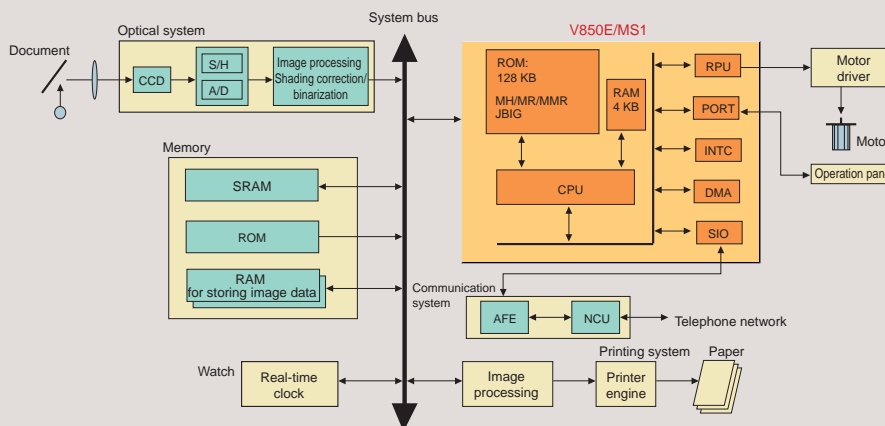

ASSP Lineup (1)

Field-specific lineups

In mass production

Under development

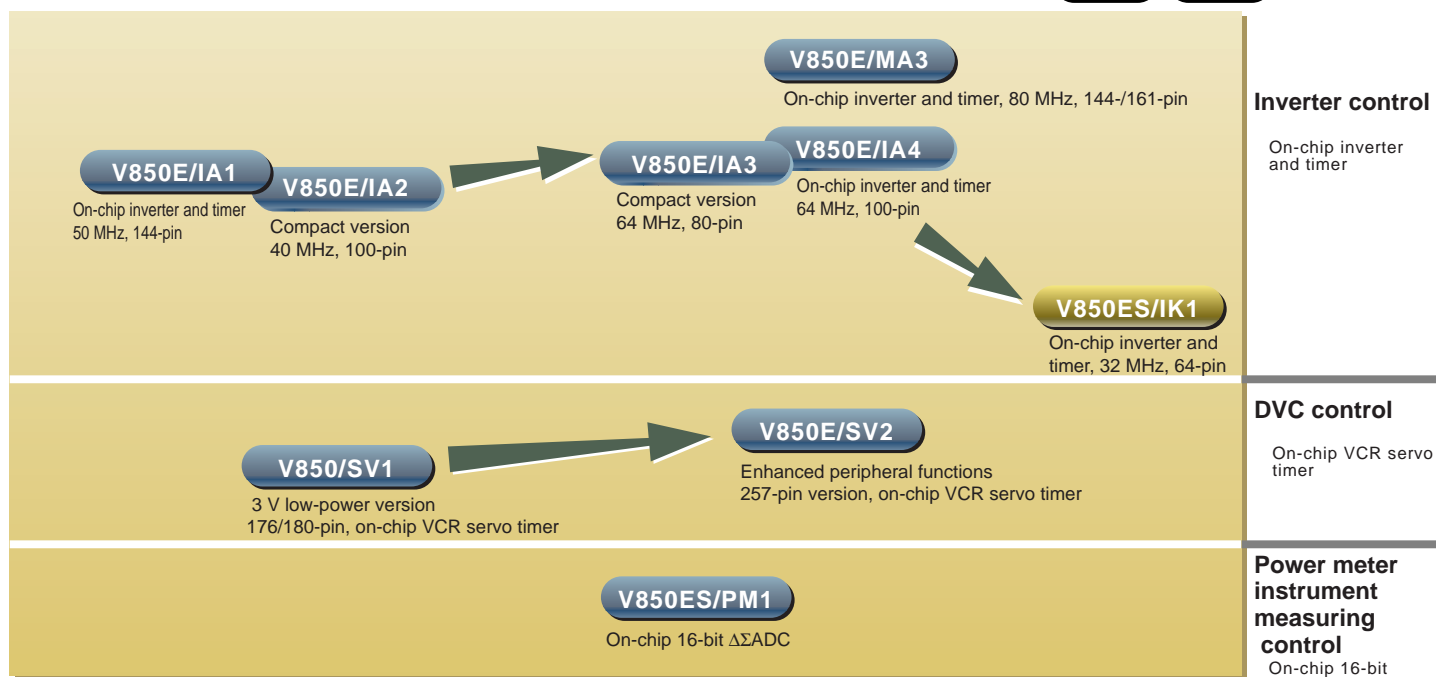

Features

V850E/IA3, IA4

- For inverter control
- 82 MIPS @ 64 MHz, internal 2.5 V/external 5 V operation
- On-chip 6-phase sinusoidal PWM timer, on-chip operational amplifier/comparator, on-chip high-speed A/D
- On-chip debugging function (IA4 only)
- ROM/RAM: 256 KB/12 KB, 128 KB/6 KB (mask ROM version only)
- 80-pin QFP (IA3), 100-pin LQFP/100-pin QFP (IA4)

V850E/SV2

- For camcorders (incl. DVC)
- 32-bit servo timer ideal for camcorder control, boundary scan function, on-chip debugging function, and many other on-chip peripheral functions
- 55 MIPS @ 40.5 MHz, 2.5 V low-voltage/high-speed operation
- Large-capacity memory (ROM/RAM: 512 KB/24 KB)
- Internal single-power-supply flash
- Compact high-pin-count 257-pin FBGA (14×14 mm, 0.65 mm pitch)

V850ES/IK1

- For inverter control
- 41 MIPS @ 32 MHz, 4.5 V to 5.5 V (on-chip regulator)
- On-chip 6-phase sinusoidal PWM timer, POC/LVI, and clock monitor functions
- ROM/RAM: 128 KB/6 KB, 64 KB/4 KB
- 64-pin LQFP

V850ES/PM1

- For power meter control
- On-chip high-resolution, high-accuracy 16-bit $\Delta\Sigma$ /D converter
- ROM/RAM: 128 KB/10 KB, ROM-less/10 KB
- 29 MIPS @ 20 MHz, 3.0 V to 3.6 V operation
- 100-pin LQFP

Product specifications

Item	V850E/IA1	V850E/IA2	V850E/IA3	V850E/IA4	V850ES/IK1
CPU core	V850E1	V850E1	V850E1	V850E1	V850ES
Performance	67 MIPS (@ 50 MHz)	54 MIPS (@ 40 MHz)	82 MIPS (@ 64 MHz)	82 MIPS (@ 64 MHz)	41 MIPS (@ 32 MHz)
Maximum operating frequency	50 MHz	40 MHz	64 MHz	64 MHz	32 MHz
Internal flash memory	256 KB	128 KB	256 KB	256 KB	128 KB
Internal mask ROM	256 KB	128 KB	128 KB	256 KB/128 KB	128 KB/64 KB
Internal RAM	10 KB	6 KB	12 KB/6 KB	12 KB/6 KB	6 KB/4 KB
Power supply voltage	3.0 V to 3.6 V (internal) 4.5 V to 5.5 V (external)	4.5 V to 5.5 V	2.3 V to 2.7 V (internal) 4.5 V to 5.5 V (external)	2.3 V to 2.7 V (internal) 4.5 V to 5.5 V (external)	3.5 V to 5.5 V
External bus	Address: Multiplexed Data: 8/16 bits	Address: Multiplexed Data: 8/16 bits	-	-	-
Timer/counter	16-bit × 8 ch	16-bit × 7 ch	16-bit t × 8 ch WDT × 1 ch	16-bit × 9 ch WDT × 1 ch	16-bit × 7 ch WDT × 1 ch
Serial interface	CSI × 2ch, UART × 3ch	CSI × 1 ch, CSI/UART × 1 ch UART × 1 ch	CSI × 1 ch, CSI/UART × 1 ch UART × 1 ch	CSI × 1 ch, CSI/UART × 1 ch UART × 1 ch	CSI × 1 ch, UART × 2 ch
A/D converter	10-bit × (8 ch + 8 ch)	10-bit × (6 ch + 8 ch)	10-bit × (4 ch + 2 ch), 8/10-bit × 6 ch	10-bit × (4 ch + 4 ch), 8/10-bit × 8 ch	10-bit × (4 ch + 4 ch)
D/A converter	-	-	-	-	-
DMA controller	4 ch	4 ch	4 ch	4 ch	-
Other peripheral functions	FCAN × 1 ch	-	ROM correction function operational amplifier, comparator, pull-up function	On-chip debugging and ROM correction functions Operational amplifier, comparator, pull-up function	ROM correction function, pull-up function, POC/LVI, clock monitor function
I/O	83	53	50	64	39
Power consumption (mask ROM version, Typ.)	630 mW (50 MHz @ 3.3 V)	440 mW (40 MHz @ 5 V)	175 mW (64 MHz @ 2.5 V)	175 mW (64 MHz @ 2.5 V)	T.B.D.
Package	144-pin LQFP (20 × 20 mm)	100-pin LQFP (14 × 14 mm) 100-pin QFP (14 × 20 mm)	80-pin QFP (14 × 14 mm)	100-pin QFP (14 × 20 mm) 100-pin LQFP (14 × 14 mm)	64-pin LQFP (14 × 14 mm)

Application examples

Air conditioner

Air Conditioner V850E/IA4

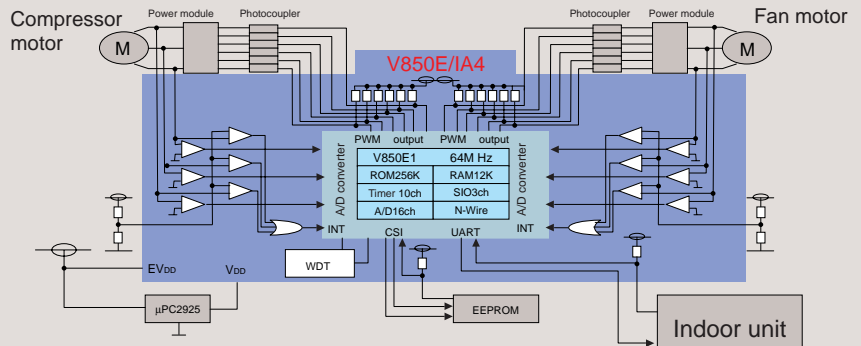

DVC

Digital Video Camera V850E/SV2

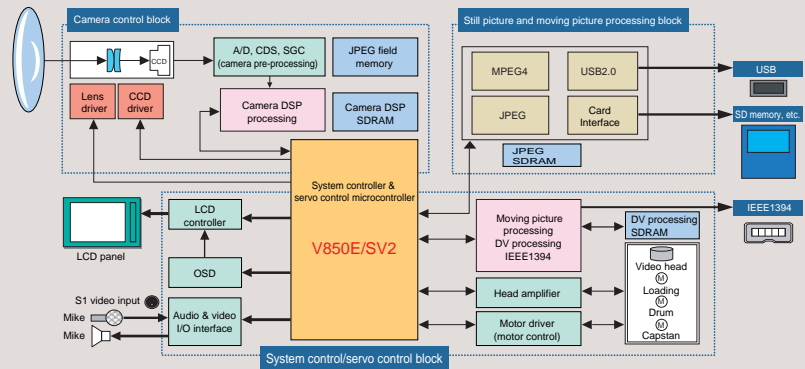

Power meter

Power Meter V850ES/PM1

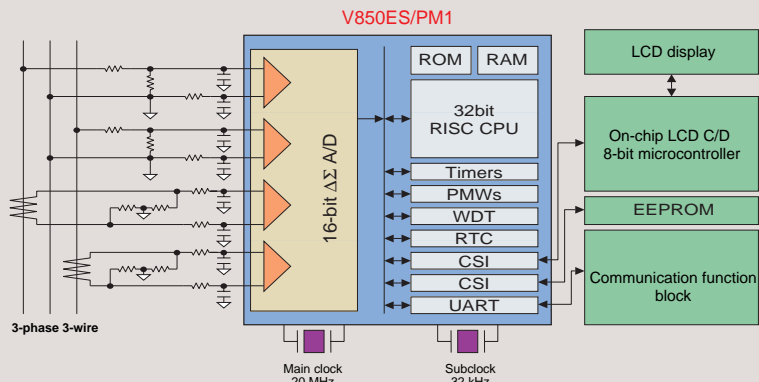

Item	V850/SV1	V850E/SV2	V850ES/PM1
CPU core	V850	V850E1	V850ES
Performance	23 MIPS (@ 20 MHz)	55 MIPS (@ 40.5 MHz)	29 MIPS (@ 20 MHz)
Maximum operating frequency	20 MHz	40.5 MHz	20 MHz
Internal flash memory	384 KB/256 KB	512 KB	-
Internal mask ROM	384 KB/256 KB/192 KB	512 KB	128 KB/ROM-less
Internal RAM	16 KB/8 KB	24 KB	10 KB
Power supply voltage	3.1 V to 3.6 V @ 20 MHz 2.7 V to 3.6 V @ 16 MHz	2.3 V to 2.7 V (internal) 2.7 V to 3.6 V (external)	3.0 V to 3.6 V @ 20 MHz, 2.7 V to 3.6 V @ 10 MHz, 2.2 to 3.6 V @ 32.768 kHz
External bus	Address: Multiplexed Data: 16 bits	Address: Multiplexed/separate Data: 8/16 bits	Address: Separate Data: 8/16 bits
Timer/counter	24-bit × 2 ch, 16-bit × 2 ch 8-bit × 8ch, WDT × 1 ch, watch timer × 1 ch	32-bit × 1 ch, 16-bit × 12 ch 8-bit × 12 ch, WDT × 1 ch	16-bit × 6 ch, 8-bit × 2 ch WDT × 1 ch
Serial interface	CSI × 1 ch, CSI/UART × 2 ch CSI/I ² C × 2 ch*	CSI × 5 ch, CSI/UART × 1 ch, UART × 1 ch, I ² C × 1 ch*	CSI × 2 ch, UART × 2 ch
A/D converter	10-bit × 16 ch	10-bit × 24 ch	16-bit ΔΣ × 6 ch
D/A converter	-	-	-
DMA controller	6 ch (internal RAM-on-chip peripheral I/O)	4 ch	-
Other peripheral functions	ROM correction function, dedicated PWM output × 4, Hsync/Vsync separation circuit	On-chip debugging function, boundary scan function ROM correction function, dedicated PWM output: 5 ch	ROM correction function, dedicated PWM output: 4 ch Real-time counter (watch function)
I/O	151	195	81
Power consumption (mask ROM version, Typ.)	82 mW (20 MHz @ 3.3 V)	134 mW (40.5 MHz @ 2.5 V)	80 mW (20 MHz @ 3.3 V)
Package	176-pin LQFP (24 × 24 mm) 180-pin FBGA (13 × 13 mm)	257-pin FBGA (14 × 14 mm)	100-pin LQFP (14 × 14 mm)

* : Only Y products have an on-chip I²C interface.

Product Lineup

ASSP Lineup (2)

Field-specific lineups

In mass production Under development Under planning

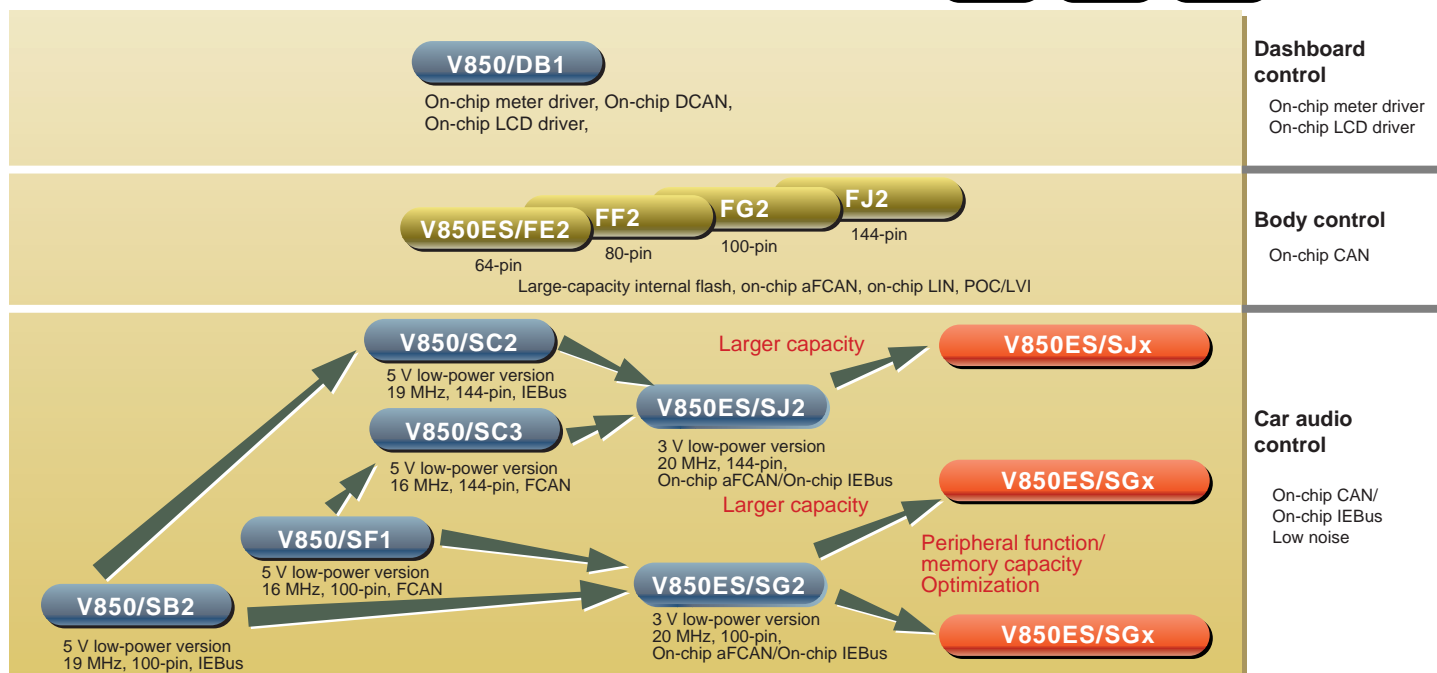

Features

V850/DB1

- For automotive electronics (body control applications)
- ROM/RAM : 128 KB/6 KB
- On-chip DCAN controller (2 ch max.)
- 18 MIPS @ 16 MHz, 4.0 to 5.5 V operation
- 128-pin QFP

V850ES/FE2, FF2, FG2, FJ2

- For automotive electronics (body control applications)
- On-chip large-capacity single-power-supply flash memory
- ROM/RAM: 512 KB/20 KB, 384 KB/16 KB, 256 KB/12 KB, 128 KB/6 KB
- On-chip aFCAN controller (4 ch max.), LIN function compatible UART, POC/LVI
- 29 MIPS @ 20 MHz, 4.0 to 5.5 V operation
- 64-pin TQFP (FE2)/80-pin TQFP (FF2)/100-pin LQFP (FG2)/144-pin LQFP (FJ2)

V850ES/SG2, SJ2

- For car audio
- On-chip large-capacity single-power-supply flash memory
- ROM/RAM : 640 KB/48 KB, 512 KB/40 KB, 384 KB/32 KB, 256 KB/24 KB (SG2 only)
- On-chip IEBus controller (1 ch), on-chip aFCAN controller (2 ch max.)
- 29 MIPS @ 20 MHz, 2.85 to 3.6 V operation
- 5 V withstand voltage ports incorporated, and 5 V output is possible by setting the N-ch open-drain output
- On-chip debugging function
- 100-pin LQFP/100-pin QFP (SG2), 144-pin LQFP (SJ2)

V850/SF1

- For car audio
- Low EMI noise
- On-chip FCAN controller (2 ch max.)
- ROM/RAM: 256 KB/16 KB, 128 KB/12 KB
- 100-pin LQFP/100-pin QFP

Product specifications

Item	V850ES/Fx2			
	FE2	FF2	FG2	FJ2
CPU core	V850ES			
Performance	29 MIPS (@ 20 MHz)			
Maximum operating frequency	20 MHz			
Internal flash memory	128 KB/64 KB	256 KB/128 KB	384 KB/256 KB/128 KB	512 KB
Internal mask ROM	128 KB/64 KB	256 KB/128 KB	256 KB/128 KB	-
Internal RAM	6 KB/4 KB	12 KB/6 KB	16 KB/12 KB/6 KB	20 KB
Power supply voltage	4.0 V to 5.5 V			
External bus	Address: Multiplexed bus Data: 8/16 bits			
Timer/counter	16-bit × 6 ch WDT × 1 ch, watch timer × 1 ch		16-bit × 7 ch WDT × 1 ch, watch timer × 1 ch	
Serial interface	CSI × 2 ch, LIN-compatible UART × 2 ch		CSI × 3 ch, LIN-compatible UART × 3 ch	
A/D converter	10-bit × 10 ch		10-bit × 16 ch	
D/A converter	-		-	
DMA controller	4 ch			
Other peripheral functions	POC/LVI function, clock monitor function, RAM hold flag			
I/O	51	67	84	128
Power consumption (mask ROM version, Typ.)	155 mW (20 MHz @ 5 V)		200 mW (20 MHz @ 5 V)	
Package	64-pin TQFP (10 × 10 mm)	80-pin TQFP (12 × 12 mm)	100-pin LQFP (14 × 14 mm)	144-pin LQFP (20 × 20 mm)

V850/SB2

- Low EMI noise
- Large-capacity memory and large memory selection
- ROM/RAM: 512K/24KB, 384KB/24KB, 256KB/16KB, 128KB/8KB
- On-chip IEBus controller (1 ch)
- 100-pin QFP/100-pin LQFP

V850/SC2,SC3

- Low EMI noise
- Large-capacity memory (ROM/RAM: 512 KB/24 KB)
- Enhanced peripheral functions for SB1
- On-chip IEBus controller (V850/SC2 : 1 ch),
On-chip FCAN controller (V850/SC3 : 2 ch max.)
- 144-pin LQFP

Application examples

Dashboard

Dashboard V850ES/Fx2

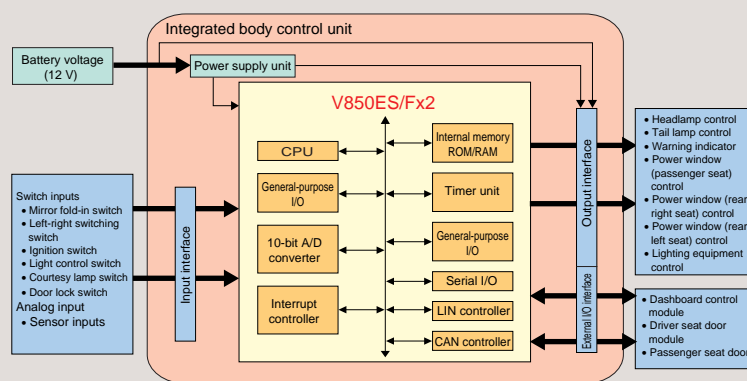

Car audio

Car Audio V850/SF1

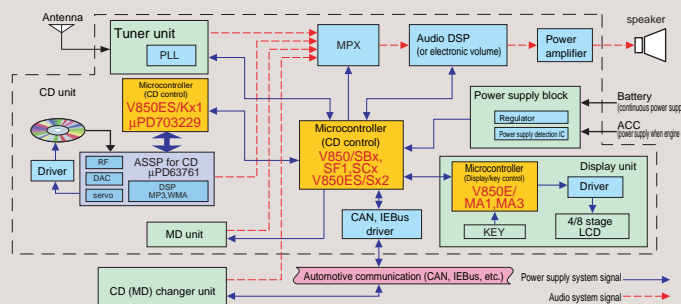

Item	V850/SB2	V850/SCx		V850/SF1	V850/DB1
		SC2	SC3		
CPU core	V850	V850		V850	V850
Performance	22 MIPS (@ 19 MHz)	21 MIPS (@ 19 MHz)	18MIPS (@ 16 MHz)	18 MIPS (@ 16 MHz)	18 MIPS (@ 16MHz)
Maximum operating frequency	19 MHz/13 MHz (main clock) 32.768 kHz (subclock)	19 MHz (main clock) 32.768 kHz (subclock)	16 MHz (main clock) 32.768 kHz (subclock)	16 MHz	16 MHz
Internal flash memory	512 KB/384 KB/256 KB	512 KB		256 KB	128 KB
Internal mask ROM	512 KB/384 KB/256 KB/128 KB	512 KB		256 KB/128 KB	128 KB
Internal RAM	24 KB/16 KB/8 KB	24 KB		16 KB/12 KB	6 KB
Power supply voltage	4.0 V to 5.5 V	3.5 V to 5.5 V (mask version) 4.0 V to 5.5 V (flash version)		3.5 V to 5.5 V (mask version), 4.0 V to 5.5 V (flash version) 3.5 V to 5.5 V @ 32.768 kHz	4.0 V to 5.5 V
External bus	Address: Multiplexed/separate Data: 16-bits	Address: Multiplexed/separate Data: 16-bits	Address: Multiplexed Data: 16-bit	Address: Multiplexed Data: 16-bit	-
Timer/counter	16-bit × 2 ch, 8-bit × 6 ch WDT × 1 ch, watch timer × 1 ch	16-bit × 10ch WDT × 1 ch, watch timer × 1 ch		16-bit × 8ch WDT × 1ch, watch timer × 1 ch	16-bit × 3 ch, 8-bit × 2 ch WDT × 1 ch, watch timer × 1 ch
Serial interface	CSI × 1 ch, CSI/UART × 2 ch CSI/I ² C × 2 ch	CSI × 2 ch, CSI/UART × 2 ch UART × 2 ch, CSI/I ² C × 2 ch		CSI × 1 ch, CSI/UART × 2 ch CSI/I ² C × 1 ch	CSI × 3 ch, UART × 2 ch
A/D converter	-	10-bit × 12 ch		10-bit × 12 ch	10-bit × 8 ch
D/A converter	-	-		-	-
DMA controller	6 ch (internal RAM-on-chip peripheral I/O)	6 ch (internal RAM-on-chip peripheral I/O)		6 ch (internal RAM-on-chip peripheral I/O)	-
Other peripheral functions	IEBus × 1 ch ROM correction function	IEBus × 1 ch ROM correction function	FCAN × 2 ch ROM correction function	FCAN × 2 ch, ROM correction function	meter control/PWM (8-bit) × 24 ch DCAN × 2 ch (flash version)/1 ch (mask version)
I/O	83	124		84	107
Power consumption (mask ROM version, Typ.)	125 mW (19 MHz @ 5 V)	120 mW (19 MHz @ 5V)	110 mW (16 MHz @ 5 V)	75 mW (16 MHz @ 5 V)	120mW (16 MHz @ 5V)
Package	100-pin LQFP (14 × 14 mm) 100-pin QFP (14 × 20 mm)	144-pin LQFP (20 × 20 mm)		100-pin LQFP (14 × 14 mm) 100-pin QFP (14 × 20 mm)	128-pin QFP (20 × 20 mm)

Product Lineup

Memory Lineup

Flash memory version

Mask ROM version

Mask ROM/flash memory version

640K											SJ2* SJ2 SG2* SG2
512K						MA3*	FJ2*	SV2 SC3 SC2 SC1 SB2 SB1	MA3* MA3	SJ2* SG2*	
384K						SV1 FG2* FJ2*		SB2 SB1	SJ2* SJ2 SG2 3229Y		
256K		SV1 SA1 V853	MA1 IA1	IA4 IA3 KF1+* KF1* FJ2* FG2* FF2*	MA3* SA3 SA2 KJ1+* KJ1* KG1+* KG1* SV1 SF1 SB2 SB1			SG2* MA3*			
192K			SV1								
128K	MA1 MS1 KE1+* KE1 SA1 V853	IK1* IA4 IA3 IA2 KJ1+* KJ1 KG1+* KG1 KF1+* KF1 DB1 FE2* FF2* FG2*	SB2 SB1 SA2	MA1 PM1	SF1						
96K	MS1 KG1 KF1 V853	KJ1									
64K	IK1* KF1 KG1 SA1 FE2*										
ROM less	MS1 MS2 MA1 MA2			PM1		ME2 Instruction RAM : 128KB					ST2*
ROM Size (bytes)	4K	6K	8K	10K	12K	16K	20K	24K	32K	40K	48K
	RAM size (bytes)										

* : Under development

Package Lineup



**121
PIN**

No. of pins	121 pins
Type	FBGA (F1)
Size	12×12 mm
Pitch	0.8 mm
Thickness	1.13 mm
Mounted products	SA1, SA3

**64
PIN**

No. of pins	64 pins
Type	LQFP (GB)
Size	10×10 mm
Pitch	0.5 mm
Thickness	1.4 mm
Mounted products	KE1, KE1+

**161
PIN**

No. of pins	161 pins
Type	FBGA (F1)
Size	13×13 mm
Pitch	0.8 mm
Thickness	1.13 mm
Mounted products	MA1, MA3

**64
PIN**

No. of pins	64 pins
Type	TQFP (GB)
Size	10×10 mm
Pitch	0.5 mm
Thickness	1.0 mm
Mounted products	FE2

**100
PIN**

No. of pins	100 pins
Type	LQFP (GC)
Size	14×14 mm
Pitch	0.5 mm
Thickness	1.4 mm
Mounted products	KG1, KG1+, SA1, SB1, SB2, SF1, SG2, PM1, FG2, MS2, MA2, IA2, IA4, V853, μPD70F3229Y

**180
PIN**

No. of pins	180 pins
Type	FBGA (F1)
Size	13×13 mm
Pitch	0.8 mm
Thickness	1.13 mm
Mounted products	SV1

**64
PIN**

No. of pins	64 pins
Type	TQFP (GK)
Size	12×12 mm
Pitch	0.65 mm
Thickness	1.0 mm
Mounted products	KE1, KE1+

**120
PIN**

No. of pins	120 pins
Type	TQFP (GC)
Size	14×14 mm
Pitch	0.4 mm
Thickness	1.0 mm
Mounted products	ST2

**157
PIN**

No. of pins	157 pins
Type	FBGA (F1)
Size	14×14 mm
Pitch	0.8 mm
Thickness	0.96 mm
Mounted products	MS1

**80
PIN**

No. of pins	80 pins
Type	TQFP (GK)
Size	12×12 mm
Pitch	0.5 mm
Thickness	1.0 mm
Mounted products	KF1, KF1+, FF2

**100
PIN**

No. of pins	100 pins
Type	QFP (GF)
Size	14×20 mm
Pitch	0.65 mm
Thickness	1.4 mm
Mounted products	KG1, KG1+, SB1, SB2, SF1, SG2, IA2, IA4

**257
PIN**

No. of pins	257 pins
Type	FBGA (F1)
Size	14×14 mm
Pitch	0.65 mm
Thickness	1.13 mm
Mounted products	SV2

**64
PIN**

No. of pins	64 pins
Type	LQFP (GC)
Size	14×14 mm
Pitch	0.8 mm
Thickness	1.4 mm
Mounted products	IK1

**128
PIN**

No. of pins	128 pins
Type	QFP (GJ)
Size	20×20 mm
Pitch	0.5 mm
Thickness	1.4 mm
Mounted products	DB1

**240
PIN**

No. of pins	240 pins
Type	FBGA (F1)
Size	16×16 mm
Pitch	0.8 mm
Thickness	1.13 mm
Mounted products	ME2

**80
PIN**

No. of pins	80 pins
Type	QFP (GC)
Size	14×14 mm
Pitch	0.65 mm
Thickness	1.4 mm
Mounted products	KF1, KF1+, IA3

**144
PIN**

No. of pins	144 pins
Type	LQFP (GJ)
Size	20×20 mm
Pitch	0.5 mm
Thickness	1.4 mm
Mounted products	KJ1, KJ1+, SC1, SC2, SC3, SJ2, ST2, FJ2, MS1, MA1, MA3, IA1

**100
PIN**

No. of pins	100 pins
Type	TQFP (GC)
Size	14×14 mm
Pitch	0.5 mm
Thickness	1.0 mm
Mounted products	SA2

**176
PIN**

No. of pins	176 pins
Type	LQFP (GM)
Size	24×24 mm
Pitch	0.5 mm
Thickness	1.4 mm
Mounted products	SV1, ME2

CPU Roadmap

Performance range of 20 to over 300 MIPS with single instruction set

- Utilization of existing software resources
- Maintenance of real-time performance
- Pursuit of low power consumption

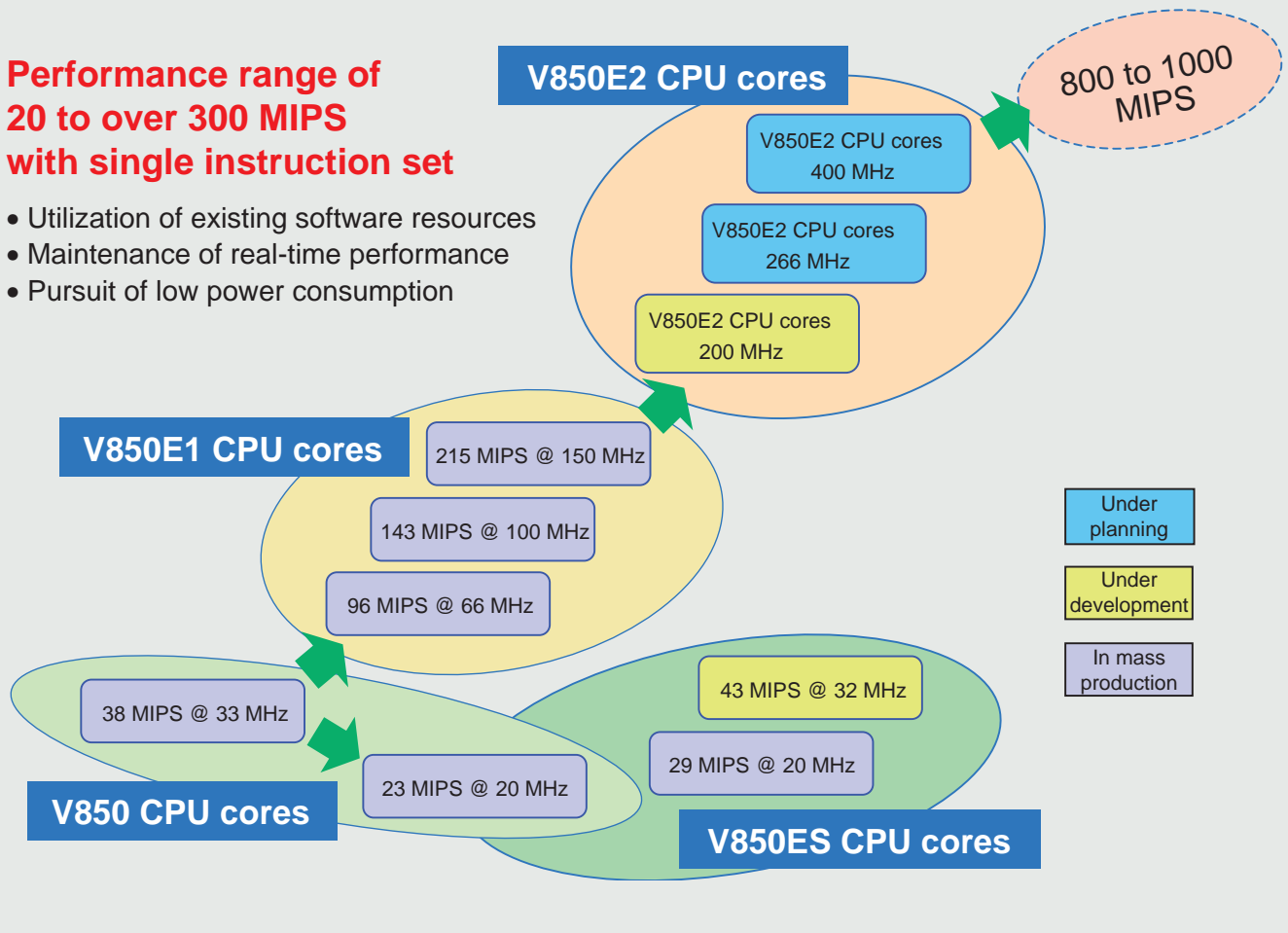

CPU Core Function Comparison

CPU Core Function	V850	V850ES	V850E1	V850E2
Maximum operating frequency	20/33 MHz	20/32 MHz	66⇒100⇒150 MHz	200⇒266⇒400 MHz
Instructions	47	80	80	89
Maximum program memory space	16 MB	16 MB	64 MB	512 MB (internal 128 MB)
Maximum data memory space	16 MB	16 MB	256 MB	4 GB
Higher performance	5-stage pipeline Harvard architecture	Improved pipeline <ul style="list-style-type: none"> • Non-blocking load/store instructions - Parallel instruction execution (instruction execution in internal ROM) • Addition of branching/load pipe • Shift to 3-operand manipulations in 1 slot 		<ul style="list-style-type: none"> • 7-stage pipeline Simultaneous execution of 2 instructions with 3 pipelines that can operate independently from each other
High code efficiency	2-byte instructions CISC instructions	Addition of C language compatible instructions (Switch instruction, Callt instruction, data conversion instruction, Prepare/Dispose instruction)		<ul style="list-style-type: none"> 32-bit relative branch instruction 3-operand instruction Sum-of-products instruction Bit search instruction
Multiplier	16×16 bits⇒32 bit multiplication	16×16 bits⇒32-bit operation 32×32 bits⇒64-bit operation (32-bit multiply instruction support)	16×16 bits⇒32-bit operation 32×32 bits⇒64-bit operation	
Interrupt responsiveness	11 to 18 clocks	4 to 10 clocks		

System LSI Support

◆ Use of same development methods for standard V850 Series products, ASIC microcontrollers

- ➔ Quick market introduction of standard products
- ➔ System optimization through shift to system LSIs

◆ CPU core development considering system LSIs

- ➔ Release of cores that support on-chip debugging
- ➔ 2-stage structure consisting of 32-bit sync system bus & 16-bit async peripheral function bus
- ➔ Large choice of peripheral function macros

◆ Many supported processes and large range of required performance, and power consumption

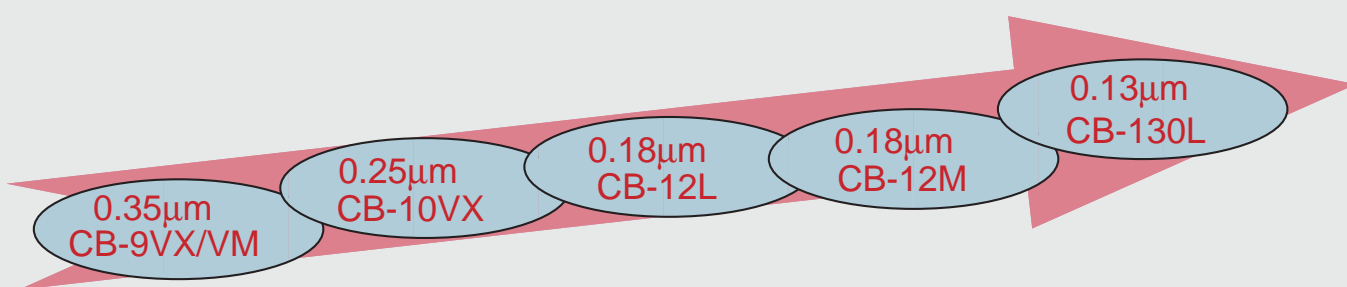

● V850E1 system configuration example

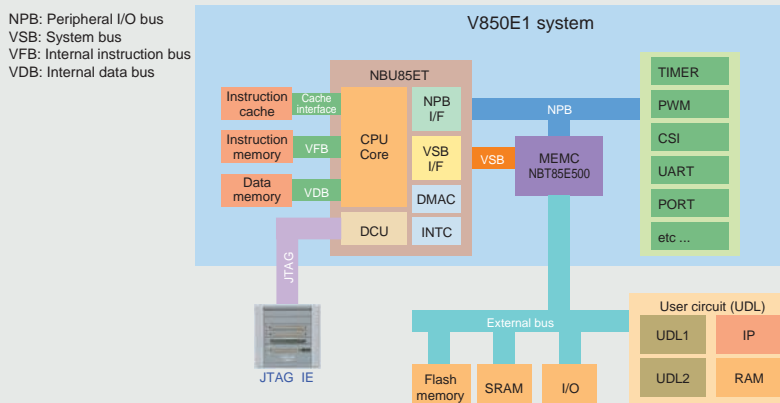

● V850E2 system configuration example

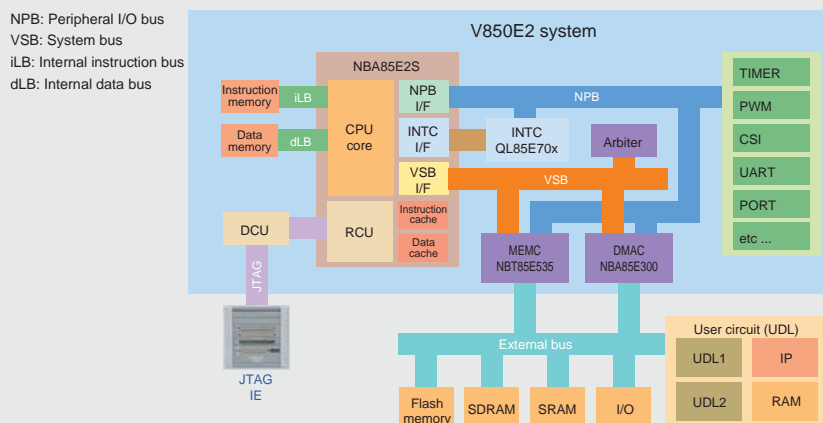

V850 Series Common Architecture

The V850 Series, which consists of single-chip RISC microcontrollers that use an architecture optimized for embedding, has the following features.

- 5-stage pipeline processing
- Harvard architecture
- 32 general-purpose registers
- Simple addressing
- 2-byte basic instruction set
- Support of CISC-like instructions
- Multi-status flags
- DSP function
- 32-bit barrel shifter

5-stage pipeline processing

The V850 Series uses a 5-stage pipeline structure (5 stages from instruction fetch to writeback) that supports simultaneous processing of 5 instructions, thus enabling the execution of almost all instructions in just one clock.

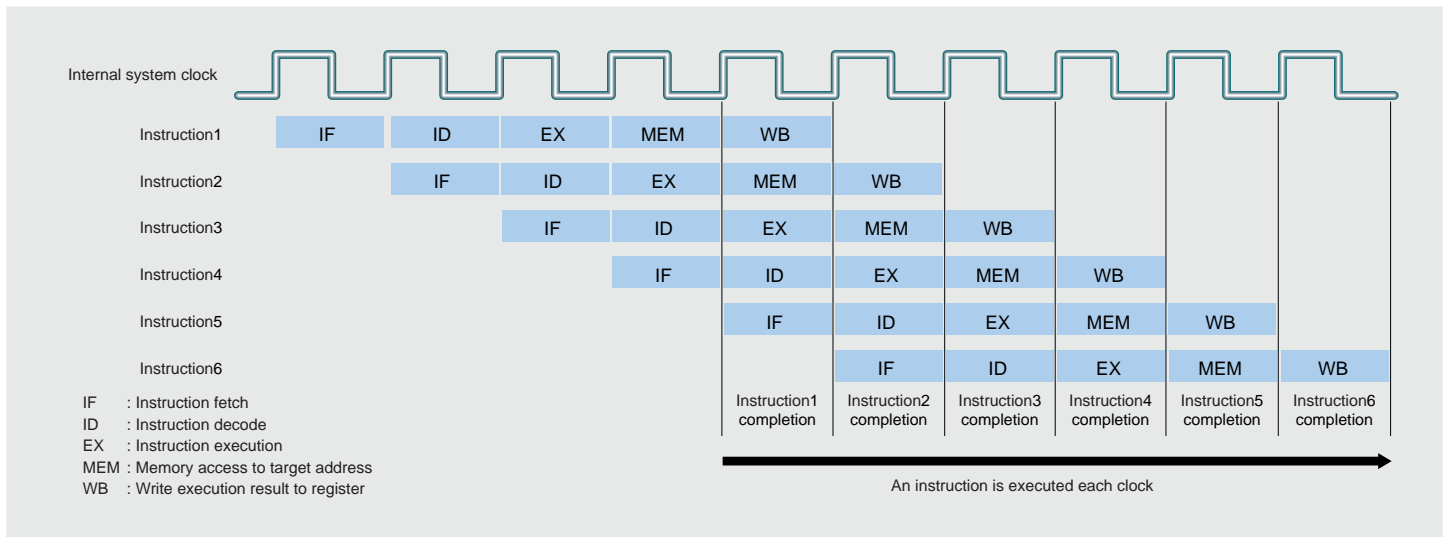

Harvard architecture

The V850 Series uses the Harvard architecture, which is designed so that the instruction bus and data bus can operate completely independently from each other, thereby preventing pipeline operation problems and ensuring efficient instruction execution.

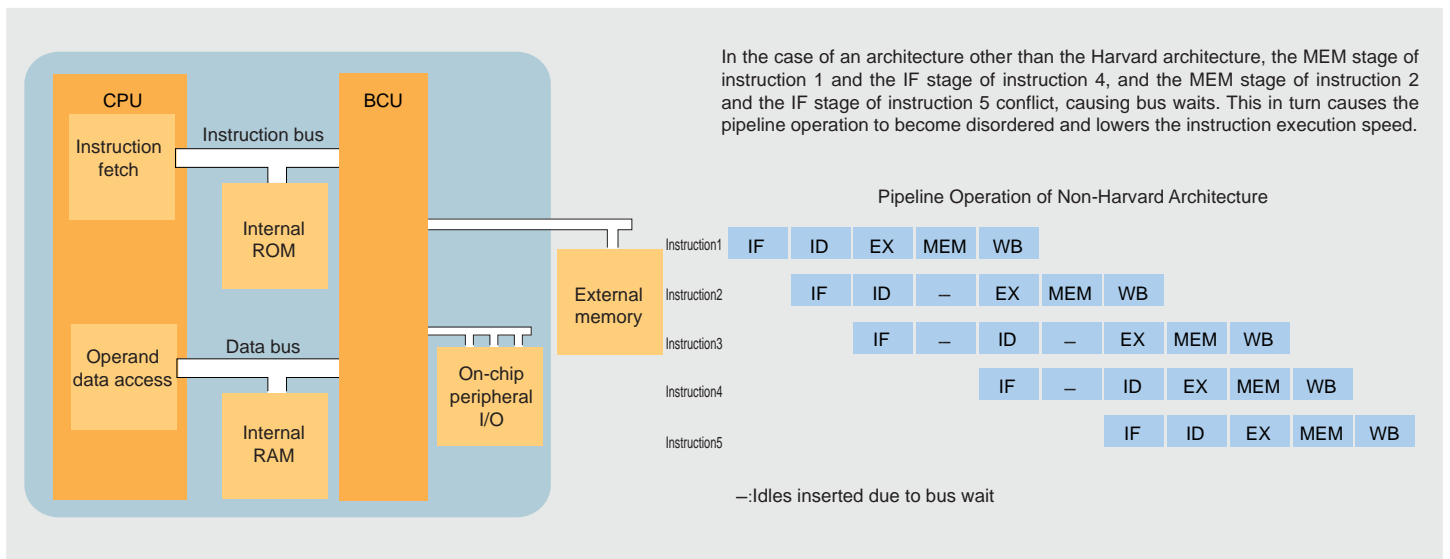

32 general-purpose registers

The V850 Series provides 32 general-purpose registers. Along with a hardware environment that is ideal for program execution, the development environment, including compilers, exploits these 32 registers to achieve program generation with superior code efficiency and execution performance.

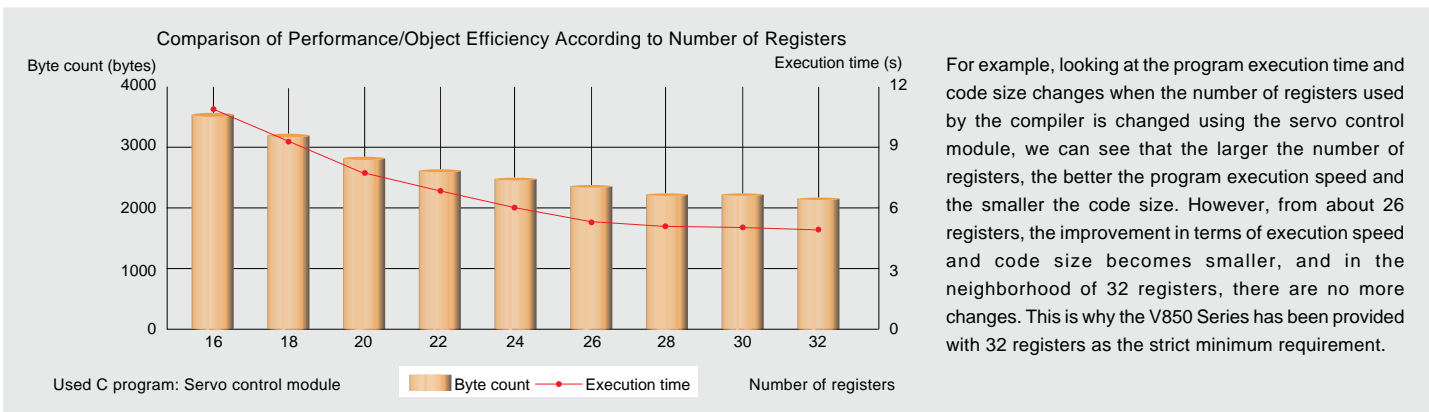

For example, looking at the program execution time and code size changes when the number of registers used by the compiler is changed using the servo control module, we can see that the larger the number of registers, the better the program execution speed and the smaller the code size. However, from about 26 registers, the improvement in terms of execution speed and code size becomes smaller, and in the neighborhood of 32 registers, there are no more changes. This is why the V850 Series has been provided with 32 registers as the strict minimum requirement.

Software register bank

The number of registers can be selected from among 22, 26, and 32 as a compiler option to efficiently execute application programs. Unused registers can be used as a software register bank for which save and restore processing is not required during interrupt servicing or task switching, which increases the processing speed.

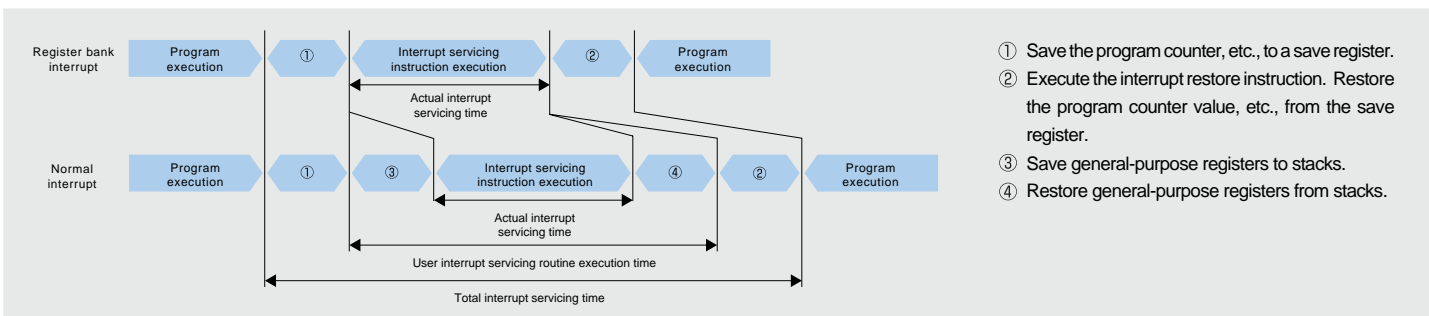

General-purpose register configuration

No.	Name	Application	Operation
r0	Zero Register		
r1	Reserved for Address Generation		
r2			
r3	Stack Pointer(SP)		
r4	Global Pointer(GP)		
r5	Text Pointer(TP)		
r6			
r7			
r8			
r9			
r10			
r11			
r12			
r13			
r14			
r15			
r16			
r17			
r18			
r19			
r20			
r21			
r22			
r23			
r24			
r25			
r26			
r27			
r28			
r29			
r30	Element Pointer(EP)		
r31	Link Pointer(LP)		
PC	Program Counter		

Name	Application	Operation
r0	Zero register	Always holds "0"
r1	Assembler reservation	Used as working register for address generation
r2	Address/data variable register (If real-time OS being used does not use r2)	
r3	Stack pointer	Used for stack frame generation during function call
r4	Global pointer	Used when accessing global variables in the data area
r5	Text pointer	Used as register for specifying the beginning of the text area (program code allocation)
r6-r29	Address/data variable register	
r30	Element pointer	Used as base pointer for address generation during memory access
r31	Link pointer	Used during function call by compiler
PC	Program counter	Holds instruction addresses during program execution

System register configuration

No.	System Register Name	Operand Specification		Application
		LDSR	STSR	
0	EIPC	○	○	Register for saving status during interrupt
1	EIPSW	○	○	
2	FEPC	○	○	Register for saving status during NMI
3	FEPSW	○	○	
4	ECR	×	○	Interrupt source register
5	PSW	○	○	Program status word
16	CTPC	○	○	Register for saving status during CALLT execution
17	CTPSW	○	○	
18	DBPC	○	○	Register for saving status during exception/debug trap
19	DBPSW	○	○	
20	CTBP	○	○	CALLT base pointer
6-15, 21-31	Reserved	×	×	

Supported by other than V850 CPU core products

× : Access prohibited LDSR: Instruction to load general-purpose register contents to system register
 ○ : Access enabled STSR: Instruction to store system register contents to general-purpose register

Simple addressing

The increased amount of address calculations in the CPU in the case of complex addressing causes disturbances in the pipeline operation. As a result, address calculation becomes a bottleneck for pipeline processing and raising the frequency to increase the performance becomes difficult. The V850 Series avoids this problem by supporting only simple addressing.

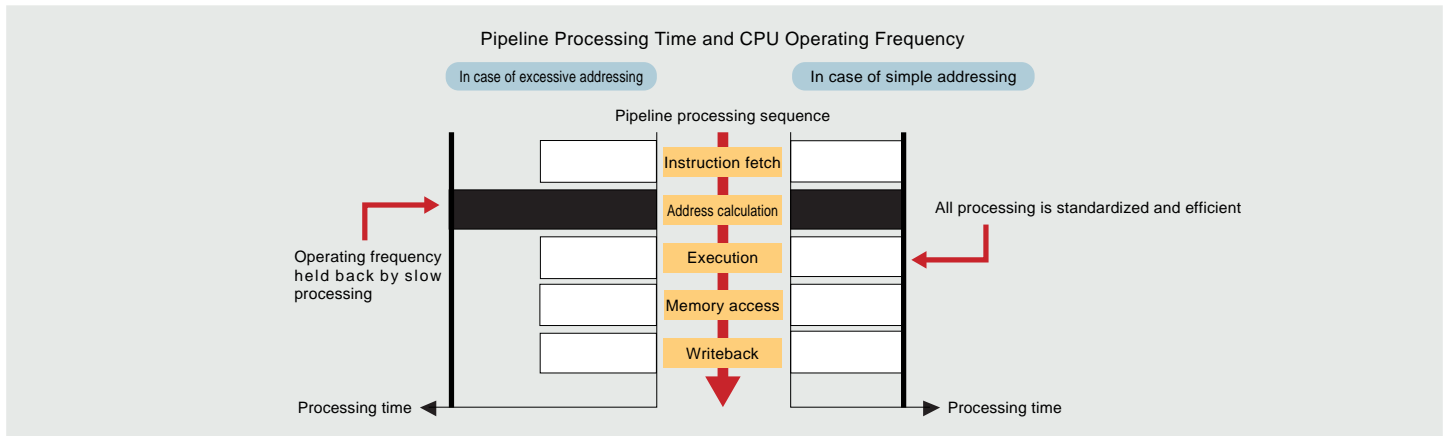

Addressing mode

Instruction addresses

Relative addressing (PC dependent)

Add 9 signed bits or 22 signed bits of data of the instruction code to the program counter.

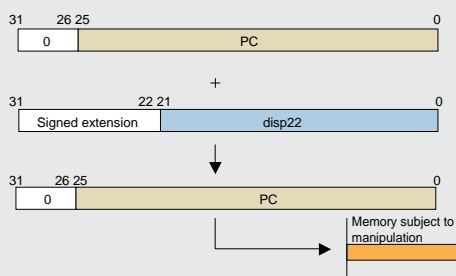

Register addressing (register indirect)

Transfer the contents of the general-purpose register specified by the instruction (reg1) to the program counter (PC).

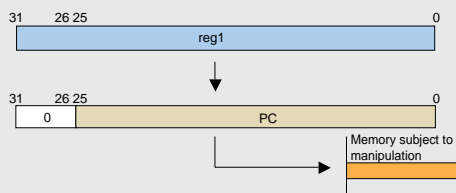

Operand addresses

Register addressing

Addressing that accesses the general-purpose register specified by the general-purpose specification field or a system register as an operand.

Immediate addressing

Addressing of 5-bit data or 16-bit data for manipulation in the instruction code.

Based addressing

Addressing that accesses memory, with the sum of the contents of the general-purpose register (reg1) and 16-bit displacement (disp16) as the operand address.

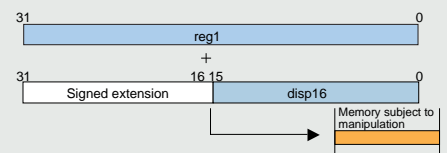

Bit addressing

Addressing that accesses 1 bit of 1 byte of the memory space, with the sum of the contents of the general-purpose register (reg1) and 16-bit displacement (disp16) that has been sign extended to word length as the operand address.

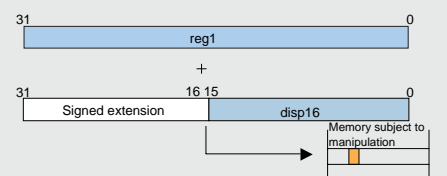

2-byte basic instruction set

The V850 Series employs a 2-byte instruction code to perform basic processing to enable compact program development equivalent to 16-bit CISC microcontrollers.

Improved object efficiency through ROMization programming

Application of 2-byte instructions to all basic processing, consisting of load, store, arithmetic/logic operations, and branching.

To realize ease of use, restrictions on 16-bit fixed-length instructions are partially removed through incorporation of 32-bit instructions.

Bit manipulation instructions, etc.

Object Code Size Comparison (Dhrystone 1.1/Large model)

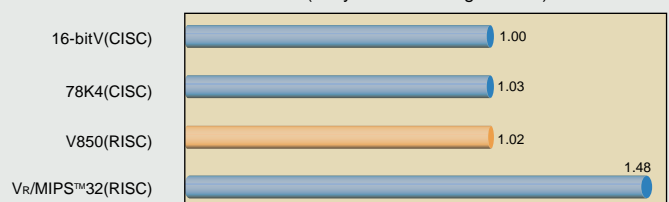

CISC-like instructions for embedding (bit manipulation instructions)

The V850 Series supports bit manipulation instructions suitable for flag manipulation on I/O registers, which play a large role in embedding control.

- Improvement of operability of memory mapped I/Os for control purposes
- Manipulation of any 1 bit of byte data in the memory space
- Provision of test (tst1)/set (set1)/clear (clr1)/invert (not1)
- Effective for reducing object size and execution time since flags can be manipulated in 1-bit units with 1 instruction

Example: Setting (1) bit 6 of ASIM00 register

Item	Bit Manipulation Instruction	When Used	When Not Used
Coding example	set1 6, ASIM00[r0]	ld.b ASIM00[r0], r20 ori 0x0040, r20, r20 st.b r20, ASIM00[r0]	add -4, sp st.w r20, 0[sp] } Save r20 ld.b ASIM00[r0], r20 ori 0x0040, r20, r20 st.b r20, ASIM00[r0] ld.w 0[sp], r20 } Restore r20 add 4, sp
Object size		4 bytes	12 bytes
Execution time		4 clocks	8 clocks

Multi-status flags

In the V850 Series, calculation results are reflected in registers as status flags. As a result, delay branching such as can be seen in the RISC microcontrollers of other manufacturers does not occur and programs can be coded with the same feel as CISC microcontrollers.

- Easy recording with assembler
- Improved object efficiency and execution speed

Example: Program that branches to positive/negative/zero according to register contents

ZERO : Zero processing
PLUS : Positive processing
MINUS : Negative processing

CISC Microcontroller	V850	Other Manufacturer's RISC Microcontroller
cmp ax, 0	cmp 0, r10	cmp/eq #0, r10
jz ZERO	bz ZERO	bt ZERO
jgt PLUS	bgt PLUS	cmp/pl r10
jmp MINUS	br MINUS	bt PLUS
		bra MINUS
		nop ;For delay branching

DSP function

The V850 Series provides a DSP function for executing high-speed calculations and product-sum operations indispensable for digital signal processing such as image and speech processing.

- Direct data handling via general-purpose registers
- Realization of digital signal processing through general-purpose CPU
- High-speed 16-bit (V850, V850ES CPU), 32-bit (V850E1 CPU) multiply/sum-of-products (Multiply: 1 to 2 clocks, sum-of-products: 3 clocks)
- Effective for filter operations and matrix operations for feedback calculations in speed, position, and other servo control.

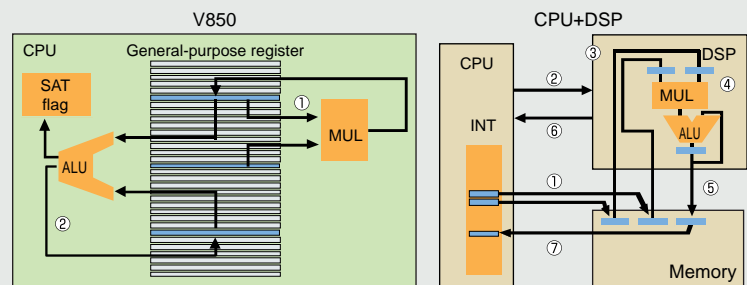

32-bit barrel shifter

V850 Series can realize bit manipulations frequently used during signed data and image data processing in 1 instruction per clock.

- Shifting of any number of bits (0 to 31) executable in 1 instruction per clock
- Improved execution speed/object efficiency
- Effective for extracting arbitrary bit lengths of image data and signed data (extracting code during MH/MR/MMR encoding, etc.)

Example: 27-bit logical right shift

Other manufacturer's RISC microcontroller	Processing sequence	V850
SHR16 Rn	↓	SHR 27, Rn
SHR8 Rn		
SHR2 Rn		
SHR Rn		
4 Number of instructions		1
4 Number of execution clocks		1

V850E1, V850ES Architecture

The V850E1 and V850ES cores achieve high performance and higher code efficiency through the implementation of the following improvements to the V850 CPU core.

Non-blocking load/store

- Improved bus use efficiency
- Shorter interrupt insensitivity period

Addition of branch/load pipes

- 2-clock branching
- Parallel execution of instructions

Shift to 3-operand manipulations in 1 slot

- Improved absolute performance
- Example: Synchronous processing of mov + add

Addition of high-level language-compatible instructions

- Improved code efficiency
- 10 to 15% improvement in object efficiency mainly when C compiler used

Pipeline configuration

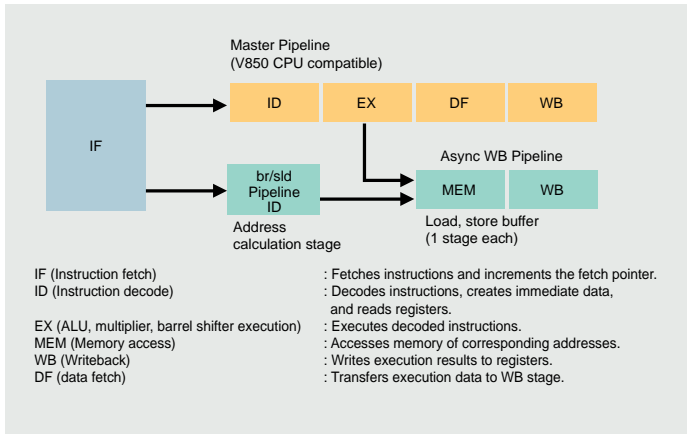

Non-blocking load/store

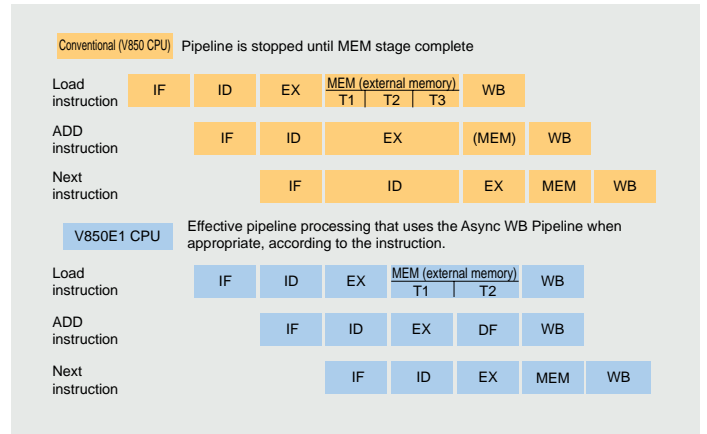

Addition of branch/load pipes

Pipeline operation with branch instruction

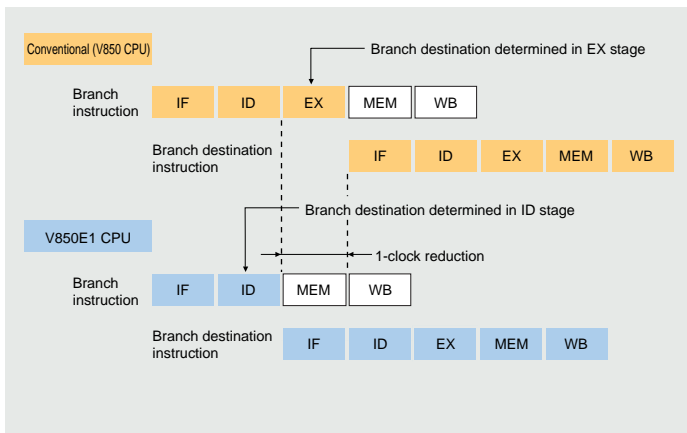

Parallel instruction execution (when executed by internal ROM)

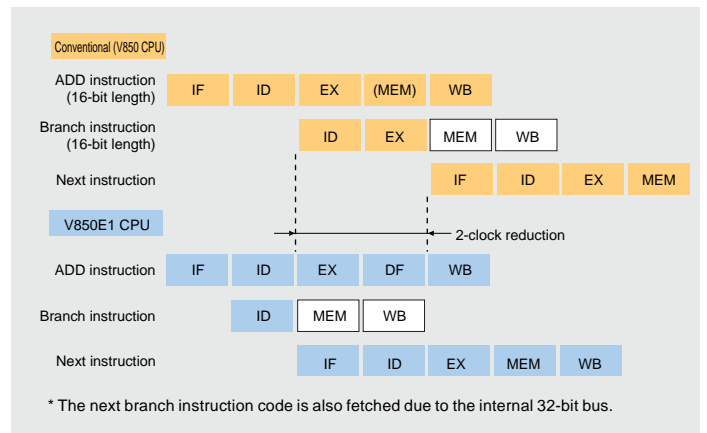

Shift to 3-operand manipulations in 1 slot

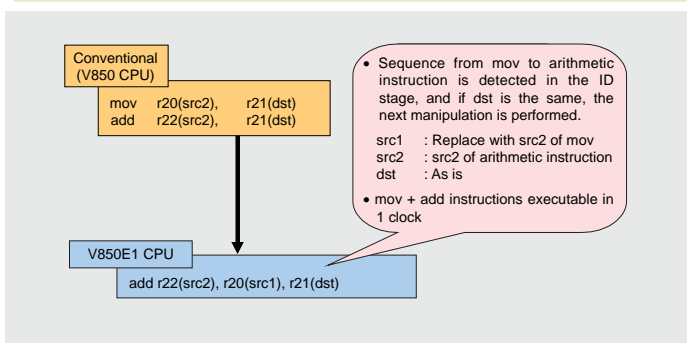

Addition of high-level language compatible instructions

The V850E1 and V850ES cores have enhanced the instruction set of the V850 core as follows.

- ◆ switch (2 bytes)
 - C language switch statement processing converted into instruction
- ◆ callt (2 bytes)/ctret (4 bytes)
 - Table-reference branching
 - Reducing size of call code that frequently appears
- ◆ Data conversion instructions (2 bytes)
 - char, short type cast executed with 1 instruction
 - sxh, sxb, zxb, and zxh instructions
- ◆ prepare/dispose (4 bytes)
 - Function start/end processing executed in 1 instruction
- ◆ unsigned Load
 - Reduction of unsigned manipulation code
- ◆ mov imm32, reg (6 bytes/2 clocks)
 - Reduction of address setting code
- ◆ mul/mulu (4 bytes)
 - Reduction of array address calculation
 - Improvement of sum-of-products performance
- ◆ Other
 - Bit manipulation (register indirect bit specification)
 - cmov (Conditional Move), divide (div/divu/divhu)
 - sasf, endian conversion

V850E2 Architecture

V850E2 core features

- ◆ Real-time performance of 250 MIPS
 - Operation at over 200 MHz
- ◆ Inheritance of V850E1 performance and features
 - Upward instruction compatibility with V850E1 and V850ES cores at object level
 - Use of 7-stage pipeline
 - Parallel pipeline configuration (2 parallel superscalar)
 - 128-bit instruction fetch bus
- ◆ Support of expanding application software sizes
 - Address space (program/data) expansion
 - Strengthened cache memory support

V850E2 core Main added functions

- ◆ 32-bit relative branch instruction
 - Support of program space expansion
 - Long-distance branching performance, elimination of code efficiency losses
- ◆ 3-operand instructions (addition of target operations)
 - Higher speed processing of operations such as multiplex add/subtract (64-bit operation, saturate operation) and bit shift, contributing to higher code efficiency
- ◆ Sum-of-products instruction
 - Higher speed 32-bit sum-of-products operation ($32 \times 32 + 64 \rightarrow 64$ bits)
- ◆ Bit search instruction
 - Bit row change point search for run length measurement, contributing to increased speed of conversion from integers to floating decimals, etc.

V850E2 core CPU pipeline configuration

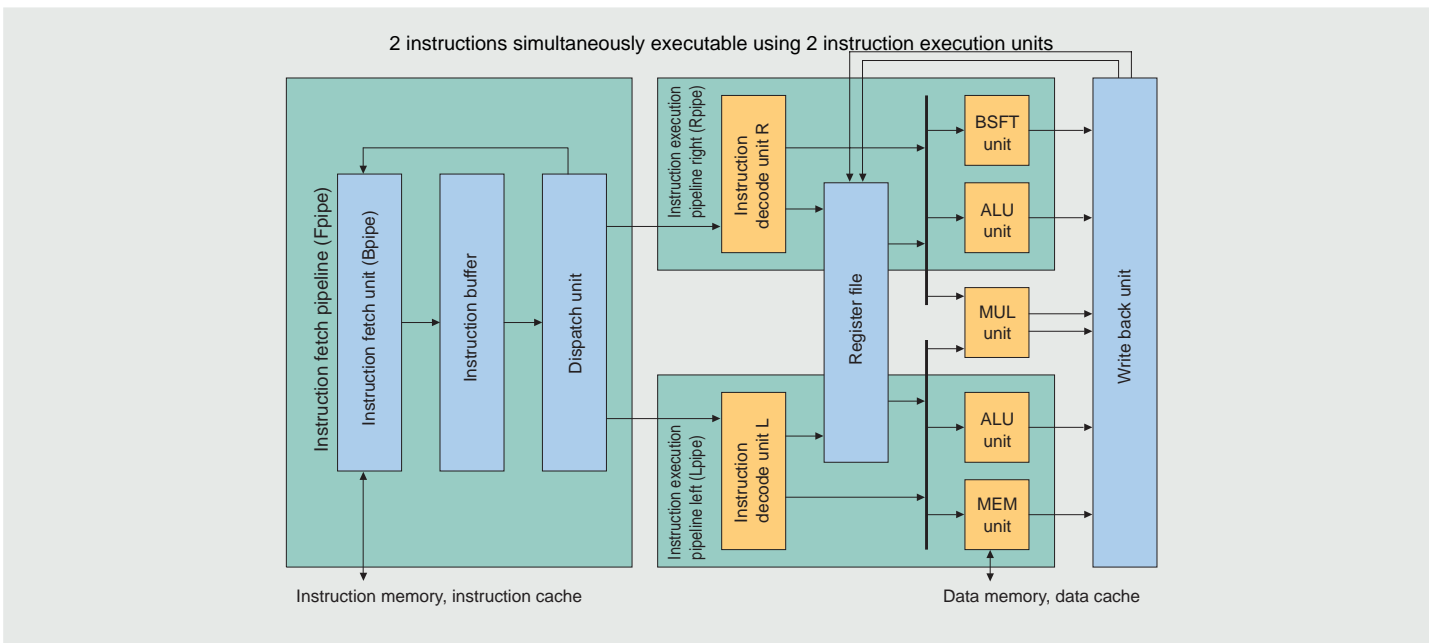

V850E2 core CPU pipeline operation

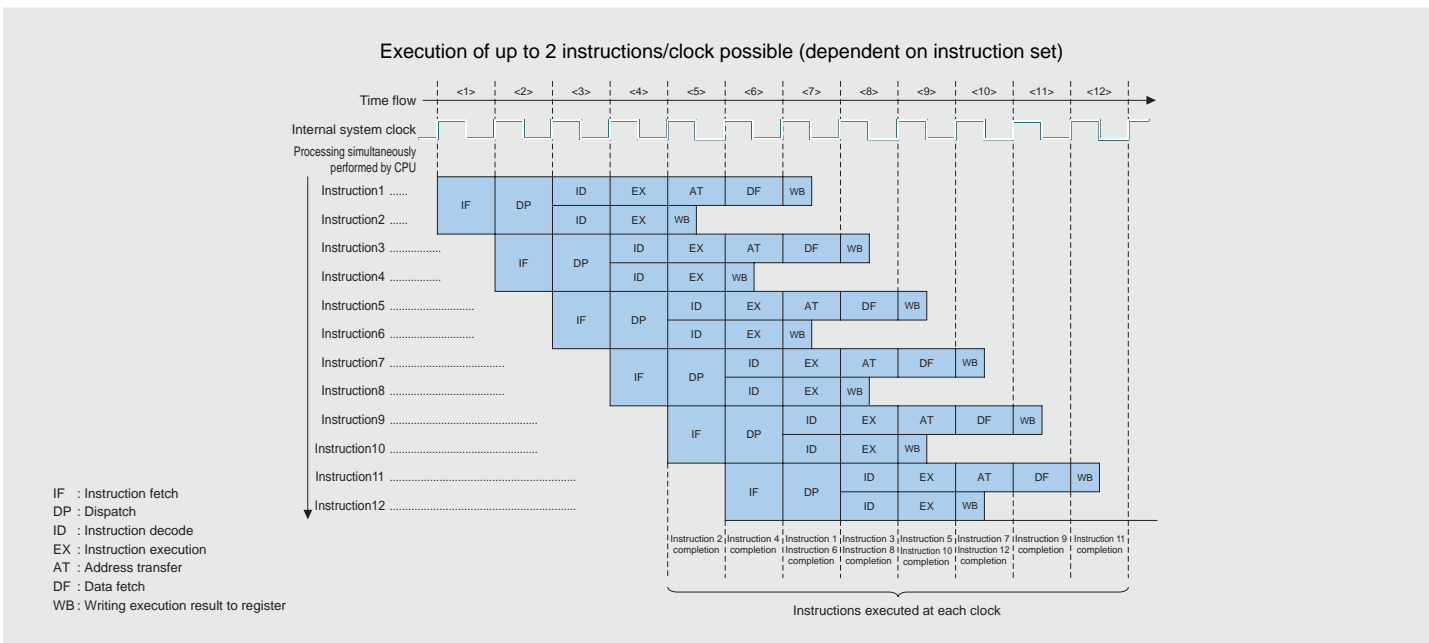

Memory Access Functions

SDRAM controller

Products: V850E/MA1, MA2, MA3, ME2

- ◆ SDRAM connectable without external circuit
- ◆ CAS latency: 2, 3 supported
- ◆ CBR (automatic) refresh: Self refresh supported

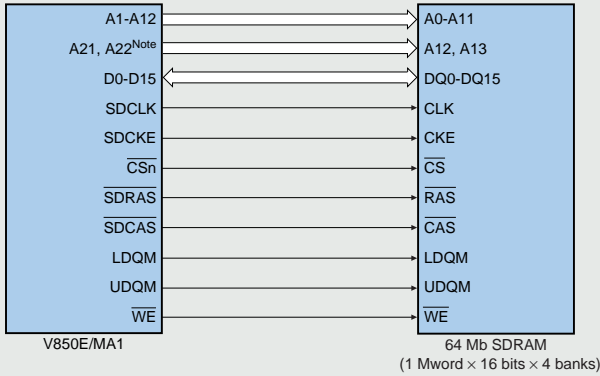

Note The address signal used differs depending on the SDRAM product.

DMA controller (provided in V850E products)

Products: V850E/MA1, MA2, MA3, MS1, MS2, IA1, IA2, IA3, IA4, ME2, SV2

- ◆ Transfer targets: Memory-peripheral I/O, memory-memory
- ◆ Transfer mode: Single, single step, block transfer
- ◆ Transfer units: 8/16 bits
- ◆ Transfer type: 1-cycle transfer, 2-cycle transfer
- ◆ Number of transfers: 65536 Max.

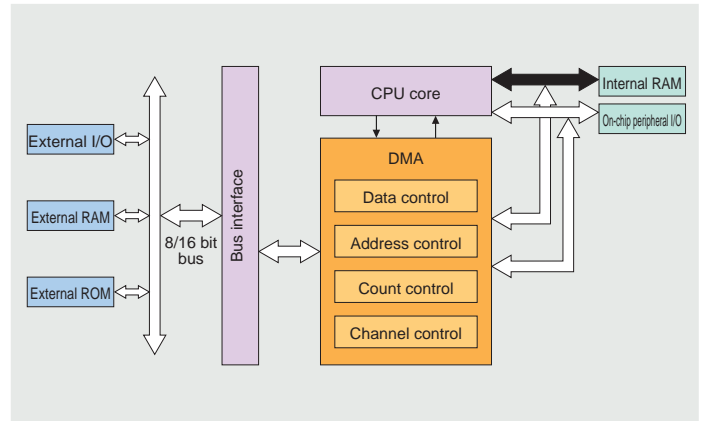

DMA controller (provided in V850ES products)

Products: V850ES/SA2, SA3, SG2, SJ2, KG1+, KJ1+, FG2, FJ2
μPD703229Y, 70F3229Y

- ◆ Transfer targets: Memory-peripheral I/O, memory-memory
- ◆ Transfer mode: Single
- ◆ Transfer units: 8/16 bits
- ◆ Transfer type: 2-cycle transfer
- ◆ Number of transfers: 65536 Max.

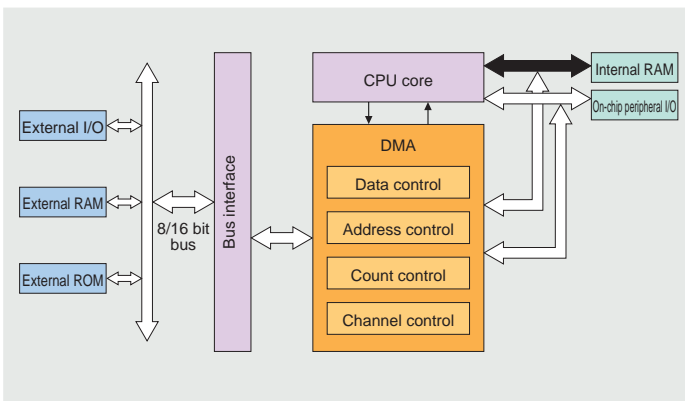

DMA controller (provided in V850/Sxx products)

Products: V850/SA1, SB1, SB2, SV1, SF1, SC1, SC2, SC3

- ◆ Transfer targets: Internal RAM-on-chip peripheral I/O
- ◆ Transfer mode: Single
- ◆ Transfer units: 8/16 bits
- ◆ Transfer clock: 4 clocks Min.
- ◆ Number of transfers: 256 Max.

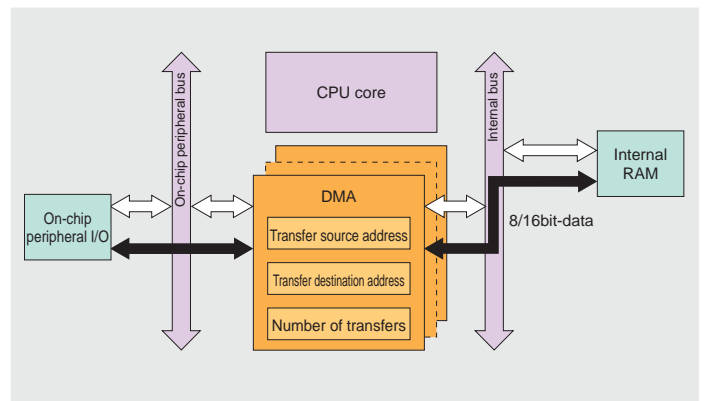

Analog Circuits

● $\Delta\Sigma$ A/D converter

Products: V850ES/PM1

- ◆ High-accuracy 16-bit resolution
- ◆ Sampling frequency selector (4.340 kHz/2.170 kHz)
- ◆ Support of up to 3 lines and 4 phases through multiple input channels

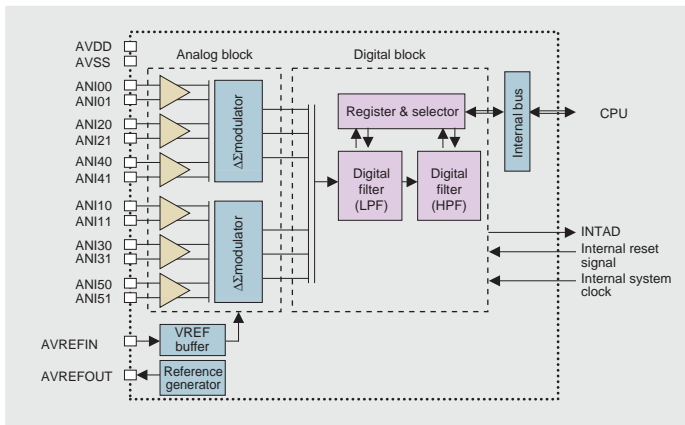

● High-speed A/D converter

Products: V850E/IA3, IA4

- ◆ Simultaneous 10-bit A/D converter sampling for 2 circuits
- ◆ On-chip operational amplifier (2.5 ×/5 ×) for input level amplification
- ◆ On-chip overvoltage detection comparator

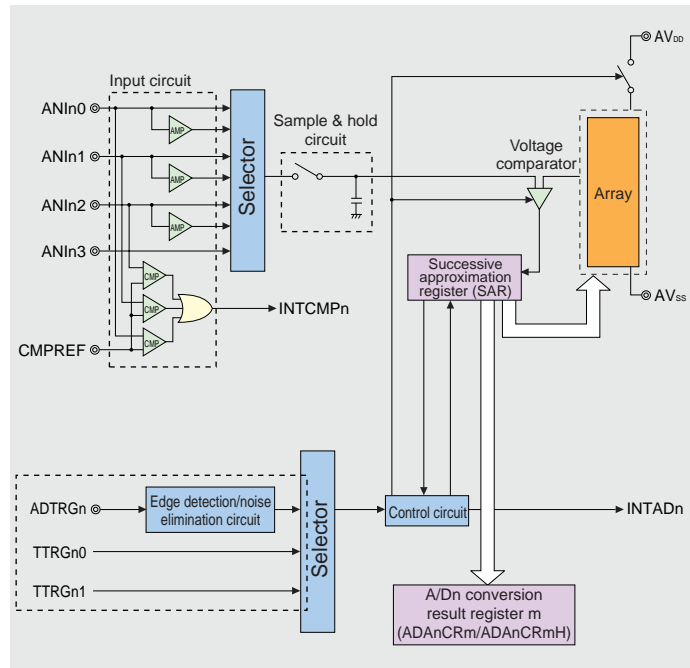

● A/D converter (multi-stage buffer type)

Products: V850E/MA1, MA3, ME2, IA1, IA2, MS1, SV2, V850/SV1, V853, etc.

- ◆ Conversion startable by software or hardware
- ◆ 8 on-chip conversion result registers (24 for SV2)
- ◆ Select/scan mode switching possible

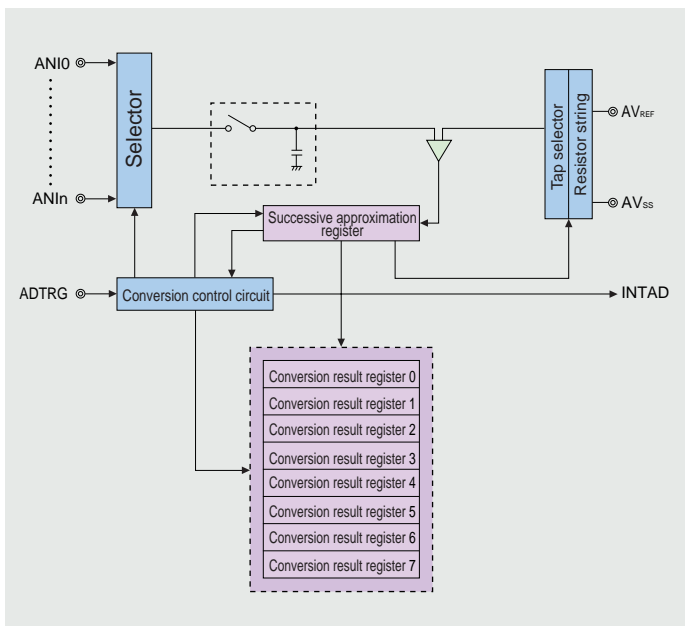

● D/A converter

Products: V850ES/KG1, KJ1, KG1+, KJ1+, SA2, SA3, SG2, SJ2, V850E/MA3, V853

- ◆ R-2R ladder method (except for V850ES/SA2, SA3)
- ◆ R string method (V850ES/SA2, SA3 only)
- ◆ 8-bit resolution
- ◆ Operation mode: Normal mode/real-time output mode

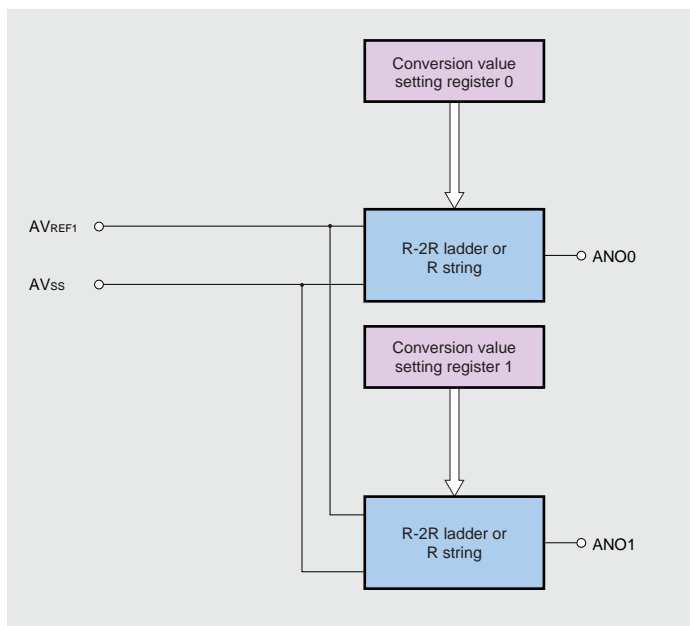

Timer/Counter

Timer configuration during inverter control

- Products: V850E/IA3, IA4, MA3, V850ES/IK1
- ◆ 0% and 100% output and 6-phase PWM output with deadtime possible
 - ◆ Switchable anytime/batch overwrite for compare register
 - ◆ A/D converter conversion start trigger generator

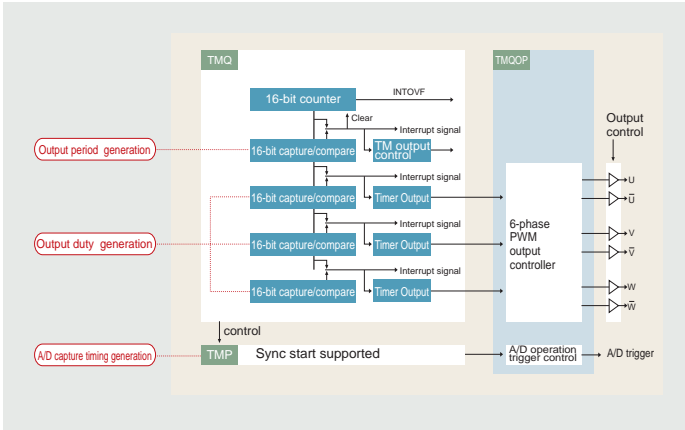

Up/down counter

- Products: V850E/IA1, IA2, IA3, IA4, MA3, ME2
- ◆ 16-bit 2-phase encoder input possible
 - ◆ Compare registers: 2
 - ◆ Capture/compare registers: 2

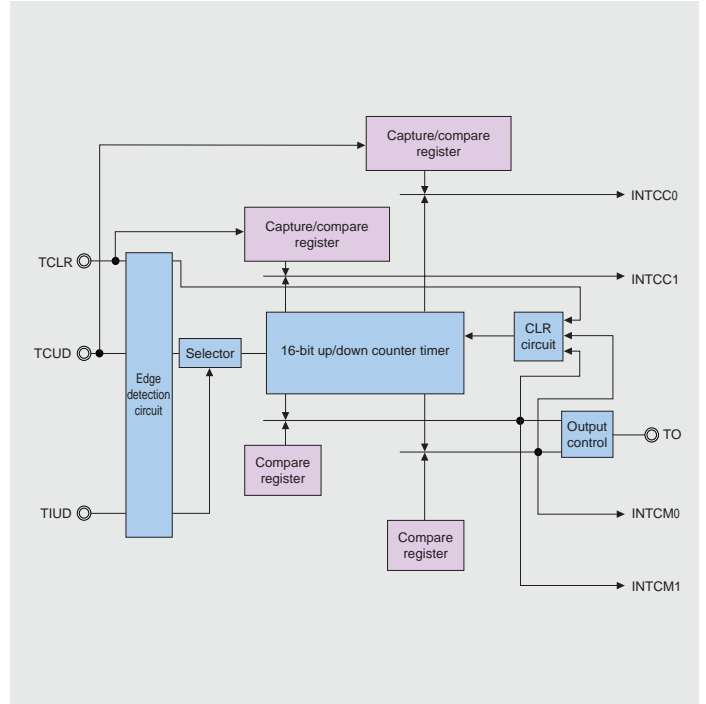

32-bit servo timer

- Products: V850E/SV2
- ◆ 32-bit timer unit for servo control
 - ◆ Capture registers: 12
 - ◆ Compare registers: 2
 - ◆ External input detection circuit with 1 to 256 dividers
 - ◆ On-chip 8-bit mask timers: 2

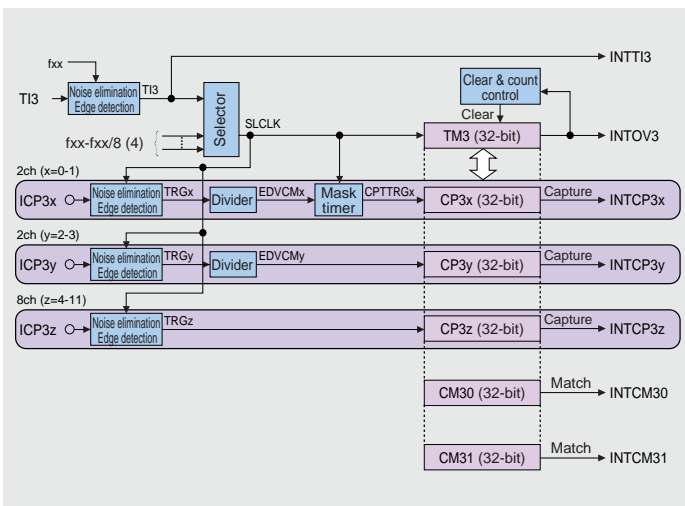

Real-time counter

- Products: V850ES/SA2, SA3, PM1
- ◆ On-chip week, day, hour, minute, second counters
 - ◆ Counting up to 4095 periods
 - ◆ Support of interval interrupt generation at fixed intervals selectable from: 0.015625 s, 0.03125 s, 0.0625 s, 0.125 s, 0.25 s, 0.5 s, 1 s, 1 mn, 1 hr, 1 day

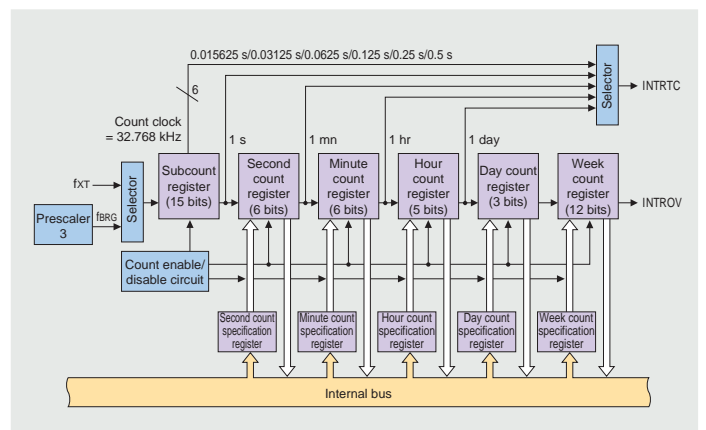

Serial Interface

Serial interface with automatic send/receive function

Products: V850E/SV2, V850ES/KF1, KG1, KJ1, KF1+, KG1+, KJ1+

- ◆ 32-byte internal buffer RAM
- ◆ Automatic send/receive function
 - 1 to 32 bytes of transfer bytes specifiable
 - Transfer interval specifiable (0 to 63 clocks)
 - Single transfer/repeated transfer specifiable

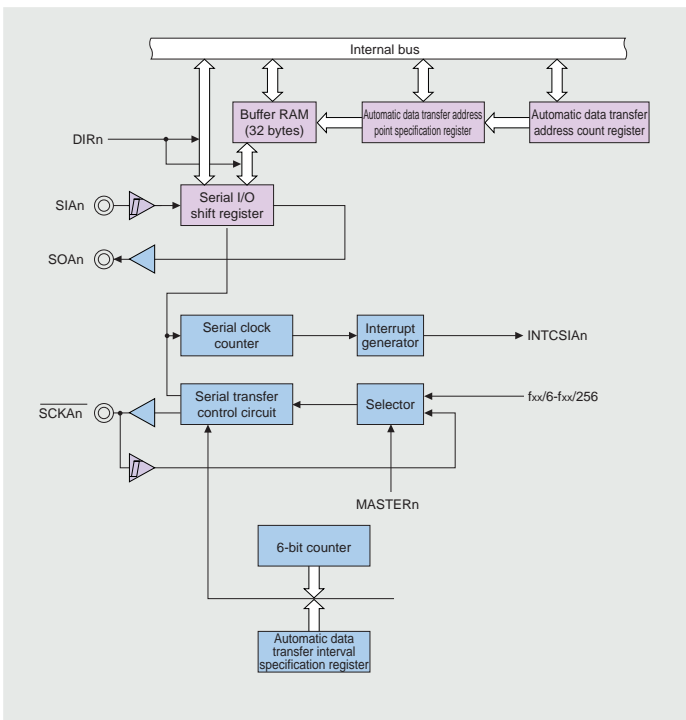

LINBus

Products: V850ES/KE1+, KF1+, KG1+, KJ1+, SG2, SJ2, μ PD703229Y, 70F3229Y, V850ES/FE2, FF2, FG2, FJ2

- ◆ Low-cost 1-line network bus
- ◆ Sync break field (SBF) send/receive possible through hardware
(Send: $13 \text{ bits} \leq \text{SBF} \leq 20 \text{ bits}$; Receive: $\text{SBF} \geq 11 \text{ bits}$)
- ◆ Also generally usable as UART

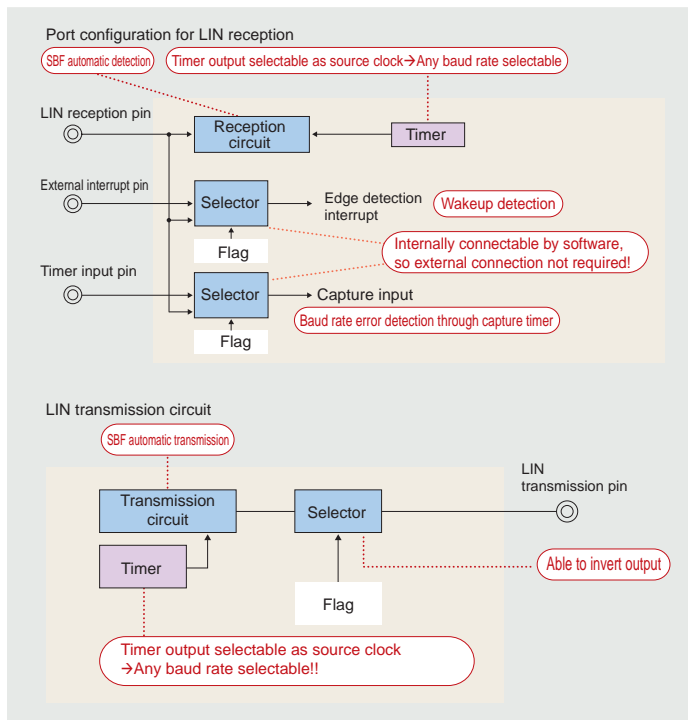

CAN

Products: V850ES/SG2, SJ2, FE2, FF2, FG2, FJ2, V850E/IA1, V850/SF1, SC3, DB1

- ◆ CAN protocol ver. 2.0 Part B (send/receive of standard and extended frames)
- ◆ Max. transfer rate: 500 kbps (V850/DB1 only) 1 Mbps
- ◆ 32 message buffer

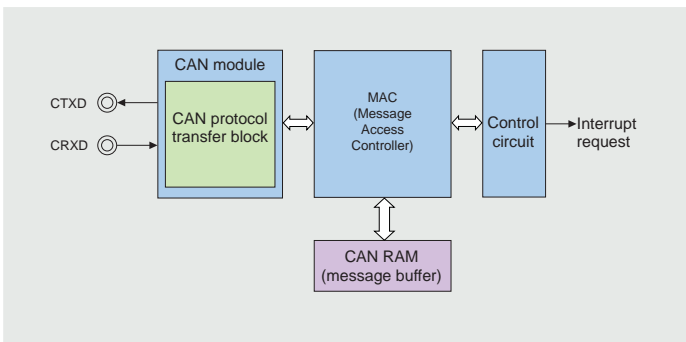

IEBus controller

Products: V850ES/SG2, SJ2, V850/SB2, SC2

- ◆ Communication mode 1 supported
- ◆ Max. transfer bytes: 32 bytes/frame
- ◆ Max. transfer speed: Approx. 17 kbps

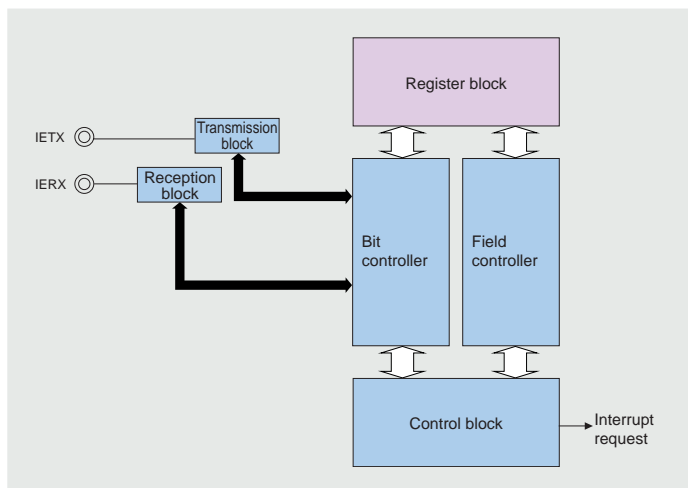

Other

USB

Products: V850E/ME2

- ◆ Compliant with Universal Serial Bus Specification
- ◆ Support of 12 Mbps (full speed) transfer
- ◆ Many endpoint configurations

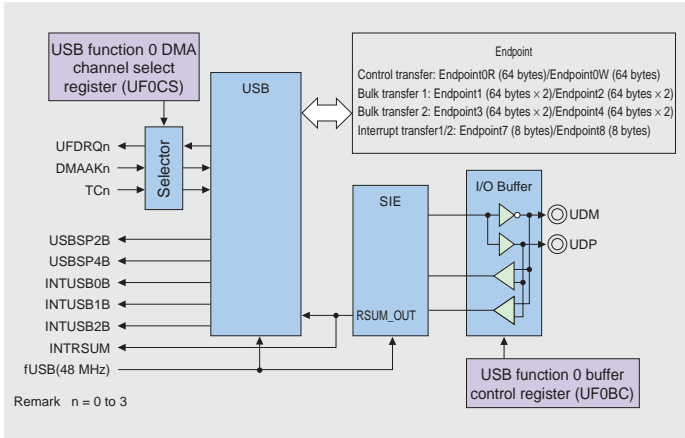

SSCG function (Spread spectrum Frequency Synthesizer Clock Generator)

Products: V850E/ME2

- ◆ EMI peak noise reduction through input frequency modulation
- ◆ Large reduction in noise countermeasure time and cost possible
- ◆ Frequency modulation rate and modulation period changeable by register setting

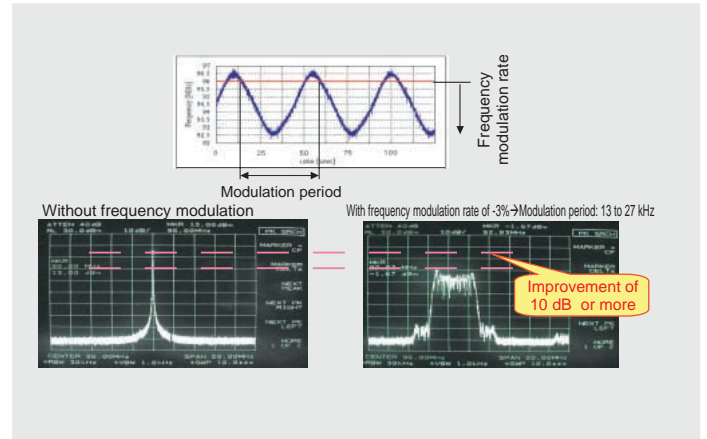

ROM correction function

Products: V850 core :V850/SB1, SB2, SV1, SF1, SC1, SC2, SC3
 V850E, V850ES cores :V850ES/SA2, SA3, SG2, SJ2, KE1, KF1, KG1, KJ1, KE1+, KF1+, KG1+, PM1, IK1, μ PD703229Y, 70F3229Y, V850E/MA3, SV2, IA3, IA4

- ◆ Instructions of address to be modified inserted to replace DBTRAP instruction (JMP r0 instruction in case of V850 core), branching to 0060H (0000H in case of V850 core)
- ◆ Program modification following switch to mask ROM possible
- ◆ Modified addresses: 4 points, 8 points^{Note}

Note V850E/SV2

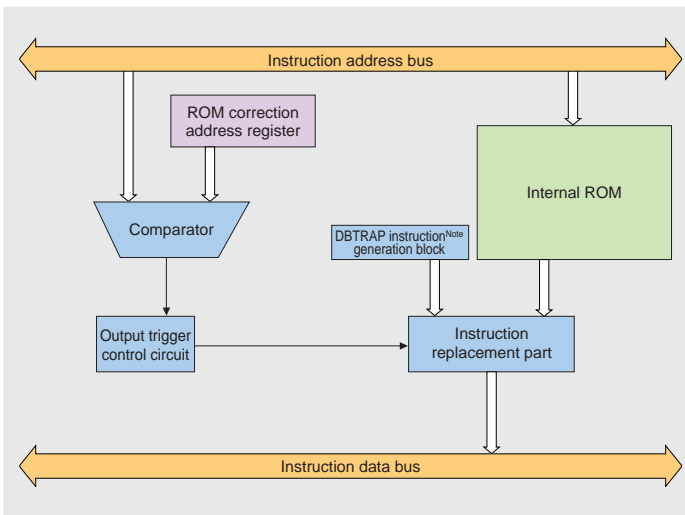

Note JMP r0 instruction for the V850 core

Explanation of ROM correction operation

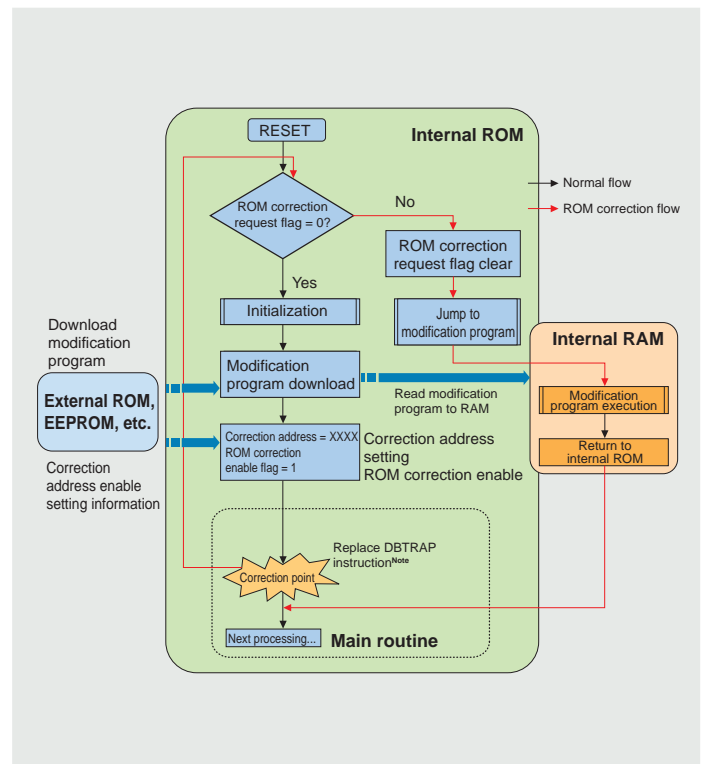

Note JMP r0 instruction in case of V850 core

Low-voltage detection circuit (LVI)

Products: V850ES/KE1+, KF1+, KG1+, KJ1+, SG2, SJ2, μ PD703229Y, 70F3229Y, V850ES/FE2, FF2, FG2, FJ2, IK1

- ◆ Detection voltage level changeable by software
- ◆ Usable instead of reset IC, contributing to lower system cost
- ◆ Detection voltage not changeable after mode transition (security protection)

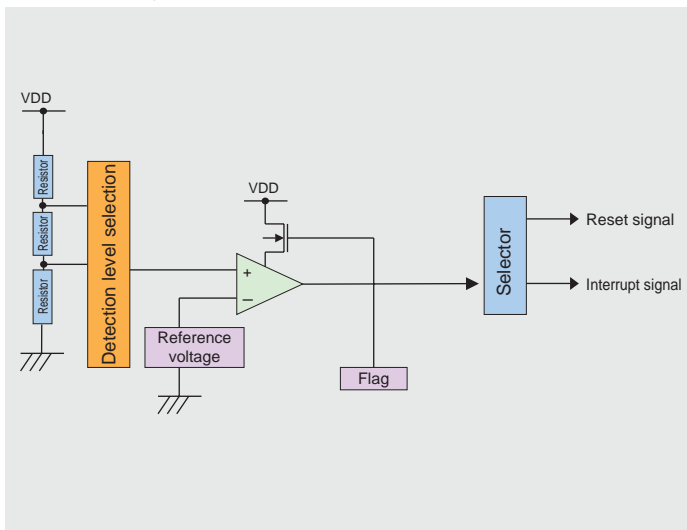

Clock monitor function

Products: V850ES/KE1+, KF1+, KG1+, KJ1+, SG2, SJ2, μ PD703229Y, 70F3229Y, V850ES/FE2, FF2, FG2, FJ2, IK1

- ◆ Monitors abnormal stops of main clock with internal Ring-Oscillator
- ◆ During abnormal stop, entire system can be set to reset status
- ◆ Prevention of destruction due to system deadlock or runaway

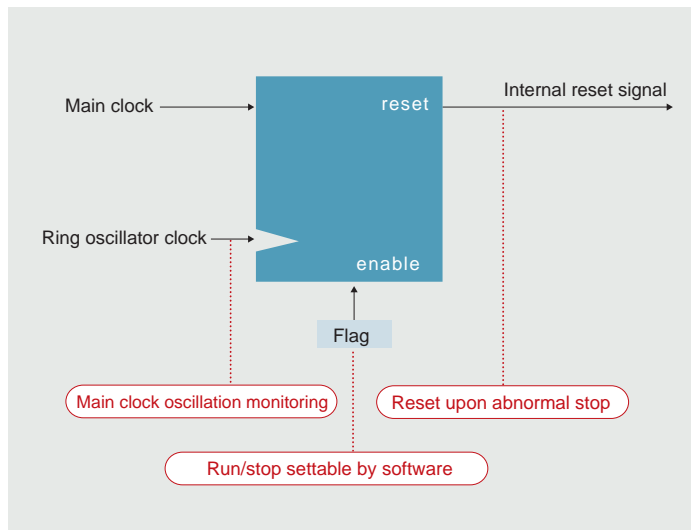

On-chip debugging function

Products: V850E/ME2^{Note}, V850E/MA3, IA4, SV2, V850ES/KJ1, KJ1+, SG2, SJ2, FE2, FF2, FG2, FJ2, μ PD70F3229Y

- ◆ Realization of on-chip debugging of microcontroller with DCU (Debug Control Unit)
- ◆ Compact and low-cost PC card-type emulator
- ◆ Flash programmer function
- ◆ Integrated debugger (ID850) supported

Note Trace function support is possible by using the RTE-2000-TP made by Midas Lab Co., Ltd., or PARTNER-ET II, PARTNER-J made by Kyoto Micro Computer Co., Ltd.

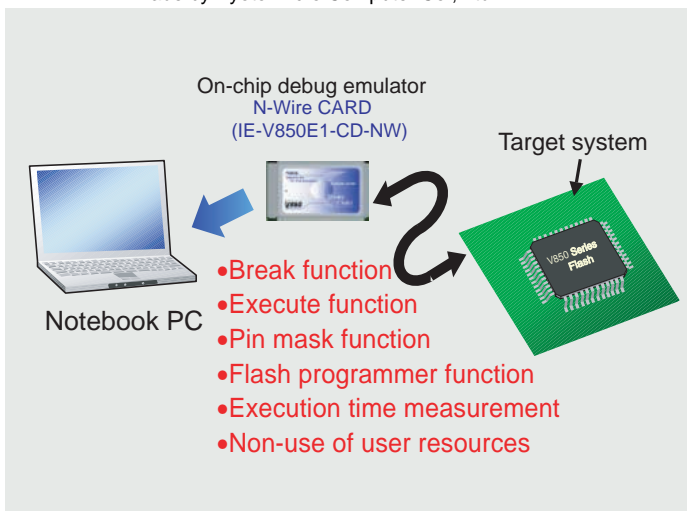

Boundary scan function

Products: V850E/SV2

- ◆ Use of JTAG (Joint Test Action Group) communication specifications, IEEE1149.1 compliant
- ◆ Progressive scan of device's external I/O pins, test data input/output possible
- ◆ Connection check of devices soldered on user board possible

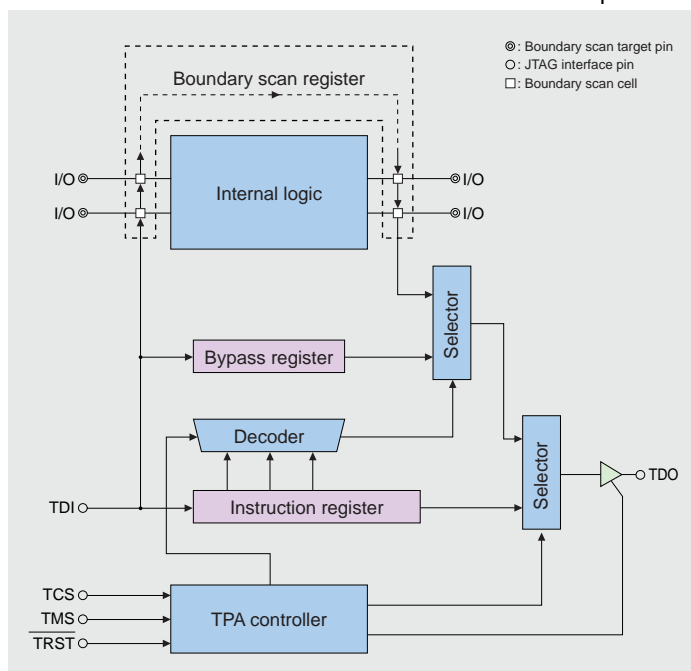

Performance

V850 Series Benchmark

The V850 Series realizes high speed, high performance, and high code efficiency.

Minimum instruction execution time

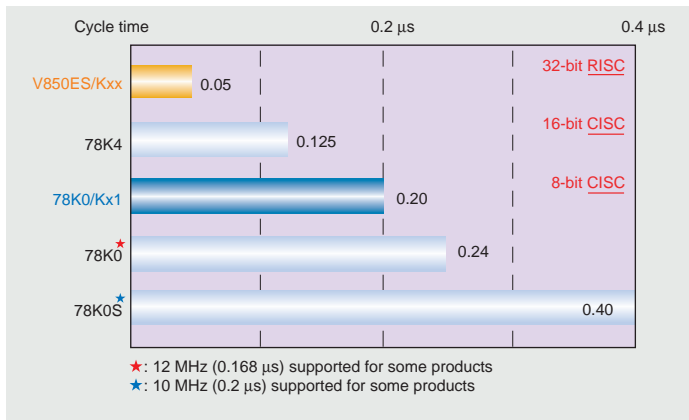

V850 Series performance

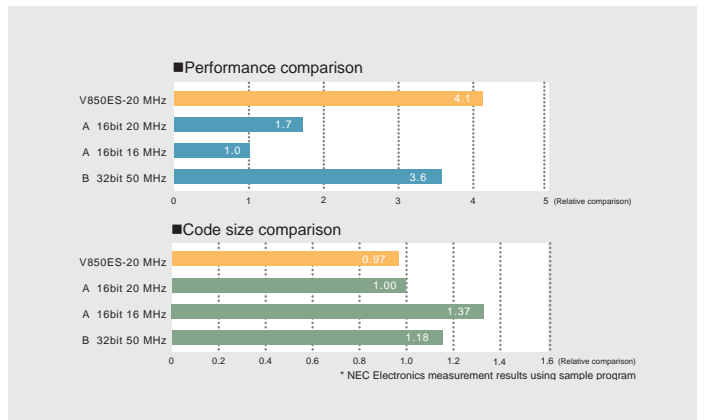

Low Power Consumption

Thanks to thorough energy-saving design, a superior current/performance ratio of 1.1 to 0.7 mA/MIPS is realized, particularly for V850ES and V850/Sxx products. As a result, a reduction in power consumption to 1/5 or less compared to 16-bit CISC microcontrollers of similar performance is realized. Lower system power consumption and higher performance are simultaneously realized through this extremely high power performance.

Power performance

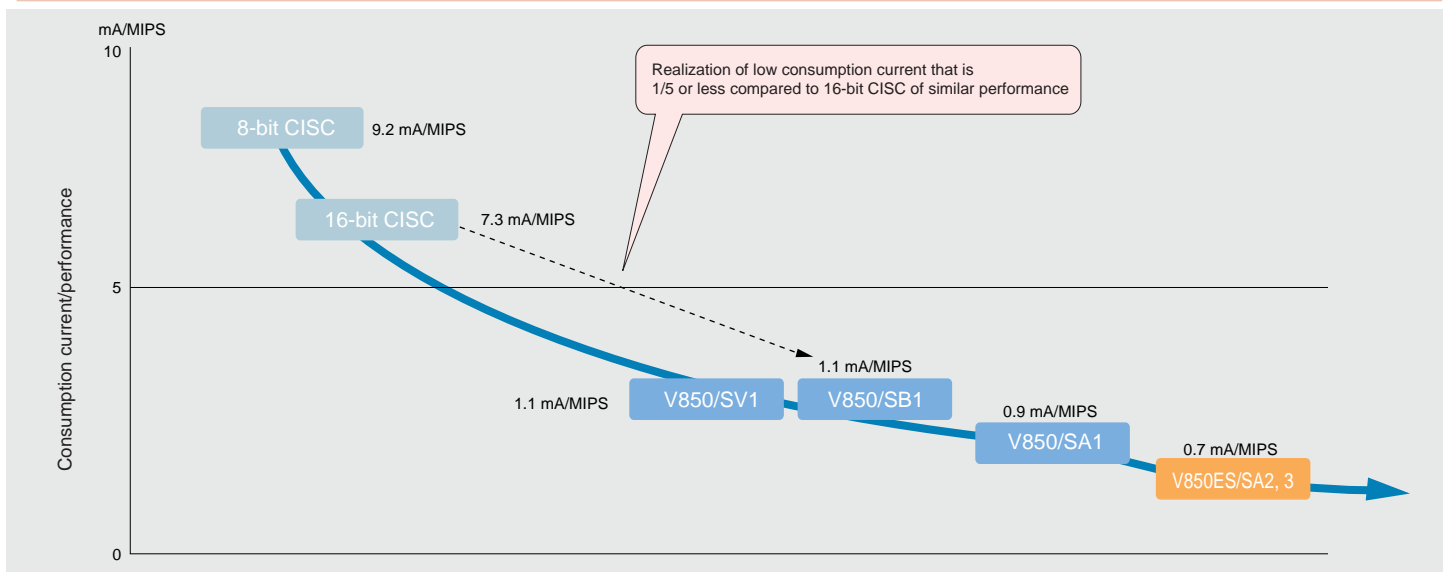

Clock gear function

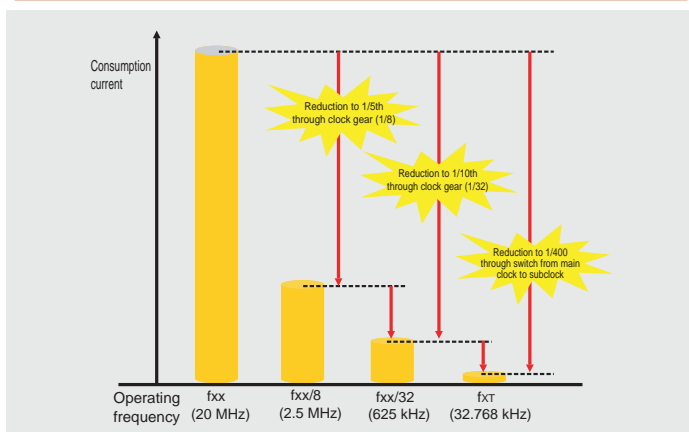

Standby mode

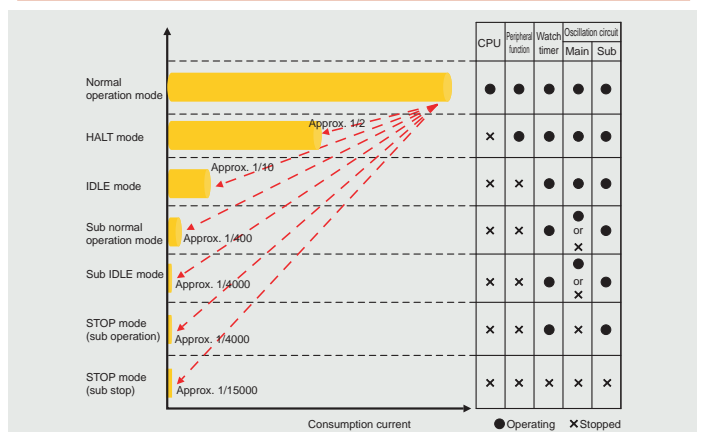

Low Noise Countermeasures

Minimizing the influence of electromagnetic interference (EMI) emitted from the microcontroller and the influence of noise applied to the microcontroller (EMS) is a high priority, particularly for AV equipment such as car audio systems, and thus superior noise performance is required of microcontrollers. Various noise countermeasures are implemented in the V850 Series, and noise performance equivalent or superior to that of 16-bit products has been realized.

EMS countermeasures

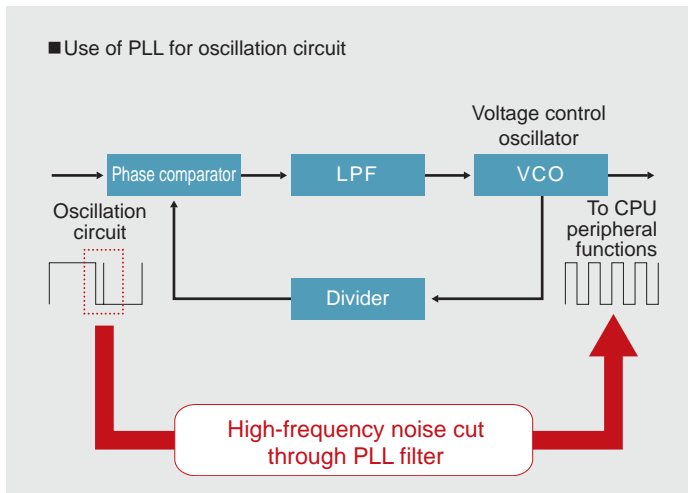

EMS measurement results (power supply coupling measurement)

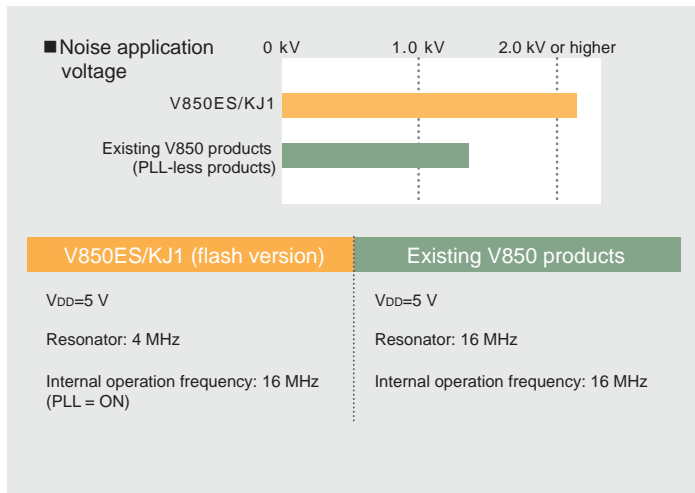

EMI noise countermeasures: Power supply circuit countermeasures

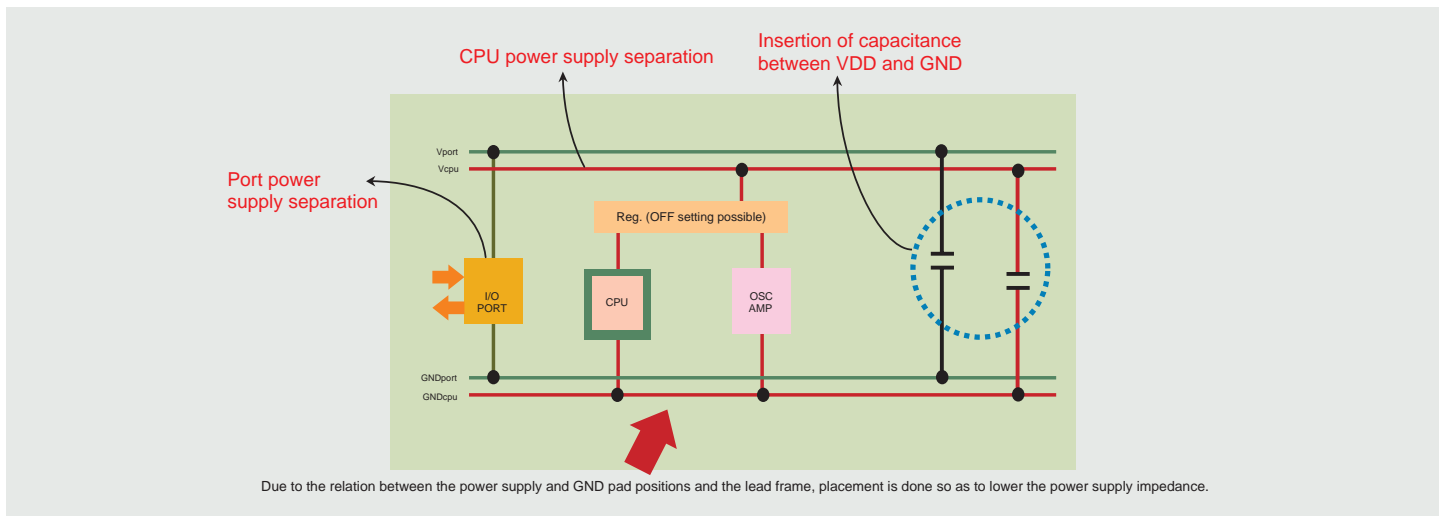

EMS noise measurement results

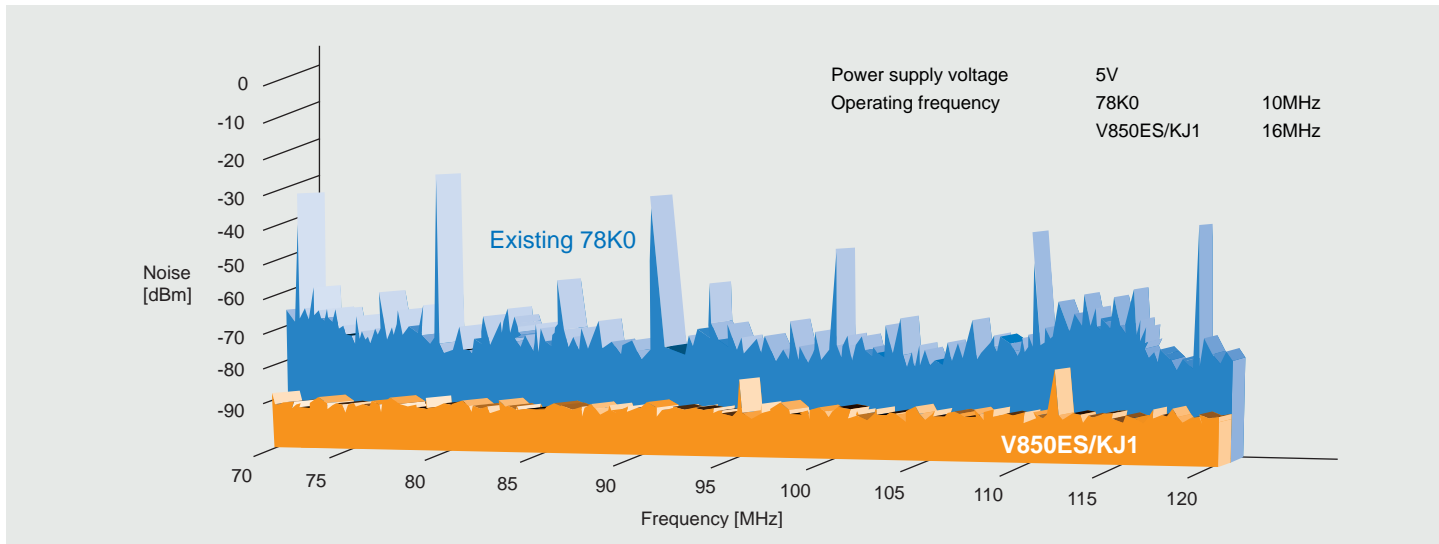

V850 Series Middleware List

Middleware plays a major role for maximizing processor performance and realizing high-speed processing of complex data with flexibility and ease.

NEC Electronics offers a large array of middleware that is optimized for the CPU architecture and importantly contributes to shortening development time, while also facilitating additions and changes to dedicated functions whose implementation as hardware for devices, etc., used to have high cost and time requirements, and the creation of user-friendly interfaces.

Middleware merits:

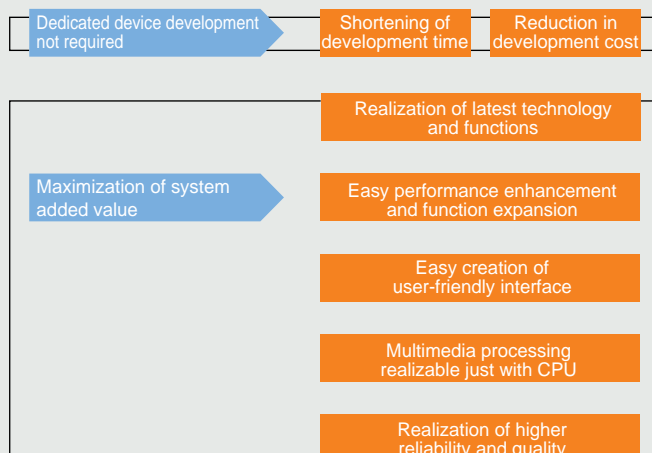

Shift to middleware accelerating deployment to optimum processors

An increasing number of processors optimized for various systems and based on NEC Electronics' original technology and the superb technology of third parties, as well as other technologies that have been established as standards, are being deployed from.

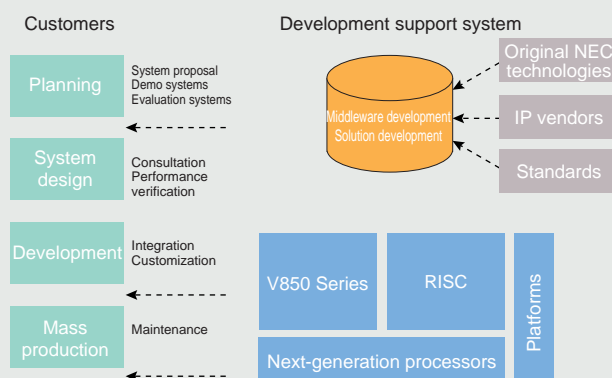

Middleware product list

Category	Middleware	V850 Series	
Image	JPEG	◎	
	MPEG-4/H.263 Video	—	
Speech	Text To Speech	◎	
	Speech CODEC	Japanese	◎
		G.723.1 Annex A/C	—
		G.726 (ADPCM)	◎
		G.729 Annex A/B	—
		AMR	—
	MPEG-4 CELP	—	
	Acoustic echo canceller (for hands-free operation)	AEC	—
Noise suppressor	3GPP-NS	—	
Sound	Audio decoder	AAC	—
		MP3	—
		WMA	—
	Sound generator for cellular phone ringer melody		—

Category	Middleware	V850 Series	
Recognition	Speech recognition	Japanese (large vocabulary)	—
		Japanese (small vocabulary)	◎
		Chinese (small vocabulary)	◎
	Handwriting recognition	English (small vocabulary)	◎
		Japanese (input frame required)	◎
	Japanese (input frame not required)	—	
Security	Encryption	CIPERUNICORN	◎
	Fingerprint recognition		◎
Internet	TCP/IP	◎	
Storage	PC-compatible file system	◎	

◎ : Development completed

Middleware performance list

Middleware	Performance	Power (MIPS)	ROM	RAM
JPEG	QVGA×24 : Enc0.32s/Dec0.24s	—	17.5 KB	15 KB
G.726 (ADPCM)	32Kbps, 16Kbps	Enc8/Dec8.2	9 KB	80 B
Speech recognition (small vocabulary)	0.4s	19 (20 words)	82 KB	3.5 KB (15 words)
		63 (100 words)		

Speech Recognition

Speech recognition is realized on a single chip using the memory and peripheral I/Os in the V850 Series. Ideal for applications such as games and home appliances that must feature speech recognition but are subject to large restrictions.

- Realization of speech recognition with memory and peripheral I/Os contained in V850 Series
- Expansion of number of recognized words
Recognized number of words: 30 words (in case of V850/SA1, 20 MHz)

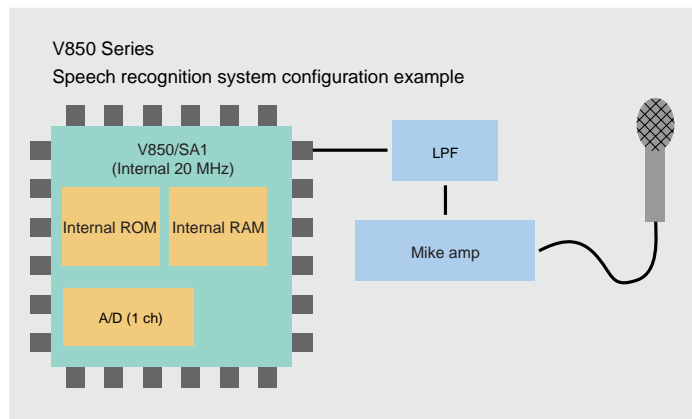

- Realization of speech recognition using only memory and peripheral I/Os contained in V850 Series
- Expansion of number of recognized words

Expansion of number of recognized words

Main dictionary	Sub dictionary 1
Friend	Jim, Marc, Sally
Company	Sub dictionary 2
Reservation	Smith, Jones, Brown
.	Sub dictionary 3
.	ANA, JAL, ticket

Memory capacity

ROM/RAM	Description	Capacity
ROM	Program	26 KB
	Data	40 KB
ROM/RAM mix	Recognition dictionary (in case of 15 words)	0.5 KB
RAM	Work area (in case of 15 words)	3.4 KB
	Stack	0.3 KB

Recognition dictionary and work vary depending on the number of recognized words.

Speech recognition evaluation system

NEC Electronics provides an environment allowing easy evaluation for the introduction of speech recognition. For details and the purchasing method, consult your NEC Electronics sales representative.

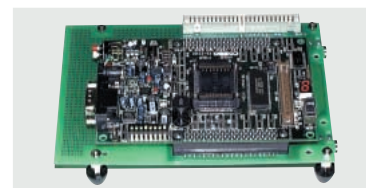

JPEG

- Conforms to JPEG international standard
Conforms to DCT baseline process (non-reverse coding)
- Versatile compression and decompression processing
 - <Compression functions>
 - User-customizable VRAM input module
 - User-specified Huffman and quantization tables
 - APPn marker insertion
 - Compression suspend function
 - <Decompression processing>
 - User-customizable VRAM output module
 - Support of various JPEG markers (DRI, RSTn, DNL)
 - Decompression suspend function

JPEG performance

CPU	Sample Ratio	Processing Time			
		QVGA (320×240×24)		VGA (640×480×24)	
		Compression	Decompression	Compression	Decompression
V850E/MS1 (33MHz) ^{Note}	4:1:1 (Quality75)	0.32 s	0.24 s	1.3 s	0.97 s

Note Programs are placed in internal ROM, and stack and (some) work areas are placed in internal RAM. The data and other works are placed in external RAM.

Memory

ROM		RAM	
Compression	Decompression	Compression	Decompression
10 KB	7.5 KB	5 KB	10 KB

Text to Speech (for Japanese Text)

- Speech synthesized from Japanese Kana and Kanji text (SJIS code)
- Versatile speech synthesis
Synthesis of female voices possible
Various adjustable parameters such as intonation and reading speed
- Rhythm of synthesized speech (pitch, phoneme duration) can be designed (Speech Designer compatible)
Speech synthesis using natural rhythm possible (synthesis of more natural sounding speech)
- Support of special characters (Reading of special characters settable in user dictionaries)
- Synthesis speed
Works also with V850/SA1 (20 MHz). (However, text is placed in internal ROM.)

ROM/RAM	Description	Capacity
ROM	Program	126 KB
	Data	35 KB
	Dictionary data (approx. 80,000 words)	1.2 MB
	Phoneme data	567 KB (8 kHz sampling) 684 KB (11 kHz sampling)
RAM	Work	160 KB
	Stack	508 bytes
	Speech output buffer	12 KB

Features

To answer the need for shorter development time and maintenance after shipping, NEC Electronics offers microcontrollers with on-chip flash memory available in a large range of capacities from 64 KB to 640 KB as part of the V850 Series. NEC Electronics' flash memory microcontrollers offer the following features.

- ◆ Flash capacity
64 to 640 KB
- ◆ Overwrite unit
Entire memory at one time, or block units
- ◆ Rewrite method
Serial communication with dedicated flash memory programmer (on-board, off-board)
Self-flash programming
- ◆ Rewrite voltage
Single-power-supply flash: Operation voltage
Dual-power-supply flash: Operation voltage
7.8 V/10.3 V
- ◆ Rewrite count:
100 times

Flash microcontroller lineup

Flash Memory Size (bytes)	64K		128K				192K				256K				384K				512K				640K
	4K	4K	6K	8K	12K	16K	8K	10K	12K	16K	16K	24K	32K	20K	24K	32K	48K						
V850ES/KE1		○																					
V850ES/KF1		○	○/○						○														
V850ES/KG1		○	○/○							○													
V850ES/KJ1		○	○/○							○													
V850ES/KE1+*		○																					
V850ES/KF1+*			○						○														
V850ES/KG1+*			○							○													
V850ES/KJ1+*			○							○													
V850ES/SG2													○							○			
V850ES/SJ2													○							○			
μPD70F3229Y													○										
V850ES/SA2,SA3												○											
V850/SA1		○						○															
V850/SB1										○			○				○						
V850/SB2											○		○				○						
V850/SC1,SC2,SC3																	○						
V850E/MA3																			○				
V850E/MA1										○													
V850E/MS1		○																					
V853		○						○															
V850E/IA3, IA4										○													
V850E/IA2			○																				
V850E/IA1										○													
V850ES/IK1*			○																				
V850ES/FE2*		○																					
V850ES/FF2*			○									○											
V850ES/FG2*			○									○		○									
V850ES/FJ2*												○		○		○							
V850E/SV2													○		○				○				
V850/SV1													○		○								
V850/SF1													○		○								
V850/DB1			○																				

○: Single power supply
 ○: Dual power supply
 ○/○: Single power supply/dual power supply
 *: Under development

Rewrite Modes

To enable integrated use ranging from development to mass production and maintenance, the V850 Series supports a programmer rewrite mode that uses serial communication supporting on-board programming, as well as a self-programming mode that rewrites flash memory with user programs.

- ◆ On-board programming mode
This programming mode is used to rewrite the flash memory mounted on the target system using a dedicated flash memory programmer.
- ◆ Off-board programming mode
This programming mode is used to rewrite flash memory using a dedicated flash memory programmer and dedicated program adapter (FA Series^{Note 1}).
- ◆ Self-programming mode
This programming mode is used to rewrite flash memory by executing the user program written beforehand to the flash memory using on-board/off-board programming.^{Note 2}

Notes 1. The FA Series is a product of Naito Densai Machida Mfg. Co., Ltd.
 2. Since instruction fetch and data access cannot be performed from the internal flash memory area during self-programming, a program for rewriting internal RAM or external memory must be transferred in advance.

Programmer program (on-board/off-board)

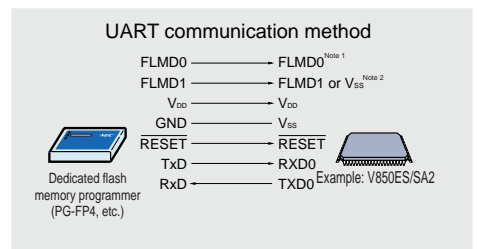
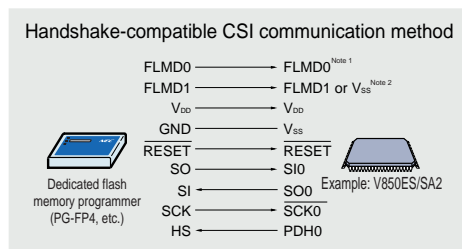
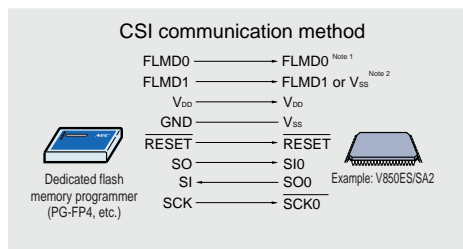

Note 1. In the case of dual-power-supply flash, V_{PP}

Note 2. In the case of dual-power-supply flash, don't connect.

Self-programming mode (single-power-supply method)

Flash memory can be erased and rewritten using a self-programming library from a program placed in an area outside the flash memory.

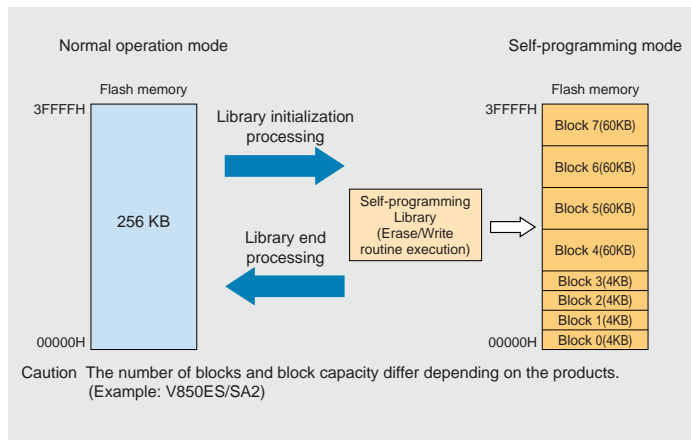

Self-programming flow

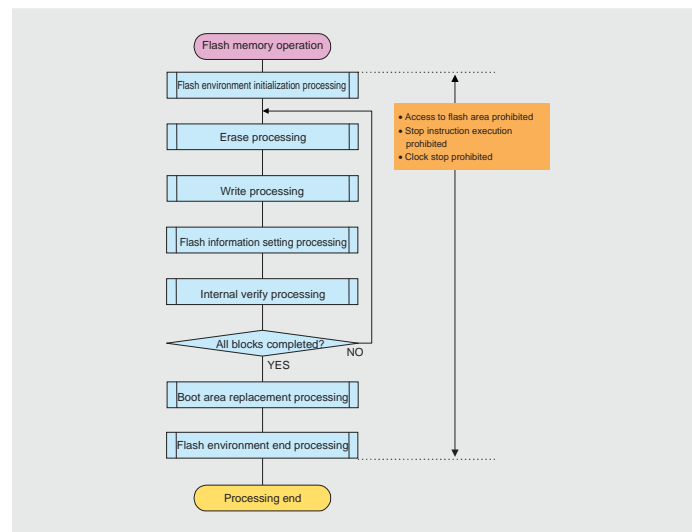

Flash Specifications List

Category	Part No.	Flash Memory Capacity	Max. Operating Frequency	Rewrite Voltage		Rewrite Mode			Rewrite Count (Times)
				V _{DD}	V _{PP}	On-Board/Off-Board Programming		Self-Programming	
						CSI	UART		
Low end	V850ES/KE1	128 KB	20 MHz	4.5 V to 5.5 V	—	√	√	√	100
	V850ES/KF1	256 KB/128 KB	20 MHz	4.5 V to 5.5 V	—	√	√	√	100
	V850ES/KF1	128 KB	20 MHz	4.5 V to 5.5 V	10.3 V	√	√	—	100
	V850ES/KG1	256 KB/128 KB	20 MHz	4.5 V to 5.5 V	—	√	√	√	100
	V850ES/KG1	128 KB	20 MHz	4.5 V to 5.5 V	10.3 V	√	√	—	100
	V850ES/KJ1	256 KB/128 KB	20 MHz	4.5 V to 5.5 V	—	√	√	√	100
	V850ES/KJ1	128 KB	20 MHz	4.5 V to 5.5 V	10.3 V	√	√	—	100
	V850ES/KE1+*	128 KB	20 MHz	4.5 V to 5.5 V	—	√	√	√	100
	V850ES/KF1+*	256 KB/128 KB	20 MHz	4.5 V to 5.5 V	—	√	√	√	100
	V850ES/KG1+*	256 KB/128 KB	20 MHz	4.5 V to 5.5 V	—	√	√	√	100
Middle range	V850ES/SG2	640 KB/384 KB	20 MHz	2.85 V to 3.6 V	—	√	√	√	100
	V850ES/SJ2	640 KB/384 KB	20 MHz	2.85 V to 3.6 V	—	√	√	√	100
	μPD70F3229Y	384 KB	20 MHz	3.5 V to 5.5 V	—	√	√	√	100
	V850ES/SA2	256 KB	20 MHz	2.2 V to 2.7 V	—	√	√	√	100
	V850ES/SA3	256 KB	20 MHz	2.2 V to 2.7 V	—	√	√	√	100
	V850/SA1	256 KB/128 KB	20 MHz	3.0 V to 3.6 V	7.8 V	√	√	√	100
	V850/SB1	512 KB/384 KB/256 KB	20 MHz	4.0 V to 5.5 V	7.8 V	√	√	√	100
	V850/SC1	512 KB	20 MHz	3.5 V to 5.5 V	7.8 V	√	√	√	100
High end	V850E/MA3	512 KB	80 MHz	2.3 V to 2.7 V (internal) 3.0 V to 3.6 V (external)	—	√	√	√	100
	V850E/MA1	256 KB	50 MHz	3.0 V to 3.6 V	7.8 V	√	√	√	100
	V850E/MS1	128 KB	33 MHz	3.0 V to 3.6 V	7.8 V	√	√	—	100
	V850E/MS1	128 KB	33 MHz	3.0 V to 3.6 V (internal) 4.5 V to 5.5 V (external)	7.8 V	√	√	√	100
	V853	256 KB/128 KB	33 MHz	4.5 V to 5.5 V	10.3 V	√	√	—	20
ASSP	V850E/IA4	256 KB	64 MHz	2.3 V to 2.7 V (internal) 4.5 V to 5.5 V (external)	—	√	√	√	100
	V850E/IA3	256 KB	64 MHz	2.3 V to 2.7 V (internal) 4.5 V to 5.5 V (external)	—	√	√	√	100
	V850E/IA2	128 KB	40 MHz	4.5 V to 5.5 V	7.8 V	√	√	√	100
	V850E/IA1	256 KB	50 MHz	3.0 V to 3.6 V (internal) 4.5 V to 5.5 V (external)	7.8 V	√	√	√	100
	V850ES/IK1*	128 KB	32 MHz	4.5 V to 5.5 V	—	√	√	√	100
	V850E/SV2	512 KB	40.5 MHz	2.3 V to 2.7 V (internal) 2.7 V to 3.6 V (external)	—	√	√	√	100
	V850ES/FE2*	128 KB/64 KB	20 MHz	4.0 V to 5.5 V	—	√	√	√	100
	V850ES/FF2*	256 KB/128 KB	20 MHz	4.0 V to 5.5 V	—	√	√	√	100
	V850ES/FG2*	384 KB/256 KB/128 KB	20 MHz	4.0 V to 5.5 V	—	√	√	√	100
	V850ES/FJ2*	512 KB/384 KB/256 KB	20 MHz	4.0 V to 5.5 V	—	√	√	√	100
	V850/SV1	384 KB/256 KB	20 MHz	3.1 V to 3.6 V	7.8 V	√	√	√	100
	V850/SB2	512 KB/384 KB/256 KB	19 MHz	4.0 V to 5.5 V	7.8 V	√	√	√	100
	V850/SC2	512 KB	20 MHz	3.5 V to 5.5 V	7.8 V	√	√	√	100
	V850/SC3	512 KB	20 MHz	3.5 V to 5.5 V	7.8 V	√	√	√	100
	V850/SF1	256 KB	16 MHz	3.5 V to 5.5 V	7.8 V	√	√	√	100
V850/DB1	128 KB	16 MHz	4.0 V to 5.5 V	7.8 V	√	√	√	100	

*: Under development

Flash Memory Programmers

● NEC Electronics flash memory programmer: PG-FP4

[Features]

- ◆ Supports write to all NEC Electronics microcontrollers with internal flash memory.
- ◆ USB support through host machine interface
- ◆ Allows verification of various types of information, including programmer setting information, error messages, and check-sum, even in stand-alone configuration, from the main unit's LCD.
- ◆ Enables downloading of two types of user code and selecting of valid code
- ◆ Device-specific information required for writing automatically settable with parameter files
- ◆ Supports both on-board programming and program adapter programming.
- ◆ Easy-to-carry A5 size
- ◆ Simple operation either on stand-alone basis and on Windows™ 95/Windows 98/Windows Me/Windows 2000/Windows XP, Windows NT™ 4.0 using a dedicated application (Flashpro4)



● Flash memory programmer configuration

PG-FP4 allows single-microcontroller programming when used with a program adapter (FA Series of Naito Densai Machida Mfg. Co., Ltd.). On-board programming can also be performed.

A sample rewrite environment when using the program adapter is shown below.

Rewrite environment example

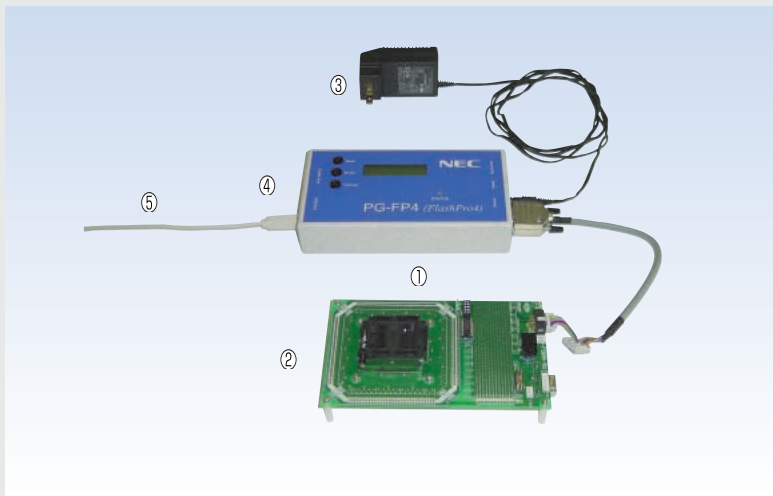

- ① Flash memory program (PG-FP4)
- ② Target system
- ③ Power-supply unit
- ④ Host machine interface (USB)
- ⑤ To host machine

- Cautions**
1. Install the PG-FP4 control software and target device parameter file in the host machine.
 - PG-FP4 control software: Bundled with PG-FP4
 - PG-FP4 parameter file: Distributed via online delivery service
 2. In addition to programming using the program adapter, on-board programming on the target system is also possible.

● Third-party flash memory programmers (1/2)

● Programming system Y1000-8

[Manufacturer/Distributor] Wave Technology Co., Ltd.

[Target Devices] V850/SV1, SB1 (μPD70F3032B, 70F3033B), SB2 (70F3035B, 70F3037H), V850E/IA1 (70F3116), MA1

[Features]

- ◆Gang programmer enabling simultaneous programming and verification of up to 8 devices
- ◆ Enables reading of master data directly from floppy disk to internal memory
- ◆Data dump display and editing functions
- ◆Master data storable on internal hard disk
- ◆Designed for simple and comfortable operation via touch panel, and superior operability via PASS/FAIL display, check-sum display, and task count display supporting sockets.

[Additional information]

TEL : +81-3-5304-1885 FAX : +81-3-5304-1886

E-mail : sales@y1000.com

Website: http://www.y1000.com/index_e.html



● Third-party flash memory programmers (2/2)

● FlashPRO IV: FL-PR4

[Manufacturer/Distributor] Naito Densai Machida Mfg. Co.

[Target Devices] V850 Series

[Features]

- ◆ Supports writing to all NEC Electronics microcontrollers with internal flash memory.
- ◆ USB support through host machine interface
- ◆ Allows verification of various types of information, including programmer setting information, error messages, and check-sum, even in stand-alone configuration, from the main unit's LCD.
- ◆ Enables downloading of two types of user code and selecting of valid code
- ◆ Device-specific information required for writing automatically settable with parameter files
- ◆ Supports both on-board programming and program adapter programming.
- ◆ Easy-to-carry A5 size
- ◆ Simple operation either on stand-alone basis and on Windows 95/Windows 98/Windows Me/Windows 2000/Windows XP, Windows NT 4.0 using a dedicated application (Flashpro4)

[Additional information]

TEL : +81-45-475-4191 FAX : +81-45-475-4091

E-mail : info@ndk-m.co.jp

Website: <http://www.ndk-m.co.jp/asmis/eng/index.html>



● NET IMPRESS

[Manufacturer/Distributor] Yokogawa Digital Computer Corporation

[Target Devices] V850/SB1 (μPD70F3033B), SB2(70F3037H), SA1(70F3017A), SC3(70F3089Y), V853(70F3003A, 70F3025A), V850E/MS1(70F3102A), MA1(70F3107), IA1, IA2(70F3114), V850ES/KF1(70F3210), FE2, FF2, FG2, FJ2, SG2, SJ2

[Features]

- ◆ Enables programming of flash memory microcontrollers of various writing specifications solder mounted on user system boards.
- ◆ One control module is the key to this product's versatility.
Microcontrollers of the same family are supported by changing parameters, and microcontrollers of different families are supported by purchasing the required license for the descriptor part.
- ◆ Can be used on standalone basis as well as via a host machine.
- ◆ Rich lineup of downloadable freeware

[Additional Information]

TEL : Japan +81-42-333-6224

U.S.A +408-941-0132 (Yokogawa Corporation of America)

Europe +44-1256-811998 (Ashling Microsystems Limited)

Korea +82-2-785-3929 (KM DATA INC.)

South East Asia +65-6563-2082 (Unidux Electronics Pte Ltd.)

FAX : Japan +81-42-352-6109

U.S.A +408-941-0121 (Yokogawa Corporation of America)

Europe +44-1256-811761 (Ashling Microsystems Limited)

Korea +82-2-785-3117 (KM DATA INC.)

South East Asia +65-6569-4661 (Unidux Electronics Pte Ltd.)

Website: http://www.ydc.co.jp/micom/index_E.htm



● Flash Burner Forward FL-S01, Flash Gang Forward FL-G01

[Manufacturer] Forward Electric Co., Ltd. (Hong Kong)

[Distributor] Application Co., Ltd.

[Target Devices] V850/SB1(70F3033A), V850E/MA1

[Features]

- ◆ Host machine interface supports USB.
- ◆ Easy operation and rich array of GUI software provided
- ◆ Low cost from development to mass production
- ◆ Compact and easy to carry (FL-S01)
- ◆ Gang programmer enabling simultaneous programming of up to 8 devices (FL-G01)
- ◆ Can be used on standalone basis using compact flash (FL-G01).
- ◆ Programming adapter board (option) usable in common for FL-S01 and FL-G01.

[Additional Details]

TEL : +81-42-732-1377 FAX : +81-42-732-1378

Website: http://www.apply.co.jp/index_eng.html

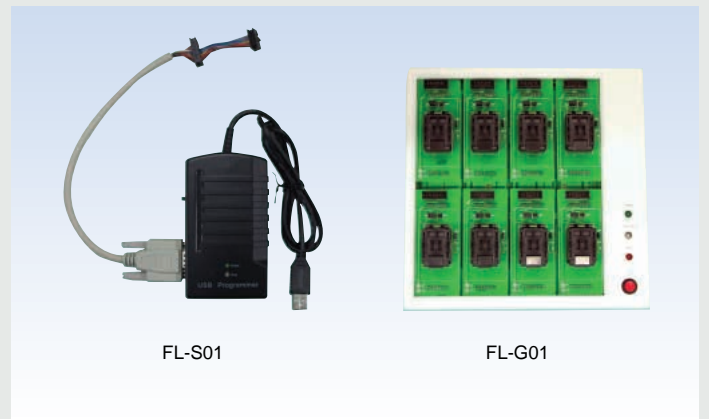

FL-S01

FL-G01

Product Specifications List

Low-End Lineup (1/2)

Item	V850ES/KE1			V850ES/KF1		
	Part No.	μPD703207/3207Y	μPD70F3207H/F3207HY	μPD703208/3208Y	μPD703209/3209Y	μPD703210/3210Y μPD70F3210H/F3210HY
CPU core	V850ES			V850ES		
CPU performance	29 MIPS (@20 MHz: 5 MHz × 4)			29 MIPS (@20 MHz: 5 MHz × 4)		
Internal ROM	128 KB (mask)	128 KB (flash)	64 KB (mask)	96 KB (mask)	128 KB (mask)	256 KB (mask)
Internal RAM	4 KB		4 KB		128 KB (flash)	256 KB (flash)
External bus interface	Bus type	Multiplexed				
	Address bus	16 bits				
	Data bus	8/16 bits				
	Chip select signal	2				
Memory controller	SDRAM, etc.					
Interrupt sources	Internal	25 (Y products: 26)		25 (Y products: 26)		28 (Y products: 29)
	External	8 (8) ^{Note 1}		8 (8) ^{Note 1}		8 (8) ^{Note 1}
Timer/counter	16-bit timer/event counter (TM0) × 1 ch 16-bit timer/event counter (TMP) × 1 ch 8-bit timer/event counter (TMH) × 2 ch 8-bit timer/event counter (TM5) × 2 ch 8-bit interval timer (BRG) × 1 ch			16-bit timer/event counter (TM0) × 2 ch 16-bit timer/event counter (TMP) × 1 ch ^{Note 3} 8-bit timer/event counter (TMH) × 2 ch 8-bit timer/event counter (TM5) × 2 ch 8-bit interval timer (BRG) × 1 ch		
Watchdog timer	2 ch			2 ch		
Serial interface	CSI × 2 ch UART × 2 ch I ² C × 1 ch ^{Note 2}			CSI with automatic transfer function (32-byte buffer) × 1 ch CSI × 2 ch UART × 2 ch I ² C × 1 ch ^{Note 2}		
A/D converter	10-bit × 8 ch			10 bits × 8 ch		
D/A converter	-			-		
DMA controller	-			-		
Ports	I/O	43		59		
	Input	8		8		
Debug control unit	-			-		
Other peripheral functions	Watch timer: 1 ch, ROM correction function: 4 points, real-time output			Watch timer: 1 ch, ROM correction function: 4 points, real-time output		
Operating frequency	When using main clock: 2 to 20 MHz When using subclock: 32.768 kHz			When using main clock: 2 to 20 MHz When using subclock: 32.768 kHz		
Power supply voltage	2.7 to 5.5 V			2.7 to 5.5 V		
Power consumption (Typ.)	200 mW (128 KB mask products: 20 MHz @ 5 V operation) 39.6 mW (128 KB mask products: 10 MHz @ 3.3 V operation)			150 mW (128 KB mask products: 20 MHz @ 5 V operation) 29.7 mW (128 KB mask products: 10 MHz @ 3.3 V operation)		
Package	64-pin TQFP (12 × 12 mm) 64-pin LQFP (10 × 10 mm)			80-pin TQFP (12 × 12 mm) 80-pin QFP (14 × 14 mm)		
Operating ambient temperature	-40 to +85°C			-40 to +85°C		

Notes 1. Number of external interrupts that can be used to release STOP mode
 2. Only Y products have an on-chip I²C interface.
 3. μPD703211, 703211Y, 70F3211H, 70F3211HY only

Item	V850ES/KG1				V850ES/KJ1		
	Part No.	μPD703212/3212Y	μPD703213/3213Y	μPD703214/3214Y μPD70F3214H/F3214HY	μPD703215/3215Y μPD70F3215H/F3215HY	μPD703216/3216Y	μPD703217/3217Y μPD70F3217H/F3217HY
CPU core	V850ES				V850ES		
CPU performance	29 MIPS (@ 20 MHz: 5 MHz × 4)				29 MIPS (@ 20 MHz: 5 MHz × 4)		
Internal ROM	64 KB (mask)	96 KB (mask)	128 KB (mask)	256 KB (mask)	96 KB (mask)	128 KB (mask)	256 KB (flash)
Internal RAM	4 KB		6 KB	16 KB	6 KB		16 KB
External bus interface	Bus type	Multiplexed/separate					
	Address bus	22 bits					
	Data bus	8/16 bits					
	Chip select signal	2					
Memory controller	SRAM, etc.						
Interrupt sources	Internal	30 (Y products : 31)		33 (Y products : 34)	38 (Y products : 40)		41 (Y products : 43)
	External	8 (8) ^{Note 1}			8 (8) ^{Note 1}		
Timer/counter	16-bit timer/event counter (TM0) × 4 ch 16-bit timer/event counter (TMP) × 1 ch ^{Note 2} 8-bit timer/event counter (TMH) × 2 ch 8-bit timer/event counter (TM5) × 2 ch 8-bit interval timer (BRG) × 1 ch				16-bit timer/event counter (TM0) × 6 ch 16-bit timer/event counter (TMP) × 1 ch ^{Note 3} 8-bit timer/event counter (TMH) × 2 ch 8-bit timer/event counter (TM5) × 2 ch 8-bit interval timer (BRG) × 1 ch		
Watchdog timer	2 ch				2 ch		
Serial interface	CSI with automatic transfer function (32-byte buffer) × 2 ch CSI × 2 ch UART × 2 ch I ² C × 1 ch ^{Note 4}				CSI with automatic transfer function (32-byte buffer) × 2 ch CSI × 3 ch UART/I ² C × 1 ch ^{Note 4} UART × 2 ch I ² C × 1 ch ^{Note 4}		
A/D converter	10-bit × 8 ch				10-bit × 16 ch		
D/A converter	8-bit × 2 ch				8-bit × 2 ch		
DMA controller	-				-		
Ports	I/O	76			112		
	Input	8			16		
Debug control unit	-				-		Provided (RUN/break)
Other peripheral functions	Watch timer: 1 ch, ROM correction function: 4 points, real-time output				Watch timer: 1 ch, ROM correction function: 4 points, real-time output		
Operating frequency	When using main clock: 2 to 20 MHz When using subclock: 32.768 kHz				When using main clock: 2 to 20 MHz When using subclock: 32.768 kHz		
Power supply voltage	2.7 V to 5.5 V				2.7 V to 5.5 V		
Power consumption (Typ.)	150 mW (128 KB mask products: 20 MHz @ 5 V operation) 29.7 mW (128 KB mask products: 10 MHz @ 3.3 V operation)				150 mW (128 KB mask products: 20 MHz @ 5 V operation) 29.7 mW (128 KB mask products: 10 MHz @ 3.3 V operation)		
Package	100-pin LQFP (14 × 14 mm) 100-pin QFP (14 × 20 mm)				144-pin LQFP (20 × 20 mm)		
Operating ambient temperature	-40 to +85°C				-40 to +85°C		

Notes 1. Number of external interrupts that can be used to release STOP mode
 2. μPD703215, 703215Y, 70F3215H, 70F3215HY only
 3. μPD70F3218H, 70F3218HY only
 4. Only Y products have an on-chip I²C interface.

Low-End Lineup (2/2)

Item	V850ES/KE1+		V850ES/KF1+	
	Part No.	μPD703302/3302Y	μPD70F3302/F3302Y	μPD70F3306/F3306Y
CPU core	V850ES		V850ES	
CPU performance	29 MIPS (@20 MHz: 5 MHz × 4)		29 MIPS (@20 MHz: 5 MHz × 4)	
Internal ROM	128 KB (mask)	128 KB (flash)	128 KB (flash)	256 KB (mask) 256 KB (flash)
Internal RAM	4 KB		6 KB	12 KB
External bus interface	Bus type	Multiplexed		
	Address bus	16 bits		
	Data bus	8/16 bits		
	Chip select signal	2		
Memory controller	-		SRAM, etc.	
Interrupt sources	Internal	26 (Y products: 27)		29 (Y products: 30)
	External	9(9) ^{Note 1}		9(9) ^{Note 1}
Timer/counter	16-bit timer/event counter (TMO) × 1 ch 16-bit timer/event counter (TMP) × 1 ch 8-bit timer (TMH) × 2 ch, 8-bit timer/event counter (TM5) × 2 ch, 8-bit interval timer (BRG) × 1 ch		16-bit timer/event counter (TMO) × 2 ch 16-bit timer/event counter (TMP) × 1 ch 8-bit timer (TMH) × 2 ch, 8-bit timer/event counter (TM5) × 2 ch, 8-bit interval timer (BRG) × 1 ch	
Watchdog timer	2 ch		2 ch	
Serial interface	CSI × 2ch UART × 1ch UART (LIN compatible) × 1 ch I ² C × 1 ch ^{Note 2}		CSI with automatic transfer function (32-byte buffer) × 1 ch CSI × 2 ch UART × 1 ch UART (LIN compatible) × 1 ch I ² C × 1 ch ^{Note 2}	
A/D converter	10-bit × 8 ch		10-bit × 8 ch	
D/A converter	-		-	
DMA controller	-		-	
Ports	I/O	43	59	
	Input	8	8	
Debug control unit	-		-	
Other peripheral functions	Watch timer: 1 ch, ROM correction function: 4 points, POC/LVI/clock monitor, real-time output		Watch timer: 1 ch, ROM correction function: 4 points, POC/LVI/clock monitor, real-time output	
Operating frequency	Using main clock: 2 to 20 MHz Using subclock: 32.768 kHz Ring-OSC: 240 kHz		Using main clock: 2 to 20 MHz Using subclock: 32.768 kHz Ring-OSC: 240 kHz	
Power supply voltage	2.7 to 5.5V		2.7 to 5.5V	
Power consumption (Typ.)	200 mW (128 KB mask products: 20 MHz @ 5 V operation) 39.6 mW (128 KB mask products: 10 MHz @ 3.3 V operation)		220 mW (256 KB mask products: 20 MHz @ 5 V operation) 42.9 mW (256 KB mask products: 10 MHz @ 3.3 V operation)	
Package	64-pin TQFP (12 × 12 mm) 64-pin LQFP (10 × 10 mm)		80-pin TQFP (12 × 12 mm) 80-pin QFP (14 × 14 mm)	
Operating ambient temperature	-40°C to +85°C		-40°C to +85°C	

Notes 1. Number of external interrupts that can be used to release STOP mode
2. Only Y products have an on-chip I²C interface.

Item	V850ES/KG1+		V850ES/KJ1+	
	Part No.	μPD70F3311/F3311Y	μPD703313/3313Y μPD70F3313/F3313Y	μPD70F3316/F3316Y
CPU core	V850ES		V850ES	
CPU performance	29 MIPS (@ 20 MHz : 5 MHz × 4)		29 MIPS (@ 20 MHz : 5 MHz × 4)	
Internal ROM	128 KB (flash)	256 KB (mask) 256 KB (flash)	128 KB (flash)	256 KB (flash)
Internal RAM	6 KB	16 KB	6 KB	16 KB
External bus interface	Bus type	Multiplexed/separate		
	Address bus	22 bits		
	Data bus	8/16 bits		
	Chip select signal	2		
Memory controller	SRAM, etc.		SRAM, etc.	
Interrupt sources	Internal	41 (Y products: 42)		46 (Y products: 48)
	External	9 (9) ^{Note 1}		9 (9) ^{Note 1}
Timer/counter	16-bit timer/event counter (TMO) × 4 ch 16-bit timer/event counter (TMP) × 1 ch 8-bit timer (TMH) × 2 ch, 8-bit timer/event counter (TM5) × 2 ch, 8-bit interval timer (BRG) × 1 ch		16-bit timer/event counter (TMO) × 6 ch 16-bit timer/event counter (TMP) × 1 ch 8-bit timer (TMH) × 2 ch, 8-bit timer/event counter (TM5) × 2 ch, 8-bit interval timer (BRG) × 1 ch	
Watchdog timer	2ch		2ch	
Serial interface	CSI with automatic transfer function (32-byte buffer) × 2 ch CSI × 1 ch UART/CSI × 1 ch UART × 1 ch UART (LIN compatible) × 1 ch I ² C × 1 ch ^{Note 2}		CSI with automatic transfer function (32-byte buffer) × 2 ch CSI × 2 ch UART ^{Note3} /CSI × 1 ch UART ^{Note3} /I ² C × 1 ch ^{Note2} UART (LIN compatible) × 1 ch UARTx: 1 ch, I ² C × 1 ch ^{Note 2}	
A/D converter	10-bit × 8 ch		10-bit × 16 ch	
D/A converter	8-bit × 2 ch		8-bit × 2 ch	
DMA controller	4 ch		4 ch	
Ports	I/O	76	112	
	Input	8	16	
Debug control unit	-		-	Provided (RUN/break)
Other peripheral functions	Watch timer: 1 ch, ROM correction function: 4 points, POC/LVI/clock monitor, real-time output		Watch timer: 1 ch, POC/LVI/clock monitor, real-time output	
Operating frequency	When using main clock: 2 to 20 MHz When using subclock: 32.768 kHz Ring-OSC: 240 kHz		When using main clock: 2 to 20 MHz When using subclock: 32.768 kHz Ring-OSC: 240 kHz	
Power supply voltage	2.7 to 5.5 V		2.7 to 5.5 V	
Power consumption (Typ.)	220 mW (256 KB mask products: 20 MHz @ 5 V operation) 42.9 mW (256 KB mask products: 10 MHz @ 3.3 V operation)		275 mW (256 KB flash products: 20 MHz @ 5 V operation) 59.4 mW (256 KB flash products: 10 MHz @ 3.3 V operation)	
Package	100-pin LQFP (14 × 14 mm) 100-pin QFP (14 × 20 mm)		144-pin LQFP (20 × 20 mm)	
Operating ambient temperature	-40°C to +85°C		-40°C to +85°C	

Notes 1. Number of external interrupts that can be used to release STOP mode
2. Only Y products have an on-chip I²C interface.
3. These UARTs are the identical and the number of channels in KJ1+ totals 3 channels.

Product Specifications List

Middle-Range Lineup (1/3)

Item		V850ES/SG2					
Part No.	Without IEBus, aFCAN	μPD703260/3260Y	μPD703261/3261Y	μPD70F3261/F3261Y	μPD703262/3262Y	μPD703263/3263Y	μPD70F3263/F3263Y
	On-chip IEBus	μPD703270/3270Y	μPD703271/3271Y	μPD70F3271/F3271Y	μPD703272/3272Y	μPD703273/3273Y	μPD70F3273/F3273Y
	On-chip aFCAN	μPD703280/3280Y	μPD703281/3281Y	μPD70F3281/F3281Y	μPD703282/3282Y	μPD703283/3283Y	μPD70F3283/F3283Y
CPU core		V850ES					
CPU performance		29 MIPS (@ 20 MHz)					
Internal ROM		256 KB (mask)	384 KB (mask)	384 KB (flash)	512 KB (mask)	640 KB (mask)	640 KB (flash)
Internal RAM		24 KB	32 KB		40 KB	48 KB	
External bus interface	Bus type	Multiplexed/separate					
	Address bus	22 bits					
	Data bus	8/16 bits					
	Chip select signal	-					
Memory controller		SRAM, etc.					
Interrupt sources	Internal	47 ^{Note 1} /52 ^{Note 2}					
	External	9(9) ^{Note 1}					
Timer/counter		16-bit interval timer(TMM) × 1 ch 16-bit timer/event counter(TMP) × 6 ch 16-bit timer/event counter(TMQ) × 1 ch					
Watchdog timer		1 ch					
Serial interface		CSI × 3 ch UART(LIN compatible)/CSI × 1 ch CSI/I ² C × 1 ch ^{Note 4} UART(LIN compatible)/I ² C × 2 ch ^{Note 4}					
A/D converter		10-bit × 12 ch					
D/A converter		8-bit × 2 ch					
DMA controller		4 ch					
Ports	I/O	84					
	Input	-					
Debug control unit		-	Provided (RUN/break)		-	Provided (RUN/break)	
Other peripheral functions		Watch timer: 1 ch IEBus controller × 1 ch ^{Note 5} aFCAN controller × 1 ch ^{Note 6} ROM correction function : 4 points Real-time output LVI/clock monitor					
Operating frequency		When using main clock: 2.5 to 20 MHz When using subclock: 32.768 kHz Ring-OSC: 200 kHz					
Power supply voltage		2.85 to 3.6 V (@ 20 MHz)					
Power consumption (Typ.)		59.4 mW(3.3 V, @ 20 MHz)	82.5 mW(3.3 V, @ 20 MHz)		59.4 mW(3.3 V, @ 20 MHz)	89.1 mW(3.3 V, @ 20 MHz)	
Package		100-pin LQFP (14 × 14 mm) 100-pin QFP (14 × 20 mm)					
Operating ambient temperature		-40°C to +85°C					

Notes 1. Only products without IEBus or aFCAN
2. Only products with IEBus or aFCAN
3. Number of external interrupts that can be used to release STOP mode

Notes 4. Only Y products have an on-chip I²C interface.
5. μPD703270 (Y)/3271 (Y)/F3271 (Y)/3272 (Y)/3273 (Y)/F3273 (Y)
6. μPD703280 (Y)/3281 (Y)/F3281 (Y)/3282 (Y)/3283 (Y)/F3283 (Y)

Item		V850ES/SG2					
Part No.	Without IEBus, aFCAN	μPD703260/3260Y	μPD703261/3261Y	μPD70F3261/F3261Y	μPD703262/3262Y	μPD703263/3263Y	μPD70F3263/F3263Y
	On-chip IEBus	μPD703270/3270Y	μPD703271/3271Y	μPD70F3271/F3271Y	μPD703272/3272Y	μPD703273/3273Y	μPD70F3273/F3273Y
	On-chip aFCAN	μPD703280/3280Y	μPD703281/3281Y	μPD70F3281/F3281Y	μPD703282/3282Y	μPD703283/3283Y	μPD70F3283/F3283Y
CPU core		V850ES					
CPU performance		29 MIPS (@ 20 MHz)					
Internal ROM		256 KB (mask)	384 KB (mask)	384 KB (flash)	512 KB (mask)	640 KB (mask)	640 KB (flash)
Internal RAM		24 KB	32 KB		40 KB	48 KB	
External bus interface	Bus type	Multiplexed/separate					
	Address bus	22 bits					
	Data bus	8/16 bits					
	Chip select signal	-					
Memory controller		SRAM, etc.					
Interrupt sources	Internal	47 ^{Note 1} /52 ^{Note 2}					
	External	9(9) ^{Note 1}					
Timer/counter		16-bit interval timer(TMM) × 1 ch 16-bit timer/event counter(TMP) × 6 ch 16-bit timer/event counter(TMQ) × 1 ch					
Watchdog timer		1 ch					
Serial interface		CSI × 3 ch UART(LIN compatible)/CSI × 1 ch CSI/I ² C × 1 ch ^{Note 4} UART(LIN compatible)/I ² C × 2 ch ^{Note 4}					
A/D converter		10-bit × 12 ch					
D/A converter		8-bit × 2 ch					
DMA controller		4 ch					
Ports	I/O	84					
	Input	-					
Debug control unit		-	Provided (RUN/break)		-	Provided (RUN/break)	
Other peripheral functions		Watch timer: 1 ch IEBus controller × 1 ch ^{Note 5} aFCAN controller × 1 ch ^{Note 6} ROM correction function : 4 points Real-time output LVI/clock monitor					
Operating frequency		When using main clock: 2.5 to 20 MHz When using subclock: 32.768 kHz Ring-OSC: 200 kHz					
Power supply voltage		2.85 to 3.6 V (@ 20 MHz)					
Power consumption (Typ.)		59.4 mW(3.3 V, @ 20 MHz)	82.5 mW(3.3 V, @ 20 MHz)		59.4 mW(3.3 V, @ 20 MHz)	89.1 mW(3.3 V, @ 20 MHz)	
Package		100-pin LQFP (14 × 14 mm) 100-pin QFP (14 × 20 mm)					
Operating ambient temperature		-40°C to +85°C					

Notes 1. Only products without IEBus or aFCAN
2. Only products with IEBus or aFCAN
3. Only products with two aFCAN channels
4. Number of external interrupts that can be used to release STOP mode

Notes 5. Only Y products have an on-chip I²C interface.
6. μPD703274 (Y)/F3274 (Y)/3275 (Y)/3276 (Y)/F3276 (Y)
7. μPD703284 (Y)/F3284 (Y)/3285 (Y)/3286 (Y)/F3286 (Y)
8. μPD703287 (Y)/3288 (Y)/F3288 (Y)

Middle-Range Lineup (2/3)

Item		V850/SB1					
Part No.	μPD703031B/3031BY	μPD703033B/3033BY	μPD70F3033B/F3033BY	μPD703030B/3030BY	μPD70F3030B/F3030BY	μPD703032B/3032BY	μPD70F3032B/F3032BY
CPU core	V850						
CPU performance	23 MIPS (@20 MHz)						
Internal ROM	128 KB (mask)	256 KB (mask)	256 KB (flash)	384 KB (mask)	384 KB (flash)	512 KB (mask)	512 KB (flash)
Internal RAM	8 KB	16 KB		24 KB			
External bus interface	Bus type	Multiplexed/separate					
	Address bus	22 bits					
	Data bus	16 bits					
	Chip select signal	-					
Memory controller	SRAM, etc.						
Interrupt sources	Internal	31 (Y products: 32)					
	External	8(6) ^{Note 1}					
Timer/counter	16-bit timer/event counter × 2 ch 8-bit timer/event counter × 6 ch 8-bit timer × 2 ch						
Watchdog timer	1 ch						
Serial interface	CSI × 1 ch CSI/I ² C × 2 ch ^{Note 2} CSI/UART × 2 ch						
A/D converter	10-bit × 12 ch						
D/A converter	-						
DMA controller	6 ch (dedicated internal RAM ← on-chip peripheral I/O)						
Ports	I/O	71					
	Input	12					
Debug control unit	-						
Other peripheral functions	ROM correction function: 4 points, watch timer: 1 ch						
Operating frequency	When using main clock: 2 to 20 MHz When using subclock: 32.768 kHz						
Power supply voltage	4.0 to 5.5 V (A/D converter: 4.5 to 5.5 V)						
Power consumption (Typ.)	125 mW (5 V, @ 20 MHz)	165 mW (5 V, @ 20 MHz)	125 mW (5 V, @ 20 MHz)	185 mW (5 V, @ 20 MHz)	125 mW (5 V, @ 20 MHz)	210 mW (5 V, @ 20 MHz)	
Package	100-pin LQFP (14 × 14 mm) 100-pin QFP (14 × 20 mm)				100-pin QFP (14 × 20 mm)		
Operating ambient temperature	-40 to +85°C						

Notes 1. Number of external interrupts that can be used to release STOP mode
2. Only Y products have an on-chip PC interface.

Item		μPD703229Y		V850/SC1	V850/SC2	V850/SC3		V850/SC1, V850/SC2, V850/SC3	
Part No.	μPD703229Y	μPD70F3229Y	μPD703068Y	μPD703069Y	μPD703088Y	μPD703089Y	μPD70F3089Y	μPD70F3089Y	
CPU core	V850ES		V850		V850				
CPU performance	29 MIPS (@ 20 MHz)		23 MIPS (@ 20 MHz)	21 MIPS (@ 19 MHz)	18 MIPS (@ 16 MHz)		23 MIPS (@ 20 MHz)		
Internal ROM	384 KB (mask)	384 KB (flash)	512 KB (mask)						512 KB (flash)
Internal RAM	32 KB		24 KB						
External bus interface	Bus type	Multiplexed							Multiplexed (can be separated only for V850/SC1, V850/SC2)
	Address bus	18 bits							22 bits
	Data bus	8/16 bits							16 bits
	Chip select signal	2							-
Memory controller	SRAM, etc.		SRAM, etc.						
Interrupt sources	Internal	38 sources	42	44	46	49			
	External	9 (9) ^{Note}	11 (9) ^{Note}						
Timer/counter	16-bit internal timer (TMM) × 1 ch 16-bit timer/event counter (TMP) × 4 ch 16-bit timer/event counter (TMQ) × 1 ch		16-bit timer/event counter × 10 ch						
Watchdog timer	1 ch		1 ch						
Serial interface	UART (LIN compatible) × 3 ch CSI × 1 ch CSI/I ² C × 1 ch		CSI × 2 ch CSI/I ² C × 2 ch CSI/UART × 2 ch UART × 2 ch						
A/D converter	10-bit × 12 ch		10-bit × 12 ch						
D/A converter	-		-						
DMA controller	4 ch		6 ch (dedicated internal RAM ← on-chip peripheral I/O)						
Ports	I/O	84							
	Input	-							
Debug control unit	-	Provided (RUN, break)	-						
Other peripheral functions	ROM correction function: 4 points, watch timer: 1 ch, LV1 clock monitor		ROM correction function: 4 points, watch timer: 1 ch, IEBus controller: 1 ch (V850/SC2 only), FCAN controller: 2 ch (1 ch: μPD703088Y only) (V850/SC3 only)						
Operating frequency	When using main clock: 2.5 to 20 MHz When using subclock: 32.768 kHz During Ring OSC operation: 200 kHz		When using main clock: 4 to 20 MHz (@5 V)	When using main clock: 4 to 19 MHz (@5 V)	When using main clock: 4 to 16 MHz (@5 V)		When using main clock: 4 to 20 MHz (@5 V)		
			When using subclock: 32.768 kHz	When using subclock: 32.768 kHz	When using subclock: 32.768 kHz		When using subclock: 32.768 kHz		
Power supply voltage	3.5 to 5.5V		3.5 to 5.5 V (A/D converter: 4.5 to 5.5 V)						4.0 to 5.5 V (A/D converter: 4.5 to 5.5 V)
Power consumption (Typ.)	100 mW (5 V, @ 20MHz)	145 mW (5 V, @ 20MHz)	125 mW (5 V, @ 20 MHz)	120 mW (5 V, @ 19 MHz)	110 mW (5 V, @ 16 MHz)		150 mW (5 V, @ 20 MHz)		
Package	100-pin LQFP (14 × 14 mm)		144-pin LQFP (20 × 20 mm)						
Operating ambient temperature	-40°C to +85°C		-40 to +85°C						

Note Number of external interrupts that can be used to release STOP mode

Product Specifications List

Middle-Range Lineup (3/3)

Item	V850ES/SA2			V850ES/SA3		V850ES/ST2
	μPD703200/3200Y	μPD703201/3201Y	μPD70F3201/F3201Y	μPD703204/3204Y	μPD70F3204/F3204Y	μPD703220
CPU core	V850ES					V850ES
CPU performance	29 MIPS (@ 20 MHz)					–
Internal ROM	128 KB (mask)	256 KB (mask)	256 KB (flash)	256 KB (mask)	256 KB (flash)	ROM-less
Internal RAM	8 KB	16 KB			48 KB	
External bus interface	Bus type	Multiplexed/separate				Separate/multiplexed (selectable only for CS1)
	Address bus	22 bits		24 bits		22 bits
	Data bus	8/16 bits				8/16 bits
	Chip select signal	4				4
Memory controller	SRAM, etc.					SRAM, etc.
Interrupt sources	Internal	30 (Y products: 31)		31 (Y products: 32)		28
	External	8 (8) ^{Note 1}				9
Timer/counter	16-bit timer/event counter × 2 ch 8-bit timer/event counter × 4 ch				16-bit interval timer (TMM) × 1 ch 16-bit timer/event counter (TMP) × 6 ch	
Watchdog timer	1 ch				1 ch	
Serial interface	CSI × 2 ch		CSI × 3 ch			CSI × 1 ch CSI/UART × 1 ch UART × 1 ch
	CSI/UART × 1 ch CSI/I ² C × 1 ch ^{Note 2} UART × 1 ch					
A/D converter	10-bit × 12 ch		10-bit × 16 ch			10-bit × 8 ch
D/A converter	8-bit × 2 ch				8-bit × 2 ch	
DMA controller	4 ch				–	
Ports	I/O	68		84		57
	Input	14		18		8
Debug control unit	–					–
Other peripheral functions	ROM correction function : 4 points, real-time counter (watch timer): 1 ch					Real-time output
Operating frequency	When using main clock: 2 to 20 MHz When using subclock: 32.768 kHz					20 to 34 MHz
Power supply voltage	2.2 to 2.7 V					3.0 to 3.6 V
Power consumption (Typ.)	38 mW (2.5 V, @ 20 MHz)		46 mW (2.5 V, @ 20 MHz)	38 mW (2.5 V, @ 20 MHz)	46 mW (2.5 V, @ 20 MHz)	T.B.D.
Package	100-pin TQFP (14 × 14 mm)			121-pin FBGA (12 × 12 mm)		120-pin TQFP (14 × 14 mm) 144-pin LQFP (20 × 20 mm)
Operating ambient temperature	-40°C to +85°C					-40°C to +85°C

Notes 1. Number of external interrupts that can be used to release STOP mode
2. Only Y products have an on-chip I²C interface.

Item	V850/SA1								
	μPD703014A/3014AY	μPD703014B/3014BY	μPD703015A/3015AY	μPD703015B/3015BY	μPD70F3015B/F3015BY	μPD703017A/3017AY	μPD70F3017A/F3017AY		
CPU core	V850								
CPU performance	23 MIPS (@ 20 MHz)								
Internal ROM	64 KB (mask)	128 KB (mask)		128 KB (flush)	256 KB (mask)	256 KB (flash)			
Internal RAM	4 KB				8 KB				
External bus interface	Bus type	Multiplexed/separate							
	Address bus	22 bits							
	Data bus	16 bits							
	Chip select signal	–							
Memory controller	SRAM, etc.								
Interrupt sources	Internal	24							
	External	8 (5) ^{Note 1}							
Timer/counter	16-bit timer/event counter × 2 ch 8-bit timer/event counter × 4 ch								
Watchdog timer	1 ch								
Serial interface	CSI × 1 ch, CSI/I ² C × 1 ch ^{Note 2} CSI/UART × 1 ch UART × 1 ch								
	10-bit × 12 ch								
A/D converter	–								
D/A converter	–								
DMA controller	3 ch (dedicated internal RAM ← on-chip peripheral I/O)								
Ports	I/O	72							
	Input	13							
Debug control unit	–								
Other peripheral functions	Watch timer: 1 ch								
Operating frequency	When using main clock: 2 to 20 MHz When using subclock: 32.768 kHz								
Power supply voltage	3.0 to 3.6 V (@ 20 MHz) 2.7 to 3.6 V (@ 17 MHz)								
Power consumption (Typ.)	66 mW (3.3 V, @ 20 MHz) 56 mW (3.0 V, @ 17 MHz)			105 mW (3.3 V, @ 20 MHz) 99 mW (3.0 V, @ 17 MHz)	66 mW (3.3 V, @ 20 MHz) 56 mW (3.0 V, @ 17 MHz)	105 mW (3.3 V, @ 20 MHz) 99 mW (3.0 V, @ 17 MHz)			
Package	121-pin FBGA (12 × 12 mm)	100-pin LQFP (14 × 14 mm)	121-pin FBGA (12 × 12 mm)	100-pin LQFP (14 × 14 mm)		100-pin LQFP (14 × 14 mm) 121-pin FBGA (12 × 12 mm)			
Operating ambient temperature	-40°C to +85°C								

Notes 1. Number of external interrupts that can be used to release STOP mode
2. Only Y products have an on-chip I²C interface.

ASSP Lineup (1/3)

Item	V850E/IA4			V850E/IA3		V850E/IA1		V850E/IA2		
	Part No.	μPD703185	μPD703186	μPD70F3186	μPD703183	μPD70F3184	μPD703116	μPD70F3116	μPD703114	μPD70F3114
CPU core	V850E1			V850E1		V850E1		V850E1		
CPU performance	82 MIPS (@ 64 MHz)			82 MIPS (@ 64 MHz)		67 MIPS (@ 50 MHz)		54 MIPS (@ 40 MHz)		
Internal ROM	128 KB (mask)	256 KB (mask)	256 KB (flash)	128 KB (mask)	256 KB (flash)	256 KB (mask)	256 KB (flash)	128 KB (mask)	128 KB (flash)	
Internal RAM	6 KB	12 KB		6 KB	12 KB	10 KB		6 KB		
External bus interface	Bus type	-			-		Multiplexed		Multiplexed	
	Address bus	-			-		24 bits		22 bits	
	Data bus	-			-		8/16 bits		8/16 bits	
	Chip select signal	-			-		8		-	
Memory controller	-			-		SRAM, etc.		SRAM, etc.		
Interrupt sources	Internal	53		49		45		42		
	External	8 (7) ^{Note}		7 (6) ^{Note}		20(14) ^{Note}		16(12) ^{Note}		
Timer/counter	16-bit timer/event counter (TMQ) × 2 ch (inverter timer support possible) 16-bit encoder counter/timer (TMENC) × 2 ch 16-bit timer/event counter (TMP) × 2 ch 16-bit timer/counter (TMM) × 2 ch 16-bit interval timer (TMM) × 1 ch			16-bit timer/event counter (TMQ) × 1 ch (inverter timer support possible) 16-bit encoder counter/timer (TMENC) × 1 ch 16-bit timer/event counter (TMP) × 2 ch 16-bit timer/event counter (TMQ) × 1 ch 16-bit timer/counter (TMM) × 2 ch 16-bit interval timer (TMM) × 1 ch		16-bit 3-phase sinusoidal PWM timer × 2 ch 16-bit encoder counter/timer × 2 ch 16-bit timer/counter × 2 ch 16-bit timer/event counter × 1 ch 16-bit interval timer × 1 ch		16-bit 3-phase sinusoidal PWM timer × 2 ch 16-bit encoder counter/timer × 1 ch 16-bit timer/counter × 2 ch 16-bit timer/event counter × 1 ch 16-bit interval timer × 1 ch		
Watchdog timer	1 ch			1 ch		-		-		
Serial interface	CSI × 1 ch UART × 1 ch CSI/UART × 1 ch			CSI × 1 ch UART × 1 ch CSI/UART × 1 ch		CSI × 2 ch UART × 3 ch		CSI × 1 ch CSI/UART × 1 ch UART × 1 ch		
A/D converter	10-bit × 4 ch, 2 units (conversion time: 2 μs) 8/10-bit × 8 ch			10-bit × 4 ch, 10-bit × 2 ch (conversion time: 2 μs) 8/10-bit × 6 ch		10-bit × 8 ch, 2 units		10-bit × 6 ch (A/D converter 0) 10-bit × 8 ch (A/D converter 1)		
D/A converter	-			-		-		-		
DMA controller	4 ch			4 ch		4 ch		4 ch		
Ports	I/O	56		44		75		47		
	Input	8		6		8		6		
Debug control unit	-			Provided (RUN/break)		-		-		
Other peripheral functions	ROM correction function : 4 points, operational amplifier, comparator, software pull-up function			ROM correction function : 4 points, operational amplifier, comparator, software pull-up function		FCAN controller × 1 ch		-		
Operating frequency	0.5 to 64 MHz			0.5 to 64 MHz		4 to 50 MHz		4 to 40 MHz		
Power supply voltage	2.5 V (internal), 5 V (A/D converter) 5 V (external)			2.5 V (internal), 5 V (A/D converter) 5 V (external)		3.3 V (internal), 5 V (A/D converter) 5 V (external)		5 V (3.3 V (internal), 5 V (A/D converter)) 5 V (external) (on-chip regulator)		
Power consumption (Typ.)	175 mW (internal 2.5 V, @ 64 MHz)			175 mW (internal 2.5 V, @ 64 MHz)		630 mW (internal 3.3 V, external 5 V, @ 50 MHz operation)		440 mW (5 V, @ 40 MHz operation)		
Package	100-pin LQFP (14 × 14 mm) 100-pin QFP (14 × 20 mm)			80-pin QFP (14 × 14 mm)		144-pin LQFP (20 × 20 mm)		100-pin QFP (14 × 20 mm) 100-pin LQFP (14 × 14 mm)		
Operating ambient temperature	-40°C to +85°C			-40°C to +85°C		-40°C to +85°C (Provided 110°C products)		-40°C to +85°C		

Note Number of external interrupts that can be used to release STOP mode.

Item	V850ES/IK1			V850/SB2			
	Part No.	μPD703327	μPD703329 μPD70F3329	μPD703034B/3034BY	μPD703035B/3035BY μPD70F3035B/F3035BY	μPD703036H/3036HY μPD70F3036H/F3036HY	μPD703037H/3037HY μPD70F3037H/F3037HY
CPU core	V850ES			V850			
CPU performance	41MIPS (@ 32 MHz)			15 MIPS (@ 13 MHz)		22MIPS (@ 19 MHz)	
Internal ROM	64 KB (mask)	128 KB (mask)	128 KB (flash)	256 KB (mask)	256 KB (flash)	384 KB (mask)	512 KB (mask)
Internal RAM	4 KB	6 KB	8 KB	16 KB	24 KB		
External bus interface	Bus type	-			Multiplexed/separate		
	Address bus	-			22 bits		
	Data bus	-			16 bits		
	Chip select signal	-			-		
Memory controller	-			SRAM, etc.			
Interrupt sources	Internal	36		33 (Y products : 34)			
	External	7 (6) ^{Note 1}		8 (6) ^{Note 1}			
Timer/counter	16-bit timer/event counter (TMQ) × 1 ch (inverter timer support possible) 16-bit timer/event counter (TMP) × 1 ch 16-bit timer/event counter (TMQ) × 1 ch 16-bit timer counter (TMP) × 3 ch 16-bit interval timer (TMM) × 1 ch			16-bit timer/event counter × 2 ch 8-bit timer/event counter × 4 ch 8-bit timer × 2 ch			
Watchdog timer	1 ch			1 ch			
Serial interface	CSI × 1 ch UART × 2 ch			CSI × 1 ch CSI/I ² C × 2 ch ^{Note 2} CSI/UART × 2 ch			
A/D converter	10 bits × 4 ch, 2 units (conversion time 2 μs)			10-bit × 12 ch			
D/A converter	-			-			
DMA controller	-			6 ch (dedicated internal RAM ←→ on-chip peripheral I/O)			
Ports	I/O	39		71			
	Input	-		12			
Debug control unit	-			-			
Other peripheral functions	ROM correction function : 4 points, software pull-up function, POCLV/clock monitor			ROM correction function : 4 points, watch timer × 1 ch, IEBus controller (simple version) : 1 ch			
Operating frequency	20 to 32 MHz			When using main clock: 2 to 13 MHz (@ 5 V) When using subclock: 32.768 kHz		When using main clock: 2 to 19 MHz (@ 5 V) When using subclock: 32.768 kHz	
Power supply voltage	3.5 to 5.5 V (A/D converter : 4.5 to 5.5 V)			4.0 to 5.5 V (A/D converter : 4.5 to 5.5 V)			
Power consumption (Typ.)	T.B.D.			75 mW (mask ROM version : @ 5 V, 13 MHz) 125 mW (flash memory version : @ 5 V, 13 MHz)		125 mW (mask ROM version : @ 5 V, 19 MHz) 185 mW (flash memory version : @ 5 V, 19 MHz)	
Package	64-pin LQFP (14 × 14 mm)			100-pin LQFP (14 × 14 mm) 100-pin QFP (14 × 20 mm)		100-pin QFP (14 × 20 mm)	
Operating ambient temperature	-40°C to +85°C			-40°C to +85°C			

Notes 1. Number of external interrupts that can be used to release STOP mode.

2. Only Y products have an on-chip I²C interface.

Product Specifications List

ASSP Lineup (2/3)

Item	V850ES/FE2				V850ES/FF2				
	Part No.	μPD703230	μPD70F3230	μPD703231	μPD70F3231	μPD703232	μPD70F3232	μPD703233	μPD70F3233
CPU core	V850ES				V850ES				
CPU performance	29 MIPS (@20 MHz)				29 MIPS (@20 MHz)				
Internal ROM	64 KB (mask)	64 KB (flash)	128 KB (mask)	128 KB (flash)	128 KB (mask)	128 KB (flash)	256 KB (mask)	256 KB (flash)	
Internal RAM	4 KB		6 KB		6 KB		12 KB		
External bus interface	Bus type	-			-			-	
	Address bus	-			-			-	
	Data bus	-			-			-	
	Chip select signal	-			-			-	
Memory controller	-				-				
Interrupt sources	Internal	44			44			-	
	External	9(9) ^{Note}			9(9) ^{Note}			-	
Timer/counter	16-bit timer/event counter (TMP) × 4 ch 16-bit timer/event counter (TMQ) × 1 ch 16-bit interval timer (TMM) × 1 ch				16-bit timer/event counter (TMP) × 4 ch 16-bit timer/event counter (TMQ) × 1 ch 16-bit interval timer (TMM) × 1 ch				
Watchdog timer	1 ch				1 ch				
Serial interface	CSI × 2 ch UART (LIN compatible) × 2 ch				CSI × 2 ch UART (LIN compatible) × 2 ch				
A/D converter	10-bit × 10 ch				10-bit × 12 ch				
D/A converter	-				-				
DMA controller	-				-				
Ports	I/O	51			67			-	
	Input	-			-			-	
Debug control unit	-	Provided (RUN, break)	-	Provided (RUN, break)	-	Provided (RUN, break)	-	Provided (RUN, break)	
Other peripheral functions	Watch timer: 1 ch, on-chip POC/LVI, RAM hold flag, aFCAN controller: 1 ch				Watch timer: 1 ch, on-chip POC/LVI, RAM hold flag, aFCAN controller: 1 ch				
Operating frequency	When using main clock: 16 to 20 MHz				When using main clock: 16 to 20 MHz				
Power supply voltage	4.0 to 5.5V				4.0 to 5.5V				
Power consumption (Typ.)	155 mW (@5.0 V, 20 MHz)	170 mW (@5.0 V, 20 MHz)	155 mW (@5.0 V, 20 MHz)	170 mW (@5.0 V, 20 MHz)	155 mW (@5.0 V, 20 MHz)	170 mW (@5.0 V, 20 MHz)	155 mW (@5.0 V, 20 MHz)	170 mW (@5.0 V, 20 MHz)	
Package	64-pin TQFP (10 × 10 mm)				80-pin TQFP (12 × 12mm)				
Operating ambient temperature	-40°C to +85°C, -40°C to +110°C				-40°C to +85°C, -40°C to +110°C				

Note Number of external interrupts that can be used to release STOP mode

Item	V850ES/FG2					V850ES/FJ2			
	Part No.	μPD703234	μPD70F3234	μPD703235	μPD70F3235	μPD70F3236	μPD70F3237	μPD70F3238	μPD70F3239
CPU core	V850ES					V850ES			
CPU performance	29 MIPS (@ 20 MHz)					29 MIPS (@ 20 MHz)			
Internal ROM	128 KB (mask)	128 KB (flash)	256 KB (mask)	256 KB (flash)	384 KB (flash)	256 KB (flash)	384 KB (flash)	512 KB (flash)	
Internal RAM	6 KB		12 KB		16 KB	12 KB	16 KB	20 KB	
External bus interface	Bus type	-			-			Multiplexed	
	Address bus	-			-			16 bits	
	Data bus	-			-			8/16 bits	
	Chip select signal	-			-			4	
Memory controller	-					-			
Interrupt sources	Internal	62			73			83	
	External	12 (12) ^{Note}			16 (16) ^{Note}			-	
Timer/counter	16-bit timer/event counter (TMP) × 4 ch 16-bit timer/event counter (TMQ) × 2 ch 16-bit interval timer (TMM) × 1 ch					16-bit timer/event counter (TMP) × 4 ch 16-bit timer/event counter (TMQ) × 3 ch 16-bit interval timer (TMM) × 1 ch			
Watchdog timer	1 ch					1ch			
Serial interface	CSI × 2 ch UART (LIN compatible) × 3 ch					CSI × 3 ch UART (LIN compatible) × 3 ch		CSI × 3 ch UART (LIN compatible) × 4 ch	
A/D converter	10-bit × 16 ch					10-bit × 24 ch			
D/A converter	-					-			
DMA controller	4 ch					4 ch			
Ports	I/O	84			128			-	
	Input	-			-			-	
Debug control unit	-	Provided (RUN, break)	-	Provided (RUN, break)	Provided (RUN, break)				
Other peripheral functions	Watch timer: 1 ch, on-chip POC/LVI, RAM hold flag, aFCAN controller: 2 ch					Watch timer: 1 ch, on-chip POC/LVI, RAM hold flag aFCAN controller: 2 ch			aFCAN controller: 4 ch
Operating frequency	When using main clock: 16 to 20 MHz					When using main clock: 16 to 20 MHz			
Power supply voltage	4.0 to 5.5V					4.0 to 5.5V			
Power consumption (Typ.)	155 mW (@ 5.0 V, 20 MHz)	170 mW (@ 5.0 V, 20 MHz)	155 mW (@ 5.0 V, 20 MHz)	170 mW (@ 5.0 V, 20 MHz)		200 mW (@ 5.0 V, 20 MHz)			
Package	100-pin LQFP (14 × 14 mm)					144-pin LQFP (20 × 20 mm)			
Operating ambient temperature	-40°C to +85°C, -40°C to +110°C					-40°C to +85°C, -40°C to +110°C			

Note Number of external interrupts that can be used to release STOP mode

ASSP Lineup (3/3)

Item	V850E/SV2				V850/SV1							
	Part No.	μPD703166/3166Y	μPD70F3166/F3166Y	μPD703041/3041Y	μPD703039/3039Y	μPD703040/3040Y	μPD70F3040/F3040Y	μPD703038/3038Y	μPD70F3038/F3038Y			
CPU core	V850E1				V850							
CPU performance	55 MIPS (@ 40.5 MHz)				23 MIPS (@ 20 MHz)							
Internal ROM	512 KB (mask)		512 KB (flash)		192 KB (mask)		256 KB (mask)		384 KB (mask)		384 KB (flash)	
Internal RAM	24 KB				8 KB				16 KB			
External bus interface	Bus type	Multiplexed/separate				Multiplexed						
	Address bus	26 bits				22 bits						
	Data bus	8/16 bits				16 bits						
	Chip select signal	8				-						
Memory controller	SRAM, etc.				SRAM, etc.							
Interrupt sources	Internal	75 (Y products : 76)				45 (Y products: 46)						
	External	12(12) ^{Note 1}				9(6) ^{Note 1}						
Timer/counter	32-bit timer/event counter × 1 ch 16-bit timer/event counter × 6 ch 16-bit interval timer × 6 ch 8-bit timer/event counter × 12 ch				24-bit timer/event counter × 2 ch 16-bit timer/event counter × 2 ch 8-bit timer/event counter × 8 ch							
Watchdog timer	1 ch				1 ch							
Serial interface	CSI with automatic transfer function × 2 ch CSI × 3 ch UART/CSI × 1 ch UART × 1 ch I ² C × 1 ch ^{Note 2}				CSI × 1 ch CSI/I ² C × 2 ch ^{Note 2} CSI/UART × 2ch							
A/D converter	10-bit × 24 ch				10-bit × 16 ch							
D/A converter	-				-							
DMA controller	4 ch				6 ch (dedicated internal RAM ←→ internal peripheral I/O)							
Ports	I/O	171				135						
	Input	24				16						
Debug control unit	Provided (RUN, break)				-							
Other peripheral functions	Boundary scan function, 12- to 16-bit PWM output : 5 ch, real-time output, ROM correction function : 8 points				Watch timer: 1 ch, 12- to 16-bit PWM output : 4 ch, V _{sync} /H _{sync} separator, ROM correction function : 4 points							
Operating frequency	10 to 40.5 MHz				When using main clock: 4 to 20 MHz When using subclock: 32.768 kHz							
Power supply voltage	2.3 to 2.7 V (internal) 2.7 to 3.6 V (external)				3.1 to 3.6 V (@ 20 MHz) 2.7 to 3.6 V (@ 16 MHz)							
Power consumption (Typ.)	134 mW (@ 2.5 V, 40.5 MHz)		159 mW (@ 2.5 V, 40.5 MHz)		82 mW (@ 3.3 V, 20 MHz)		148 mW (@ 3.3 V, 20 MHz)		82 mW (@ 3.3 V, 20 MHz)		148 mW (@ 3.3 V, 20 MHz)	
Package	257-pin FBGA (14 × 14 mm)				176-pin LQFP (24 × 24 mm)		176-pin LQFP (24 × 24 mm) 180-pin FBGA (13 × 13 mm)		180-pin FBGA (13 × 13 mm)			
Operating ambient temperature	-10°C to +70°C				-40°C to +85°C							

Notes 1. Number of external interrupts that can be used to release STOP mode
2. Only Y products have an on-chip I²C interface.

Item	V850/SF1				V850/DB1		V850ES/PM1								
	Part No.	μPD703075AY	μPD703076AY	μPD703078AY	μPD703079AY	μPD70F3079AY	μPD70F3080	μPD703081	μPD703228						
CPU core	V850							V850ES							
CPU performance	18 MIPS (@ 16 MHz)							18 MIPS (@ 16 MHz)		29 MIPS (@ 20 MHz)					
Internal ROM	128 KB (mask)		256 KB (mask)		256 KB (flash)		128 KB (flash)		128 KB (mask)		128 KB (mask)/ROM-less				
Internal RAM	12 KB		16 KB		6 KB		6 KB		10 KB						
External bus interface	Bus type	Multiplexed							-		Separate				
	Address bus	22 bits							-		19 bits				
	Data bus	16 bits							-		8/16 bits				
	Chip select signal	-							-		3				
Memory controller	SRAM, etc.							-		SRAM, etc.					
Interrupt sources	Internal	35		38		35		38		44		40		28	
	External	8 (6) ^{Note}							7 (7) ^{Note 1}		7 (7) ^{Note 1}		4 (4) ^{Note 1}		
Timer/counter	16-bit timer/event counter × 8 ch							16-bit timer/event counter (TMG) × 1 ch 16-bit timer/event counter (TM0) × 2 ch 8-bit timer/event counter (TM5) × 2 ch		16-bit timer/event counter (TM1) × 6 ch 8-bit timer/event counter (TM2) × 2 ch					
Watchdog timer	1 ch							1 ch		1 ch					
Serial interface	CSI × 1 ch CSI/I ² C × 1 ch CSI/UART × 2 ch							CSI × 3 ch UART × 2 ch		CSI × 2 ch UART × 2ch					
A/D converter	10-bit × 12 ch							10-bit × 8 ch		16-bit × 6 ch (12 inputs)					
D/A converter	-							-		-					
DMA controller	6 ch (dedicated internal RAM ←→ internal peripheral I/O)							-		-					
Ports	I/O	72							99 (Including 16 output-only)		68				
	Input	12							8		-				
Debug control unit	-							-		-					
Other peripheral functions	Watch timer: 1 ch FCAN controller : 1 ch ROM correction function : 4 points	Watch timer: 1 ch FCAN controller : 2 ch ROM correction function : 4 points	Watch timer: 1 ch FCAN controller : 1 ch ROM correction function : 4 points	Watch timer: 1 ch FCAN controller : 2 ch ROM correction function : 4 points	Watch timer: 1 ch FCAN controller : 2 ch ROM correction function : 4 points	Watch timer: 1 ch, 16-bit PWM output: 6 ch 8-bit PWM output: 2 ch, meter control PWM: 24 ch DCAN controller: 2 ch	Watch timer: 1 ch, 16-bit PWM output: 6 ch 8-bit PWM output: 2 ch, meter control PWM: 24 ch DCAN controller: 1 ch	Real-time counter (watch timer) : 1 ch ROM correction function : 4 points 8- to 12-bit PWM output : 4 ch							
Operating frequency	When using main clock: 4 to 16 MHz When using subclock: 32.768 kHz							When using main clock: 4 to 16 MHz		When using main clock: 2 to 20 MHz When using subclock: 32.768 kHz					
Power supply voltage	3.5 to 5.5 V (A/D converter: 4.5 to 5.5 V)							4.0 to 5.5 V		3.0 to 3.6 V (@ 20 MHz) 2.7 to 3.6 V (@ 10 MHz) 2.2 to 3.6 V (@ 32.768 kHz)					
Power consumption (Typ.)	75 mW (@ 5 V, 16 MHz)				125 mW (@ 5 V, 16 MHz)		180 mW (@ 5 V, 16 MHz)		120 mW (@ 5 V, 16 MHz)		81 mW (@ 3.3 V, 20 MHz)				
Package	100-pin LQFP (14 × 14 mm) 100-pin QFP (14 × 20 mm)				128-pin QFP (20 × 20 mm)		128-pin QFP (20 × 20 mm)		100-pin LQFP (14 × 14 mm)						
Operating ambient temperature	-40°C to +85°C							-40°C to +85°C		-40°C to +85°C					

Note Number of external interrupts that can be used to release STOP mode

Product Specifications List

High-End Lineup (1/2)

Item	V850E/MA3					V850E/ME2
Part No.	μPD703131A/3131AY	μPD703132A/3132AY	μPD703133A/3133AY	μPD703134A/3134AY	μPD70F3134A/F3134AY	μPD703111A
CPU core	V850E1					V850E1
CPU performance	106 MIPS (@ 80 MHz)					215 MIPS (@ 150 MHz)
Internal ROM	256 KB (mask)		512 KB (mask)		512 KB (flash)	ROM-less (instruction cache : 8 KB)
Internal RAM	16 KB	32 KB	16 KB	32 KB		Instruction: 128 KB; Data: 16 KB
External bus interface	Bus type	Multiplexed/separate				Separate
	Address bus	26 bits				26 bits
	Data bus	8/16 bits				8/16/32 bits
	Chip select signal	8				8
Memory controller	SDRAM, SRAM, etc.					SDRAM, SRAM, etc.
Interrupt sources	Internal	41				59
	External	26(26) ^{Note 1}				40(32) ^{Note 1}
Timer/counter	16-bit interval timer (TMD) × 4 ch 16-bit timer/event counter (TMP) × 3 ch 16-bit timer/event counter (TMQ) × 1 ch (inverter timer support possible) 16-bit encoder counter/timer (TMENC) × 1 ch					16-bit timer/event counter (TMC) × 6 ch 16-bit interval timer (TMD) × 4 ch 16-bit encoder counter/timer (TMENC) × 2 ch
Watchdog timer	1 ch					-
Serial interface	CSI/UART × 3 ch UART/I ² C × 1 ch ^{Note 2}					CSI (with FIFO) × 1 ch CSI (with FIFO)/UART × 1 ch UART × 1 ch
A/D converter	10-bit × 8 ch					10-bit × 8 ch
D/A converter	8-bit × 2 ch					-
DMA controller	4 ch					4 ch
Ports	I/O	101				77
	Input	11				1
Debug control unit	Provided (RUN, break)					Provided (RUN, break, trace)
Other peripheral functions	ROM correction function : 4 points					USB (function) × 1 ch, SSCG 16-bit PWM output × 2 ch
Operating frequency	5 to 80 MHz					10 to 150 MHz
Power supply voltage	2.3 to 2.7 V (internal)/3.0 to 3.6 V (external)					1.35 to 1.65 V (internal)/3.0 to 3.6 V (external) (@ 133 MHz) 1.40 to 1.65 V (internal)/3.0 to 3.6 V (external) (@ 150 MHz)
Power consumption (Typ.)	T.B.D.				575 mW (@ 2.5 V, 80 MHz)	200 mW (@ 1.5 V, 150 MHz)
Package	144-pin LQFP (20 × 20 mm) 161-pin FBGA (13 × 13 mm)					176-pin LQFP (24 × 24 mm) 240-pin FBGA (16 × 16 mm)
Operating ambient temperature	-40°C to +85°C					-40°C to +85°C (@133MHz), -40 to°C +70°C (@150MHz)

Notes 1. Number of external interrupts that can be used to release STOP mode
2. Only Y products have an on-chip I²C interface.

Item	V850E/MA1					V850E/MA2
Part No.	μPD703103A	μPD703105A	μPD703106A	μPD703107A	μPD70F3107A	μPD703108
CPU core	V850E1					V850E1
CPU performance	-	67 MIPS (@ 50 MHz)				-
Internal ROM	ROM-less	128 KB (mask)		256 KB (mask)	256 KB (flash)	ROM-less
Internal RAM	4 KB		10 KB			4 KB
External bus interface	Bus type	Separate				Separate
	Address bus	26 bits				25 bits
	Data bus	8/16 bits				8/16 bits
	Chip select signal	8				4
Memory controller	SDRAM, SRAM, etc.					SDRAM, SRAM, etc.
Interrupt sources	Internal	33				23
	External	25 (17) ^{Note}				8 (4) ^{Note}
Timer/counter	16-bit timer/event counter (TMC) × 4 ch 16-bit interval timer (TMD) × 4 ch					16-bit timer/event counter (TMC) × 2 ch 16-bit interval timer (TMD) × 4 ch
Watchdog timer	-					-
Serial interface	CSI × 1 ch CSI/UART × 2 ch UART × 1 ch					CSI/UART × 2 ch
A/D converter	10-bit × 8 ch					10-bit × 4 ch
D/A converter	-					-
DMA controller	4 ch					4 ch
Ports	I/O	106				74
	Input	9				5
Debug control unit	-					-
Other peripheral functions	12-bit PWM output × 2ch					-
Operating frequency	4 to 50 MHz					4 to 40 MHz
Power supply voltage	3.0 to 3.6 V					3.0 to 3.6 V
Power consumption (Typ.)	528 mW (@ 3.3 V, 50 MHz)				627 mW (@ 3.3 V, 50 MHz)	416 mW (@ 3.3 V, 40 MHz)
Package	144-pin LQFP (20 × 20 mm)		144-pin LQFP (20 × 20 mm) 161-pin FBGA (13 × 13 mm)			100-pin LQFP (14 × 14 mm)
Operating ambient temperature	-40°C to +85°C					-40°C to +85°C

Note Number of external interrupts that can be used to release STOP mode

High-End Lineup (2/2)

Item		V850E/MS1				V850E/MS2
Part No.	External 3.3V	μPD703100A-33/-40	μPD703101A-33	μPD703102A-33	μPD70F3102A-33	μPD703130
	External 5V	μPD703100-33/-40	μPD703101-33	μPD703102-33	μPD70F3102-33	
CPU core		V850E1				V850E1
CPU performance		47 MIPS (@ 33 MHz)				-
Internal ROM		ROM-less	96 KB (mask)	128 KB (mask)	128 KB (flash)	ROM-less
Internal RAM		4 KB				4 KB
External bus interface	Bus type	Separate				Separate
	Address bus	24 bits				24 bits
	Data bus	8/16 bits				8/16 bits
	Chip select signal	8				4
Memory controller		EDO DRAM, SRAM, etc.				EDO DRAM, SRAM, etc.
Interrupt sources	Internal	47				35
	External	25 (1) ^{Note1}				10 (1) ^{Note1}
Timer/counter		16-bit timer/event counter × 6 ch 16-bit interval timer × 2 ch				16-bit timer/event counter × 4 ch 16-bit interval timer × 2 ch
Watchdog timer		-				-
Serial interface		CSI × 2 ch CSI/UART × 2 ch				CSI/UART × 2ch
A/D converter		10-bit × 8 ch				10-bit × 4 ch
D/A converter		-				-
DMA controller		4ch				4 ch
Ports	I/O	122				52
	Input	9				5
Debug control unit		-				-
Other peripheral functions		-				-
Operating frequency		2 to 40 MHz (-40 product) 2 to 33 MHz (-33 product)				10 to 33 MHz
Power supply voltage		3.0 to 3.6 V (internal, external) (A products) 3.0 to 3.6 V (internal)/4.5 to 5.5 V (external) (Products without A)				3.0 to 3.6 V (internal)/ 4.5 to 5.5 V (external)
Power consumption (Typ.)		272 mW (@ 3.3 V, 33 MHz) 430 mW (@ 5 V, 33 MHz)		294 mW (@ 3.3 V, 33 MHz) 515 mW (@ 5 V, 33 MHz)		218 mW (@ 3.3 V, 33 MHz)
Package		144-pin LQFP (20 × 20 mm) 157-pin FBGA (14 × 14 mm) ^{Note2}				100-pin LQFP (14 × 14 mm)
Operating ambient temperature		-40°C to +85°C ^{Note3}				-40°C to +85°C

Notes 1. Number of external interrupts that can be used to release STOP mode
 2. μPD703100A-33, 703101A-33, 703102A-33, and 70F3102A-33 only
 3. μPD703100-40, 703100A-40 : -40°C to +70°C
 Others : -40°C to +85°C

Item		V853				
Part No.		μPD703003A	μPD703004A	μPD703025A	μPD70F3003A	μPD70F3025A
	CPU core		V850			
CPU performance		38 MIPS (@ 33 MHz)				
Internal ROM		128 KB (mask)	96 KB (mask)	256 KB (mask)	128 KB (flash)	256 KB (flash)
Internal RAM		4 KB		8 KB	4 KB	8 KB
External bus interface	Bus type	Multiplexed				
	Address bus	20 bits				
	Data bus	16 bits				
	Chip select signal	-				
Memory controller		SRAM, etc.				
Interrupt sources	Internal	32				
	External	17(1) ^{Note}				
Timer/counter		16-bit timer/event counter × 4 ch 16-bit interval timer × 1 ch				
Watchdog timer		-				
Serial interface		CSI × 2 ch CSI/UART × 2 ch				
A/D converter		10 bits × 8 ch				
D/A converter		2 ch				
DMA controller		-				
Ports	I/O	67				
	Input	8				
Debug control unit		-				
Other peripheral functions		12-bit PWM output × 2 ch				
Operating frequency		2 to 33 MHz				
Power supply voltage		4.5 to 5.5V				
Power consumption (Typ.)		365 mW (@ 5 V, 33 MHz)		450 mW (@ 5 V, 33 MHz)	425 mW (@ 5 V, 33 MHz)	480 mW (@ 5 V, 33 MHz)
Package		100-pin LQFP (14 × 14 mm)				
Operating ambient temperature		-40°C to +85°C				

Note Number of external interrupts that can be used to release STOP mode

V850 Series Development Environment

The V850 Series development environment consists of tools designed to make the development of application systems using the V850 Series of high-performance microcontrollers made by NEC Electronics more pleasant, faster, and more accurate.

Each one of these development tools features functions to fully exploit the performance of the V850 Series.



Low-Priced Development Environment Lineup

Emulator and evaluation board available at low prices

Price

Low-priced full-function emulator IECUBE

- Low prices 1/3 or 1/4 the price of conventional emulators
- Connectable to PC via USB
- Enhanced real-time RAM monitor and time measuring function
- On-chip self-diagnosis function
- Debugger and simple programmer provided
- Palm size



Ultra-low-priced on-chip emulator N-Wire CARD

- Ultra low price 1/10 the price of conventional emulators
- Connectable to PC via PCMCIA
- Writing to the microcontroller on-chip flash memory possible
- Debugger provided



Starter kit for simple evaluation TK-850 Series

- Evaluation kit enabling easy performance testing
- Lineup for V850ES/Kx1, V850ES/SA2, and V850ES/SG2
- Debugger, compiler, and circuit diagrams provided as standard

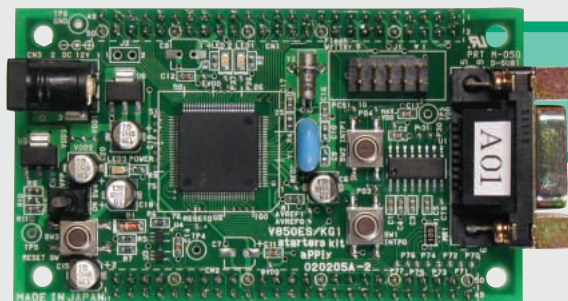

Function

* For details, refer to V850 Series Development Environment Pamphlet (U15763E)

Development Flow

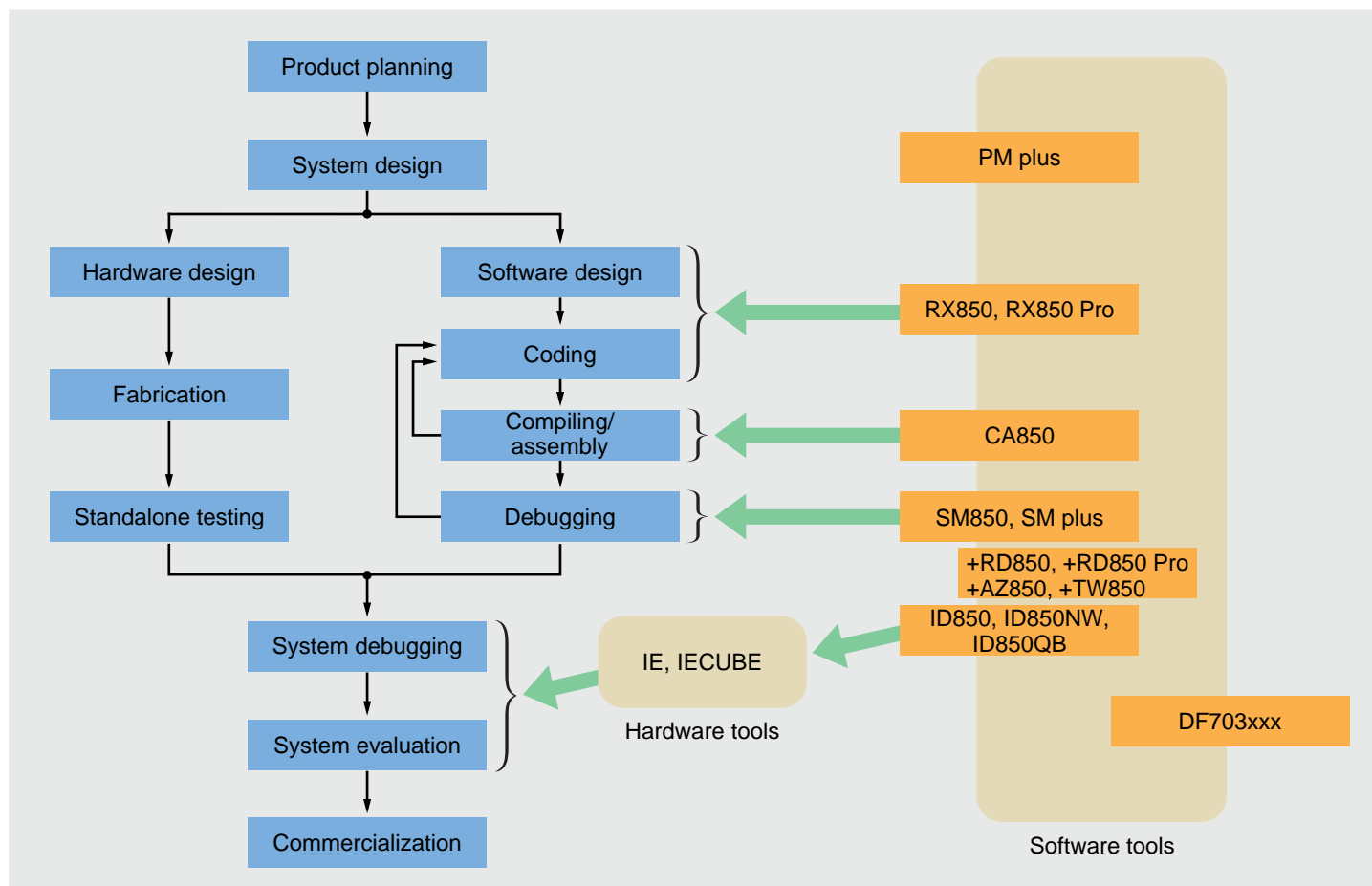

Development Tools (1/3)

Software tools

	Product Name
Software package	SP850
C compiler	CA850 ^{Note 1}
Device file	DF703xxx ^{Note 2}
Project Manager	PM plus ^{Notes 1, 3}
Integrated debugger	ID850 ^{Note 1} , ID850NW ^{Note 1} , ID850QB ^{Note 4}
System simulator	SM850 ^{Note 1} , SM plus ^{Note 5}
Real-time OS	RX850, RX850 Pro
Task debugger	RD850, RD850 Pro ^{Note 6}
System performance analyzer	AZ850 ^{Note 6}
Middleware	AP703000-Bxxx, AP703100-Bxxx
Performance analysis tool	TW850 ^{Note 1}

Notes 1. Packaged in SP850

2. Download from the NEC Electronics Website.
(URL: http://www.necel.com/micro/index_e.html)

3. Included with CA850

4. Included with IECUBE and IE-V850E1-CD-NW.

5. Instruction simulation version: Included with SP850.

Instruction + peripheral simulation version: Only the SM plus for the μ PD70F3261Y is included with SP850.

6. Included with RX850, RX850 Pro

Remark For details, refer to the **V850 Series Development Environment Pamphlet (U15763E)**.

Development Tools (2/3)

Hardware tools (when using IECUBE)

Target Device	In-Circuit Emulator
V850ES/SG2, V850ES/SJ2	QB-V850ESSX2-ZZZ
V850E/IA3, V850E/IA4, V850ES/IK1	QB-V850EIA4-ZZZ
V850ES/KE1, V850ES/KE1+, V850ES/KF1, V850ES/KF1+, V850ES/KG1, V850ES/KG1+, V850ES/KJ1, V850ES/KJ1+	QB-V850ESKX1H-ZZZ
V850ES/FE2, V850ES/FF2, V850ES/FG2, V850ES/FJ2, μ PD703229Y, 70F3229Y	QB-V850ESFX2-ZZZ

- Remarks 1.** A separate socket is required for each above emulator.
2. A power supply, a USB interface cable, a debugger, and a simple programmer are included. A PC interface board is not required.
3. For details, refer to the **V850 Series Development Environment Pamphlet (U15763E)**.

Hardware tools (when using N-Wire CARD)

Target Device	On-Chip Debug Emulator
V850E/ME2, V850E/MA3, V850E/IA4, V850E/SV2, V850ES/SG2, V850ES/SJ2, V850ES/FE2, V850ES/FF2, V850ES/FG2, V850ES/FJ2, V850ES/KJ1, V850ES/KJ1+, μ PD70F3229Y	IE-V850E1-CD-NW

- Remarks 1.** A target connection cable, a connector conversion board, a target connector, and a debugger are included.
 A power supply and a PC interface board are not required.
2. For details, refer to the **V850 Series Development Environment Pamphlet (U15763E)**.

Hardware tools (using other emulators)

Target Device	In-Circuit Emulator	
	Main Unit	Emulation Board
V850ES/SA2, V850ES/SA3	IE-V850ES-G1	IE-703204-G1-EM1 ^{Note 1}
V850ES/KF1, V850ES/KG1, V850ES/KJ1		IE-703217-G1-EM1 ^{Note 2}
V850ES/SG2, V850ES/SJ2		IE-703288-G1-EM1 ^{Note 2}
V850ES/PM1		IE-703228-G1-EM1 ^{Note 2}
V850ES/FE2, V850/FF2, V850ES/FG2, V850ES/FJ2, μ PD703229Y, 70F3229Y		IE-703239-G1-EM1 ^{Note 2}
V850ES/ST2		IE-703220-G1-EM1 ^{Note 2}
V850E/SV2	IE-V850E-MC-A	IE-703166-MC-EM1
V850E/MA1, V850E/MA2	IE-V850E-MC	IE-703107-MC-EM1 ^{Note 3}
V850E/IA1		IE-703116-MC-EM1
V850E/IA2	IE-703102-MC	IE-703114-MC-EM1
V850E/MS1 (5V), V850E/MS2 (5V)		IE-703102-MC-EM1 ^{Note 3}
V850E/MS1 (3.3V)	IE-703002-MC	IE-703102-MC-EM1-A
V850/SA1		IE-703017-MC-EM1 ^{Note 3}
V850/SB1, V850/SB2		IE-703037-MC-EM1 ^{Note 3}
V850/SV1		IE-703040-MC-EM1 ^{Note 3}
V850/SF1		IE-703079-MC-EM1 ^{Note 3}
V850/SC1, V850/SC2, V850/SC3		IE-703089-MC-EM1
V853		IE-703003-MC-EM1

- Notes 1.** A separate socket and probe are required for connection to the target system.
 The optional PC interface board (IE-70000-PCI-IF-A or IE-70000-CD-IF-A) are required as a common part.
2. A separate socket is required for connection to the target system.
 The optional PC interface board (IE-70000-PCI-IF-A or IE-70000-CD-IF-A) are required as a common part.
3. Depending on the target device package, a separate socket and probe may be required.
 The following items are required as common items.
 • PC interface board: IE-70000-PCI-IF-A or IE-70000-CD-IF-A
 • Power supply: IE-70000-MC-PS-B

Remark For details, refer to the **V850 Series Development Environment Pamphlet (U15763E)**.

Development Tools (3/3)

● IECUBE configuration example



- ① In-circuit emulator (IECUBE)
- ② AC adapter (provided with ①)
- ③ USB interface cable (provided with ①)
- ④ Extension probe
- ⑤ Exchange adapter (provided with ① ^{Note})
- ⑥ Target connector (provided with ① ^{Note})
- ⑦ Mount adapter

Note If ordering the in-circuit emulator (①), if the part number ends in "-ZZZ", the above exchange adapter (⑤) and target connector (⑥) are not provided.

● N-Wire CARD configuration example



- ① Host machine (with PCMCIA slot)
- ② On-chip emulator IE-V850E1-CD-NW
- ③ In-circuit emulator connection cable
- ④ Connector conversion board
- ⑤ In-circuit emulator connector

● IE-V850ES-G1 configuration example



- ① In-circuit emulator (main unit)
- ② Emulation board (connected inside main unit)
- ③ Emulation probe
- ④ Conversion adapter/conversion socket
- ⑤ PC interface cable (provided with ①)
- ⑥ Power supply cable (provided with ①)

● IE-V850E-MC, IE-V850E-MC-A, IE-703102-MC, IE-703002-MC configuration example

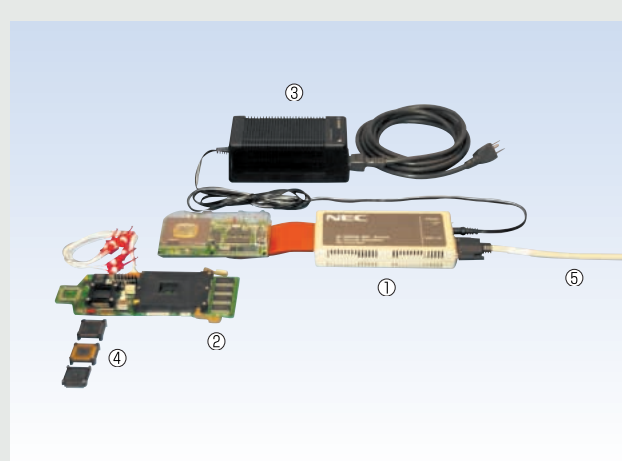

- ① In-circuit emulator (main unit)
- ② Option board
- ③ Power supply unit
- ④ Conversion adapter/conversion socket (provided with ②)
- ⑤ PC interface cable (provided with ①)

V850 Series Development Environment (1/2)

Development environment using in-circuit emulator, N-Wire emulator

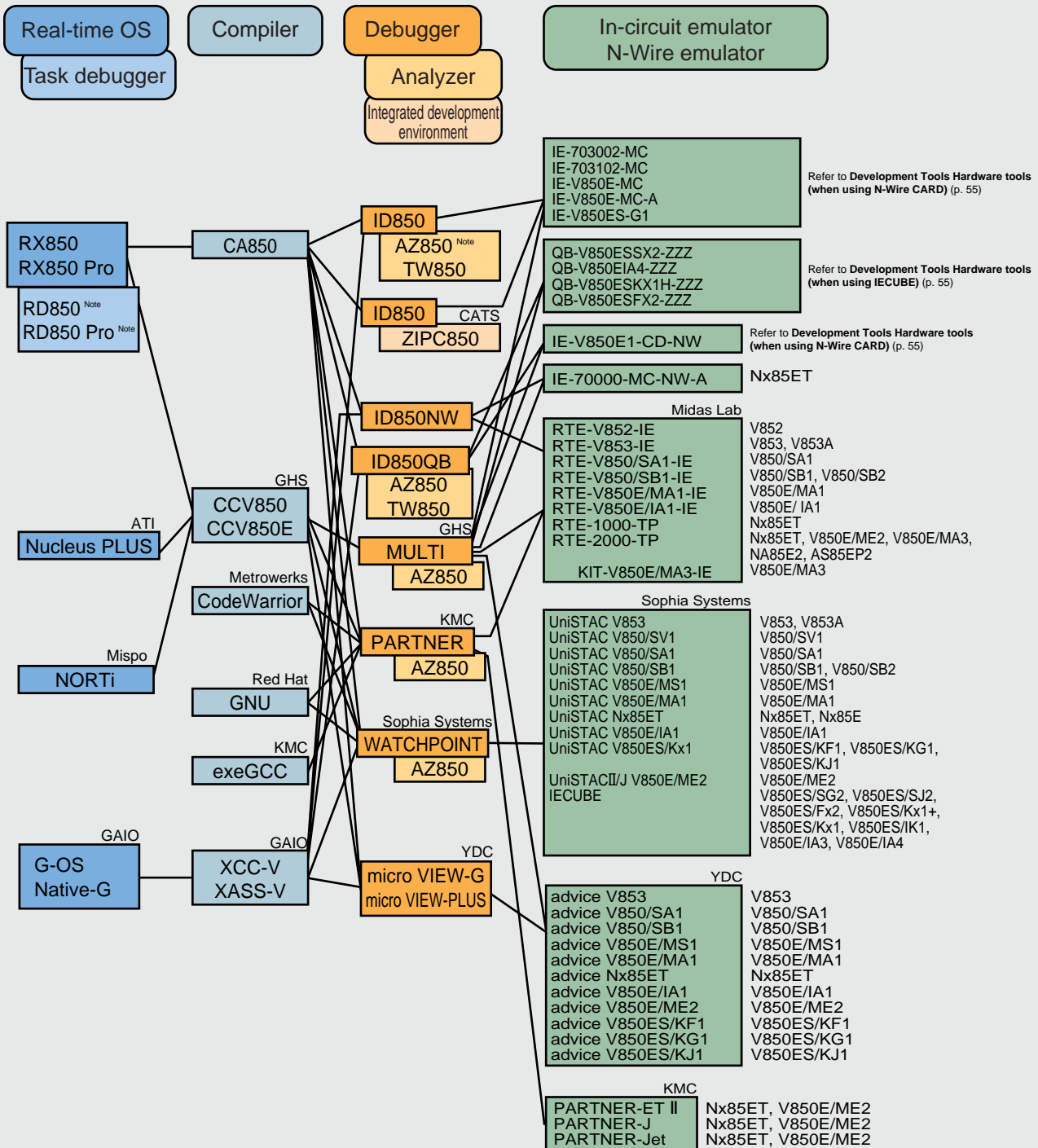

Note The RD850, RD850 Pro, and AZ850 can be used with the ID850, ID850QB, MULTI, PARTNER, and WATCHPOINT.

ATI	:Accelerated Technology, Inc.	Midas Lab	:Midas Lab Co., Ltd.
CATS	:Communication and Technology Systems, Inc.	Mispo	:MiSPO, Inc.
GAIO	:Gaio Technology Co., Ltd.	Red Hat	:Red Hat Corporation
GHS	:Green Hills Software, Inc.	Sophia Systems	:Sophia Systems Co., Ltd.
KMC	:Kyoto Microcomputer Corporation	YDC	:Yokogawa Digital Computer Corporation
Metrowerks	:Metrowerks Corporation	Unmarked	:NEC Electronics

Development Environment

V850 Series Development Environment (2/2)

Development environment using ROM emulator, evaluation board

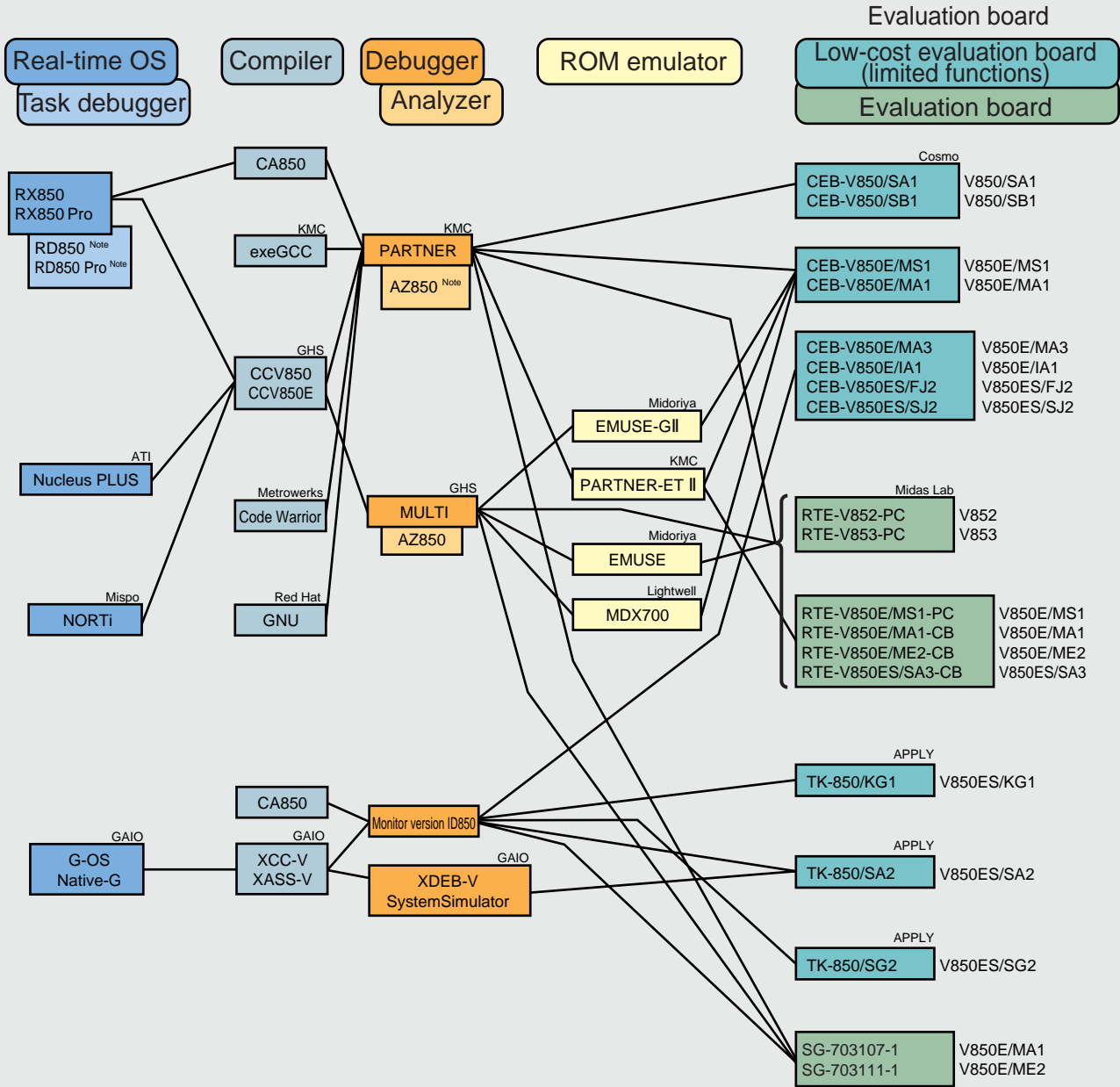

Note RD850, RD850 Pro, and AZ850 can be used with MULTI, PARTNER.

APPLY :Application Corporation
 ATI :Accelerated Technology, Inc.
 Cosmo :Cosmo Co., Ltd.
 Red Hat :Red Hat Corporation
 GAIO :Gaio Technology Co., Ltd.
 GHS :Green Hills Software, Inc.
 KMC :Kyoto Microcomputer Corporation
 Lightwell :Lightwell Co., Ltd.

Metrowerks :Metrowerks Corporation
 Midas Lab :Midas Lab, Co., Ltd.
 Midoriya :Midoriya Electric Co., Ltd.
 Mispo :MiSPO, Inc.
 WRS :Wind River Systems, Inc.
 eSOL :eSOL Co., Ltd.
 Unmarked :NEC Electronics

Software Product

Software package (SP850)

Product configuration

The SP850 software package consists of the following software development tools.

- C compiler (CA850)
- Project Manager (PM plus)
- Integrated debugger (ID850, ID850NW) (to be packaged)
- System simulator (SM850, SM plus) (to be packaged)
- Performance analysis tuning tool (TW850)
- Device file (DF703xxx)

System simulator (SM850, SM plus)

Features

- Same operability as debugger
- Target-less evaluation prior to target completion possible
- In addition to the operation of the CPU itself, target system operation including on-chip peripheral unit and interrupt servicing can also be simulated.
- Pseudo-target system construction and I/O operation are possible through external parts.
- Data generated by 0/1 logic and timing charts can be input to the program being simulated.
- Larger number of events than in-circuit emulator
- Execution speed estimates can be done on the host machine to accurately simulate pipeline operation^{Note}.
- Construction by user target system users is possible through user open interface.
- A peripheral I/O register status can be specified and when this status occurs, the system can be made to output an interrupt at the desired timing or transfer data to memory (peripheral I/O register event & action function).

Note The pipeline mode is supported by the V853.

Target devices

V853, V850/SA1, V850/SB1, V850/SB2, V850/SF1, V850/SC1, V850/SC2, V850/SC3, V850E/MS1, V850E/MA1, V850E/MA2, V850E/IA1, V850E/IA2, V850ES/SA2, V850ES/SA3, V850ES/KF1, V850ES/KG1, V850ES/KJ1, V850ES/SG2^{Note}, V850ES/SJ2^{Note}, V850ES/FE2^{Note}, V850ES/FF2^{Note}, V850ES/FG2^{Note}, V850ES/FJ2^{Note}

Note Only SM plus is supported

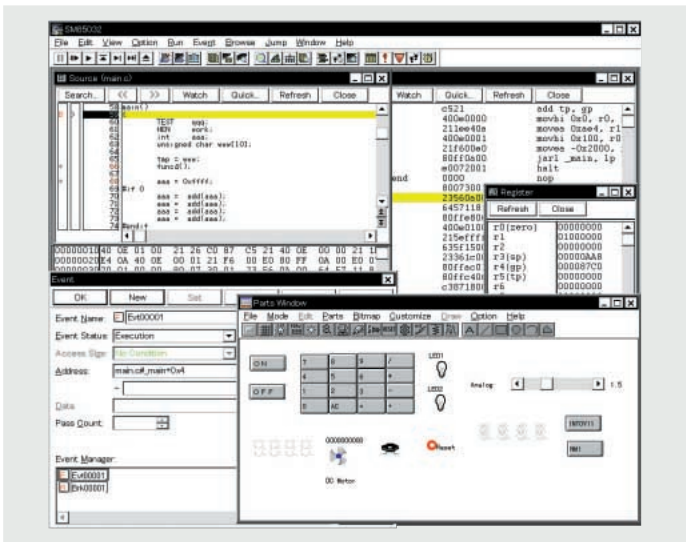

C compiler (CA850)

Features

- Complies with ANSI-C, a C language standard.
- Supports libraries for embedded systems
- Compact code size and faster execution speed can be realized through powerful optimization
- Utilities useful for embedded systems (ROMization processor, etc.)
- Description of embedded systems in C language (specification of memory allocation and I/O register access) is possible.

Project manager (PM plus)

Features

- Project management (management of target chip, source, and environment during debugging is possible.)
- Supports wizard function during project creation
- Automation of series of operations consisting of edit, build, and debug
- Integration of Help function

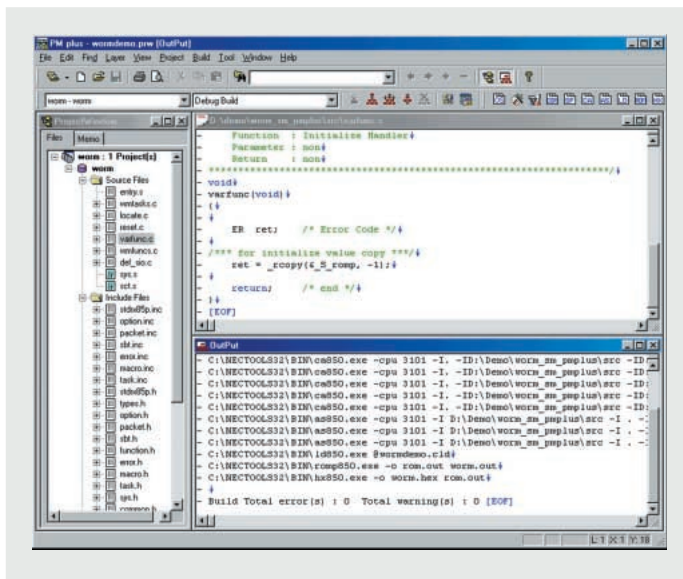

N-Wire card (IE-V850E1-CD-NW)

Features

- Supports V850E and V850ES
- Emulator for on-chip debugging
- Enables realization of low-cost development environment
- Compact PC card type
- Function for download to internal flash ROM
- Same ease of operation as ID850

Target Devices

V850E/ME2, V850E/MA3, V850E/IA4, V850E/SV2, V850ES/SG2, V850ES/SJ2, V850ES/FE2, V850ES/FF2, V850ES/FG2, V850ES/FJ2, V850ES/KJ1, V850ES/KJ1+, μPD70F3229Y

● OSEK/VDX specifications compliant OS (RX-OSEK850)

■ Features

- Kernel
 - Compliant with OSEK/VDX OS Ver. 2.0 specifications
 - Supports 4 conformance classes: BCC1, BCC2, ECC1, and ECC2.
- Configurator
 - Configurator (OIL850) allowing easy system information creation provided as standard.
 - Configuration files support formats compatible with OIL Ver. 2.0.
- Task debugger (RD-OSEK850)
 - Task debugger effective for application debugging using RX-OSEK850 provided as standard

● RISC microcontroller reference platform (SolutionGear™)

■ Features

- General-purpose evaluation boards available as RISC microcontroller software development platform
- Target CPU: V850E/MA1, V850E/ME2
- Industry standard PC-compatible interfaces including PCI, ISA, PCMCIA, E-IDE, Ethernet™, Serial, Parallel, PS/2, and USB, provided
- CPU independent motherboards and CPU boards used combined
- Bundled real-time OS, middleware, and sample drivers
- MULTI-PARTNER remote monitor version can be used
- Reference design information provided

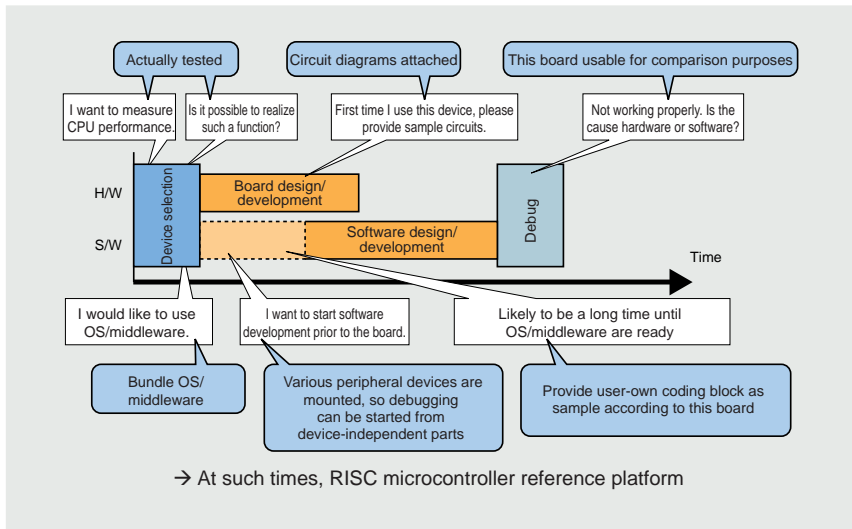

● Cooperation with third parties

By deepening cooperation with third-party companies and forming an array of tools combining NEC Electronics-made tools and third-party-made tools, NEC Electronics offers development environments that support the diverse needs of users.

V850 Series Website

Information about V850 microcontrollers and V850 microcontroller development environment can be viewed at the NEC Electronics Microcomputer website.

http://www.necel.com/micro/index_e.html

Microcontroller Search Tool

- Facility for searching for V850 Series microcontrollers by function

Product Lineup

- Microcontroller product information

Document Download

- Microcontroller, development environment, and middleware documents can be downloaded from this area.

<http://www.necel.com/micro/english/document/index.html>

Development Tool Download

- V850 Series development tools can be downloaded from this area. Customers who are registered users receive upgrade information by email.

<http://www.necel.com/micro/ods/eng/index.html>

The screenshot displays the NEC Electronics Microcomputer website. The top navigation bar includes links for HOME, SOLUTIONS, PRODUCTS, TECH HIGHLIGHTS, SUPPORT, COMPANY PROFILE, and NEWS & EVENTS. A left sidebar menu lists: MICROCOMPUTER SEARCH, Microcomputer HOME, Product Overview, Product Lineup, Development Environment, Design Information, and Documentation. Below this is a 'NEW PRODUCT INFO' section with links for FAQ, Development tools download (ODS), Contact Us, and Site Update. The main content area features a 'Microcomputer' header with a product image and a text block: 'NEC Electronics prepares the 4-64 bit attractive microcomputer-product lineup. And NEC Electronics provides the powerful development environment and the solutions for storing support to your product development.' Below this is a 'FEATURE' section for '8-bit ALL Flash MCUs' listing '78K0/Kx2 Series' and 'LPC(Low Pin Count) Series (78K0S/Kx1+)'. A 'PRESS RELEASE' section lists several announcements from 2004, including the introduction of the 78K0/Kx2 8-bit Microcontroller Series with Flash Memory, the expansion of the 78K0S series, and the introduction of the newest member of the K1 Microcontroller Family. A 'SITE UPDATES' section lists numerous page updates and new product lineups. A right sidebar contains a 'SEARCH' box and a 'RELATED CONTENT' section with links to System Applications, Package Information, Middleware, Quality & Reliability, and Innovation Channel. The footer includes 'Contact Us', 'Site Map', 'Site Policies', and the copyright notice '© 1995-2004 NEC Electronics Corporation'.

Microcontroller Search Tool

Facility for searching V850 Series microcontrollers by function.

Rate of hit	Product Name	Application	Bit count	Series	Sub series(Nickname)	Package Pin count	Development Tools	Document	Functions except search items
1/1	UPD703209	General Purpose	16,32-bit	V850Series	V850ESMF1	GC-SBT 80pin	NEC Electronics Tools	List	ROM Correction
1/1	UPD703208	General Purpose	16,32-bit	V850Series	V850ESMF1	GK-9EU 80pin	NEC Electronics Tools	List	ROM Correction
1/1	UPD703208Y	General Purpose	16,32-bit	V850Series	V850ESMF1	GC-SBT 80pin	NEC Electronics Tools	List	ROM Correction
1/1	UPD703208Y	General Purpose	16,32-bit	V850Series	V850ESMF1	GK-9EU 80pin	NEC Electronics Tools	List	ROM Correction
1/1	UPD703209	General Purpose	16,32-bit	V850Series	V850ESMF1	GC-SBT 80pin	NEC Electronics Tools	List	ROM Correction

Specify search condition(s) here.

The corresponding NEC Electronics development environment documents can be searched from here with a single link.

Development Tool List

Document Information List

UPD703209GC-SBT Development Tools List [Software]

Category	Name	Rev	Notes	Document
Software Package	SP850	V3.00	-	List
Device File	DF703210	V1.00	-	List
C-Compiler	CA703000	V2.50	-	List
Assembler	-	-	-	-
Integrated Debugger	ID703000	V2.51	-	List
Integrated Debugger(N-Wire)	-	-	-	-
System Simulator	-	-	-	-
System Performance Analyzer	AZ703000	V3.10	-	List
Real Time OS	RX703000	V3.13	-	List
	RX703100	V3.13	-	List

[Hardware]

Category	Name	Rev	Notes	Document
Emulator	IE-V850ES-G1	D	-	List
Emulator (Entry Model)	IE-V850ESK1-ET	A	-	List
N-Wire Emulator	-	-	-	-
Emulation(Option) Board	IE-703217-G1-EM1	B(1.20)	-	List
AT Compatible (PCI-Bus)	IE-70000-PCI-IF-A	B	-	-
Note PC (PCMCIA)	IE-70000-CD-IF-A	A	-	-

No.	Product Name	Document No.	Document Categories	Date	Title
1	UPD703209	U15412EJ3V0FP00	Pamphlet	01/2004	V850 Series Pamphlet
2	UPD703209	U15763EJ3V0FP00	Pamphlet	02/2004	V850 Series Development Environment Pamphlet
3	UPD703209	U15943EJ3V0UD00	User's Manual	04/2004	V850ES 32-Bit Microprocessor Core for Architecture
4	UPD703209	U16391EJ3V0FP00	Pamphlet	09/2004	Kst Series Pamphlet
5	UPD703209	U16891EJ1V0UD00	UM Including Electrical Characteristics	06/2004	V850ES/ELF1 for Hardware

Product Lineup

NEC ELECTRONICS > PRINT > **NEC**

HOME SOLUTIONS **PRODUCTS** TECH HIGHLIGHTS SUPPORT COMPANY PROFILE NEWS & EVENTS

MICROCOMPUTER SEARCH MICROCOMPUTER SEARCH >>

Microcomputer HOME

- Product Overview >
- Product Lineup >**
 - 32bit V850 Series**
 - Function List
 - High-end evolution >
 - ASSP evolution >
 - Middle-range evolution >
 - Low-end evolution >
 - About CPU core
 - Packages Lineup
 - Internal Memory Lineup
 - Architecture V850E1 and V850ES >
 - Development Environment >
 - Design Information >
 - Documentation

MORE PRODUCT INFO

- FAQ
- Development tools download (ODS)
- Contact Us
- Site Update

32bit V850 Series

V850E2 Core 200~400MHz Core release of CPU is completed. In the midst of product development plan

V850E1 Core 150MHz @215MIPS

V850 Core 33MHz @38MIPS

V850ES Core 20MHz @29MIPS

High-End evolution
Highly efficient pursuit, MEMC, On-chip DMA
 • Frequency : 33~150MHz
 • Memory ROM : ROM less ~512KB
 • Size RAM : 4~128KB
 • PKG : 100~176-pin (QFP&FBGA)

ASSP evolution
Inverter control
DVC control
Airbag control
Car audio control
Electric power meter control
Car electronics control
 • Frequency : 16~64Hz
 • Memory Size ROM : 64~640KB
 RAM : 4~48KB
 • PKG : 64~257-pin (QFP&FBGA)

Middle-range evolution
Realization of a low EMI noise
 • Frequency : 20~32MHz
 • Memory Size ROM : 64~640KB
 RAM : 4~48KB
 • PKG : 100~144-pin (QFP&FBGA)

Low-end evolution
Pursuit of performance
 • Frequency : 32MHz
 • Memory Size ROM : 64~256KB
 RAM : 4~16KB
 • PKG : 64~144-pin (QFP)

Standard line-up Field correspondence line-up

Instruction set upward compatible

EEPROM, IEBus, IECUBE, SolutionGear, and V_R are trademarks of NEC Electronics Corporation.

MIPS is a trademark of MIPS Technologies, Inc. in the United States.

Windows and Windows NT are either registered trademarks or trademarks of Microsoft Corporation in the United States and/or other countries.

JAVA and all trademarks and logos related to **JAVA** are either registered trademarks or trademarks of Sun Microsystems, Inc. in the United States and/or other countries.

Ethernet is a trademark of Xerox Corporation.

TRON stands for **The Real-time Operating system Nucleus**.

ITRON is an abbreviation of **Industrial TRON**.

μITRON is an abbreviation of **Micro Industrial TRON**.

TRON, ITRON, and μITRON do not refer to specific products or product groups.

All other marks or trademarks in this document are property of their respective holders.

These commodities, technology or software, must be exported in accordance with the export administration regulations of the exporting country. Diversion contrary to the law of that country is prohibited.

• **The information in this document is current as of September, 2004. The information is subject to change without notice. For actual design-in, refer to the latest publications of NEC Electronics data sheets or data books, etc., for the most up-to-date specifications of NEC Electronics products. Not all products and/or types are available in every country. Please check with an NEC Electronics sales representative for availability and additional information.**

• No part of this document may be copied or reproduced in any form or by any means without the prior written consent of NEC Electronics. NEC Electronics assumes no responsibility for any errors that may appear in this document.

• NEC Electronics does not assume any liability for infringement of patents, copyrights or other intellectual property rights of third parties by or arising from the use of NEC Electronics products listed in this document or any other liability arising from the use of such products. No license, express, implied or otherwise, is granted under any patents, copyrights or other intellectual property rights of NEC Electronics or others.

• Descriptions of circuits, software and other related information in this document are provided for illustrative purposes in semiconductor product operation and application examples. The incorporation of these circuits, software and information in the design of a customer's equipment shall be done under the full responsibility of the customer. NEC Electronics assumes no responsibility for any losses incurred by customers or third parties arising from the use of these circuits, software and information.

• While NEC Electronics endeavors to enhance the quality, reliability and safety of NEC Electronics products, customers agree and acknowledge that the possibility of defects thereof cannot be eliminated entirely. To minimize risks of damage to property or injury (including death) to persons arising from defects in NEC Electronics products, customers must incorporate sufficient safety measures in their design, such as redundancy, fire-containment and anti-failure features.

• NEC Electronics products are classified into the following three quality grades: "Standard", "Special" and "Specific".

The "Specific" quality grade applies only to NEC Electronics products developed based on a customer-designated "quality assurance program" for a specific application. The recommended applications of an NEC Electronics product depend on its quality grade, as indicated below. Customers must check the quality grade of each NEC Electronics product before using it in a particular application.

"Standard": Computers, office equipment, communications equipment, test and measurement equipment, audio and visual equipment, home electronic appliances, machine tools, personal electronic equipment and industrial robots.

"Special": Transportation equipment (automobiles, trains, ships, etc.), traffic control systems, anti-disaster systems, anti-crime systems, safety equipment and medical equipment (not specifically designed for life support).

"Specific": Aircraft, aerospace equipment, submersible repeaters, nuclear reactor control systems, life support systems and medical equipment for life support, etc.

The quality grade of NEC Electronics products is "Standard" unless otherwise expressly specified in NEC Electronics data sheets or data books, etc. If customers wish to use NEC Electronics products in applications not intended by NEC Electronics, they must contact an NEC Electronics sales representative in advance to determine NEC Electronics' willingness to support a given application.

(Note)

(1) "NEC Electronics" as used in this statement means NEC Electronics Corporation and also includes its majority-owned subsidiaries.

(2) "NEC Electronics products" means any product developed or manufactured by or for NEC Electronics (as defined above).

*For further information,
please contact:*

NEC Electronics Corporation
1753, Shimonumabe, Nakahara-ku,
Kawasaki, Kanagawa 211-8668,
Japan
Tel: 044-435-5111
<http://www.necel.com/>

[North America]

NEC Electronics America, Inc.
2880 Scott Blvd.
Santa Clara, CA 95050-2554, U.S.A.
Tel: 408-588-6000
800-366-9782
<http://www.necelam.com/>

[Europe]

NEC Electronics (Europe) GmbH
Arcadiastrasse 10
40472 Düsseldorf, Germany
Tel: 0211-65030
<http://www.ee.nec.de/>

Sucursal en España
Juan Esplandiu, 15
28007 Madrid, Spain
Tel: 091-504-2787

Succursale Française
9, rue Paul Dautier, B.P. 52
78142 Velizy-Villacoublay Cédex
France
Tel: 01-3067-5800

Filiale Italiana
Via Fabio Filzi, 25/A
20124 Milano, Italy
Tel: 02-667541

Branch The Netherlands
Boschdijk 187a
5612 HB Eindhoven
The Netherlands
Tel: 040-2445845

Tyskland Filial
P.O. Box 134
18322 Taeby, Sweden
Tel: 08-6380820

United Kingdom Branch
Cygnus House, Sunrise Parkway
Linford Wood, Milton Keynes
MK14 6NP, U.K.
Tel: 01908-691-133

[Asia & Oceania]

NEC Electronics Hong Kong Ltd.
12/F., Cityplaza 4,
12 Taikoo Wan Road, Hong Kong
Tel: 2886-9318

Seoul Branch

11F., Samik Lavied'or Bldg., 720-2,
Yeoksam-Dong, Kangnam-Ku,
Seoul, 135-080, Korea
Tel: 02-558-3737

NEC Electronics Shanghai Ltd.
Room 2509-2510, Bank of China Tower,
200 Yincheng Road Central,
Pudong New Area, Shanghai P.R. China P.C:200120
Tel: 021-5888-5400

NEC Electronics Taiwan Ltd.
7F, No. 363 Fu Shing North Road
Taipei, Taiwan, R. O. C.
Tel: 02-2719-2377

NEC Electronics Singapore Pte. Ltd.
238A Thomson Road,
#12-08 Novena Square,
Singapore 307684
Tel: 6253-8311

This datasheet has been download from:

www.datasheetcatalog.com

Datasheets for electronics components.