

# Swifts® SRF heavy duty return flange straight lengths

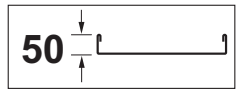

## ■ Dimensions and weights

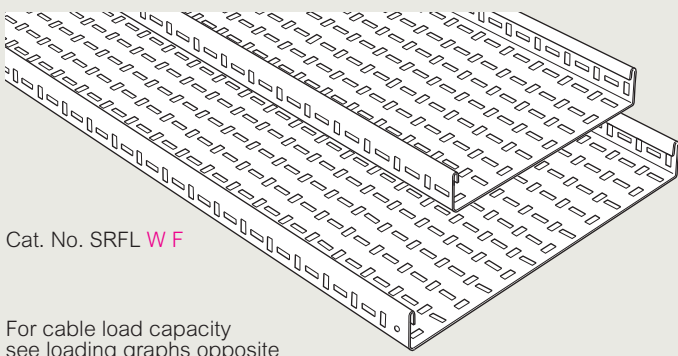

Cat. No. SRFL **WF**

For cable load capacity see loading graphs opposite

## ■ Dimensions

Standard length 3 m

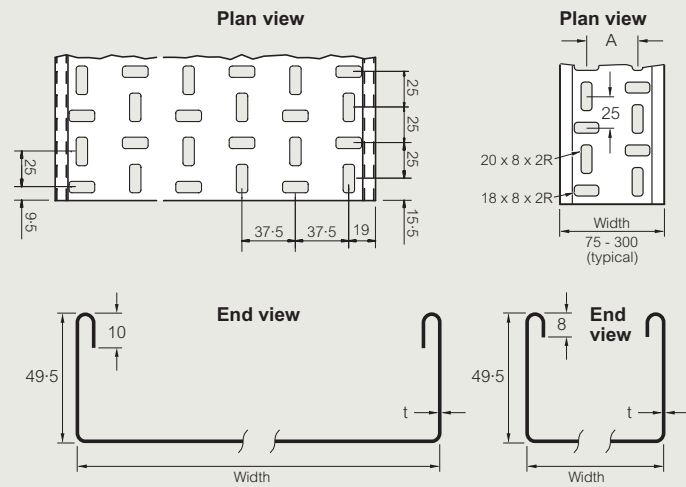

Width (mm)	A (mm)
75	37.50
100	31.75
150 to 900	37.50

R = radius

## ■ Gauges and weights

The gauge 't' for each cable tray width and finish can vary by product and range

Non-standard gauges and finishes are available to special order, contact us on +44 (0) 845 605 4333

Cat. Nos.	Width (mm)	Weight (kg)	Gauge t (mm) G	PG
SRFL 75 <b>F</b>	75	4.2	0.9	0.9
SRFL 100 <b>F</b>	100	4.4	0.9	0.9
SRFL 150 <b>F</b>	150	6.0	0.9	0.9
SRFL 225 <b>F</b>	225	8.9	1.2	1.2
SRFL 300 <b>F</b>	300	10.8	1.2	1.2
SRFL 450 <b>F</b>	450	17.8	1.2	1.2
SRFL 600 <b>F</b>	600	22.9	1.5	1.4
SRFL 750 <b>F</b>	750	35.9	2.0	2.0
SRFL 900 <b>F</b>	900	42.0	2.0	2.0

All weights given are in kilograms (kg) and are for a 3m straight length in hot dip galvanised G finish

To obtain the appropriate component weight in other finishes, multiply the given weight by the following factors :

- Deep galvanised (D) x 1.06
- Stainless steel (S) x 0.94
- Pre-galvanised (PG) x 0.96
- Powder coated (E) x 0.97

## ■ Loading graphs

Load tests carried out to BS EN 61537

The loads shown on all graphs are the safe recommended maximum loads that can be applied and must include wind, snow and any other external forces in addition to the cable load

The graphs show the maximum load for tray installed at a support spacing within its recommended range

When the graph line is above the intersection of the required load and span lines, the support equipment is suitable for use within those load and span conditions

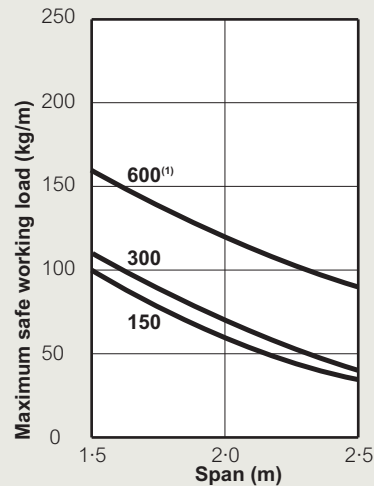

(1) SRFL 600 – tested with fishplates

For lengths 450 mm wide and greater, the addition of fishplate Cat. No. WF **F** across the underside of the length-to-length joint provides added strength and increases the safe working load, see p. 101

## ■ Finishes and standards

### Standard stocked finish :

- G** Hot dip galvanised after manufacture to BS EN ISO 1461
- PG** Pre-galvanised steel to BS EN 10346 : 2009 grade DX51D

### Additional finishes :

- D** Deep galvanised high silicon steel made from BS EN 10025-5 : 2004 Grade S355JOWP
- S** Stainless steel to BS EN 10088 – 2 grade 1-4404 (equivalent to 316L31)
- E** Powder coated (to customer's specification)

**Sheared steel (particularly stainless steel) does have relatively sharp edges and protective gloves must be worn during handling**

All dimensions (mm) are nominal

Key : Replace the letter shown in red with your choice from the following options :

**F** = Finish : **G** (hot dip galvanised after manufacture), **D** (deep galvanised), **PG** (pre-galvanised steel), **S** (stainless steel), **E** (powder coated)

➔ Coupler sets : see p. 63-64

➔ Fishplates : see p. 101

# Swifts® cable tray couplers and fasteners

## SRF straight length to straight length couplers

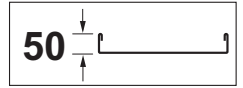

### Standard couplers

Couplers are required for joining together SRF straight lengths or cut lengths of tray without the need for further drilling  
SRFC standard couplers are supplied in pairs  
Supplied without fasteners – use M6 nuts, bolts and washers (see opposite)

As an alternative coupling method, use quick bolt couplers (Cat. No. SRQBCF), which are supplied with quick bolt fasteners (Cat. No. QBF) and a tool, see p. 48

### Installation (typical)

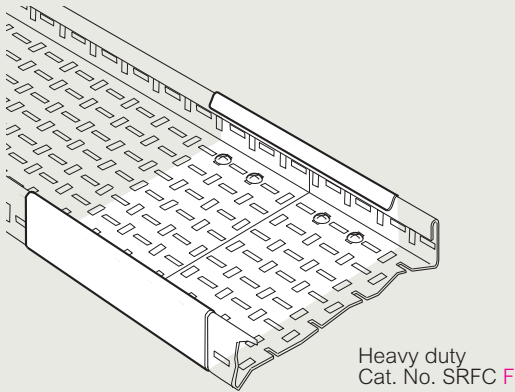

Cat. No.	Tray range
SRFC F	SRF

### Assembly

Bring together two lengths and fit a coupler on the outside of adjacent flanges at both sides of the tray joint  
Locate the coupler as shown and insert two roofing bolts through aligning slots in each tray bed and coupler (four bolts per coupler), and secure with roofing washers and nuts

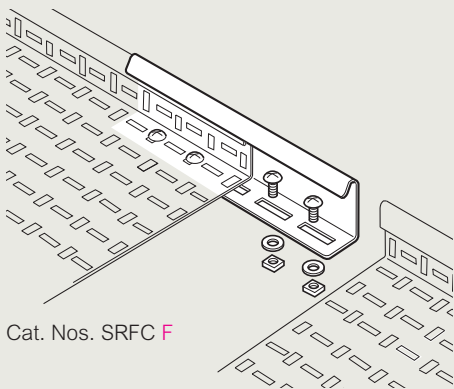

### Assembly (continued)

#### Fasteners

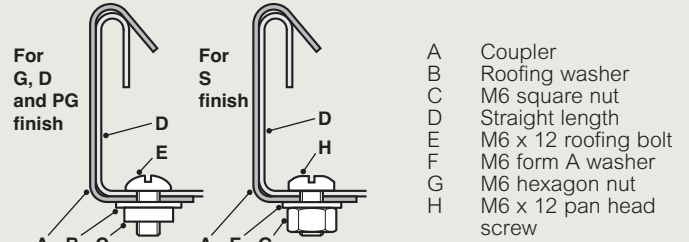

#### Fastener finishes

For lengths and fittings with G, D and PG finishes fasteners are galvanised or zinc plated. For trays and fittings with S finish, fasteners are corrosion resistant stainless Grade A470  
For lengths and fittings with E finish the choice of material for fasteners will depend on the installation environment – contact us on +44 (0) 845 605 4333

#### Note

For quick bolt couplers and fasteners, see p. 48

### Dimensions and weights

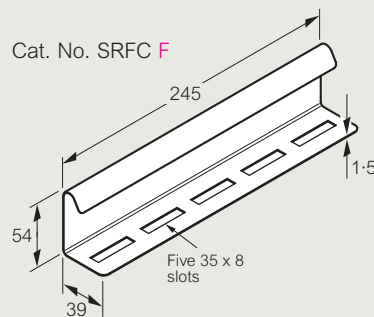

Cat. Nos.	Weight (kg)
SRFC F	0.7 pair

#### Weights

All weights given are in kilograms (kg) and are for hot dip galvanised G finish

To obtain the appropriate component weight in other finishes, multiply the given weight by the following factors :

Deep galvanised	(D) x 1.06
Stainless steel	(S) x 0.94
Pre-galvanised	(PG) x 0.96
Powder coated	(E) x 0.97

All dimensions (mm) are nominal

Key : Replace the letter shown in red with your choice from the following options :

**F** = Finish : **G** (hot dip galvanised after manufacture),  
**D** (deep galvanised), **PG** (pre-galvanised steel),  
**S** (stainless steel), **E** (powder coated)

# Swifts® cable tray couplers and fasteners

## SRF straight length to straight length couplers (continued) and straight length to fitting coupling

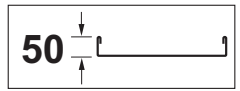

### Quick bolt couplers

Quick bolt couplers are a stronger, faster, easier and safer method of joining together SRF straight lengths or cut lengths of tray without the need for further drilling

Square-shafted quick bolts lock firmly into position before fixing. The nuts, which have integral washers and a serrated edge to reduce slip and improve earthing, can then be easily tightened using a power tool. Supplied in packs containing 25 pairs of couplers, 100 quick bolt fasteners (Cat. No. QBF) and a FREE power tool attachment. For tray widths 300 mm and above use two additional quick bolt fixings (Cat. No. QBF) per coupler.

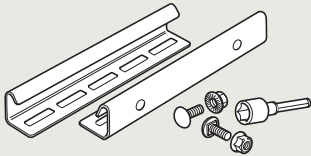

### Installation

Typical installation as per standard couplers, replacing nuts, bolts and washers with quick bolt fasteners, Cat. No. QBF.

### Assembly

Bring together two lengths and fit a coupler on the outside of adjacent flanges at both sides of the tray joint.

Locate the coupler and insert coach bolts through aligning slots in each tray bed and coupler as shown and secure with nuts.

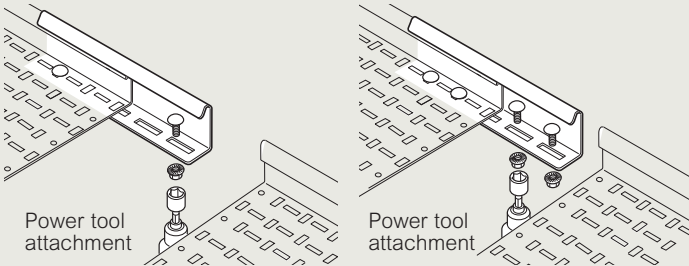

Tray widths up to 225 mm  
Two quick bolt fasteners per coupler

Tray widths 300 mm and above  
Four quick bolt fasteners per coupler

Illustration : MRF shown, SRF similar

### Quick bolt couplers

Cat. Nos.	Tray range	Weight (kg)
SRQBC F	SRF	0.7 pair

### Fasteners

#### Quick bolt fasteners

High grade steel with Dacromet finish

Cat. Nos.	Pack	Size (mm)
QBF	100	M6 x 12

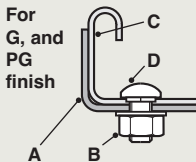

- A Coupler
- B M6 flange nut
- C Straight length
- D M6 coach bolt

### Dimensions and weights

#### Dimensions

For coupler dimensions see p. 63

#### Weights

All weights given are in kilograms (kg) and are for hot dip galvanised G finish.

To obtain the appropriate component weight in other finishes, multiply the given weight by the following factors :

Pre-galvanised (PG) x 0.96

All dimensions (mm) are nominal

→ Straight lengths : see p. 46

### Straight length to fitting coupling

Cable tray fittings must be properly supported. The ideal location for supports is shown in step 2, i.e. 150 mm from the fitting to length joint. For further details see Design Notes, Recommended Support Locations, see p. 128.

#### 1

Where necessary re-align the fitting flange tabs from their transit position to their installation position.

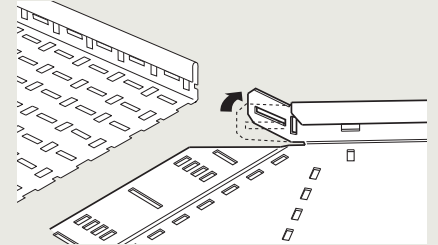

#### 2

When a straight length of cable tray has to be cut back to accept a fitting, always fit the uncut end to the adjacent straight length; the cut end should be connected to the fitting.

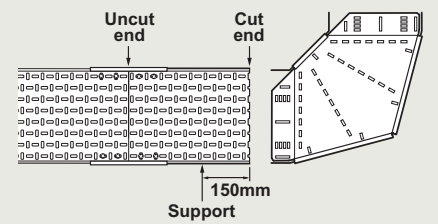

#### 3

Offer the fitting at an angle to the straight length and locate, ensuring that the joggled fishplate fits under the tray bed and the flange tabs slide inside the length flanges.

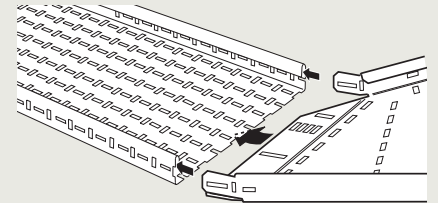

#### 4

Insert roofing bolts or QBF through slots in the tray bed in to aligning slots in the fitting fishplate and secure with roofing washers and nuts. For extra rigidity on SRF fittings, bolts can be fitted through the sides of the lengths and the fitting tabs.

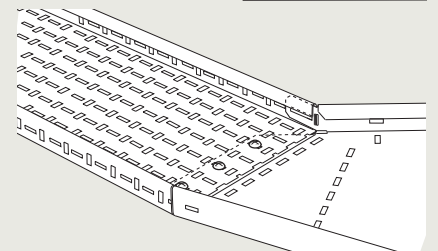

### Note

Fasteners stated are for D, G and PG finishes.

For lengths and fittings with S finish use fasteners listed below.

### Fasteners

Minimum number of fasteners per joint (not included) :

Widths up to 225 = 2

Widths 300 to 600 = 3

Widths 750 and 900 = 4

### Roofing bolts

For G, D and PG finish

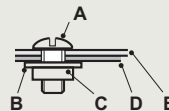

For S finish

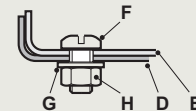

- A M6 x 12 roofing bolt
- B Roofing washer
- C M6 square nut
- D Fitting
- E Straight length
- F M6 x 12 pan head screw
- G M6 form A washer
- H M6 hexagon nut

### Quick bolt fasteners

For G, and PG finish



- A Coupler
- B M6 flange nut
- C Straight length
- D M6 coach bolt

### Fastener finish

For lengths and fittings with G, D and PG finishes, fasteners are galvanised or zinc plated. For trays and fittings with S finish, fasteners are corrosion resistant stainless Grade A470.

For lengths and fittings with E finish, the choice of material for fasteners will depend on the installation environment - contact us on +44 (0) 845 605 4333

# Swifts® SRF heavy duty fittings

## universal bracket and fishplate

### ■ Universal bracket

The universal bracket can be easily folded at one or more of the 9 predetermined points. By overfolding a couple of times, the bracket can be split, for example on the centre line to make a hinged coupler or in between the outer flanges if the length of the bracket needs to be reduced

The square hole is provided to locate the shoulder of the quick bolt fastener – this side should be facing inwards towards the tray to avoid snagging cables

The pitch between each fold point is designed to match up with the Swifts range of SRF cable tray systems

By using different configurations the bracket can be folded to create numerous functions on-site, examples of which are shown below

Cat. No. SRFUB F

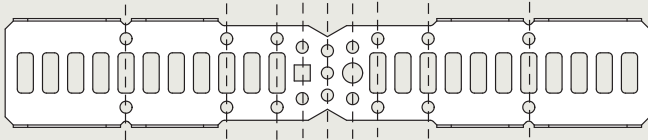

### ■ Installation (typical)

Side dropout

Tee

Bend

Riser

Flange assembly

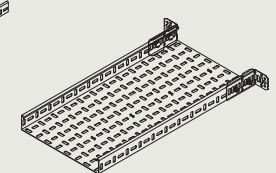
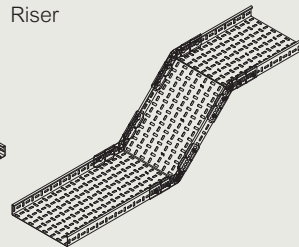
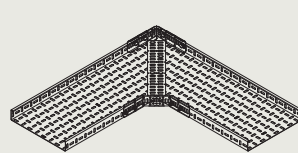
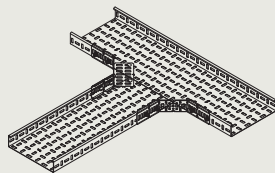
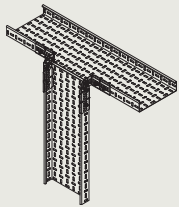

### ■ Dimensions

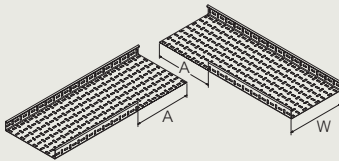

Above dimensions are for 90° bend with overlap joint

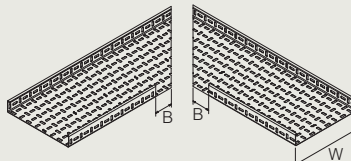

Above dimensions are for 90° bend with diagonal joint. Diagonal cuts are 45°

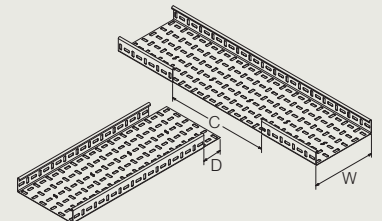

Note 1 : Dimensions are for tee with fishplate joint  
Note 2 : For overlap joint tee use 'D' + 50

Cat. Nos.	Width (W)	Overlap A	Diagonal B	Tee	
				C	D
SRFL 75 F	75	80	85	220	75
SRFL 100 F	100	105	85	245	75
SRFL 150 F	150	155	85	295	75
SRFL 225 F	225	230	85	370	75
SRFL 300 F	300	305	85	445	75

### ■ Handed and straight reducer configurations

Figures show approximated reduced width

Left or right handed reducers are not currently available as a standard factory fabricated fitting

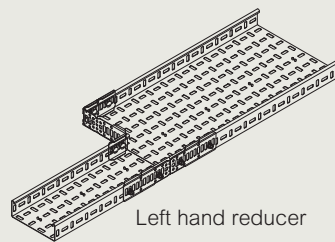

Left hand reducer

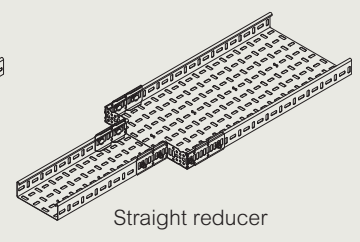

Straight reducer

		SRFL															
Smaller Size		75 mm		100 mm		150 mm		225 mm		300 mm		450 mm		600 mm		750 mm	
Larger Size		Handed	Straight	Handed	Straight	Handed	Straight	Handed	Straight	Handed	Straight	Handed	Straight	Handed	Straight	Handed	Straight
100 mm		25	12	–	–	–	–	–	–	–	–	–	–	–	–	–	–
150 mm		75	37	50	25	–	–	–	–	–	–	–	–	–	–	–	–
225 mm		150	75	125	62	75	37	–	–	–	–	–	–	–	–	–	–
300 mm		–	112	200	100	150	75	75	37	–	–	–	–	–	–	–	–
450 mm		–	–	–	175	–	150	–	112	150	75	–	–	–	–	–	–
600 mm		–	–	–	–	–	–	–	187	–	150	150	75	–	–	–	–
750 mm		–	–	–	–	–	–	–	–	–	–	150	150	75	–	–	–
900 mm		–	–	–	–	–	–	–	–	–	–	–	–	150	150	75	–

All dimensions (mm) are nominal

# Swifts® SRF heavy duty fittings

flat bends – 90°, 60°, 45° and 30°

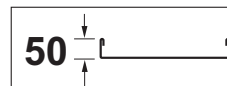

## ■ 90° flat bends – dimensions and weights

Cat. No. SRFB **W F**

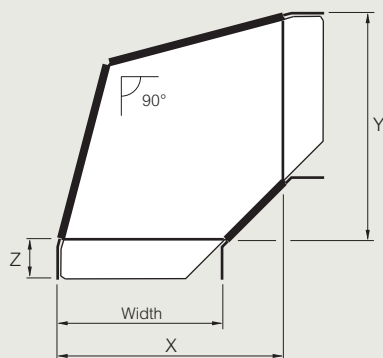

Cat. Nos.	Width	X	Y	Z	Weight (kg)
<b>SRFB 75 F</b>	75	197	197	55	0.6
<b>SRFB 100 F</b>	100	221	221	55	0.8
<b>SRFB 150 F</b>	150	272	272	55	1.0
<b>SRFB 225 F</b>	225	345	345	55	1.5
<b>SRFB 300 F</b>	300	420	420	55	2.6
<b>SRFB 450 F</b>	450	568	568	55	4.3
<b>SRFB 600 F</b>	600	718	718	55	6.4
<b>SRFB 750 F</b>	750	860	860	55	12.4
<b>SRFB 900 F</b>	900	1018	1018	55	16.6

Also consider the versatile adjustable bend for widths 75 mm - 300 mm, see p. 68-69

## ■ 60° flat bends – dimensions and weights

Cat. No. SRFB **W 60 F**

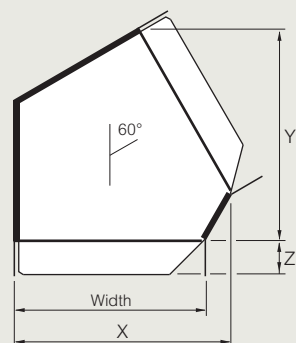

Cat. Nos.	Width	X	Y	Z	Weight (kg)
<b>SRFB 75 60 F</b>	75	133	169	55	0.6
<b>SRFB 100 60 F</b>	100	158	191	55	0.6
<b>SRFB 150 60 F</b>	150	208	234	55	0.8
<b>SRFB 225 60 F</b>	225	283	299	55	1.2
<b>SRFB 300 60 F</b>	300	358	364	55	2.0
<b>SRFB 450 60 F</b>	450	508	493	55	3.4
<b>SRFB 600 60 F</b>	600	658	623	55	5.2
<b>SRFB 750 60 F</b>	750	808	753	55	9.4
<b>SRFB 900 60 F</b>	900	958	882	55	12.5

Also consider the versatile adjustable bend for widths 75 mm - 300 mm, see p. 68-69

Key : Replace the letter shown in red with your choice from the following options :

- F** = Finish : **G** (hot dip galvanised after manufacture), **D** (deep galvanised), **PG** (pre-galvanised steel), **S** (stainless steel), **E** (powder coated)

## ■ 45° flat bends – dimensions and weights

Cat. No. SRFB **W 45 F**

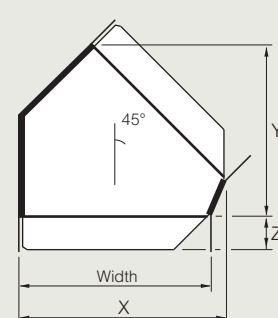

Cat. Nos.	Width	X	Y	Z	Weight (kg)
<b>SRFB 75 45 F</b>	75	108	138	55	0.4
<b>SRFB 100 45 F</b>	100	133	156	55	0.4
<b>SRFB 150 45 F</b>	150	183	191	55	0.6
<b>SRFB 225 45 F</b>	225	258	244	55	0.9
<b>SRFB 300 45 F</b>	300	333	297	55	1.5
<b>SRFB 450 45 F</b>	450	482	402	55	2.5
<b>SRFB 600 45 F</b>	600	632	508	55	3.9
<b>SRFB 750 45 F</b>	750	782	614	55	7.0
<b>SRFB 900 45 F</b>	900	932	720	55	9.4

Also consider the versatile adjustable bend for widths 75 mm - 300 mm, see p. 68-69

## ■ 30° flat bends – dimensions and weights

Cat. No. SRFB **W 30 F**

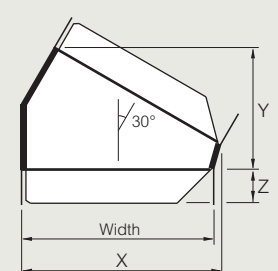

Cat. Nos.	Width	X	Y	Z	Weight (kg)
<b>SRFB 75 30 F</b>	75	88	98	55	0.3
<b>SRFB 100 30 F</b>	100	113	110	55	0.3
<b>SRFB 150 30 F</b>	150	163	135	55	0.4
<b>SRFB 225 30 F</b>	225	238	173	55	0.6
<b>SRFB 300 30 F</b>	300	313	210	55	1.1
<b>SRFB 450 30 F</b>	450	463	285	55	1.8
<b>SRFB 600 30 F</b>	600	613	360	55	2.7
<b>SRFB 750 30 F</b>	750	763	435	55	5.0
<b>SRFB 900 30 F</b>	900	913	510	55	6.6

Also consider the versatile adjustable bend for widths 75 mm - 300 mm, see p. 68-69

All dimensions (mm) are nominal

→ SRF adjustable bends : see p. 68-69

# Swifts® SRF heavy duty fittings

## flat bends – 90°, 60°, 45° and 30° (continued)

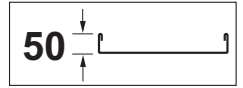

### ■ Dimensions and weights – flat bends 90°, 60°, 45° and 30°

#### Dimensions

X = Length of fitting from each end (excluding integral coupler)

Y = Length of fitting from each end (excluding integral coupler)

Z = End extension of integral coupler

#### Weights

All weights given are in kilograms (kg) and are for hot dip galvanised G finish

To obtain the appropriate component weight in other finishes, multiply the given weight by the following factors :

Deep galvanised (D) x 1.06

Stainless steel (S) x 0.94

Pre-galvanised (PG) x 0.96

Powder coated (E) x 0.97

### ■ Assembly – flat bends 90°, 60°, 45° and 30°

#### Coupling detail – 90°

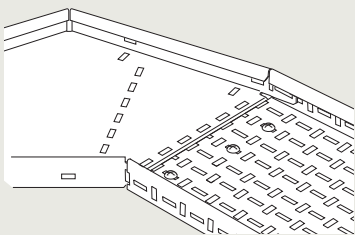

#### Coupling detail – 60°, 45° and 30°

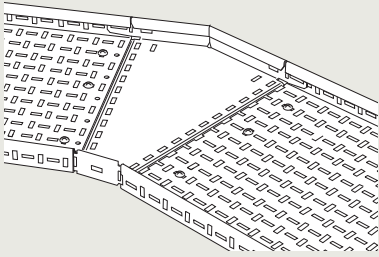

#### Flat bend to straight length coupling

Flat bends have integral couplers which fit into straight lengths whether they have been cut to length or not, without the need for further drilling

Each flat bend to length joint is secured with M6 x 12 bolts (roofing or pan head), nuts and washers or quick bolt fasteners (Cat. No. QBF) see p. 64. Fasteners are not included

Minimum number of fasteners per joint :

Widths up to 225 = 2

Widths 300 to 600 = 3

Widths 750 and 900 = 4

#### Fastener finishes

For flat bends with G, D and PG finishes, fasteners are galvanised or zinc plated. For flat bends with S finish, fasteners are stainless steel

For flat bends with E finish, the choice of material for fasteners will depend on the installation environment. For further information, contact us on +44 (0) 845 605 4333

### ■ Assembly – flat bends 90°, 60°, 45° and 30° (continued)

#### Minimum bend radius for cables – flat bends 90°

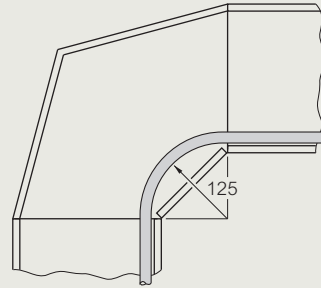

Minimum cable radius = 125 mm

#### Minimum bend radius for cables – flat bends 60°, 45° and 30°

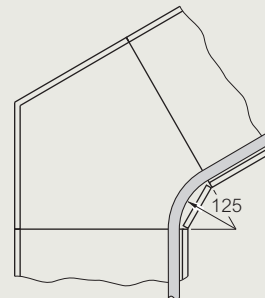

Minimum cable radius = 125 mm

Key : Replace the letter shown in red with your choice from the following options :

**F** = Finish : **G** (hot dip galvanised after manufacture),  
**D** (deep galvanised), **PG** (pre-galvanised steel),  
**S** (stainless steel), **E** (powder coated)

All dimensions (mm) are nominal

→ SRF adjustable bends : see p. 68–69

# Swifts® SRF heavy duty fittings

adjustable flat bends – 75 to 300 mm wide

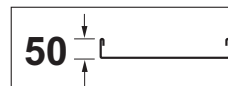

## ■ Dimensions and weights

Cat. No. SRFAB **W F**

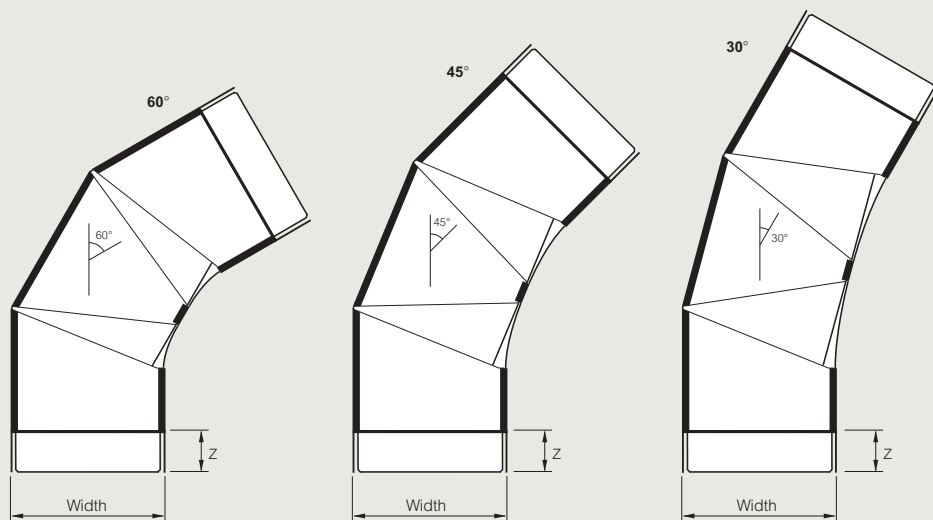

Cat. Nos.	Width	Z	Weight (kg)
<b>SRFAB 75 F</b>	75	55	0.6
<b>SRFAB 100 F</b>	100	55	0.8
<b>SRFAB 150 F</b>	150	55	1.2
<b>SRFAB 225 F</b>	225	55	2.1
<b>SRFAB 300 F</b>	300	55	4.1

For widths 450-900 mm use 60°, 45° and 30° flat bends, see p. 66-67  
 For widths 300 mm and below use adjustable flat bends for all angles up to 90°. Fixed angled flat bends are also available, see p. 66-67

### Dimensions

Z = End extension of integral coupler

### Weights

All weights given are in kilograms (kg) and are for hot dip galvanised G finish

To obtain the appropriate component weight in other finishes, multiply the given weight by the following factors :

- Deep galvanised (D) x 1.06
- Stainless steel (S) x 0.94
- Pre-galvanised (PG) x 0.96
- Powder coated (E) x 0.97

Key : Replace the letter shown in red with your choice from the following options :

- F** = Finish : **G** (hot dip galvanised after manufacture), **D** (deep galvanised), **PG** (pre-galvanised steel), **S** (stainless steel), **E** (powder coated)

All dimensions (mm) are nominal

**SRF flat bends : see p. 66-67**

# Swifts® SRF heavy duty fittings

## adjustable flat bends – 75 to 300 mm wide (continued)

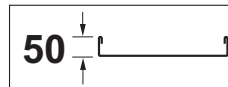

### ■ Assembly

#### Adjusting bend to any angle between 30° and 90°

Adjustable flat bends can be adjusted to any angle between 30° and 90°, refer to the diagram opposite

Insert fasteners through both slots X in the outer sections of the bed and the associated slots Z in the centre section of the bed. Adjust the bendable sections equally until the required angle is formed

Fasteners can also be inserted through the inner flanges when the slots in the fixed outer section flange and the bendable centre section flange align

#### Setting bend to specific angles

Adjustable flat bends can be set to specific fixed angles or they can be adjusted to any angle between 30° and 90° in increments of 7.5°

#### Note

When setting the adjustable flat bend to the required angle, ensure that the bendable inner flanges on the centre section engage in the return flanges on the outer sections

Angle (°)	Fastener holes
30	A + A
37.5	A + B
45	B + B
52.5	B + C
60	C + C
67.5	C + D
75	D + D
82.5	D + E
90	E + E

Refer to the table and the diagram below  
 Insert fastenings through both slots X in the outer sections of the bend and the appropriate holes (A to E) in the centre section of the bed (2 off M6 fastenings included)  
 Fasteners can also be inserted through the inner flanges when the slots in the fixed outer section flange and the bendable centre section flange align

### ■ Assembly (continued)

#### Minimum bend radius for cables

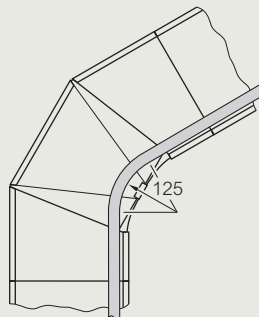

For details on how to set adjustable flat bends to angles, see opposite

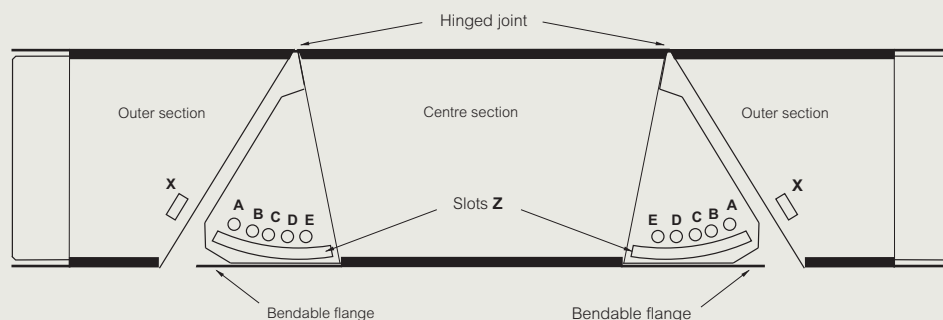

### Coupling detail

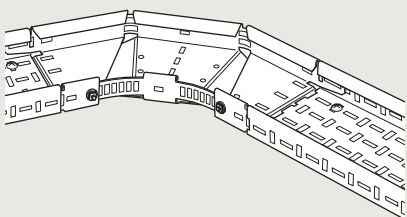

#### Adjustable flat bend to straight length coupling

Flat bends have integral couplers which fit into straight lengths whether they have been cut to length or not, without the need for further drilling  
 Each flat bend to length joint is secured with M6 x 12 bolts (roofing or pan head), nuts and washers or quick bolt fasteners (Cat. No. QBF), see p. 64. Fasteners are not included

Minimum number of fasteners per joint :

Widths up to 225 = 2

Width 300 = 3

#### Fastener finishes

For adjustable flat bends with G, D and PG finishes, fasteners are galvanised or zinc plated

For adjustable flat bends with S finish, fasteners are stainless steel

For adjustable flat bends with E finish, the choice of material for fasteners will depend on the installation environment. For further information, contact us on +44 (0) 845 605 4333

All dimensions (mm) are nominal

Key : Replace the letter shown in red with your choice from the following options :

F = Finish : **G** (hot dip galvanised after manufacture),  
**D** (deep galvanised), **PG** (pre-galvanised steel),  
**S** (stainless steel), **E** (powder coated)

→ SRF flat bends : see p. 66-67

# Swifts® SRF heavy duty fittings

inside and outside risers – 90°, 60°, 45° and 30°

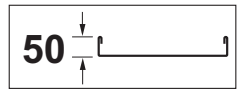

## 90° inside and outside risers – dimensions and weights

### Dimensions

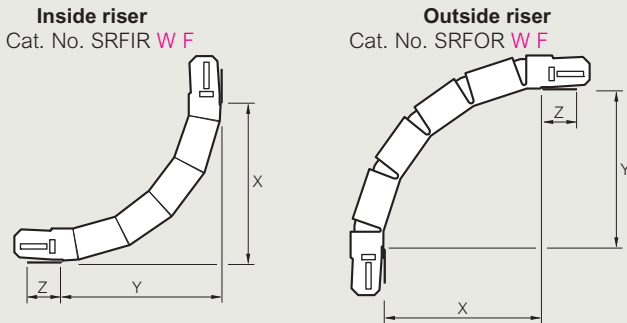

Cat. Nos.	Width	X	Y	Z	Weight (kg)
SRFIR 75 <b>F</b>	75	260	260	55	0.8
SRFIR 100 <b>F</b>	100	260	260	55	0.9
SRFIR 150 <b>F</b>	150	260	260	55	1.2
SRFIR 225 <b>F</b>	225	260	260	55	1.5
SRFIR 300 <b>F</b>	300	260	260	55	2.4
SRFIR 450 <b>F</b>	450	260	260	55	3.4
SRFIR 600 <b>F</b>	600	260	260	55	4.1
SRFIR 750 <b>F</b>	750	260	260	55	6.9
SRFIR 900 <b>F</b>	900	260	260	55	8.2

Cat. Nos. given in the table are for inside risers. For outside risers substitute SRFIR for SRFOR. All fixed risers radius = 260 mm

## 60° inside and outside risers – dimensions and weights

Cat. Nos.	Width	X	Y	Z	Weight (kg)
SRFIR 75 60 <b>F</b>	75	269	155	55	0.7
SRFIR 100 60 <b>F</b>	100	269	155	55	0.8
SRFIR 150 60 <b>F</b>	150	269	155	55	0.9
SRFIR 225 60 <b>F</b>	225	269	155	55	1.3
SRFIR 300 60 <b>F</b>	300	269	155	55	1.9
SRFIR 450 60 <b>F</b>	450	269	155	55	2.5
SRFIR 600 60 <b>F</b>	600	269	155	55	3.2
SRFIR 750 60 <b>F</b>	750	269	155	55	3.7
SRFIR 900 60 <b>F</b>	900	269	155	55	5.8

Cat. Nos. given in the table are for inside risers. For outside risers substitute SRFIR for SRFOR. All fixed risers radius = 260 mm

## 45° inside and outside risers – dimensions and weights

Cat. Nos.	Width	X	Y	Z	Weight (kg)
SRFIR 75 45 <b>F</b>	75	220	91	55	0.5
SRFIR 100 45 <b>F</b>	100	220	91	55	0.6
SRFIR 150 45 <b>F</b>	150	220	91	55	0.8
SRFIR 225 45 <b>F</b>	225	220	91	55	1.0
SRFIR 300 45 <b>F</b>	300	220	91	55	1.6
SRFIR 450 45 <b>F</b>	450	220	91	55	2.2
SRFIR 600 45 <b>F</b>	600	220	91	55	2.9
SRFIR 750 45 <b>F</b>	750	220	91	55	3.4
SRFIR 900 45 <b>F</b>	900	220	91	55	5.5

Cat. Nos. given in the table are for inside risers. For outside risers substitute SRFIR for SRFOR. All fixed risers radius = 260 mm

Key : Replace the letter shown in red with your choice from the following options :

- F** = Finish : **G** (hot dip galvanised after manufacture), **D** (deep galvanised), **PG** (pre-galvanised steel), **S** (stainless steel), **E** (powder coated)

## 30° inside and outside risers – dimensions and weights

Cat. Nos.	Width	X	Y	Z	Weight (kg)
SRFIR 75 30 <b>F</b>	75	157	42	55	0.4
SRFIR 100 30 <b>F</b>	100	157	42	55	0.4
SRFIR 150 30 <b>F</b>	150	157	42	55	0.6
SRFIR 225 30 <b>F</b>	225	157	42	55	0.7
SRFIR 300 30 <b>F</b>	300	157	42	55	0.7
SRFIR 450 30 <b>F</b>	450	157	42	55	1.6
SRFIR 600 30 <b>F</b>	600	157	42	55	2.2
SRFIR 750 30 <b>F</b>	750	157	42	55	2.9
SRFIR 900 30 <b>F</b>	900	157	42	55	4.2

Cat. Nos. given in the table are for inside risers. For outside risers substitute SRFIR for SRFOR. All fixed risers radius = 260 mm

### Dimensions

X = Length of fitting from each end (excluding integral coupler)  
 Y = Length of fitting from each end (excluding integral coupler)  
 Z = End extension of integral coupler

### Weights

All weights given are in kilograms (kg) and are for hot dip galvanised G finish

To obtain the appropriate component weight in other finishes, multiply the given weight by the following factors :

- Deep galvanised (D) x 1.06
- Stainless steel (S) x 0.94
- Pre-galvanised (PG) x 0.96
- Powder coated (E) x 0.97

## Assembly

### Coupling detail

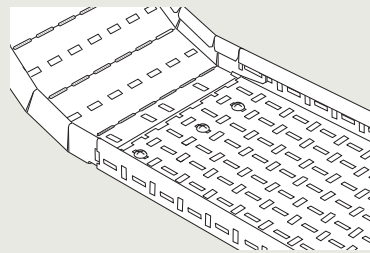

### 90° riser to straight length coupling

90° risers have integral couplers which fit into straight lengths whether they have been cut to length or not, without the need for further drilling. Each riser to length joint is secured with M6 x 12 bolts (roofing or pan head), nuts and washers or quick bolt fasteners (Cat. No. QBF), see p. 64. Fasteners are not included

Minimum number of fasteners per joint :

- Widths up to 225 = 2
- Widths 300 to 600 = 3
- Widths 750 and 900 = 4

### Fastener finishes

For risers with G, D and PG finishes, fasteners are galvanised or zinc plated

For risers with S finish, fasteners are stainless steel

For risers with E finish, the choice of material for fasteners will depend on the installation environment. For further information, contact us on +44 (0) 845 605 4333

All dimensions (mm) are nominal

→ SRF adjustable risers : see p. 71

# Swifts® SRF heavy duty fittings

## adjustable risers

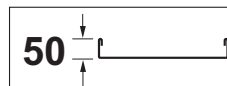

### ■ Dimensions and weights

The adjustable riser can be used as an inside or outside riser for any angle up to 90°

- Minimum radius = 200 mm
- Maximum radius = 300 mm
- Overall length when flat = 554 mm

### Dimensions

Cat. No. SRFAR **W F**

Used as inside riser

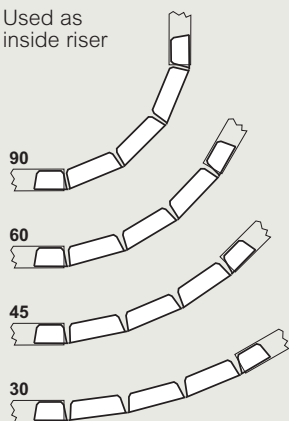

Used as outside riser

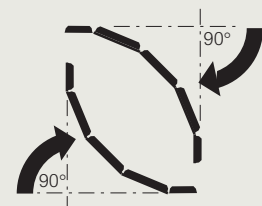
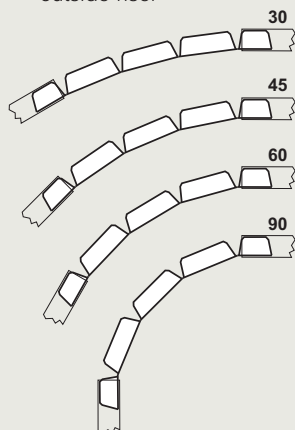

Cat. Nos.	Width (W)	Weight (kg)
SRFAR 75 <b>F</b>	75	0.7
SRFAR 100 <b>F</b>	100	0.8
SRFAR 150 <b>F</b>	150	1.1
SRFAR 225 <b>F</b>	225	1.8
SRFAR 300 <b>F</b>	300	2.4
SRFAR 450 <b>F</b>	450	3.4
SRFAR 600 <b>F</b>	600	4.4
SRFAR 750 <b>F</b>	750	5.5
SRFAR 900 <b>F</b>	900	6.5

### Weights

All weights given are in kilograms (kg) and are for hot dip galvanised G finish

To obtain the appropriate component weight in other finishes, multiply the given weight by the following factors :

- Deep galvanised (D) x 1.06
- Stainless steel (S) x 0.94
- Pre-galvanised (PG) x 0.96
- Powder coated (E) x 0.97

Key : Replace the letter shown in red with your choice from the following options :

- F** = Finish : **G** (hot dip galvanised after manufacture), **D** (deep galvanised), **PG** (pre-galvanised steel), **S** (stainless steel), **E** (powder coated)

### ■ Assembly

As many riser segments as necessary may be inserted into the end of the straight length, thus avoiding the need for cutting

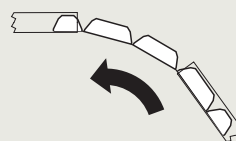

### Coupling detail

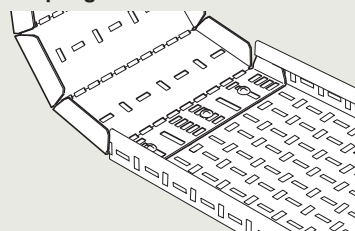

### Adjustable riser to straight length coupling

Adjustable risers fit into straight lengths whether they have been cut to length or not, without the need for further drilling

Each riser to length joint is secured with M6 x 12 bolts (roofing or pan head), nuts and washers or quick bolt fasteners (Cat. No. QBF), see p. 64. Fasteners are not included

Minimum number of fasteners per joint :

- Widths up to 225 = 2
- Widths 300 to 600 = 3
- Widths 750 and 900 = 4

### Fastener finishes

For adjustable riser with G, D and PG finishes, fasteners are galvanised or zinc plated

For adjustable riser with S finish, fasteners are stainless steel

For adjustable riser with E finish, the choice of material for fasteners will depend on the installation environment. For further information, contact us on +44 (0) 845 605 4333

All dimensions (mm) are nominal

➔ SRF inside and outside risers : see p. 70

# Swifts® SRF heavy duty fittings

## extra long adjustable risers

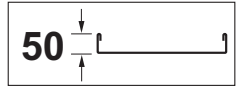

### ■ Dimensions and weights

The extra long adjustable riser can be used as an inside or outside riser for any angle up to 90°  
 Minimum radius = 200 mm  
 Maximum radius = 650 mm  
 Overall length when flat = 1 087 mm

### Dimensions

Cat. No. SRFAXR **W F**

Used as inside riser for any angle up to 90°

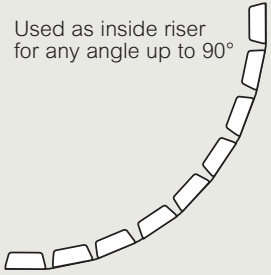

Used as outside riser for any angle up to 90°

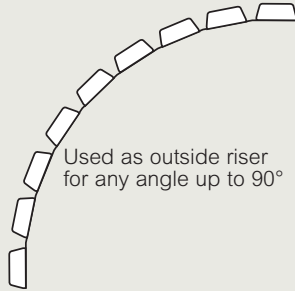

Used to avoid obstacles on site

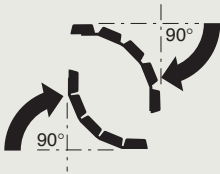

Cat. Nos.	Width (W)	Weight (kg)
<b>SRFAXR 75 F</b>	75	1.4
<b>SRFAXR 100 F</b>	100	1.6
<b>SRFAXR 150 F</b>	150	2.1
<b>SRFAXR 225 F</b>	225	3.7
<b>SRFAXR 300 F</b>	300	4.7
<b>SRFAXR 450 F</b>	450	6.8
<b>SRFAXR 600 F</b>	600	8.8
<b>SRFAXR 750 F</b>	750	10.8
<b>SRFAXR 900 F</b>	900	12.9

### Weights

All weights given are in kilograms (kg) and are for hot dip galvanised G finish  
 To obtain the appropriate component weight in other finishes, multiply the given weight by the following factors :

- Deep galvanised (D) x 1.06
- Stainless steel (S) x 0.94
- Pre-galvanised (PG) x 0.96
- Powder coated (E) x 0.97

Key : Replace the letter shown in red with your choice from the following options :

- F** = Finish : **G** (hot dip galvanised after manufacture), **D** (deep galvanised), **PG** (pre-galvanised steel), **S** (stainless steel), **E** (powder coated)

### ■ Assembly

As many riser segments as necessary may be inserted into the end of the straight length, thus avoiding the need for cutting

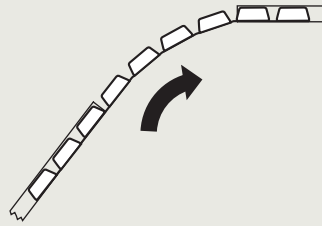

### Coupling detail

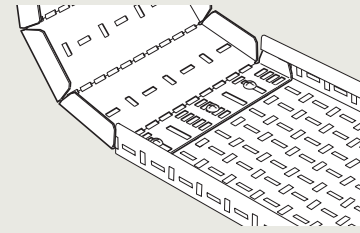

### Extra long adjustable riser to straight length coupling

Extra long adjustable risers fit into straight lengths whether they have been cut to length or not, without the need for further drilling  
 Each riser to length joint is secured with M6 x 12 bolts (roofing or pan head), nuts and washers or quick bolt fasteners (Cat. No. QBF), see p. 64. Fasteners are not included

Minimum number of fasteners per joint :

- Widths up to 225 = 2
- Widths 300 to 600 = 3
- Widths 750 and 900 = 4

### Fastener finishes

For adjustable risers with G, D and PG finishes, fasteners are galvanised or zinc plated  
 For adjustable risers with S finish, fasteners are stainless steel  
 For adjustable risers with E finish, the choice of material for fasteners will depend on the installation environment. For further information, contact us on +44 (0) 845 605 4333

All dimensions (mm) are nominal

→ SRF inside and outside risers : see p. 70

# Swifts® SRF heavy duty fittings

equal tees

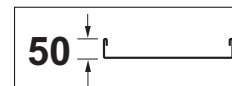

## ■ Dimensions and weights

### Dimensions

Cat. No. SRFT **W F**

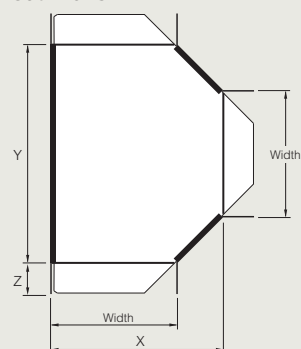

X = Length of fitting from each end (excluding integral coupler)  
 Y = Length of fitting from each end (excluding integral coupler)  
 Z = End extension of integral coupler

Cat. Nos.	Width	X	Y	Z	Weight (kg)
<b>SRFT 75 F</b>	75	197	320	55	1.0
<b>SRFT 100 F</b>	100	222	345	55	1.2
<b>SRFT 150 F</b>	150	272	395	55	1.6
<b>SRFT 225 F</b>	225	345	467	55	2.2
<b>SRFT 300 F</b>	300	420	542	55	3.8
<b>SRFT 450 F</b>	450	568	690	55	6.2
<b>SRFT 600 F</b>	600	718	840	55	9.1
<b>SRFT 750 F</b>	750	868	990	55	17.0
<b>SRFT 900 F</b>	900	1018	1140	55	22.6

### Weights

All weights given are in kilograms (kg) and are for hot dip galvanised G finish  
 To obtain the appropriate component weight in other finishes, multiply the given weight by the following factors :

- Deep galvanised (D) x 1.06
- Stainless steel (S) x 0.94
- Pre-galvanised (PG) x 0.96
- Powder coated (E) x 0.97

## ■ Assembly

### Coupling detail

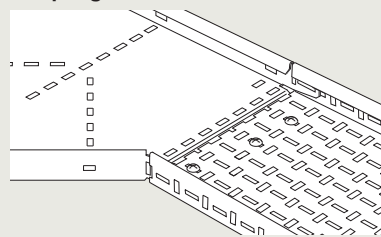

### Equal tee to straight length coupling

Equal tees have integral couplers which fit into straight lengths whether they have been cut to length or not, without the need for further drilling. Each equal tee to length joint is secured with M6 x 12 bolts (roofing or pan head), nuts and washers or quick bolt fasteners (Cat. No. QBF), see p. 64. Fasteners are not included.

Minimum number of fasteners per joint :

- Widths up to 225 = 2
- Widths 300 to 600 = 3
- Widths 750 and 900 = 4

### Fastener finishes

For equal tees with G, D and PG finishes, fasteners are galvanised or zinc plated.

For equal tees with S finish, fasteners are stainless steel.

For equal tees with E finish, the choice of material for fasteners will depend on the installation environment. For further information, contact us on +44 (0) 845 605 4333.

### Minimum bend radius for cables

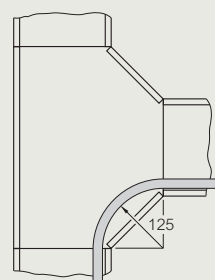

Minimum cable radius = 125 mm

Key : Replace the letter shown in red with your choice from the following options :

- F** = Finish : **G** (hot dip galvanised after manufacture), **D** (deep galvanised), **PG** (pre-galvanised steel), **S** (stainless steel), **E** (powder coated)

All dimensions (mm) are nominal

→ SRF unequal tees : see p. 74-75

# Swifts® SRF heavy duty fittings

## unequal tees

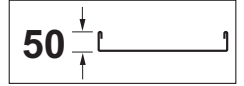

### ■ Dimensions and weights

#### Dimensions

Cat. No. SRFUT **W B F**

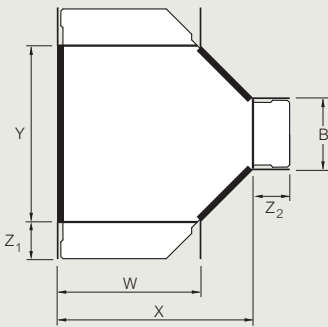

X = Length of fitting from each end (excluding integral coupler)

Y = Length of fitting from each end (excluding integral coupler)

Z<sub>1</sub> = End extension of integral coupler

Z<sub>2</sub> = End extension of integral coupler

Width (W)	Width (B)	Cat. Nos.	Dimensions (mm)				Weight (kg)
			X	Y	Z <sub>1</sub>	Z <sub>2</sub>	
75	100	SRFUT 75 100 <b>F</b>	197	345	55	55	1.1
	150	SRFUT 75 150 <b>F</b>	197	395	55	55	1.2
	225	SRFUT 75 225 <b>F</b>	195	470	55	55	1.4
	300	SRFUT 75 300 <b>F</b>	195	545	55	55	2.0
	450	SRFUT 75 450 <b>F</b>	194	690	55	55	2.6
	600	SRFUT 75 600 <b>F</b>	194	840	55	55	3.2
	750	SRFUT 75 750 <b>F</b>	194	990	55	55	3.8
100	900	SRFUT 75 900 <b>F</b>	194	1 140	55	55	5.7
	75	SRFUT 100 75 <b>F</b>	222	320	55	55	1.1
	150	SRFUT 100 150 <b>F</b>	222	395	55	55	1.3
	225	SRFUT 100 225 <b>F</b>	220	467	55	55	1.6
	300	SRFUT 100 300 <b>F</b>	220	545	55	55	2.2
	450	SRFUT 100 450 <b>F</b>	219	690	55	55	2.8
	600	SRFUT 100 600 <b>F</b>	219	840	55	55	3.4
150	750	SRFUT 100 750 <b>F</b>	219	990	55	55	4.1
	900	SRFUT 100 900 <b>F</b>	219	1 140	55	55	6.2
	75	SRFUT 150 75 <b>F</b>	272	320	55	55	1.3
	100	SRFUT 150 100 <b>F</b>	272	345	55	55	1.4
	225	SRFUT 150 225 <b>F</b>	271	467	55	55	1.8
	300	SRFUT 150 300 <b>F</b>	271	545	55	55	2.6
	450	SRFUT 150 450 <b>F</b>	268	690	55	55	3.3
225	600	SRFUT 150 600 <b>F</b>	268	840	55	55	4.0
	750	SRFUT 150 750 <b>F</b>	268	990	55	55	4.8
	900	SRFUT 150 900 <b>F</b>	268	1 140	55	55	7.2
	75	SRFUT 225 75 <b>F</b>	345	320	55	55	1.6
	100	SRFUT 225 100 <b>F</b>	345	342	55	55	1.7
	150	SRFUT 225 150 <b>F</b>	345	393	55	55	1.9
	300	SRFUT 225 300 <b>F</b>	345	542	55	55	3.2
900	450	SRFUT 225 450 <b>F</b>	343	690	55	55	4.0
	600	SRFUT 225 600 <b>F</b>	343	840	55	55	5.0
	750	SRFUT 225 750 <b>F</b>	343	990	55	55	5.7
	900	SRFUT 225 900 <b>F</b>	343	1 140	55	55	8.7

Width (W)	Width (B)	Cat. Nos.	Dimensions (mm)				Weight (kg)
			X	Y	Z <sub>1</sub>	Z <sub>2</sub>	
300	75	SRFUT 300 75 <b>F</b>	420	320	55	55	2.3
	100	SRFUT 300 100 <b>F</b>	420	342	55	55	2.5
	150	SRFUT 300 150 <b>F</b>	420	393	55	55	2.8
	225	SRFUT 300 225 <b>F</b>	420	467	55	55	3.3
	450	SRFUT 300 450 <b>F</b>	418	690	55	55	4.9
	600	SRFUT 300 600 <b>F</b>	418	840	55	55	5.9
	750	SRFUT 300 750 <b>F</b>	418	990	55	55	9.0
450	900	SRFUT 300 900 <b>F</b>	418	1 140	55	55	10.3
	75	SRFUT 450 75 <b>F</b>	568	320	55	55	3.0
	100	SRFUT 450 100 <b>F</b>	568	340	55	55	3.3
	150	SRFUT 450 150 <b>F</b>	568	390	55	55	3.7
	225	SRFUT 450 225 <b>F</b>	568	465	55	55	4.5
	300	SRFUT 450 300 <b>F</b>	568	540	55	55	5.1
	600	SRFUT 450 600 <b>F</b>	568	840	55	55	7.7
600	750	SRFUT 450 750 <b>F</b>	568	990	55	55	11.7
	900	SRFUT 450 900 <b>F</b>	568	1 140	55	55	13.3
	75	SRFUT 600 75 <b>F</b>	718	320	55	55	3.8
	100	SRFUT 600 100 <b>F</b>	718	340	55	55	4.1
	150	SRFUT 600 150 <b>F</b>	718	390	55	55	4.6
	225	SRFUT 600 225 <b>F</b>	718	465	55	55	5.5
	300	SRFUT 600 300 <b>F</b>	718	540	55	55	6.3
750	450	SRFUT 600 450 <b>F</b>	718	690	55	55	7.9
	750	SRFUT 600 750 <b>F</b>	718	990	55	55	14.3
	900	SRFUT 600 900 <b>F</b>	718	1 140	55	55	16.4
	75	SRFUT 750 75 <b>F</b>	868	320	55	55	6.2
	100	SRFUT 750 100 <b>F</b>	868	340	55	55	6.6
	150	SRFUT 750 150 <b>F</b>	868	390	55	55	7.4
	225	SRFUT 750 225 <b>F</b>	868	465	55	55	8.6
900	300	SRFUT 750 300 <b>F</b>	868	540	55	55	9.8
	450	SRFUT 750 450 <b>F</b>	868	690	55	55	12.2
	600	SRFUT 750 600 <b>F</b>	868	840	55	55	14.6
	900	SRFUT 750 900 <b>F</b>	868	1 140	55	55	19.5
	75	SRFUT 900 75 <b>F</b>	1 018	320	55	55	7.3
	100	SRFUT 900 100 <b>F</b>	1 018	340	55	55	7.7
	150	SRFUT 900 150 <b>F</b>	1 018	390	55	55	8.9
900	225	SRFUT 900 225 <b>F</b>	1 018	465	55	55	10.0
	300	SRFUT 900 300 <b>F</b>	1 018	540	55	55	11.4
	450	SRFUT 900 450 <b>F</b>	1 018	690	55	55	14.2
	600	SRFUT 900 600 <b>F</b>	1 018	840	55	55	17.0
	750	SRFUT 900 750 <b>F</b>	1 018	990	55	55	19.8

Key : Replace the letter shown in red with your choice from the following options :

- F** = Finish : **G** (hot dip galvanised after manufacture),
- D** (deep galvanised), **PG** (pre-galvanised steel),
- S** (stainless steel), **E** (powder coated)

# Swifts® SRF heavy duty fittings

## unequal tees (continued)

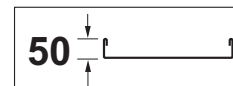

### ■ Dimensions and weights (continued)

#### Weights

All weights given are in kilograms (kg) and are for hot dip galvanised G finish

To obtain the appropriate component weight in other finishes, multiply the given weight by the following factors :

Deep galvanised (D)	x 1.06
Stainless steel (S)	x 0.94
Pre-galvanised (PG)	x 0.96
Powder coated (E)	x 0.97

### ■ Assembly

#### Coupling detail

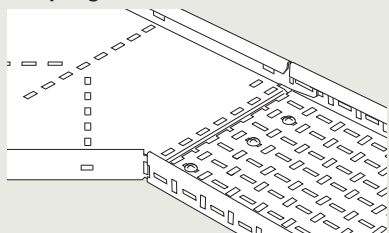

#### Unequal tee to straight length coupling

Unequal tees have integral couplers which fit into straight lengths whether they have been cut to length or not, without the need for further drilling

Each unequal tee to length joint is secured with M6 x 12 bolts (roofing or pan head), nuts and washers or quick bolt fasteners (Cat. No. QBF), see p. 64. Fasteners are not included

Minimum number of fasteners per joint :

Widths up to 225	= 2
Widths 300 to 600	= 3
Widths 750 and 900	= 4

#### Fastener finishes

For unequal tees with G, D and PG finishes, fasteners are galvanised or zinc plated

For unequal tees with S finish, fasteners are stainless steel

For unequal tees with E finish, the choice of material for fasteners will depend on the installation environment. For further information, contact us on +44 (0) 845 605 4333

#### Minimum bend radius for cables

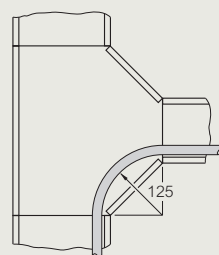

Minimum cable radius = 125 mm

All dimensions (mm) are nominal

→ SRF equal tees : see p. 73

# Swifts® SRF heavy duty fittings

## 4 way crosspieces

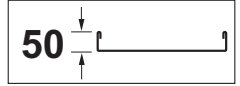

### ■ Dimensions and weights

#### Dimensions

Cat. No. SRFX **W F**

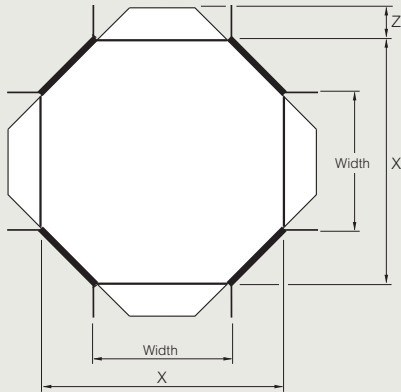

X = Length of fitting from each end (excluding integral coupler)  
 Y = Length of fitting from each end (excluding integral coupler)  
 Z = End extension of integral coupler

Cat. Nos.	Width	X	Z	Weight (kg)
<b>SRFX 75 F</b>	75	320	55	1.3
<b>SRFX 100 F</b>	100	345	55	1.5
<b>SRFX 150 F</b>	150	395	55	1.9
<b>SRFX 225 F</b>	225	467	55	2.7
<b>SRFX 300 F</b>	300	542	55	4.5
<b>SRFX 450 F</b>	450	690	55	7.3
<b>SRFX 600 F</b>	600	840	55	10.6
<b>SRFX 750 F</b>	750	990	55	18.8
<b>SRFX 900 F</b>	900	1 140	55	25.3

#### Weights

All weights given are in kilograms (kg) and are for hot dip galvanised G finish  
 To obtain the appropriate component weight in other finishes, multiply the given weight by the following factors :

- Deep galvanised (D) x 1.06
- Stainless steel (S) x 0.94
- Pre-galvanised (PG) x 0.96
- Powder coated (E) x 0.97

### ■ Assembly

#### Coupling detail

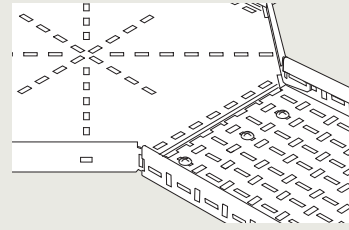

#### 4 way crosspiece to straight length coupling

Crosspieces have integral couplers which fit into straight lengths whether they have been cut to length or not, without the need for further drilling

Each crosspiece to length joint is secured with M6 x 12 bolts (roofing or pan head), nuts and washers or quick bolt fasteners (Cat. No. QBF), see p. 64. Fasteners are not included

Minimum number of fasteners per joint :

Widths up to 225 = 2  
 Widths 300 to 600 = 3  
 Widths 750 and 900 = 4

#### Fastener finishes

For crosspieces with G, D and PG finishes, fasteners are galvanised or zinc plated

For crosspieces with S finish, fasteners are stainless steel

For crosspieces with E finish, the choice of material for fasteners will depend on the installation environment. For further information, contact us on +44 (0) 845 605 4333

#### Minimum bend radius for cables

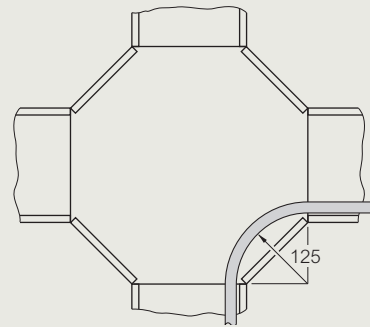

Minimum cable radius = 125 mm

Key : Replace the letter shown in red with your choice from the following options :

**F** = Finish : **G** (hot dip galvanised after manufacture),  
**D** (deep galvanised), **PG** (pre-galvanised steel),  
**S** (stainless steel), **E** (powder coated)

All dimensions (mm) are nominal

# Swifts® SRF heavy duty fittings

## straight reducers

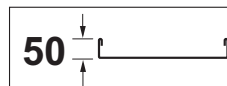

### ■ Dimensions and weights

#### Dimensions

Cat. No. SRFR **W** **K** **F**

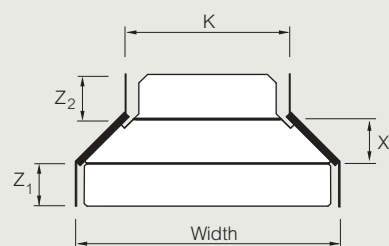

X = Length of fitting from each end (excluding integral coupler)

Z<sub>1</sub> = End extension of integral coupler

Z<sub>2</sub> = End extension of integral coupler

K = Reduced width

Width	Width (K)	Cat. Nos.	Dimensions (mm)			Weight (kg)
			X	Z <sub>1</sub>	Z <sub>2</sub>	
100	75	SRFR 100 75 <b>F</b>	100	55	55	0.3
	75	SRFR 150 75 <b>F</b>	100	55	55	0.4
150	100	SRFR 150 100 <b>F</b>	100	55	55	0.4
	75	SRFR 225 75 <b>F</b>	100	55	55	0.5
225	100	SRFR 225 100 <b>F</b>	100	55	55	0.5
	150	SRFR 225 150 <b>F</b>	100	55	55	0.6
300	75	SRFR 300 75 <b>F</b>	150	55	55	0.6
	100	SRFR 300 100 <b>F</b>	100	55	55	0.6
	150	SRFR 300 150 <b>F</b>	100	55	55	0.6
	225	SRFR 300 225 <b>F</b>	100	55	55	0.6
450	75	SRFR 450 75 <b>F</b>	300	55	55	1.5
	100	SRFR 450 100 <b>F</b>	300	55	55	1.5
	150	SRFR 450 150 <b>F</b>	150	55	55	1.0
	225	SRFR 450 225 <b>F</b>	150	55	55	1.0
	300	SRFR 450 300 <b>F</b>	100	55	55	1.1
600	75	SRFR 600 75 <b>F</b>	300	55	55	1.8
	100	SRFR 600 100 <b>F</b>	300	55	55	1.8
	150	SRFR 600 150 <b>F</b>	300	55	55	1.9
	225	SRFR 600 225 <b>F</b>	300	55	55	2.0
	300	SRFR 600 300 <b>F</b>	150	55	55	2.7
750	450	SRFR 600 450 <b>F</b>	100	55	55	2.7
	75	SRFR 750 75 <b>F</b>	450	55	55	2.6
	100	SRFR 750 100 <b>F</b>	450	55	55	2.6
	150	SRFR 750 150 <b>F</b>	300	55	55	2.6
	225	SRFR 750 225 <b>F</b>	300	55	55	2.9
	300	SRFR 750 300 <b>F</b>	300	55	55	3.1
900	450	SRFR 750 450 <b>F</b>	300	55	55	3.4
	600	SRFR 750 600 <b>F</b>	100	55	55	3.8
	75	SRFR 900 75 <b>F</b>	450	55	55	4.2
	100	SRFR 900 100 <b>F</b>	450	55	55	4.4
	150	SRFR 900 150 <b>F</b>	450	55	55	4.4
	225	SRFR 900 225 <b>F</b>	450	55	55	4.6
	300	SRFR 900 300 <b>F</b>	300	55	55	5.5
450	SRFR 900 450 <b>F</b>	300	55	55	5.8	
600	SRFR 900 600 <b>F</b>	300	55	55	6.1	
750	SRFR 900 750 <b>F</b>	100	55	55	6.3	

### ■ Dimensions and weights (continued)

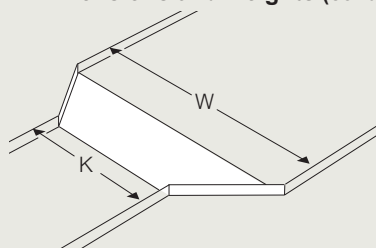

To create the Cat. No. add the main run width (W), the reduced run width (K) and the finish (F)

Example :

For a hot dip galvanised reducer reducing from 300 mm to 150 mm : SRFR 300 150 G

#### Weights

All weights given are in kilograms (kg) and are for hot dip galvanised G finish

To obtain the appropriate component weight in other finishes, multiply the given weight by the following factors :

Deep galvanised (D) x 1.06

Stainless steel (S) x 0.94

Pre-galvanised (PG) x 0.96

Powder coated (E) x 0.97

#### ■ Assembly

##### Coupling detail

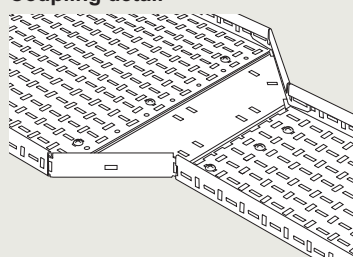

##### Reducer to straight length coupling

Reducers have integral couplers which fit into straight lengths whether they have been cut to length or not, without the need for further drilling

Each reducer to length joint is secured with M6 x 12 bolts (roofing or pan head), nuts and washers or quick bolt fasteners (Cat. No. QBF), see p. 64. Fasteners are not included

Minimum number of fasteners per joint :

Widths up to 225 = 2

Widths 300 to 600 = 3

Widths 750 and 900 = 4

##### Fastener finishes

For reducers with G, D and PG finishes, fasteners are galvanised or zinc plated

For reducers with S finish, fasteners are stainless steel

For reducers with E finish, the choice of material for fasteners will depend on the installation environment. For further information, contact us on +44 (0) 845 605 4333

Key : Replace the letter shown in red with your choice from the following options :

- F** = Finish : **G** (hot dip galvanised after manufacture), **D** (deep galvanised), **PG** (pre-galvanised steel), **S** (stainless steel), **E** (powder coated)

All dimensions (mm) are nominal

# Swifts® SRF heavy duty fittings

## SRF to MRF straight reducers

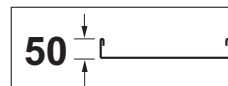

### ■ Dimensions and weights

Cat. No. SRFMRFR **W F**

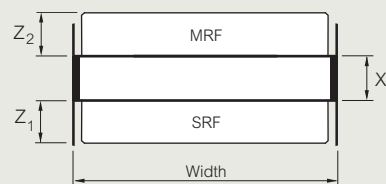

Cat. Nos.	Width	X	Y	Z	Weight (kg)
<b>SRFMRFR 75 F</b>	75	150	55	55	0.2
<b>SRFMRFR 100 F</b>	100	150	55	55	0.3
<b>SRFMRFR 150 F</b>	150	150	55	55	0.4
<b>SRFMRFR 225 F</b>	225	150	55	55	0.5
<b>SRFMRFR 300 F</b>	300	150	55	55	0.6
<b>SRFMRFR 450 F</b>	450	150	55	55	1.1
<b>SRFMRFR 600 F</b>	600	150	55	55	1.4
<b>SRFMRFR 750 F</b>	750	150	55	55	1.4
<b>SRFMRFR 900 F</b>	900	150	55	55	2.2

### Dimensions

X = Length of fitting from each end (excluding integral coupler)

Z<sub>1</sub> = End extension of integral coupler

Z<sub>2</sub> = End extension of integral coupler

### Weights

All weights given are in kilograms (kg) and are for hot dip galvanised G finish

To obtain the appropriate component weight in other finishes, multiply the given weight by the following factors :

Deep galvanised (D)	x 1.06
Stainless steel (S)	x 0.94
Pre-galvanised (PG)	x 0.96
Powder coated (E)	x 0.97

### ■ Assembly

#### Coupling detail

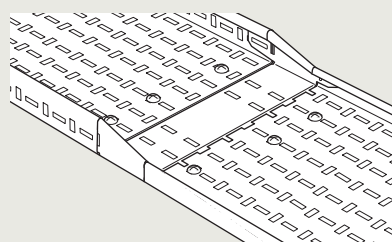

#### Straight reducer to straight length coupling

Reducers have integral couplers which fit into straight lengths whether they have been cut to length or not, without the need for further drilling. Each reducer to length joint is secured with M6 x 12 bolts (roofing or pan head), nuts and washers or quick bolt fasteners (Cat. No. QBF), see p. 64. Fasteners are not included.

Minimum number of fasteners per joint :

Widths up to 225 = 2

Widths 300 to 600 = 3

Widths 750 and 900 = 4

#### Fastener finishes

For reducers with G, D and PG finishes, fasteners are galvanised or zinc plated

For reducers with S finish, fasteners are stainless steel

For reducers with E finish, the choice of material for fasteners will depend on the installation environment. For further information, contact us on +44 (0) 845 605 4333

Key : Replace the letter shown in red with your choice from the following options :

**F** = Finish : **G** (hot dip galvanised after manufacture),  
**D** (deep galvanised), **PG** (pre-galvanised steel),  
**S** (stainless steel), **E** (powder coated)

All dimensions (mm) are nominal

→ MRF straight lengths : see p. 46

→ SRF straight lengths : see p. 62

# Swifts® SRF heavy duty fittings

## handed reducers

### ■ On-site fabrication of fittings

For on-site fabrication of fittings, including left or right handed reducers, use universal brackets and fishplates, see p. 85  
 Left and right handed reducers are not currently available as a standard factory fabricated fitting

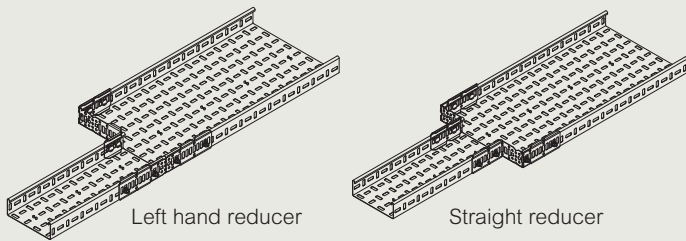

Left hand reducer

Straight reducer

### ■ Dimensions and weights

Figures show approximated reduced widths

		SRFL															
Smaller Size	75 mm		100 mm		150 mm		225 mm		300 mm		450 mm		600 mm		750 mm		
Larger Size	Handed	Straight	Handed	Straight	Handed	Straight	Handed	Straight	Handed	Straight	Handed	Straight	Handed	Straight	Handed	Straight	
100 mm	25	12	–	–	–	–	–	–	–	–	–	–	–	–	–	–	
150 mm	75	37	50	25	–	–	–	–	–	–	–	–	–	–	–	–	
225 mm	150	75	125	62	75	37	–	–	–	–	–	–	–	–	–	–	
300 mm	–	112	200	100	150	75	75	37	–	–	–	–	–	–	–	–	
450 mm	–	–	–	175	–	150	–	112	150	75	–	–	–	–	–	–	
600 mm	–	–	–	–	–	–	–	187	–	150	150	75	–	–	–	–	
750 mm	–	–	–	–	–	–	–	–	–	–	–	150	150	75	–	–	
900 mm	–	–	–	–	–	–	–	–	–	–	–	–	–	150	150	75	

→ Universal bracket : see p. 65

→ Universal fishplate : see p. 65

All dimensions (mm) are nominal