

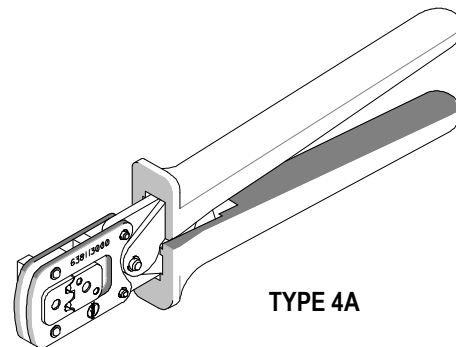

Hand Crimp Tool Specification Sheet Order No. 63811-6200



FEATURES

- % A full cycle ratcheting hand tool ensures complete crimps
- % Ergonomically designed soft handles
- % Precisely designed crimping profiles with simple contact positioning
- % Easy handling due to outstanding force ratio

SCOPE

Products: MX150™ 1.50mm (.591") Pitch, MX150™ Receptacle Female Crimp Terminals, 0.50 and 0.75 Metric wires.

Terminal Series No.	Terminal Order No.				Wire Size		Insulation Diameter		Strip Length	
	● Reel				AWG	mm ²	mm	In.	mm	In.
33001	33001-2005	33001-2023	33001-3005	33001-3023	Metric Only	0.50	1.40-1.60	.055-.063	4.70-5.60	.185-.220
	33001-4003	33001-4023	33001-5003	33001-5023						
	33001-2004	33001-2022	33001-3004	33001-3022	Metric Only	0.75	1.70-1.90	.067-.075	4.70-5.60	.185-.220
	33001-4002	33001-4022	33001-5002	33001-5022						
33012	33012-2003	33012-2023	33012-3003	33012-3023	Metric Only	0.50	1.40-1.60	.055-.063	4.70-5.60	.185-.220
	33012-2002	33012-2022	33012-3002	33012-3022	Metric Only	0.75	1.70-1.90	.067-.075	4.70-5.60	.185-.220
34750	34750-0003	34750-1003			Metric Only	0.50	1.40-1.60	.055-.063	4.70-5.60	.185-.220
	34750-0002	34750-1002			Metric Only	0.75	1.70-1.90	.067-.075	4.70-5.60	.185-.220

● Customer to cut off terminal from reel: 0.50mm (.020") maximum Cut-off Tab.
 Terminals were validated per USCAR-21 using the following wire specifications:
 M1L-123A (TXL), M1L-135A1 (UTX), and M1L-126A1 (metric-TXL).
 Customers are required to complete validation testing if tooling purchased outside Molex Inc.
 and/or wire specifications are different than above.

DEFINITION OF TERMS

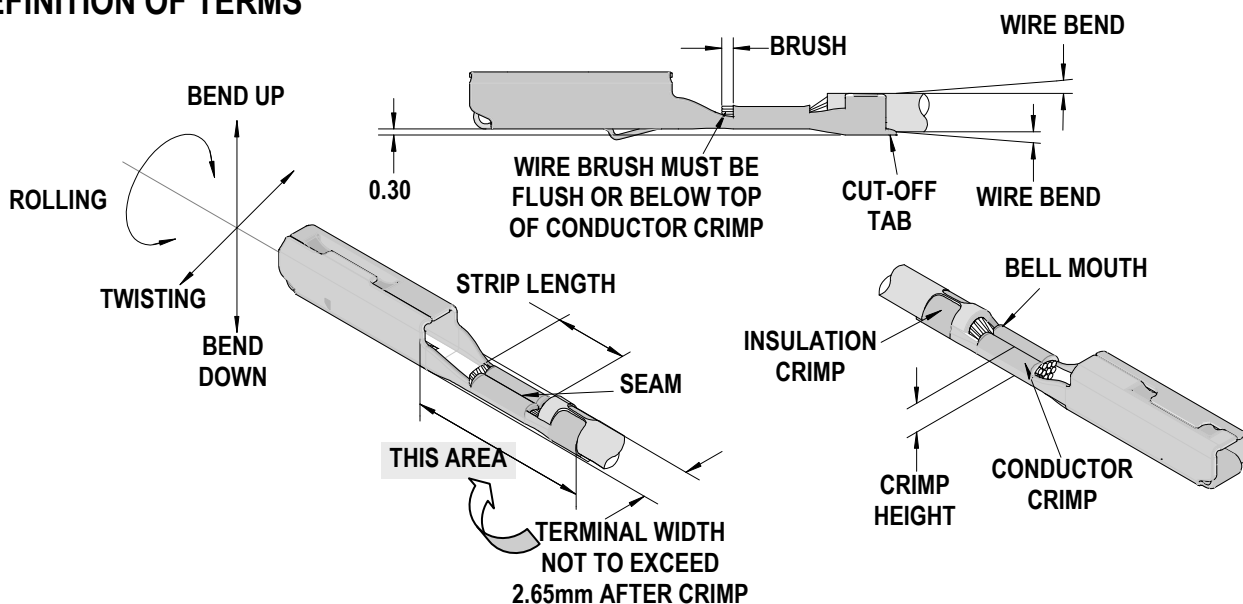

CRIMP SPECIFICATION

Terminal Series No.	Bell mouth		◆ Conductor Brush	
	mm	In.	mm	In.
33001	0.25-1.25	.010-.049	0.15-0.40	.006-.016
33012	0.25-1.25	.010-.049	0.15-0.40	.006-.016
34750	0.25-1.25	.010-.049	0.15-0.40	.006-.016

◆ Wire brush to be below top of conductor crimp.

Terminal Series No.	Bend up	Bend down	Twist Roll	Seam Seam shall not be open and no wire allowed out of the crimping area
	Degree			
33001	✗ Crimped terminals and up to 5mm of wire past the insulator cutoff tab must freely fit in the Checking Aid, Part No. 63868-2008			
33012				
34750				

✗ Order Separately

After crimping, the crimp profiles should measure the following:

Terminal Series No.	Wire Size		Conductor				Profile AWG	
			Crimp Height		Crimp Width		0.50	0.75
	AWG	mm ²	mm	In.	mm	In.		
33001	Metric Only	0.50	1.05-1.15	.041-.045	1.50-1.70	.059-.067	X	
	Metric Only	0.75	1.20-1.30	.047-.051	2.05-2.25	.081-.089		X
33012	Metric Only	0.50	1.05-1.15	.041-.045	1.50-1.70	.059-.067	X	
	Metric Only	0.75	1.20-1.30	.047-.051	2.05-2.25	.081-.089		X
34750	Metric Only	0.50	1.05-1.15	.041-.045	1.50-1.70	.059-.067	X	
	Metric Only	0.75	1.20-1.30	.047-.051	2.05-2.25	.081-.089		X

Terminal Series No.	Wire Size		Insulation				Pull Force Minimum	
			Crimp Height		Crimp Width		N	Lb.
	AWG	mm ²	mm	In.	mm	In.		
33001	Metric Only	0.50	1.70-1.90	.067-.075	1.80-2.00	.071-.079	75.6	17.0
	Metric Only	0.75	1.85-2.05	.073-.081	2.00-2.20	.079-.087	89.9	20.2
33012	Metric Only	0.50	1.70-1.90	.067-.075	1.80-2.00	.071-.079	75.6	17.0
	Metric Only	0.75	1.85-2.05	.073-.081	2.00-2.20	.079-.087	89.9	20.2
34750	Metric Only	0.50	1.70-1.90	.067-.075	1.80-2.00	.071-.079	75.6	17.0
	Metric Only	0.75	1.85-2.05	.073-.081	2.00-2.20	.079-.087	89.9	20.2

T Tool Qualification Notes:

1. Pull Force should be measured with no influence from the insulation crimp.
2. The above specifications are guidelines to an optimum crimp.

OPERATION

Open the tool by squeezing the handles together, at the end of the closing stroke, the ratchet mechanism will release the handles, and the hand tool will spring open.

Crimping Terminals

1. Lift the wire stop blade up.
2. Insert the terminal fully into the correct die profile and the locator slot until the terminal is fully seated and stops.
3. Push down the wire stop blade. Make sure the wire stop blade is fully seated on the terminal behind the conductor grip section.
4. Slide the pre-stripped wire into the terminal; make sure to aim the wire end towards the tip point on the wire stop blade. See Figure 1. Align the wire so that it is parallel to, and sitting into the terminal. Maintain a light and constant pressure on the wire that is seated in the terminal at all times. (Do not let go of the wire.) Be sure to hold the wire and terminal in place until the terminal is fully crimped. See Figure 2.

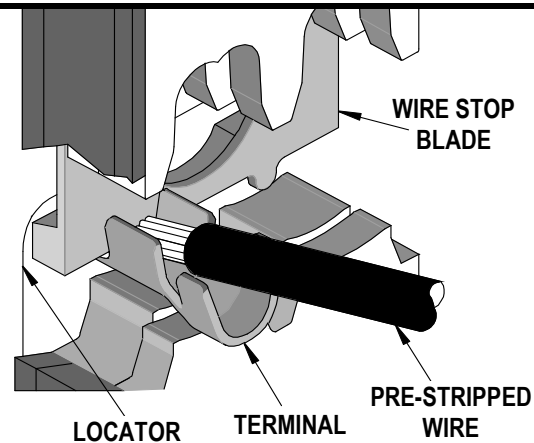

Figure 1

CAUTION: Pushing the wire against the Wire Stop Blade with too much force can cause wire strands to bend up and above the top of the conductor crimp. If this occurs, depress strands below the top of the conductor crimp to prevent matte seal damage.

5. Close the tool until the ratchet releases.
6. Carefully remove the crimped terminal.

Note: To maintain good brush control and a consistent bell mouth the crimping instructions must be followed.

Maintenance

It is recommended that each operator of the tool be made aware of, and responsible for, the following maintenance steps:

1. Remove dust, moisture, and other contaminants with a clean brush, or soft, lint free cloth.
2. Do not use any abrasive materials that could damage the tool.
3. Make certain all pins; pivot points and bearing surfaces are protected with a thin coat of high quality machine oil. Do not oil excessively.
4. When tool is not in use, keep the handles closed to prevent objects from becoming lodged in the crimping dies, and store the tool in a clean, dry area.

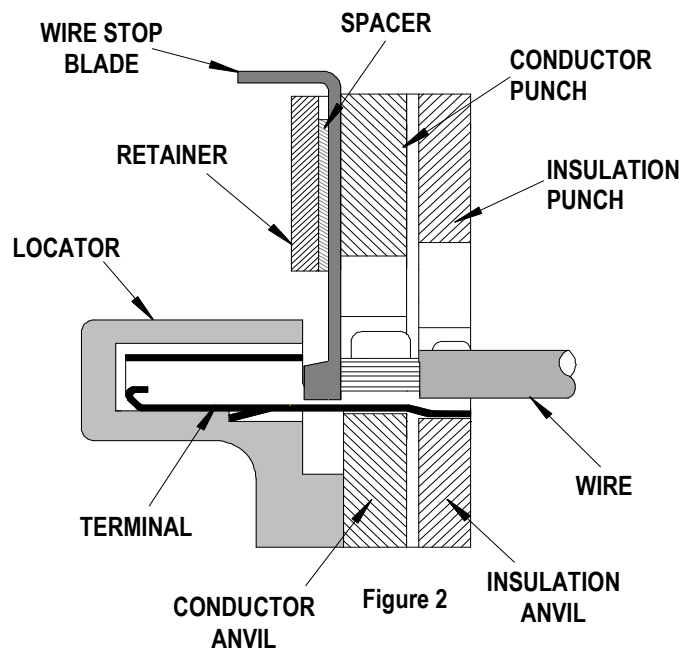

Figure 2

Miscrimps or Jams (See Figure 3)

Should this tool ever become stuck or jammed in a partially closed position, **Do Not force the handles open or closed.** The tool will open easily by pushing the ratchet release lever.

Warranty

This tool is for electrical terminal crimping purposes only. This tool is made of the best quality materials. All vital components are long life tested. All tools are warranted to be free of manufacturing defects for a period of **30 days**. Should such a defect occur, we would exchange the tool free of charge. This will not be applicable to altered, misused, or damaged tools. This tool is designed for hand use only. Any clamping, fixturing, or use of handle extensions voids this warranty.

Hand held crimping tools are intended for low volume, prototyping, or repair requirements only.

CAUTION: Repetitive use of this tool should be avoided.

Notes:

1. This tool should only be used for the terminals and wire gauges specified on this sheet.
2. This tool is not adjustable. Variations in tools, terminals, and wire stranding and insulation types may affect crimp height.
3. This tool is intended for standard conductor sizes. It may not give a good insulation crimp support for all insulation sizes.
4. Molex does not repair hand tools (see warranty above). The replacement parts listed are the only parts available for repair. If the handles or crimp tooling is damaged or worn, a new tool must be purchased.
5. Pull force should be used as the final criteria for an acceptable crimp. Pull force is measured with no influence from the insulation crimp. The insulation should be stripped long (1/2 in.) so the insulation grips on the terminal do not grip the wire insulation or the conductor. Refer to Molex Quality Crimping Handbook 63800-0029 for additional information on crimping and crimp testing.
6. Molex does not certify crimp hand tools.

CAUTION: Molex crimp specifications are valid only when used with Molex terminals, applicators and tooling.

PARTS LIST

Item Number	Order Number	Description	Quantity
1	63600-0520	Crimping Spring	2
2	63811-5975	Locator	1
3	63600-0525	Handle Spring	1

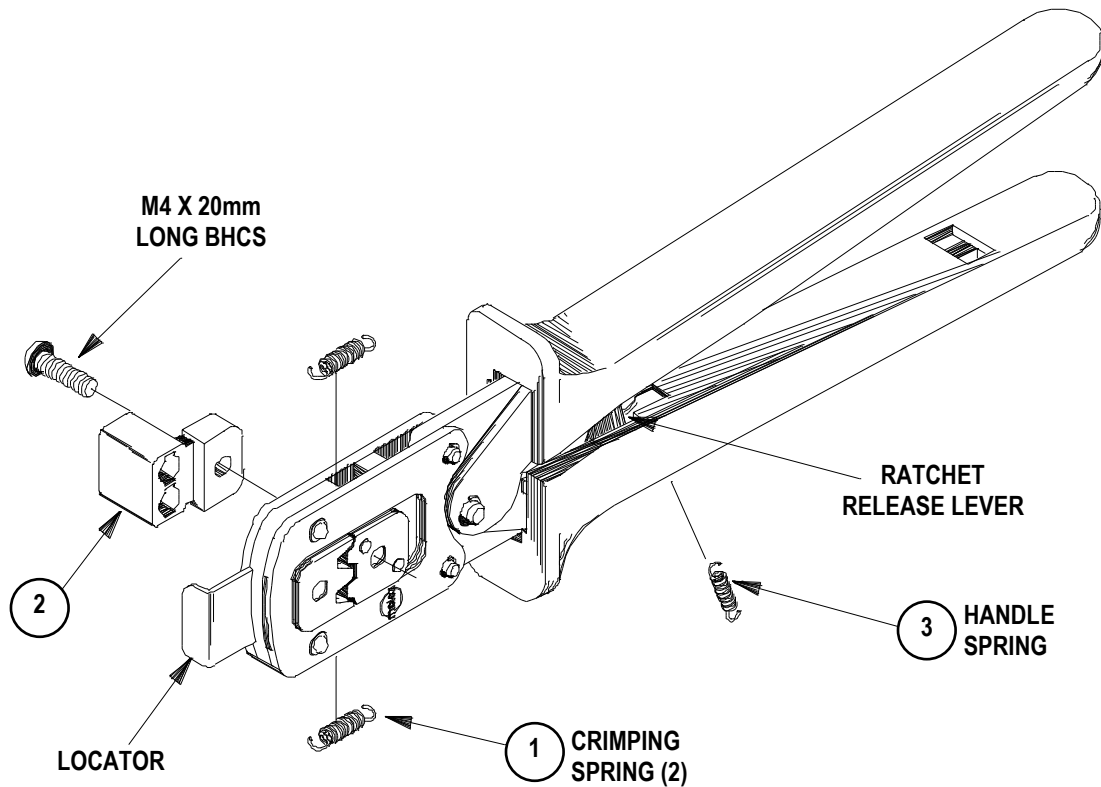

Figure 3

Americas Headquarters
 Lisle, Illinois 60532 U.S.A.
 1-800-78MOLEX
 amerinfo@molex.com

Far East North Headquarters
 Yamato, Kanagawa, Japan
 81-462-65-2324
 feninfo@molex.com

Far East South Headquarters
 Jurong, Singapore
 65-6-268-6868
 fesinfo@molex.com

European Headquarters
 Munich, Germany
 49-89-413092-0
 eurinfo@molex.com

Corporate Headquarters
 2222 Wellington Ct.
 Lisle, IL 60532 U.S.A.
 630-969-4550
 Fax: 630-969-1352

Visit our Web site at <http://www.molex.com>