



eZ80L92

Product Specification

PRELIMINARY

PS013010-0903



This publication is subject to replacement by a later edition. To determine whether a later edition exists, or to request copies of publications, contact:

ZiLOG Worldwide Headquarters

532 Race Street
San Jose, CA 95126
Telephone: 408.558.8500
Fax: 408.558.8300
www.ZiLOG.com

Document Disclaimer

ZiLOG is a registered trademark of ZiLOG Inc. in the United States and in other countries. All other products and/or service names mentioned herein may be trademarks of the companies with which they are associated.

©2003 by ZiLOG, Inc. All rights reserved. Information in this publication concerning the devices, applications, or technology described is intended to suggest possible uses and may be superseded. ZiLOG, INC. DOES NOT ASSUME LIABILITY FOR OR PROVIDE A REPRESENTATION OF ACCURACY OF THE INFORMATION, DEVICES, OR TECHNOLOGY DESCRIBED IN THIS DOCUMENT. ZiLOG ALSO DOES NOT ASSUME LIABILITY FOR INTELLECTUAL PROPERTY INFRINGEMENT RELATED IN ANY MANNER TO USE OF INFORMATION, DEVICES, OR TECHNOLOGY DESCRIBED HEREIN OR OTHERWISE. Devices sold by ZiLOG, Inc. are covered by warranty and limitation of liability provisions appearing in the ZiLOG, Inc. Terms and Conditions of Sale. ZiLOG, Inc. makes no warranty of merchantability or fitness for any purpose Except with the express written approval of ZiLOG, use of information, devices, or technology as critical components of life support systems is not authorized. No licenses are conveyed, implicitly or otherwise, by this document under any intellectual property rights.



Table of Contents

| | |
|--|-----|
| List of Figures | vii |
| List of Tables | ix |
| Architectural Overview | 1 |
| Features | 1 |
| Block Diagram | 2 |
| Pin Description | 4 |
| Pin Characteristics | 20 |
| Register Map | 25 |
| eZ80 [®] CPU Core | 32 |
| Features | 32 |
| New and Improved Instructions | 32 |
| Reset | 34 |
| RESET Operation | 34 |
| Low-Power Modes | 35 |
| Overview | 35 |
| SLEEP Mode | 35 |
| HALT Mode | 36 |
| Clock Peripheral Power-Down Registers | 36 |
| General-Purpose Input/Output | 39 |
| GPIO Overview | 39 |
| GPIO Operation | 39 |
| GPIO Interrupts | 42 |
| GPIO Control Registers | 43 |
| Interrupt Controller | 45 |
| Maskable Interrupts | 45 |
| Nonmaskable Interrupts | 47 |
| Chip Selects and Wait States | 48 |
| Memory and I/O Chip Selects | 48 |
| Memory Chip Select Operation | 48 |
| I/O Chip Select Operation | 50 |
| Wait States | 51 |
| WAIT Input Signal | 51 |
| Chip Selects During Bus Request/Bus Acknowledge Cycles | 52 |
| Bus Mode Controller | 53 |
| eZ80 Bus Mode | 53 |



| | |
|---|-----|
| Z80 Bus Mode | 53 |
| Intel Bus Mode | 55 |
| Motorola Bus Mode | 62 |
| Chip Select Registers | 66 |
| Watch-Dog Timer | 71 |
| Watch-Dog Timer Overview | 71 |
| Watch-Dog Timer Operation | 72 |
| Watch-Dog Timer Registers | 73 |
| Programmable Reload Timers | 75 |
| Programmable Reload Timers Overview | 75 |
| Programmable Reload Timer Operation | 76 |
| Programmable Reload Timer Registers | 80 |
| Real-Time Clock | 86 |
| Real-Time Clock Overview | 86 |
| Real-Time Clock Alarm | 87 |
| Real-Time Clock Oscillator and Source Selection | 87 |
| Real-Time Clock Battery Backup | 87 |
| Real-Time Clock Recommended Operation | 87 |
| Real-Time Clock Registers | 88 |
| Universal Asynchronous Receiver/Transmitter | 102 |
| UART Functional Description | 102 |
| UART Interrupts | 104 |
| UART Recommended Usage | 105 |
| Baud Rate Generator | 107 |
| BRG Control Registers | 107 |
| UART Registers | 109 |
| Infrared Encoder/Decoder | 120 |
| Functional Description | 120 |
| Transmit | 121 |
| Receive | 121 |
| Jitter | 122 |
| Infrared Encoder/Decoder Signal Pins | 122 |
| Loopback Testing | 123 |
| Serial Peripheral Interface | 125 |
| SPI Signals | 126 |
| SPI Functional Description | 128 |
| SPI Flags | 128 |
| SPI Baud Rate Generator | 129 |
| Data Transfer Procedure with SPI Configured as the Master | 130 |



| | |
|--|-----|
| Data Transfer Procedure with SPI Configured as a Slave | 130 |
| SPI Registers | 130 |
| I ² C Serial I/O Interface | 135 |
| I ² C General Characteristics | 135 |
| Transferring Data | 137 |
| Clock Synchronization | 138 |
| Operating Modes | 140 |
| I ² C Registers | 147 |
| ZiLOG Debug Interface | 156 |
| Introduction | 156 |
| ZDI-Supported Protocol | 157 |
| ZDI Clock and Data Conventions | 158 |
| ZDI Start Condition | 158 |
| ZDI Register Addressing | 160 |
| ZDI Write Operations | 161 |
| ZDI Read Operations | 162 |
| Operation of the eZ80L92 during ZDI BREAKpoints | 163 |
| Bus Requests During ZDI Debug Mode | 163 |
| ZDI Write-Only Registers | 164 |
| ZDI Read-Only Registers | 166 |
| ZDI Register Definitions | 166 |
| On-Chip Instrumentation | 182 |
| Introduction to On-Chip Instrumentation | 182 |
| OCI Activation | 182 |
| OCI Interface | 183 |
| OCI Information Requests | 184 |
| eZ80 [®] CPU Instruction Set | 185 |
| Op-Code Map | 189 |
| On-Chip Oscillators | 196 |
| 20 MHz Primary Crystal Oscillator Operation | 196 |
| 50MHz Primary Crystal Oscillator Operation | 197 |
| 32 KHz Real-Time Clock Crystal Oscillator Operation | 199 |
| Electrical Characteristics | 201 |
| Absolute Maximum Ratings | 201 |
| DC Characteristics | 202 |
| AC Characteristics | 204 |
| External Memory Read Timing | 204 |
| External Memory Write Timing | 206 |



| | |
|--|-----|
| External I/O Read Timing | 208 |
| External I/O Write Timing | 209 |
| Wait State Timing for Read Operations | 211 |
| Wait State Timing for Write Operations | 212 |
| General Purpose I/O Port Input Sample Timing | 213 |
| General Purpose I/O Port Output Timing | 213 |
| External Bus Acknowledge Timing | 214 |
| External System Clock Driver (PHI) Timing | 214 |
| Packaging | 215 |
| Ordering Information | 216 |
| Part Number Description | 216 |
| Precharacterization Product | 217 |
| Document Information | 218 |
| Document Number Description | 218 |
| Change Log | 218 |
| Index | 219 |
| Customer Feedback Form | 227 |



List of Figures

| | | |
|------------|---|-----|
| Figure 1. | eZ80L92 Block Diagram | 3 |
| Figure 2. | 100-Pin LQFP Configuration of the eZ80L92 | 4 |
| Figure 3. | GPIO Port Pin Block Diagram | 42 |
| Figure 4. | Memory Chip Select Example | 49 |
| Figure 5. | Wait Input Sampling Block Diagram | 51 |
| Figure 6. | Wait State Operation Example (Read Operation) | 52 |
| Figure 7. | Z80 Bus Mode Read Timing Example | 54 |
| Figure 8. | Z80 Bus Mode Write Timing Example | 55 |
| Figure 9. | Intel™ Bus Mode Signal and Pin Mapping | 56 |
| Figure 10. | Intel™ Bus Mode Read Timing Example (Separate Address and Data Buses) | 58 |
| Figure 11. | Intel™ Bus Mode Write Timing Example (Separate Address and Data Buses) | 59 |
| Figure 12. | Intel™ Bus Mode Read Timing Example (Multiplexed Address and Data Bus) | 61 |
| Figure 13. | Intel™ Bus Mode Write Timing Example (Multiplexed Address and Data Bus) | 62 |
| Figure 14. | Motorola Bus Mode Signal and Pin Mapping | 63 |
| Figure 15. | Motorola Bus Mode Read Timing Example | 65 |
| Figure 16. | Motorola Bus Mode Write Timing Example | 66 |
| Figure 17. | Watch-Dog Timer Block Diagram | 71 |
| Figure 18. | Programmable Reload Timer Block Diagram | 75 |
| Figure 19. | PRT Single Pass Mode Operation Example | 77 |
| Figure 20. | PRT Continuous Mode Operation Example | 78 |
| Figure 21. | PRT Timer Output Operation Example | 80 |
| Figure 22. | Real-Time Clock and 32KHz Oscillator Block Diagram | 86 |
| Figure 23. | UART Block Diagram | 102 |
| Figure 24. | Infrared System Block Diagram | 120 |
| Figure 25. | Infrared Data Transmission | 121 |
| Figure 26. | Infrared Data Reception | 122 |
| Figure 27. | SPI Master Device | 125 |
| Figure 28. | SPI Slave Device | 125 |
| Figure 29. | SPI Timing | 127 |
| Figure 30. | I ² C Clock and Data Relationship | 136 |
| Figure 31. | START and STOP Conditions In I ² C Protocol | 136 |
| Figure 32. | I ² C Frame Structure | 137 |



| | |
|--|-----|
| Figure 33. I ² C Acknowledge | 138 |
| Figure 34. Clock Synchronization In I ² C Protocol | 139 |
| Figure 35. Typical ZDI Debug Setup | 156 |
| Figure 36. Schematic For Building a Target Board ZPAKII Connector | 157 |
| Figure 37. ZDI Write Timing | 159 |
| Figure 38. ZDI Read Timing | 159 |
| Figure 39. ZDI Address Write Timing | 160 |
| Figure 40. ZDI Single-Byte Data Write Timing | 161 |
| Figure 41. ZDI Block Data Write Timing | 162 |
| Figure 42. ZDI Single-Byte Data Read Timing | 162 |
| Figure 43. ZDI Block Data Read Timing | 163 |
| Figure 44. Recommended Crystal Oscillator Configuration (20MHz operation) | 196 |
| Figure 45. Recommended Crystal Oscillator Configuration (50MHz operation) | 198 |
| Figure 46. Recommended Crystal Oscillator Configuration (32KHz operation) | 199 |
| Figure 47. I _{CC} vs. Frequency (Typical @ 3.3V, 25°C) | 203 |
| Figure 48. I _{CC} vs. WAIT (Typical @ 3.3V, 25°C) | 203 |
| Figure 49. External Memory Read Timing | 205 |
| Figure 50. External Memory Write Timing | 206 |
| Figure 51. External I/O Read Timing | 208 |
| Figure 52. External I/O Write Timing | 209 |
| Figure 53. Wait State Timing for Read Operations | 211 |
| Figure 54. Wait State Timing for Write Operations | 212 |
| Figure 55. Port Input Sample Timing | 213 |
| Figure 56. GPIO Port Output Timing | 213 |
| Figure 57. 100-Lead Plastic Low-Profile Quad Flat Package (LQFP) | 215 |



List of Tables

| | |
|--|----|
| Table 1. 100-Pin LQFP Pin Identification of the eZ80L92 Device | 5 |
| Table 2. Pin Characteristics of the eZ80L92 | 20 |
| Table 3. Register Map | 25 |
| Table 4. Clock Peripheral Power-Down Register 1 | 37 |
| Table 5. Clock Peripheral Power-Down Register 2 | 38 |
| Table 6. GPIO Mode Selection. | 40 |
| Table 7. Port x Data Registers | 43 |
| Table 8. Port x Data Direction Registers | 44 |
| Table 9. Port x Alternate Registers 1 | 44 |
| Table 10. Port x Alternate Registers 2 | 44 |
| Table 11. Interrupt Vector Sources by Priority | 45 |
| Table 12. Vectored Interrupt Operation | 46 |
| Table 13. Register Values for Memory Chip Select Example | 50 |
| Table 14. Z80 Bus Mode Read States | 53 |
| Table 15. Z80 Bus Mode Write States | 54 |
| Table 16. Intel™ Bus Mode Read States (Separate Address and Data Buses) | 56 |
| Table 17. Intel™ Bus Mode Write States (Separate Address and Data Buses) | 57 |
| Table 18. Intel™ Bus Mode Write States (Multiplexed Address and Data Bus). | 60 |
| Table 19. Intel™ Bus Mode Read States (Multiplexed Address and Data Bus) | 60 |
| Table 20. Motorola Bus Mode Read States | 63 |
| Table 21. Motorola Bus Mode Write States | 64 |
| Table 22. Chip Select x Lower Bound Registers | 67 |
| Table 23. Chip Select x Upper Bound Registers | 67 |
| Table 24. Chip Select x Control Registers | 68 |
| Table 25. Chip Select x Bus Mode Control Registers | 69 |
| Table 26. Watch-Dog Timer Approximate Time-Out Delays | 72 |
| Table 27. Watch-Dog Timer Control Register | 73 |
| Table 28. Watch-Dog Timer Reset Register | 74 |
| Table 29. PRT Single Pass Mode Operation Example | 77 |
| Table 30. PRT Continuous Mode Operation Example | 78 |
| Table 31. PRT Timer Out Operation Example | 80 |
| Table 32. Timer Control Registers | 81 |
| Table 33. Timer Data Registers—Low Byte | 82 |
| Table 34. Timer Data Registers—High Byte | 83 |
| Table 35. Timer Reload Registers—Low Byte | 83 |



| | |
|---|-----|
| Table 36. Timer Reload Registers—High Byte | 84 |
| Table 37. Timer Input Source Select Register | 84 |
| Table 38. Real-Time Clock Seconds Register | 88 |
| Table 39. Real-Time Clock Minutes Register | 89 |
| Table 40. Real-Time Clock Hours Register | 90 |
| Table 41. Real-Time Clock Day-of-the-Week Register | 91 |
| Table 42. Real-Time Clock Day-of-the-Month Register | 92 |
| Table 43. Real-Time Clock Month Register | 93 |
| Table 44. Real-Time Clock Year Register | 94 |
| Table 45. Real-Time Clock Century Register | 95 |
| Table 46. Real-Time Clock Alarm Seconds Register | 96 |
| Table 47. Real-Time Clock Alarm Minutes Register | 97 |
| Table 48. Real-Time Clock Alarm Hours Register | 98 |
| Table 49. Real-Time Clock Alarm Day-of-the-Week Register | 99 |
| Table 50. Real-Time Clock Alarm Control Register | 100 |
| Table 51. Real-Time Clock Control Register | 101 |
| Table 52. UART Baud Rate Generator Registers—Low Byte | 108 |
| Table 53. UART Baud Rate Generator Registers—High Byte | 108 |
| Table 54. UART Transmit Holding Registers | 109 |
| Table 55. UART Receive Buffer Registers | 110 |
| Table 56. UART Interrupt Enable Registers | 110 |
| Table 57. UART Interrupt Identification Registers | 111 |
| Table 58. UART Interrupt Status Codes | 112 |
| Table 59. UART FIFO Control Registers | 112 |
| Table 60. UART Line Control Registers | 113 |
| Table 61. UART Character Parameter Definition | 114 |
| Table 62. UART Modem Control Registers | 115 |
| Table 63. UART Line Status Registers | 116 |
| Table 64. UART Modem Status Registers | 118 |
| Table 65. UART Scratch Pad Registers | 119 |
| Table 66. GPIO Mode Selection when using the IrDA Encoder/Decoder | 123 |
| Table 67. Infrared Encoder/Decoder Control Register | 124 |
| Table 68. SPI Clock Phase (CPHA) and Clock Polarity Operation | 127 |
| Table 69. SPI Baud Rate Generator Register—High Byte | 131 |
| Table 70. SPI Baud Rate Generator Register—Low Byte | 131 |
| Table 71. SPI Control Register | 132 |
| Table 72. SPI Status Register | 133 |
| Table 73. SPI Receive Buffer Register | 134 |



| | |
|--|-----|
| Table 74. SPI Transmit Shift Register | 134 |
| Table 75. I ² C Master Transmit Status Codes. | 141 |
| Table 76. I ² C 10-Bit Master Transmit Status Codes | 142 |
| Table 77. I ² C Master Transmit Status Codes For Data Bytes | 143 |
| Table 78. I ² C Master Receive Status Codes | 144 |
| Table 79. I ² C Master Receive Status Codes For Data Bytes. | 145 |
| Table 80. I ² C Register Descriptions | 147 |
| Table 81. I ² C Slave Address Register | 148 |
| Table 82. I ² C Extended Slave Address Register | 149 |
| Table 83. I ² C Data Register | 149 |
| Table 84. I ² C Control Registers | 151 |
| Table 85. I ² C Status Registers. | 152 |
| Table 86. I ² C Status Codes | 152 |
| Table 87. I ² C Clock Control Registers | 154 |
| Table 88. I ² C Software Reset Register | 155 |
| Table 89. Recommended ZDI Clock vs. System Clock Frequency | 157 |
| Table 90. ZDI Write-Only Registers | 164 |
| Table 91. ZDI Read-Only Registers | 166 |
| Table 92. ZDI Address Match Registers | 167 |
| Table 93. ZDI BREAK Control Register | 168 |
| Table 94. ZDI Master Control Register. | 170 |
| Table 95. ZDI Write Data Registers | 171 |
| Table 96. ZDI Read/Write Control Register Functions. | 172 |
| Table 97. ZDI Bus Control Register | 173 |
| Table 98. Instruction Store 4:0 Registers. | 175 |
| Table 99. ZDI Write Memory Register | 176 |
| Table 100. eZ80 [®] Product ID Low Byte Register. | 176 |
| Table 101. eZ80 [®] Product ID Revision Register | 177 |
| Table 102. eZ80 [®] Product ID High Byte Register | 177 |
| Table 103. ZDI Status Register | 178 |
| Table 104. ZDI Read Registers—Low, High and Upper | 179 |
| Table 105. ZDI Bus Control Register | 180 |
| Table 106. ZDI Read Memory Register | 181 |
| Table 107. OCI Pins | 183 |
| Table 108. Arithmetic Instructions | 185 |
| Table 109. Bit Manipulation Instructions | 185 |
| Table 110. Block Transfer and Compare Instructions | 185 |
| Table 111. Exchange Instructions | 186 |



| | |
|---|-----|
| Table 112. Input/Output Instructions | 186 |
| Table 113. Load Instructions | 187 |
| Table 114. Logical Instructions. | 187 |
| Table 115. Processor Control Instructions | 187 |
| Table 116. Program Control Instructions | 188 |
| Table 117. Rotate and Shift Instructions | 188 |
| Table 118. Op Code Map—First Op Code | 189 |
| Table 119. Op Code Map—Second Op Code after 0CBh | 190 |
| Table 120. Op Code Map—Second Op Code After 0DDh | 191 |
| Table 121. Op Code Map—Second Op Code After 0EDh | 192 |
| Table 122. Op Code Map—Second Op Code After 0FDh | 193 |
| Table 123. Op Code Map—Fourth Byte After 0DDh, 0CBh, and dd | 194 |
| Table 124. Op Code Map—Fourth Byte After 0FDh, 0CBh, and dd* | 195 |
| Table 125. Recommended Crystal Oscillator Specifications (20MHz Operation) | 197 |
| Table 126. Recommended Crystal Oscillator Specifications (50MHz Operation) | 198 |
| Table 127. Recommended Crystal Oscillator Specifications (32KHz Operation) | 199 |
| Table 128. Absolute Maximum Ratings | 201 |
| Table 129. DC Characteristics | 202 |
| Table 130. AC Characteristics | 204 |
| Table 131. External Read Timing. | 205 |
| Table 132. External Write Timing. | 207 |
| Table 133. External I/O Read Timing. | 208 |
| Table 134. External I/O Write Timing | 210 |
| Table 135. GPIO Port Output Timing | 214 |
| Table 136. Bus Acknowledge Timing. | 214 |
| Table 137. PHI System Clock Timing. | 214 |
| Table 138. Ordering Information | 216 |



Architectural Overview

The eZ80L92 microprocessor is a high-speed single-cycle instruction-fetch microprocessor with a maximum clock speed of 50MHz. The eZ80L92 is a member of ZiLOG's new eZ80[®] product family. It can operate in Z80-compatible addressing mode (64KB) or full 24-bit addressing mode (16MB). The rich peripheral set of the eZ80L92 makes it suitable for a variety of applications including industrial control, embedded communication, and point-of-sale terminals.

Features

- Single-cycle instruction fetch, high-performance, pipelined eZ80[®] CPU core¹
- Low power features including SLEEP mode, HALT mode, and selective peripheral power-down control
- Two UARTs with independent baud rate generators
- SPI with independent clock rate generator
- I²C with independent clock rate generator
- Infrared Data Association (IrDA)-compliant infrared encoder/decoder
- New DMA-like eZ80[®] instructions for efficient block data transfer
- Glueless external peripheral interface with 4 Chip Selects, individual Wait State generators, and an external WAIT input pin—supports Intel-and Motorola-style buses
- Fixed-priority vectored interrupts (both internal and external) and interrupt controller
- Real-time clock with on-chip 32KHz oscillator, selectable 50/60Hz input, and separate V_{DD} pin for battery backup
- Six 16-bit Counter/Timers with prescalers and direct input/output drive
- Watch-Dog Timer
- 24 bits of General-Purpose I/O
- JTAG and ZDI debug interfaces
- 100-pin LQFP package
- 3.0–3.6V supply voltage with 5V tolerant inputs

1. For simplicity, the term eZ80[®] CPU is referred to as CPU for the bulk of this document.



- Operating Temperature Range
 - Standard: 0°C to +70°C
 - Extended: –40°C to +105°C

► **Note:** All signals with an overline are active Low. For example, $\overline{B/W}$, for which WORD is active Low, and $\overline{B/W}$, for which BYTE is active Low.

Power connections follow these conventional descriptions:

| Connection | Circuit | Device |
|------------|----------|----------|
| Power | V_{CC} | V_{DD} |
| Ground | GND | V_{SS} |

Block Diagram

Figure 1 illustrates a block diagram of the eZ80L92 microprocessor.

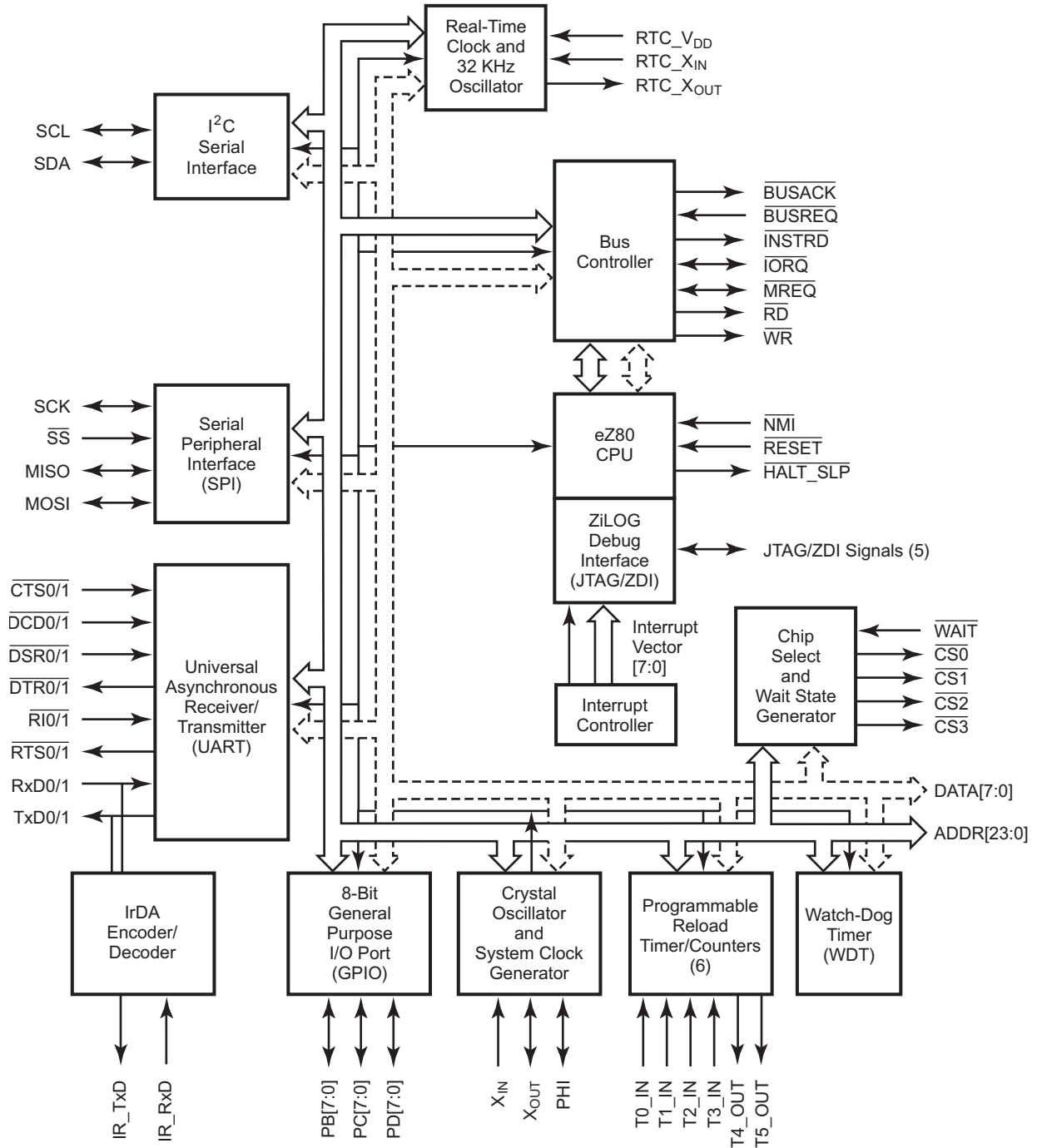

Figure 1. eZ80L92 Block Diagram



Pin Description

Figure 2 illustrates the pin layout of the eZ80L92 in the 100-pin LQFP package. Table 1 describes the pins and their functions.

| | PHI | SCL | SDA | V _{SS} | V _{DD} | PB7/MOSI | PB6/MISO | PB5/T5_OUT | PB4/T4_OUT | PB3/SCK | PB2/SS | PB1/T1_IN | PB0/T0_IN | V _{DD} | X _{OUT} | X _{IN} | V _{SS} | PC7/RI1 | PC6/DCD1 | PC5/DSR1 | PC4/DTR1 | PC3/CTS1 | PC2/RTS1 | PC1/RxD1 | PC0/TxD1 | | | |
|-----------------|-----|-----------------|-----|-----------------|-----------------|----------|----------|------------|------------|---------|--------|-----------|-----------|-----------------|------------------|-----------------|-----------------|---------|----------|----------|----------|----------|----------|----------|----------|----|---------|---------------------|
| ADDR0 | 100 | 99 | 98 | 97 | 96 | 95 | 94 | 93 | 92 | 91 | 90 | 89 | 88 | 87 | 86 | 85 | 84 | 83 | 82 | 81 | 80 | 79 | 78 | 77 | 76 | 75 | PD7/RI0 | |
| ADDR1 | | | | | | | | | | | | | | | | | | | | | | | | | | | 74 | PD6/DCD0 |
| ADDR2 | | | | | | | | | | | | | | | | | | | | | | | | | | | 73 | PD5/DSR0 |
| ADDR3 | | | | | | | | | | | | | | | | | | | | | | | | | | | 72 | PD4/DTR0 |
| ADDR4 | | | | | | | | | | | | | | | | | | | | | | | | | | | 71 | PD3/CTS0 |
| ADDR5 | | | | | | | | | | | | | | | | | | | | | | | | | | | 70 | PD2/RTS0 |
| V _{DD} | | | | | | | | | | | | | | | | | | | | | | | | | | | 69 | PD1/RxD0/IR_RXD |
| V _{SS} | | | | | | | | | | | | | | | | | | | | | | | | | | | 68 | PD0/TxD0/IR_TXD |
| ADDR6 | | | | | | | | | | | | | | | | | | | | | | | | | | | 67 | V _{DD} |
| ADDR7 | | | | | | | | | | | | | | | | | | | | | | | | | | | 66 | TDO |
| ADDR8 | | | | | | | | | | | | | | | | | | | | | | | | | | | 65 | TDI |
| ADDR9 | | | | | | | | | | | | | | | | | | | | | | | | | | | 64 | TRIGOUT |
| ADDR10 | | | | | | | | | | | | | | | | | | | | | | | | | | | 63 | TCK |
| ADDR11 | | | | | | | | | | | | | | | | | | | | | | | | | | | 62 | TMS |
| ADDR12 | | | | | | | | | | | | | | | | | | | | | | | | | | | 61 | V _{SS} |
| ADDR13 | | | | | | | | | | | | | | | | | | | | | | | | | | | 60 | RTC_V _{DD} |
| ADDR14 | | | | | | | | | | | | | | | | | | | | | | | | | | | 59 | RTC_XOUT |
| V _{DD} | | | | | | | | | | | | | | | | | | | | | | | | | | | 58 | RTC_XIN |
| V _{SS} | | | | | | | | | | | | | | | | | | | | | | | | | | | 57 | V _{SS} |
| ADDR15 | | | | | | | | | | | | | | | | | | | | | | | | | | | 56 | V _{DD} |
| ADDR16 | | | | | | | | | | | | | | | | | | | | | | | | | | | 55 | HALT_SLP |
| ADDR17 | | | | | | | | | | | | | | | | | | | | | | | | | | | 54 | BUSACK |
| ADDR18 | | | | | | | | | | | | | | | | | | | | | | | | | | | 53 | BUSREQ |
| ADDR19 | | | | | | | | | | | | | | | | | | | | | | | | | | | 52 | NMI |
| ADDR20 | | | | | | | | | | | | | | | | | | | | | | | | | | | 51 | RESET |
| ADDR21 | 26 | | | | | | | | | | | | | | | | | | | | | | | | | | | |
| ADDR22 | 27 | | | | | | | | | | | | | | | | | | | | | | | | | | | |
| ADDR23 | 28 | | | | | | | | | | | | | | | | | | | | | | | | | | | |
| | 29 | CS0 | | | | | | | | | | | | | | | | | | | | | | | | | | |
| | 30 | CS1 | | | | | | | | | | | | | | | | | | | | | | | | | | |
| | 31 | CS2 | | | | | | | | | | | | | | | | | | | | | | | | | | |
| | 32 | CS3 | | | | | | | | | | | | | | | | | | | | | | | | | | |
| | 33 | V _{DD} | | | | | | | | | | | | | | | | | | | | | | | | | | |
| | 34 | V _{SS} | | | | | | | | | | | | | | | | | | | | | | | | | | |
| | 35 | DATA0 | | | | | | | | | | | | | | | | | | | | | | | | | | |
| | 36 | DATA1 | | | | | | | | | | | | | | | | | | | | | | | | | | |
| | 37 | DATA2 | | | | | | | | | | | | | | | | | | | | | | | | | | |
| | 38 | DATA3 | | | | | | | | | | | | | | | | | | | | | | | | | | |
| | 39 | DATA4 | | | | | | | | | | | | | | | | | | | | | | | | | | |
| | 40 | DATA5 | | | | | | | | | | | | | | | | | | | | | | | | | | |
| | 41 | DATA6 | | | | | | | | | | | | | | | | | | | | | | | | | | |
| | 42 | DATA7 | | | | | | | | | | | | | | | | | | | | | | | | | | |
| | 43 | V _{DD} | | | | | | | | | | | | | | | | | | | | | | | | | | |
| | 44 | V _{SS} | | | | | | | | | | | | | | | | | | | | | | | | | | |
| | 45 | IORQ | | | | | | | | | | | | | | | | | | | | | | | | | | |
| | 46 | MREQ | | | | | | | | | | | | | | | | | | | | | | | | | | |
| | 47 | RD | | | | | | | | | | | | | | | | | | | | | | | | | | |
| | 48 | WR | | | | | | | | | | | | | | | | | | | | | | | | | | |
| | 49 | INSTRD | | | | | | | | | | | | | | | | | | | | | | | | | | |
| | 50 | WAIT | | | | | | | | | | | | | | | | | | | | | | | | | | |

Figure 2. 100-Pin LQFP Configuration of the eZ80L92



Table 1. 100-Pin LQFP Pin Identification of the eZ80L92 Device

| Pin # | Symbol | Function | Signal Direction | Description |
|-------|--------|-------------|------------------|---|
| 1 | ADDR0 | Address Bus | Bidirectional | Configured as an output in normal operation. The address bus selects a location in memory or I/O space to be read or written. Configured as an input during bus acknowledge cycles. Drives the Chip Select/Wait State Generator block to generate Chip Selects. |
| 2 | ADDR1 | Address Bus | Bidirectional | Configured as an output in normal operation. The address bus selects a location in memory or I/O space to be read or written. Configured as an input during bus acknowledge cycles. Drives the Chip Select/Wait State Generator block to generate Chip Selects. |
| 3 | ADDR2 | Address Bus | Bidirectional | Configured as an output in normal operation. The address bus selects a location in memory or I/O space to be read or written. Configured as an input during bus acknowledge cycles. Drives the Chip Select/Wait State Generator block to generate Chip Selects. |
| 4 | ADDR3 | Address Bus | Bidirectional | Configured as an output in normal operation. The address bus selects a location in memory or I/O space to be read or written. Configured as an input during bus acknowledge cycles. Drives the Chip Select/Wait State Generator block to generate Chip Selects. |
| 5 | ADDR4 | Address Bus | Bidirectional | Configured as an output in normal operation. The address bus selects a location in memory or I/O space to be read or written. Configured as an input during bus acknowledge cycles. Drives the Chip Select/Wait State Generator block to generate Chip Selects. |
| 6 | ADDR5 | Address Bus | Bidirectional | Configured as an output in normal operation. The address bus selects a location in memory or I/O space to be read or written. Configured as an input during bus acknowledge cycles. Drives the Chip Select/Wait State Generator block to generate Chip Selects. |



Table 1. 100-Pin LQFP Pin Identification of the eZ80L92 Device (Continued)

| Pin # | Symbol | Function | Signal Direction | Description |
|-------|-----------------|--------------|------------------|---|
| 7 | V _{DD} | Power Supply | | Power Supply. |
| 8 | V _{SS} | Ground | | Ground. |
| 9 | ADDR6 | Address Bus | Bidirectional | Configured as an output in normal operation. The address bus selects a location in memory or I/O space to be read or written. Configured as an input during bus acknowledge cycles. Drives the Chip Select/Wait State Generator block to generate Chip Selects. |
| 10 | ADDR7 | Address Bus | Bidirectional | Configured as an output in normal operation. The address bus selects a location in memory or I/O space to be read or written. Configured as an input during bus acknowledge cycles. Drives the Chip Select/Wait State Generator block to generate Chip Selects. |
| 11 | ADDR8 | Address Bus | Bidirectional | Configured as an output in normal operation. The address bus selects a location in memory or I/O space to be read or written. Configured as an input during bus acknowledge cycles. Drives the Chip Select/Wait State Generator block to generate Chip Selects. |
| 12 | ADDR9 | Address Bus | Bidirectional | Configured as an output in normal operation. The address bus selects a location in memory or I/O space to be read or written. Configured as an input during bus acknowledge cycles. Drives the Chip Select/Wait State Generator block to generate Chip Selects. |
| 13 | ADDR10 | Address Bus | Bidirectional | Configured as an output in normal operation. The address bus selects a location in memory or I/O space to be read or written. Configured as an input during bus acknowledge cycles. Drives the Chip Select/Wait State Generator block to generate Chip Selects. |



Table 1. 100-Pin LQFP Pin Identification of the eZ80L92 Device (Continued)

| Pin # | Symbol | Function | Signal Direction | Description |
|-------|-----------------|--------------|------------------|---|
| 14 | ADDR11 | Address Bus | Bidirectional | Configured as an output in normal operation. The address bus selects a location in memory or I/O space to be read or written. Configured as an input during bus acknowledge cycles. Drives the Chip Select/Wait State Generator block to generate Chip Selects. |
| 15 | ADDR12 | Address Bus | Bidirectional | Configured as an output in normal operation. The address bus selects a location in memory or I/O space to be read or written. Configured as an input during bus acknowledge cycles. Drives the Chip Select/Wait State Generator block to generate Chip Selects. |
| 16 | ADDR13 | Address Bus | Bidirectional | Configured as an output in normal operation. The address bus selects a location in memory or I/O space to be read or written. Configured as an input during bus acknowledge cycles. Drives the Chip Select/Wait State Generator block to generate Chip Selects. |
| 17 | ADDR14 | Address Bus | Bidirectional | Configured as an output in normal operation. The address bus selects a location in memory or I/O space to be read or written. Configured as an input during bus acknowledge cycles. Drives the Chip Select/Wait State Generator block to generate Chip Selects. |
| 18 | V _{DD} | Power Supply | | Power Supply. |
| 19 | V _{SS} | Ground | | Ground. |
| 20 | ADDR15 | Address Bus | Bidirectional | Configured as an output in normal operation. The address bus selects a location in memory or I/O space to be read or written. Configured as an input during bus acknowledge cycles. Drives the Chip Select/Wait State Generator block to generate Chip Selects. |



Table 1. 100-Pin LQFP Pin Identification of the eZ80L92 Device (Continued)

| Pin # | Symbol | Function | Signal Direction | Description |
|-------|--------|-------------|------------------|---|
| 21 | ADDR16 | Address Bus | Bidirectional | Configured as an output in normal operation. The address bus selects a location in memory or I/O space to be read or written. Configured as an input during bus acknowledge cycles. Drives the Chip Select/Wait State Generator block to generate Chip Selects. |
| 22 | ADDR17 | Address Bus | Bidirectional | Configured as an output in normal operation. The address bus selects a location in memory or I/O space to be read or written. Configured as an input during bus acknowledge cycles. Drives the Chip Select/Wait State Generator block to generate Chip Selects. |
| 23 | ADDR18 | Address Bus | Bidirectional | Configured as an output in normal operation. The address bus selects a location in memory or I/O space to be read or written. Configured as an input during bus acknowledge cycles. Drives the Chip Select/Wait State Generator block to generate Chip Selects. |
| 24 | ADDR19 | Address Bus | Bidirectional | Configured as an output in normal operation. The address bus selects a location in memory or I/O space to be read or written. Configured as an input during bus acknowledge cycles. Drives the Chip Select/Wait State Generator block to generate Chip Selects. |
| 25 | ADDR20 | Address Bus | Bidirectional | Configured as an output in normal operation. The address bus selects a location in memory or I/O space to be read or written. Configured as an input during bus acknowledge cycles. Drives the Chip Select/Wait State Generator block to generate Chip Selects. |
| 26 | ADDR21 | Address Bus | Bidirectional | Configured as an output in normal operation. The address bus selects a location in memory or I/O space to be read or written. Configured as an input during bus acknowledge cycles. Drives the Chip Select/Wait State Generator block to generate Chip Selects. |



Table 1. 100-Pin LQFP Pin Identification of the eZ80L92 Device (Continued)

| Pin # | Symbol | Function | Signal Direction | Description |
|-------|-------------------------|---------------|--------------------|---|
| 27 | ADDR22 | Address Bus | Bidirectional | Configured as an output in normal operation. The address bus selects a location in memory or I/O space to be read or written. Configured as an input during bus acknowledge cycles. Drives the Chip Select/Wait State Generator block to generate Chip Selects. |
| 28 | ADDR23 | Address Bus | Bidirectional | Configured as an output in normal operation. The address bus selects a location in memory or I/O space to be read or written. Configured as an input during bus acknowledge cycles. Drives the Chip Select/Wait State Generator block to generate Chip Selects. |
| 29 | $\overline{\text{CS0}}$ | Chip Select 0 | Output, Active Low | $\overline{\text{CS0}}$ Low indicates <u>that</u> an access is occurring in the defined CS0 memory or I/O address space. |
| 30 | $\overline{\text{CS1}}$ | Chip Select 1 | Output, Active Low | $\overline{\text{CS1}}$ Low indicates <u>that</u> an access is occurring in the defined CS1 memory or I/O address space. |
| 31 | $\overline{\text{CS2}}$ | Chip Select 2 | Output, Active Low | $\overline{\text{CS2}}$ Low indicates <u>that</u> an access is occurring in the defined CS2 memory or I/O address space. |
| 32 | $\overline{\text{CS3}}$ | Chip Select 3 | Output, Active Low | $\overline{\text{CS3}}$ Low indicates <u>that</u> an access is occurring in the defined CS3 memory or I/O address space. |
| 33 | V_{DD} | Power Supply | | Power Supply. |
| 34 | V_{SS} | Ground | | Ground. |
| 35 | DATA0 | Data Bus | Bidirectional | The data bus transfers data to and from I/O and memory devices. The eZ80L92 drives these lines only during write cycles when the eZ80L92 is the bus master. |
| 36 | DATA1 | Data Bus | Bidirectional | The data bus transfers data to and from I/O and memory devices. The eZ80L92 drives these lines only during write cycles when the eZ80L92 is the bus master. |



Table 1. 100-Pin LQFP Pin Identification of the eZ80L92 Device (Continued)

| Pin # | Symbol | Function | Signal Direction | Description |
|-------|--------------------------|----------------------|---------------------------|--|
| 37 | DATA2 | Data Bus | Bidirectional | The data bus transfers data to and from I/O and memory devices. The eZ80L92 drives these lines only during write cycles when the eZ80L92 is the bus master. |
| 38 | DATA3 | Data Bus | Bidirectional | The data bus transfers data to and from I/O and memory devices. The eZ80L92 drives these lines only during write cycles when the eZ80L92 is the bus master. |
| 39 | DATA4 | Data Bus | Bidirectional | The data bus transfers data to and from I/O and memory devices. The eZ80L92 drives these lines only during write cycles when the eZ80L92 is the bus master. |
| 40 | DATA5 | Data Bus | Bidirectional | The data bus transfers data to and from I/O and memory devices. The eZ80L92 drives these lines only during write cycles when the eZ80L92 is the bus master. |
| 41 | DATA6 | Data Bus | Bidirectional | The data bus transfers data to and from I/O and memory devices. The eZ80L92 drives these lines only during write cycles when the eZ80L92 is the bus master. |
| 42 | DATA7 | Data Bus | Bidirectional | The data bus transfers data to and from I/O and memory devices. The eZ80L92 drives these lines only during write cycles when the eZ80L92 is the bus master. |
| 43 | V _{DD} | Power Supply | | Power Supply. |
| 44 | V _{SS} | Ground | | Ground. |
| 45 | $\overline{\text{IORQ}}$ | Input/Output Request | Bidirectional, Active Low | $\overline{\text{IORQ}}$ indicates that the CPU is <u>accessing</u> a location in I/O space. RD and WR indicate the type of access. The eZ80L92 does not drive this line during RESET. It is an input in bus acknowledge cycles. |
| 46 | $\overline{\text{MREQ}}$ | Memory Request | Bidirectional, Active Low | $\overline{\text{MREQ}}$ Low indicates that the CPU is <u>accessing a location</u> in memory. The RD, WR, and INSTRD signals indicate the type of access. The eZ80L92 does not drive this line during RESET. It is an input in bus acknowledge cycles. |



Table 1. 100-Pin LQFP Pin Identification of the eZ80L92 Device (Continued)

| Pin # | Symbol | Function | Signal Direction | Description |
|-------|-------------------------------|----------------------------|-----------------------------------|---|
| 47 | $\overline{\text{RD}}$ | Read | Output, Active Low | $\overline{\text{RD}}$ Low indicates that the eZ80L92 is reading from the current address location. This pin is tristated during bus acknowledge cycles. |
| 48 | $\overline{\text{WR}}$ | Write | Output, Active Low | $\overline{\text{WR}}$ indicates that the CPU is writing to the current address location. This pin is tristated during bus acknowledge cycles. |
| 49 | $\overline{\text{INSTRD}}$ | Instruction Read Indicator | Output, Active Low | $\overline{\text{INSTRD}}$ (with $\overline{\text{MREQ}}$ and $\overline{\text{RD}}$) indicates the eZ80L92 is fetching an instruction from memory. This pin is tristated during bus acknowledge cycles. |
| 50 | $\overline{\text{WAIT}}$ | WAIT Request | Input, Active Low | Driving the $\overline{\text{WAIT}}$ pin Low forces the CPU to wait additional clock cycles for an external peripheral or external memory to complete its Read or Write operation. |
| 51 | $\overline{\text{RESET}}$ | Reset | Schmitt Trigger Input, Active Low | This signal is used to initialize the eZ80L92. This input must be Low for a minimum of 3 system clock cycles, and must be held Low until the clock is stable. This input includes a Schmitt trigger to allow RC rise times. |
| 52 | $\overline{\text{NMI}}$ | Nonmaskable Interrupt | Schmitt Trigger Input, Active Low | The $\overline{\text{NMI}}$ input is a higher priority input than the maskable interrupts. It is always recognized at the end of an instruction, regardless of the state of the interrupt enable control bits. This input includes a Schmitt trigger to allow RC rise times. |
| 53 | $\overline{\text{BUSREQ}}$ | Bus Request | Input, Active Low | External devices can request the eZ80L92 to release the memory interface bus for their use, by driving this pin Low. |
| 54 | $\overline{\text{BUSACK}}$ | Bus Acknowledge | Output, Active Low | The eZ80L92 responds to a Low on $\overline{\text{BUSREQ}}$, by tristating the address, data, and control signals, and by driving the $\overline{\text{BUSACK}}$ line Low. During bus acknowledge cycles $\text{ADDR}[23:0]$, IORQ , and MREQ are inputs. |
| 55 | $\overline{\text{HALT_SLP}}$ | HALT and SLEEP Indicator | Output, Active Low | A Low on this pin indicates that the CPU has entered either HALT or SLEEP mode because of execution of either a HALT or SLP instruction. |



Table 1. 100-Pin LQFP Pin Identification of the eZ80L92 Device (Continued)

| Pin # | Symbol | Function | Signal Direction | Description |
|-------|---------------------|--------------------------------|------------------|---|
| 56 | V _{DD} | Power Supply | | Power Supply. |
| 57 | V _{SS} | Ground | | Ground. |
| 58 | RTC_XIN | Real-Time Clock Crystal Input | Input | This pin is the input to the low-power 32KHz crystal oscillator for the Real-Time Clock. |
| 59 | RTC_XOUT | Real-Time Clock Crystal Output | Bidirectional | This pin is the output from the low-power 32KHz crystal oscillator for the Real-Time Clock. This pin is an input when the RTC is configured to operate from 50/60Hz input clock signals and the 32KHz crystal oscillator is disabled. |
| 60 | RTC_V _{DD} | Real-Time Clock Power Supply | | Power supply for the Real-Time Clock and associated 32KHz oscillator. Isolated from the power supply to the remainder of the chip. A battery can be connected to this pin to supply constant power to the Real-Time Clock and 32KHz oscillator. |
| 61 | V _{SS} | Ground | | Ground. |
| 62 | TMS | JTAG Test Mode Select | Input | JTAG Mode Select Input. |
| 63 | TCK | JTAG Test Clock | Input | JTAG and ZDI clock input. |
| 64 | TRIGOUT | JTAG Test Trigger Output | Output | Active High trigger event indicator. |
| 65 | TDI | JTAG Test Data In | Bidirectional | JTAG data input pin. Functions as ZDI data I/O pin when JTAG is disabled. |
| 66 | TDO | JTAG Test Data Out | Output | JTAG data output pin. |
| 67 | V _{DD} | Power Supply | | Power Supply. |



Table 1. 100-Pin LQFP Pin Identification of the eZ80L92 Device (Continued)

| Pin # | Symbol | Function | Signal Direction | Description |
|-------|--------|--------------------|--------------------|---|
| 68 | PD0 | GPIO Port D | Bidirectional | This pin can be used for general-purpose I/O. It can be individually programmed as input or output and can also be used individually as an interrupt input. Each Port D pin, when programmed as output, can be selected to be an open-drain or open-source output. Port D is multiplexed with one UART. |
| | TxD0 | UART Transmit Data | Output | This pin is used by the UART to transmit asynchronous serial data. This signal is multiplexed with PD0. |
| | IR_TXD | IrDA Transmit Data | Output | This pin is used by the IrDA encoder/decoder to transmit serial data. This signal is multiplexed with PD0. |
| 69 | PD1 | GPIO Port D | Bidirectional | This pin can be used for general-purpose I/O. It can be individually programmed as input or output and can also be used individually as an interrupt input. Each Port D pin, when programmed as output, can be selected to be an open-drain or open-source output. Port D is multiplexed with one UART. |
| | RxD0 | Receive Data | Input | This pin is used by the UART to receive asynchronous serial data. This signal is multiplexed with PD1. |
| | IR_RXD | IrDA Receive Data | Input | This pin is used by the IrDA encoder/decoder to receive serial data. This signal is multiplexed with PD1. |
| 70 | PD2 | GPIO Port D | Bidirectional | This pin can be used for general-purpose I/O. It can be individually programmed as input or output and can also be used individually as an interrupt input. Each Port D pin, when programmed as output, can be selected to be an open-drain or open-source output. Port D is multiplexed with one UART. |
| | RTS0 | Request to Send | Output, Active Low | Modem control signal from UART. This signal is multiplexed with PD2. |



Table 1. 100-Pin LQFP Pin Identification of the eZ80L92 Device (Continued)

| Pin # | Symbol | Function | Signal Direction | Description |
|-------|--------------------------|---------------------|--------------------|---|
| 71 | PD3 | GPIO Port D | Bidirectional | This pin can be used for general-purpose I/O. It can be individually programmed as input or output and can also be used individually as an interrupt input. Each Port D pin, when programmed as output, can be selected to be an open-drain or open-source output. Port D is multiplexed with one UART. |
| | $\overline{\text{CTS0}}$ | Clear to Send | Input, Active Low | Modem status signal to the UART. This signal is multiplexed with PD3. |
| 72 | PD4 | GPIO Port D | Bidirectional | This pin can be used for general-purpose I/O. It can be individually programmed as input or output and can also be used individually as an interrupt input. Each Port D pin, when programmed as output, can be selected to be an open-drain or open-source output. Port D is multiplexed with one UART. |
| | $\overline{\text{DTR0}}$ | Data Terminal Ready | Output, Active Low | Modem control signal to the UART. This signal is multiplexed with PD4. |
| 73 | PD5 | GPIO Port D | Bidirectional | This pin can be used for general-purpose I/O. It can be individually programmed as input or output and can also be used individually as an interrupt input. Each Port D pin, when programmed as output, can be selected to be an open-drain or open-source output. Port D is multiplexed with one UART. |
| | $\overline{\text{DSR0}}$ | Data Set Ready | Input, Active Low | Modem status signal to the UART. This signal is multiplexed with PD5. |
| 74 | PD6 | GPIO Port D | Bidirectional | This pin can be used for general-purpose I/O. It can be individually programmed as input or output and can also be used individually as an interrupt input. Each Port D pin, when programmed as output, can be selected to be an open-drain or open-source output. Port D is multiplexed with one UART. |
| | $\overline{\text{DCD0}}$ | Data Carrier Detect | Input, Active Low | Modem status signal to the UART. This signal is multiplexed with PD6. |



Table 1. 100-Pin LQFP Pin Identification of the eZ80L92 Device (Continued)

| Pin # | Symbol | Function | Signal Direction | Description |
|-------|-------------------------|----------------|-------------------|---|
| 75 | PD7 | GPIO Port D | Bidirectional | This pin can be used for general-purpose I/O. It can be individually programmed as input or output and can also be used individually as an interrupt input. Each Port D pin, when programmed as output, can be selected to be an open-drain or open-source output. Port D is multiplexed with one UART. |
| | $\overline{\text{RI0}}$ | Ring Indicator | Input, Active Low | Modem status signal to the UART. This signal is multiplexed with PD7. |
| 76 | PC0 | GPIO Port C | Bidirectional | This pin can be used for general-purpose I/O. It can be individually programmed as input or output and can also be used individually as an interrupt input. Each Port C pin, when programmed as output, can be selected to be an open-drain or open-source output. Port C is multiplexed with one UART. |
| | TxD1 | Transmit Data | Output | This pin is used by the UART to transmit asynchronous serial data. This signal is multiplexed with PC0. |
| 77 | PC1 | GPIO Port C | Bidirectional | This pin can be used for general-purpose I/O. It can be individually programmed as input or output and can also be used individually as an interrupt input. Each Port C pin, when programmed as output, can be selected to be an open-drain or open-source output. Port C is multiplexed with one UART. |
| | RxD1 | Receive Data | Input | This pin is used by the UART to receive asynchronous serial data. This signal is multiplexed with PC1. |



Table 1. 100-Pin LQFP Pin Identification of the eZ80L92 Device (Continued)

| Pin # | Symbol | Function | Signal Direction | Description |
|-------|--------|---------------------|--------------------|---|
| 78 | PC2 | GPIO Port C | Bidirectional | This pin can be used for general-purpose I/O. It can be individually programmed as input or output and can also be used individually as an interrupt input. Each Port C pin, when programmed as output, can be selected to be an open-drain or open-source output. Port C is multiplexed with one UART. |
| | RTS1 | Request to Send | Output, Active Low | Modem control signal from UART. This signal is multiplexed with PC2. |
| 79 | PC3 | GPIO Port C | Bidirectional | This pin can be used for general-purpose I/O. It can be individually programmed as input or output and can also be used individually as an interrupt input. Each Port C pin, when programmed as output, can be selected to be an open-drain or open-source output. Port C is multiplexed with one UART. |
| | CTS1 | Clear to Send | Input, Active Low | Modem status signal to the UART. This signal is multiplexed with PC3. |
| 80 | PC4 | GPIO Port C | Bidirectional | This pin can be used for general-purpose I/O. It can be individually programmed as input or output and can also be used individually as an interrupt input. Each Port C pin, when programmed as output, can be selected to be an open-drain or open-source output. Port C is multiplexed with one UART. |
| | DTR1 | Data Terminal Ready | Output, Active Low | Modem control signal to the UART. This signal is multiplexed with PC4. |
| 81 | PC5 | GPIO Port C | Bidirectional | This pin can be used for general-purpose I/O. It can be individually programmed as input or output and can also be used individually as an interrupt input. Each Port C pin, when programmed as output, can be selected to be an open-drain or open-source output. Port C is multiplexed with one UART. |
| | DSR1 | Data Set Ready | Input, Active Low | Modem status signal to the UART. This signal is multiplexed with PC5. |



Table 1. 100-Pin LQFP Pin Identification of the eZ80L92 Device (Continued)

| Pin # | Symbol | Function | Signal Direction | Description |
|-------|--------------------------|--------------------------------|-------------------|---|
| 82 | PC6 | GPIO Port C | Bidirectional | This pin can be used for general-purpose I/O. It can be individually programmed as input or output and can also be used individually as an interrupt input. Each Port C pin, when programmed as output, can be selected to be an open-drain or open-source output. Port C is multiplexed with one UART. |
| | $\overline{\text{DCD1}}$ | Data Carrier Detect | Input, Active Low | Modem status signal to the UART. This signal is multiplexed with PC6. |
| 83 | PC7 | GPIO Port C | Bidirectional | This pin can be used for general-purpose I/O. It can be individually programmed as input or output and can also be used individually as an interrupt input. Each Port C pin, when programmed as output, can be selected to be an open-drain or open-source output. Port C is multiplexed with one UART. |
| | $\overline{\text{RI1}}$ | Ring Indicator | Input, Active Low | Modem status signal to the UART. This signal is multiplexed with PC7. |
| 84 | V_{SS} | Ground | | Ground. |
| 85 | X_{IN} | System Clock Oscillator Input | Input | This pin is the input to the onboard crystal oscillator for the primary system clock. If an external oscillator is used, its clock output should be connected to this pin. When a crystal is used, it should be connected between X_{IN} and X_{OUT} . |
| 86 | X_{OUT} | System Clock Oscillator Output | Output | This pin is the output of the onboard crystal oscillator. When used, a crystal should be connected between X_{IN} and X_{OUT} . |
| 87 | V_{DD} | Power Supply | | Power Supply. |



Table 1. 100-Pin LQFP Pin Identification of the eZ80L92 Device (Continued)

| Pin # | Symbol | Function | Signal Direction | Description |
|-------|------------------------|------------------|-------------------|--|
| 88 | PB0 | GPIO Port B | Bidirectional | This pin can be used for general-purpose I/O. It can be individually programmed as input or output and can also be used individually as an interrupt input. Each Port B pin, when programmed as output, can be selected to be an open-drain or open-source output. |
| | T0_IN | Timer 0 In | Input | Alternate clock source for Programmable Reload Timers 0 and 2. This signal is multiplexed with PB0. |
| 89 | PB1 | GPIO Port B | Bidirectional | This pin can be used for general-purpose I/O. It can be individually programmed as input or output and can also be used individually as an interrupt input. Each Port B pin, when programmed as output, can be selected to be an open-drain or open-source output. |
| | T1_IN | Timer 1 In | Input | Alternate clock source for Programmable Reload Timers 1 and 3. This signal is multiplexed with PB1. |
| 90 | PB2 | GPIO Port B | Bidirectional | This pin can be used for general-purpose I/O. It can be individually programmed as input or output and can also be used individually as an interrupt input. Each Port B pin, when programmed as output, can be selected to be an open-drain or open-source output. |
| | $\overline{\text{SS}}$ | Slave Select | Input, Active Low | The slave select input line is used to select a slave device in SPI mode. This signal is multiplexed with PB2. |
| 91 | PB3 | GPIO Port B | Bidirectional | This pin can be used for general-purpose I/O. It can be individually programmed as input or output and can also be used individually as an interrupt input. Each Port B pin, when programmed as output, can be selected to be an open-drain or open-source output. |
| | SCK | SPI Serial Clock | Bidirectional | SPI serial clock. This signal is multiplexed with PB3. |



Table 1. 100-Pin LQFP Pin Identification of the eZ80L92 Device (Continued)

| Pin # | Symbol | Function | Signal Direction | Description |
|-------|--------|------------------------|------------------|--|
| 92 | PB4 | GPIO Port B | Bidirectional | This pin can be used for general-purpose I/O. It can be individually programmed as input or output and can also be used individually as an interrupt input. Each Port B pin, when programmed as output, can be selected to be an open-drain or open-source output. |
| | T4_OUT | Timer 4 Out | Output | Programmable Reload Timer 4 timer-out signal. This signal is multiplexed with PB4. |
| 93 | PB5 | GPIO Port B | Bidirectional | This pin can be used for general-purpose I/O. It can be individually programmed as input or output and can also be used individually as an interrupt input. Each Port B pin, when programmed as output, can be selected to be an open-drain or open-source output. |
| | T5_OUT | Timer 5 Out | Output | Programmable Reload Timer 5 timer-out signal. This signal is multiplexed with PB5. |
| 94 | PB6 | GPIO Port B | Bidirectional | This pin can be used for general-purpose I/O. It can be individually programmed as input or output and can also be used individually as an interrupt input. Each Port B pin, when programmed as output, can be selected to be an open-drain or open-source output. |
| | MISO | Master In Slave Out | Bidirectional | The MISO line is configured as an input when the eZ80L92 is an SPI master device and as an output when eZ80L92 is an SPI slave device. This signal is multiplexed with PB6. |



Table 1. 100-Pin LQFP Pin Identification of the eZ80L92 Device (Continued)

| Pin # | Symbol | Function | Signal Direction | Description |
|-------|-----------------|-------------------------------|------------------|--|
| 95 | PB7 | GPIO Port B | Bidirectional | This pin can be used for general-purpose I/O. It can be individually programmed as input or output and can also be used individually as an interrupt input. Each Port B pin, when programmed as output, can be selected to be an open-drain or open-source output. |
| | MOSI | Master Out Slave In | Bidirectional | The MOSI line is configured as an output when the eZ80L92 is an SPI master device and as an input when the eZ80L92 is an SPI slave device. This signal is multiplexed with PB7. |
| 96 | V _{DD} | Power Supply | | Power Supply. |
| 97 | V _{SS} | Ground | | Ground. |
| 98 | SDA | I ² C Serial Data | Bidirectional | This pin carries the I ² C data signal. |
| 99 | SCL | I ² C Serial Clock | Bidirectional | This pin is used to receive and transmit the I ² C clock. |
| 100 | PHI | System Clock | Output | This pin is an output driven by the internal system clock. |

Pin Characteristics

Table 2 describes the characteristics of each pin in the eZ80L92's 100-pin LQFP package.

Table 2. Pin Characteristics of the eZ80™ Webserver-i

| Pin # | Symbol | Direction | Reset Direction | Active Low/High | Tristate Output | Pull Up/Down | Schmitt Trigger Input | Open Drain/Source |
|-------|-----------------|-----------|-----------------|-----------------|-----------------|--------------|-----------------------|-------------------|
| 1 | ADDR0 | I/O | O | N/A | Yes | No | No | No |
| 2 | ADDR1 | I/O | O | N/A | Yes | No | No | No |
| 3 | ADDR2 | I/O | O | N/A | Yes | No | No | No |
| 4 | ADDR3 | I/O | O | N/A | Yes | No | No | No |
| 5 | ADDR4 | I/O | O | N/A | Yes | No | No | No |
| 6 | ADDR5 | I/O | O | N/A | Yes | No | No | No |
| 7 | V _{DD} | | | | | | | |



Table 2. Pin Characteristics of the eZ80™ Webserver-i (Continued)

| Pin # | Symbol | Direction | Reset Direction | Active Low/High | Tristate Output | Pull Up/Down | Schmitt Trigger Input | Open Drain/Source |
|-------|------------------|-----------|-----------------|-----------------|-----------------|--------------|-----------------------|-------------------|
| 8 | V_{SS} | | | | | | | |
| 9 | ADDR6 | I/O | O | N/A | Yes | No | No | No |
| 10 | ADDR7 | I/O | O | N/A | Yes | No | No | No |
| 11 | ADDR8 | I/O | O | N/A | Yes | No | No | No |
| 12 | ADDR9 | I/O | O | N/A | Yes | No | No | No |
| 13 | ADDR10 | I/O | O | N/A | Yes | No | No | No |
| 14 | ADDR11 | I/O | O | N/A | Yes | No | No | No |
| 15 | ADDR12 | I/O | O | N/A | Yes | No | No | No |
| 16 | ADDR13 | I/O | O | N/A | Yes | No | No | No |
| 17 | ADDR14 | I/O | O | N/A | Yes | No | No | No |
| 18 | V_{DD} | | | | | | | |
| 19 | V_{SS} | | | | | | | |
| 20 | ADDR15 | I/O | O | N/A | Yes | No | No | No |
| 21 | ADDR16 | I/O | O | N/A | Yes | No | No | No |
| 22 | ADDR17 | I/O | O | N/A | Yes | No | No | No |
| 23 | ADDR18 | I/O | O | N/A | Yes | No | No | No |
| 24 | ADDR19 | I/O | O | N/A | Yes | No | No | No |
| 25 | ADDR20 | I/O | O | N/A | Yes | No | No | No |
| 26 | ADDR21 | I/O | O | N/A | Yes | No | No | No |
| 27 | ADDR22 | I/O | O | N/A | Yes | No | No | No |
| 28 | ADDR23 | I/O | O | N/A | Yes | No | No | No |
| 29 | $\overline{CS0}$ | O | O | Low | No | No | No | No |
| 30 | $\overline{CS1}$ | O | O | Low | No | No | No | No |
| 31 | $\overline{CS2}$ | O | O | Low | No | No | No | No |
| 32 | $\overline{CS3}$ | O | O | Low | No | No | No | No |
| 33 | V_{DD} | | | | | | | |
| 34 | V_{SS} | | | | | | | |
| 35 | DATA0 | I/O | I | N/A | Yes | No | No | No |



Table 2. Pin Characteristics of the eZ80™ Webserver-i (Continued)

| Pin # | Symbol | Direction | Reset Direction | Active Low/High | Tristate Output | Pull Up/Down | Schmitt Trigger Input | Open Drain/Source |
|-------|-------------------------------|-----------|-----------------|-----------------|-----------------|--------------|-----------------------|-------------------|
| 36 | DATA1 | I/O | I | N/A | Yes | No | No | No |
| 37 | DATA2 | I/O | I | N/A | Yes | No | No | No |
| 38 | DATA3 | I/O | I | N/A | Yes | No | No | No |
| 39 | DATA4 | I/O | I | N/A | Yes | No | No | No |
| 40 | DATA5 | I/O | I | N/A | Yes | No | No | No |
| 41 | DATA6 | I/O | I | N/A | Yes | No | No | No |
| 42 | DATA7 | I/O | I | N/A | Yes | No | No | No |
| 43 | V _{DD} | | | | | | | |
| 44 | V _{SS} | | | | | | | |
| 45 | $\overline{\text{IORQ}}$ | I/O | O | Low | Yes | No | No | No |
| 46 | $\overline{\text{MREQ}}$ | I/O | O | Low | Yes | No | No | No |
| 47 | $\overline{\text{RD}}$ | O | O | Low | No | No | No | No |
| 48 | $\overline{\text{WR}}$ | O | O | Low | No | No | No | No |
| 49 | $\overline{\text{INSTRD}}$ | O | O | Low | No | No | No | No |
| 50 | $\overline{\text{WAIT}}$ | I | I | Low | N/A | No | No | N/A |
| 51 | $\overline{\text{RESET}}$ | I | I | Low | N/A | Up | Yes | N/A |
| 52 | $\overline{\text{NMI}}$ | I | I | Low | N/A | No | Yes | N/A |
| 53 | $\overline{\text{BUSREQ}}$ | I | I | Low | N/A | No | No | N/A |
| 54 | $\overline{\text{BUSACK}}$ | O | O | Low | No | No | No | No |
| 55 | $\overline{\text{HALT_SLP}}$ | O | O | Low | No | No | No | No |
| 56 | V _{DD} | | | | | | | |
| 57 | V _{SS} | | | | | | | |
| 58 | RTC_X _{IN} | I | I | N/A | N/A | No | No | N/A |
| 59 | RTC_X _{OUT} | I/O | U | N/A | N/A | No | No | No |
| 60 | RTC_V _{DD} | | | | | | | |
| 61 | V _{SS} | | | | | | | |
| 62 | TMS | I | I | N/A | N/A | Up | No | N/A |



Table 2. Pin Characteristics of the eZ80™ Webserver-i (Continued)

| Pin # | Symbol | Direction | Reset Direction | Active Low/High | Tristate Output | Pull Up/Down | Schmitt Trigger Input | Open Drain/Source |
|-------|------------------|-----------|-----------------|------------------------------|-----------------|--------------|-----------------------|-------------------|
| 63 | TCK | I | I | Rising (In) Falling (Out) | N/A | Up | No | N/A |
| 64 | TRIGOUT | I/O | O | High | Yes | No | No | No |
| 65 | TDI | I/O | I | N/A | Yes | Up | No | No |
| 66 | TDO | O | O | N/A | Yes | No | No | No |
| 67 | V _{DD} | | | | | | | |
| 68 | PD0 | I/O | I | N/A | Yes | No | No | OD & OS |
| 69 | PD1 | I/O | I | N/A | Yes | No | No | OD & OS |
| 70 | PD2 | I/O | I | N/A | Yes | No | No | OD & OS |
| 71 | PD3 | I/O | I | N/A | Yes | No | No | OD & OS |
| 72 | PD4 | I/O | I | N/A | Yes | No | No | OD & OS |
| 73 | PD5 | I/O | I | N/A | Yes | No | No | OD & OS |
| 74 | PD6 | I/O | I | N/A | Yes | No | No | OD & OS |
| 75 | PD7 | I/O | I | N/A | Yes | No | No | OD & OS |
| 76 | PC0 | I/O | I | N/A | Yes | No | No | OD & OS |
| 77 | PC1 | I/O | I | N/A | Yes | No | No | OD & OS |
| 78 | PC2 | I/O | I | N/A | Yes | No | No | OD & OS |
| 79 | PC3 | I/O | I | N/A | Yes | No | No | OD & OS |
| 80 | PC4 | I/O | I | N/A | Yes | No | No | OD & OS |
| 81 | PC5 | I/O | I | N/A | Yes | No | No | OD & OS |
| 82 | PC6 | I/O | I | N/A | Yes | No | No | OD & OS |
| 83 | PC7 | I/O | I | N/A | Yes | No | No | OD & OS |
| 84 | V _{SS} | | | | | | | |
| 85 | X _{IN} | I | I | N/A | N/A | No | No | N/A |
| 86 | X _{OUT} | O | O | N/A | No | No | No | No |
| 87 | V _{DD} | | | | | | | |
| 88 | PB0 | I/O | I | N/A | Yes | No | No | OD & OS |
| 89 | PB1 | I/O | I | N/A | Yes | No | No | OD & OS |



Table 2. Pin Characteristics of the eZ80™ Webserver-i (Continued)

| Pin # | Symbol | Direction | Reset Direction | Active Low/High | Tristate Output | Pull Up/Down | Schmitt Trigger Input | Open Drain/Source |
|-------|-----------------|-----------|-----------------|-----------------|-----------------|--------------|-----------------------|-------------------|
| 90 | PB2 | I/O | I | N/A | Yes | No | No | OD & OS |
| 91 | PB3 | I/O | I | N/A | Yes | No | No | OD & OS |
| 92 | PB4 | I/O | I | N/A | Yes | No | No | OD & OS |
| 93 | PB5 | I/O | I | N/A | Yes | No | No | OD & OS |
| 94 | PB6 | I/O | I | N/A | Yes | No | No | OD & OS |
| 95 | PB7 | I/O | I | N/A | Yes | No | No | OD & OS |
| 96 | V _{DD} | | | | | | | |
| 97 | V _{SS} | | | | | | | |
| 98 | SDA | I/O | I | N/A | Yes | Up | No | OD |
| 99 | SCL | I/O | I | N/A | Yes | Up | No | OD |
| 100 | PHI | O | O | N/A | Yes | No | No | No |



Register Map

All on-chip peripheral registers are accessed in the I/O address space. All I/O operations employ 16-bit addresses. The upper byte of the 24-bit address bus is undefined during all I/O operations (ADDR[23:16] = UU). All I/O operations using 16-bit addresses within the range 0080h–00FFh are routed to the on-chip peripherals. External I/O Chip Selects are not generated if the address space programmed for the I/O Chip Selects overlaps the 0080h–00FFh address range.

Registers at unused addresses within the 0080h–00FFh range assigned to on-chip peripherals are not implemented. READ access to such addresses returns unpredictable values and WRITE access produces no effect. Table 3 diagrams the register map for the eZ80L92.

Table 3. Register Map

| Address (hex) | Mnemonic | Name | Reset (hex) | CPU Access | Page # |
|---|-----------|-----------------------------------|-------------|------------|--------------------|
| Programmable Reload Counter/Timers | | | | | |
| 0080 | TMR0_CTL | Timer 0 Control Register | 00 | R/W | 81 |
| 0081 | TMR0_DR_L | Timer 0 Data Register—Low Byte | 00 | R | 82 |
| | TMR0_RR_L | Timer 0 Reload Register—Low Byte | 00 | W | 83 |
| 0082 | TMR0_DR_H | Timer 0 Data Register—High Byte | 00 | R | 83 |
| | TMR0_RR_H | Timer 0 Reload Register—High Byte | 00 | W | 84 |
| 0083 | TMR1_CTL | Timer 1 Control Register | 00 | R/W | 81 |
| 0084 | TMR1_DR_L | Timer 1 Data Register—Low Byte | 00 | R | 82 |
| | TMR1_RR_L | Timer 1 Reload Register—Low Byte | 00 | W | 83 |
| 0085 | TMR1_DR_H | Timer 1 Data Register—High Byte | 00 | R | 83 |
| | TMR1_RR_H | Timer 1 Reload Register—High Byte | 00 | W | 84 |
| 0086 | TMR2_CTL | Timer 2 Control Register | 00 | R/W | 81 |

Notes:

1. After an external pin reset, the Watch-Dog Timer Control register is reset to 00h. After a Watch-Dog Timer time-out reset, the Watch-Dog Timer Control register is reset to 20h.
2. When the CPU reads this register, the current sampled value of the port is read.
3. Read-only if RTC is locked; Read/Write if RTC is unlocked.
4. After an external pin reset or a WDT reset, the RTC Control register is reset to x0xxxx00b. After an RTC Alarm Sleep-Mode Recovery reset, the RTC Control register is reset to x0xxxx10b.



Table 3. Register Map (Continued)

| Address (hex) | Mnemonic | Name | Reset (hex) | CPU Access | Page # |
|---|-----------|---|----------------|---------------|--------------------|
| Programmable Reload Counter/Timers | | | | | |
| 0087 | TMR2_DR_L | Timer 2 Data Register—Low Byte | 00 | R | 82 |
| | TMR2_RR_L | Timer 2 Reload Register—Low Byte | 00 | W | 83 |
| 0088 | TMR2_DR_H | Timer 2 Data Register—High Byte | 00 | R | 83 |
| | TMR2_RR_H | Timer 2 Reload Register—High Byte | 00 | W | 84 |
| 0089 | TMR3_CTL | Timer 3 Control Register | 00 | R/W | 81 |
| 008A | TMR3_DR_L | Timer 3 Data Register—Low Byte | 00 | R | 82 |
| | TMR3_RR_L | Timer 3 Reload Register—Low Byte | 00 | W | 83 |
| 008B | TMR3_DR_H | Timer 3 Data Register—High Byte | 00 | R | 83 |
| | TMR3_RR_H | Timer 3 Reload Register—High Byte | 00 | W | 84 |
| 008C | TMR4_CTL | Timer 4 Control Register | 00 | R/W | 81 |
| 008D | TMR4_DR_L | Timer 4 Data Register—Low Byte | 00 | R | 82 |
| | TMR4_RR_L | Timer 4 Reload Register—Low Byte | 00 | W | 83 |
| 008E | TMR4_DR_H | Timer 4 Data Register—High Byte | 00 | R | 83 |
| | TMR4_RR_H | Timer 4 Reload Register—High Byte | 00 | W | 84 |
| 008F | TMR5_CTL | Timer 5 Control Register | 00 | R/W | 81 |
| 0090 | TMR5_DR_L | Timer 5 Data Register—Low Byte | 00 | R | 82 |
| | TMR5_RR_L | Timer 5 Reload Register—Low Byte | 00 | W | 83 |
| 0091 | TMR5_DR_H | Timer 5 Data Register—High Byte | 00 | R | 83 |
| | TMR5_RR_H | Timer 5 Reload Register—High Byte | 00 | W | 84 |
| 0092 | TMR_ISS | Timer Input Source Select Register | 00 | R/W | 84 |
| Watch-Dog Timer | | | | | |
| 0093 | WDT_CTL | Watch-Dog Timer Control Register ¹ | 00/20 | R/W | 73 |
| 0094 | WDT_RR | Watch-Dog Timer Reset Register | XX | W | 74 |

Notes:

1. After an external pin reset, the Watch-Dog Timer Control register is reset to 00h. After a Watch-Dog Timer time-out reset, the Watch-Dog Timer Control register is reset to 20h.
2. When the CPU reads this register, the current sampled value of the port is read.
3. Read-only if RTC is locked; Read/Write if RTC is unlocked.
4. After an external pin reset or a WDT reset, the RTC Control register is reset to x0xxxx00b. After an RTC Alarm Sleep-Mode Recovery reset, the RTC Control register is reset to x0xxxx10b.



Table 3. Register Map (Continued)

| Address (hex) | Mnemonic | Name | Reset (hex) | CPU Access | Page # |
|---|----------|------------------------------------|-------------|------------------|--------------------|
| General-Purpose Input/Output Ports | | | | | |
| 009A | PB_DR | Port B Data Register ² | XX | R/W | 43 |
| 009B | PB_DDR | Port B Data Direction Register | FF | R/W | 44 |
| 009C | PB_ALT1 | Port B Alternate Register 1 | 00 | R/W | 44 |
| 009D | PB_ALT2 | Port B Alternate Register 2 | 00 | R/W | 44 |
| 009E | PC_DR | Port C Data Register | XX | R/W ² | 43 |
| 009F | PC_DDR | Port C Data Direction Register | FF | R/W | 44 |
| 00A0 | PC_ALT1 | Port C Alternate Register 1 | 00 | R/W | 44 |
| 00A1 | PC_ALT2 | Port C Alternate Register 2 | 00 | R/W | 44 |
| 00A2 | PD_DR | Port D Data Register | XX | R/W ² | 43 |
| 00A3 | PD_DDR | Port D Data Direction Register | FF | R/W | 44 |
| 00A4 | PD_ALT1 | Port D Alternate Register 1 | 00 | R/W | 44 |
| 00A5 | PD_ALT2 | Port D Alternate Register 2 | 00 | R/W | 44 |
| Chip Select/Wait State Generator | | | | | |
| 00A8 | CS0_LBR | Chip Select 0 Lower Bound Register | 00 | R/W | 67 |
| 00A9 | CS0_UBR | Chip Select 0 Upper Bound Register | FF | R/W | 67 |
| 00AA | CS0_CTL | Chip Select 0 Control Register | E8 | R/W | 68 |
| 00AB | CS1_LBR | Chip Select 1 Lower Bound Register | 00 | R/W | 67 |
| 00AC | CS1_UBR | Chip Select 1 Upper Bound Register | 00 | R/W | 67 |
| 00AD | CS1_CTL | Chip Select 1 Control Register | 00 | R/W | 68 |
| 00AE | CS2_LBR | Chip Select 2 Lower Bound Register | 00 | R/W | 67 |
| 00AF | CS2_UBR | Chip Select 2 Upper Bound Register | 00 | R/W | 67 |
| 00B0 | CS2_CTL | Chip Select 2 Control Register | 00 | R/W | 68 |
| 00B1 | CS3_LBR | Chip Select 3 Lower Bound Register | 00 | R/W | 67 |

Notes:

1. After an external pin reset, the Watch-Dog Timer Control register is reset to 00h. After a Watch-Dog Timer time-out reset, the Watch-Dog Timer Control register is reset to 20h.
2. When the CPU reads this register, the current sampled value of the port is read.
3. Read-only if RTC is locked; Read/Write if RTC is unlocked.
4. After an external pin reset or a WDT reset, the RTC Control register is reset to x0xxxx00b. After an RTC Alarm Sleep-Mode Recovery reset, the RTC Control register is reset to x0xxxx10b.



Table 3. Register Map (Continued)

| Address (hex) | Mnemonic | Name | Reset (hex) | CPU Access | Page # |
|--|-------------|---|----------------|---------------|---------------------|
| Chip Select/Wait State Generator | | | | | |
| 00B2 | CS3_UBR | Chip Select 3 Upper Bound Register | 00 | R/W | 67 |
| 00B3 | CS3_CTL | Chip Select 3 Control Register | 00 | R/W | 68 |
| Serial Peripheral Interface (SPI) Block | | | | | |
| 00B8 | SPI_BRG_L | SPI Baud Rate Generator Register—Low Byte | 02 | R/W | 131 |
| 00B9 | SPI_BRG_H | SPI Baud Rate Generator Register—High Byte | 00 | R/W | 131 |
| 00BA | SPI_CTL | SPI Control Register | 04 | R/W | 132 |
| 00BB | SPI_SR | SPI Status Register | 00 | R | 133 |
| 00BC | SPI_TSR | SPI Transmit Shift Register | XX | W | 134 |
| | SPI_RBR | SPI Receive Buffer Register | XX | R | 134 |
| Infrared Encoder/Decoder Block | | | | | |
| 00BF | IR_CTL | Infrared Encoder/Decoder Control | 00 | R/W | 124 |
| Universal Asynchronous Receiver/Transmitter 0 (UART0) Block | | | | | |
| 00C0 | UART0_RBR | UART 0 Receive Buffer Register | XX | R | 110 |
| | UART0_THR | UART 0 Transmit Holding Register | XX | W | 109 |
| | UART0_BRG_L | UART 0 Baud Rate Generator Register—Low Byte | 02 | R/W | 108 |
| 00C1 | UART0_IER | UART 0 Interrupt Enable Register | 00 | R/W | 110 |
| | UART0_BRG_H | UART 0 Baud Rate Generator Register—High Byte | 00 | R/W | 108 |
| 00C2 | UART0_IIR | UART 0 Interrupt Identification Register | 01 | R | 111 |
| | UART0_FCTL | UART 0 FIFO Control Register | 00 | W | 112 |
| 00C3 | UART0_LCTL | UART 0 Line Control Register | 00 | R/W | 113 |

Notes:

1. After an external pin reset, the Watch-Dog Timer Control register is reset to 00h. After a Watch-Dog Timer time-out reset, the Watch-Dog Timer Control register is reset to 20h.
2. When the CPU reads this register, the current sampled value of the port is read.
3. Read-only if RTC is locked; Read/Write if RTC is unlocked.
4. After an external pin reset or a WDT reset, the RTC Control register is reset to x0xxxx00b. After an RTC Alarm Sleep-Mode Recovery reset, the RTC Control register is reset to x0xxxx10b.



Table 3. Register Map (Continued)

| Address (hex) | Mnemonic | Name | Reset (hex) | CPU Access | Page # |
|--|-------------|---|----------------|---------------|---------------------|
| Universal Asynchronous Receiver/Transmitter 0 (UART0) Block | | | | | |
| 00C4 | UART0_MCTL | UART 0 Modem Control Register | 00 | R/W | 115 |
| 00C5 | UART0_LSR | UART 0 Line Status Register | 60 | R | 116 |
| 00C6 | UART0_MSR | UART 0 Modem Status Register | XX | R | 118 |
| 00C7 | UART0_SPR | UART 0 Scratch Pad Register | 00 | R/W | 119 |
| I²C Block | | | | | |
| 00C8 | I2C_SAR | I ² C Slave Address Register | 00 | R/W | 148 |
| 00C9 | I2C_XSAR | I ² C Extended Slave Address Register | 00 | R/W | 149 |
| 00CA | I2C_DR | I ² C Data Register | 00 | R/W | 149 |
| 00CB | I2C_CTL | I ² C Control Register | 00 | R/W | 151 |
| 00CC | I2C_SR | I ² C Status Register | F8 | R | 152 |
| | I2C_CCR | I ² C Clock Control Register | 00 | W | 154 |
| 00CD | I2C_SRR | I ² C Software Reset Register | XX | W | 155 |
| Universal Asynchronous Receiver/Transmitter 1 (UART1) Block | | | | | |
| 00D0 | UART1_RBR | UART 1 Receive Buffer Register | XX | R | 110 |
| | UART1_THR | UART 1 Transmit Holding Register | XX | W | 109 |
| | UART1_BRG_L | UART 1 Baud Rate Generator Register— Low Byte | 02 | R/W | 108 |
| 00D1 | UART1_IER | UART 1 Interrupt Enable Register | 00 | R/W | 110 |
| | UART1_BRG_H | UART 1 Baud Rate Generator Register— High Byte | 00 | R/W | 108 |
| 00D2 | UART1_IIR | UART 1 Interrupt Identification Register | 01 | R | 111 |
| | UART1_FCTL | UART 1 FIFO Control Register | 00 | W | 112 |
| 00D3 | UART1_LCTL | UART 1 Line Control Register | 00 | R/W | 113 |
| 00D4 | UART1_MCTL | UART 1 Modem Control Register | 00 | R/W | 115 |

Notes:

1. After an external pin reset, the Watch-Dog Timer Control register is reset to 00h. After a Watch-Dog Timer time-out reset, the Watch-Dog Timer Control register is reset to 20h.
2. When the CPU reads this register, the current sampled value of the port is read.
3. Read-only if RTC is locked; Read/Write if RTC is unlocked.
4. After an external pin reset or a WDT reset, the RTC Control register is reset to x0xxxx00b. After an RTC Alarm Sleep-Mode Recovery reset, the RTC Control register is reset to x0xxxx10b.



Table 3. Register Map (Continued)

| Address (hex) | Mnemonic | Name | Reset (hex) | CPU Access | Page # |
|--|-----------|--|-------------------------|------------------|---------------------|
| Universal Asynchronous Receiver/Transmitter 1 (UART1) Block | | | | | |
| 00D5 | UART1_LSR | UART 1 Line Status Register | 60 | R/W | 116 |
| 00D6 | UART1_MSR | UART 1 Modem Status Register | XX | R/W | 118 |
| 00D7 | UART1_SPR | UART 1 Scratch Pad Register | 00 | R/W | 119 |
| Low-Power Control | | | | | |
| 00DB | CLK_PPD1 | Clock Peripheral Power-Down Register 1 | 00 | R/W | 37 |
| 00DC | CLK_PPD2 | Clock Peripheral Power-Down Register 2 | 00 | R/W | 38 |
| Real-Time Clock | | | | | |
| 00E0 | RTC_SEC | RTC Seconds Register ³ | XX | R/W | 88 |
| 00E1 | RTC_MIN | RTC Minutes Register | XX | R/W ³ | 89 |
| 00E2 | RTC_HRS | RTC Hours Register | XX | R/W ³ | 90 |
| 00E3 | RTC_DOW | RTC Day-of-the-Week Register | XX | R/W ³ | 91 |
| 00E4 | RTC_DOM | RTC Day-of-the-Month Register | XX | R/W ³ | 92 |
| 00E5 | RTC_MON | RTC Month Register | XX | R/W ³ | 93 |
| 00E6 | RTC_YR | RTC Year Register | XX | R/W ³ | 94 |
| 00E7 | RTC_CEN | RTC Century Register | XX | R/W ³ | 95 |
| 00E8 | RTC_ASEC | RTC Alarm Seconds Register | XX | R/W | 96 |
| 00E9 | RTC_AMIN | RTC Alarm Minutes Register | XX | R/W | 97 |
| 00EA | RTC_AHRS | RTC Alarm Hours Register | XX | R/W | 98 |
| 00EB | RTC_ADOW | RTC Alarm Day-of-the-Week Register | 0X | R/W | 99 |
| 00EC | RTC_ACTRL | RTC Alarm Control Register | 00 | R/W | 100 |
| 00ED | RTC_CTRL | RTC Control Register ⁴ | x0xxxx00b/ x0xxxx10b | R/W | 101 |

Notes:

1. After an external pin reset, the Watch-Dog Timer Control register is reset to 00h. After a Watch-Dog Timer time-out reset, the Watch-Dog Timer Control register is reset to 20h.
2. When the CPU reads this register, the current sampled value of the port is read.
3. Read-only if RTC is locked; Read/Write if RTC is unlocked.
4. After an external pin reset or a WDT reset, the RTC Control register is reset to x0xxxx00b. After an RTC Alarm Sleep-Mode Recovery reset, the RTC Control register is reset to x0xxxx10b.



Table 3. Register Map (Continued)

| Address (hex) | Mnemonic | Name | Reset (hex) | CPU Access | Page # |
|-------------------------------------|----------|---|----------------|---------------|--------------------|
| Chip Select Bus Mode Control | | | | | |
| 00F0 | CS0_BMC | Chip Select 0 Bus Mode Control Register | 02h | R/W | 69 |
| 00F1 | CS1_BMC | Chip Select 1 Bus Mode Control Register | 02h | R/W | 69 |
| 00F2 | CS2_BMC | Chip Select 2 Bus Mode Control Register | 02h | R/W | 69 |
| 00F3 | CS3_BMC | Chip Select 3 Bus Mode Control Register | 02h | R/W | 69 |

Notes:

1. After an external pin reset, the Watch-Dog Timer Control register is reset to 00h. After a Watch-Dog Timer time-out reset, the Watch-Dog Timer Control register is reset to 20h.
2. When the CPU reads this register, the current sampled value of the port is read.
3. Read-only if RTC is locked; Read/Write if RTC is unlocked.
4. After an external pin reset or a WDT reset, the RTC Control register is reset to x0xxxx00b. After an RTC Alarm Sleep-Mode Recovery reset, the RTC Control register is reset to x0xxxx10b.



eZ80[®] CPU Core

The eZ80[®] CPU is the first 8-bit microprocessor to support 16MB linear addressing. Each software module or task under a real-time executive or operating system can operate in Z80-compatible (64KB) mode or full 24-bit (16MB) address mode.

The eZ80[®] CPU instruction set is a superset of the instruction sets for the Z80 and Z180 CPUs. Z80 and Z180 programs can be executed on an eZ80[®] CPU with little or no modification.

Features

- Code-compatible with Z80 and Z180 products
- 24-bit linear address space
- Single-cycle instruction fetch
- Pipelined fetch, decode, and execute
- Dual Stack Pointers for ADL (24-bit) and Z80 (16-bit) memory modes
- 24-bit CPU registers and ALU (Arithmetic Logic Unit)
- Debug support
- Nonmaskable Interrupt (NMI), plus support for 128 maskable vectored interrupts

New and Improved Instructions

- Four new block transfer instructions provide DMA-like operations for memory to I/O and I/O to memory transfers. These new instructions are:
 - INDRX (input from I/O, decrement the memory address, leave the I/O address unchanged, and repeat)
 - INIRX (input from I/O, increment the memory address, leave the I/O address unchanged, and repeat)
 - OTDRX (output to I/O, decrement the memory address, leave the I/O address unchanged, and repeat)
 - OTIRX (output to I/O, increment the memory address, leave the I/O address unchanged, and repeat)



- Four other block transfer instructions are modified to improve performance relative to the eZ80190 device. These modified instructions are:
 - IND2R (input from I/O, decrement the memory address, decrement the I/O address, and repeat)
 - INI2R (input from I/O, increment the memory address, increment the I/O address, and repeat)
 - OTD2R (output to I/O, decrement the memory address, decrement the I/O address, and repeat)
 - OTI2R (output to I/O, increment the memory address, increment the I/O address, and repeat)

For more information on the eZ80[®] CPU, its instruction set, and eZ80[®] programming, please refer to the eZ80 CPU User Manual. For more information on the eZ80190, please refer to the eZ80190 Product Specification.



Reset

RESET Operation

The RESET controller within the eZ80L92 provides a consistent system reset (RESET) function for all type of resets that may affect the system. There are 4 events which can cause a RESET:

- External $\overline{\text{RESET}}$ pin assertion
- Watch-Dog Timer (WDT) time-out when configured to generate a RESET
- Real-Time Clock alarm with the eZ80[®] CPU in low-power SLEEP mode
- Execution of a Debug RESET command

During RESET, an internal RESET mode timer holds the system in RESET for 257 system clock (SCLK) cycles. The RESET mode timer begins incrementing on the next rising edge of SCLK following deactivation of all RESET events (RESET pin, Watch-Dog Timer, Real-Time Clock, Debugger)

- **Note:** User must determine if 257 SCLK cycles provides sufficient time for the primary crystal oscillator to stabilize.

RESET, via the external $\overline{\text{RESET}}$ pin, must always be executed following application of power (V_{DD} ramp). Without RESET following power-up, proper operation of the eZ80L92 cannot be guaranteed.



Low-Power Modes

Overview

The eZ80L92 provides a range of power-saving features. The highest level of power reduction is provided by SLEEP mode. The next level of power reduction is provided by the HALT instruction. The lowest level of power reduction is provided by the clock peripheral power-down registers.

SLEEP Mode

Execution of the eZ80[®] CPU's SLP instruction places the eZ80L92 into SLEEP mode. In SLEEP mode, the operating characteristics are:

- Primary crystal oscillator is disabled
- System clock is disabled
- eZ80[®] CPU is idle
- Program counter (PC) stops incrementing
- 32KHz crystal oscillator continues to operate and drive the Real-Time Clock and the Watch-Dog Timer (if WDT is configured to operate from the 32KHz oscillator)

The eZ80[®] CPU can be brought out of SLEEP mode by any of the following operations:

- RESET via the external $\overline{\text{RESET}}$ pin driven Low
- RESET via a Real-Time Clock alarm
- RESET via a Watch-Dog Timer time-out (if running off of the 32KHz oscillator and configured to generate a RESET upon time-out)
- RESET via execution of a Debug RESET command

After exiting SLEEP mode, the standard RESET delay occurs to allow the primary crystal oscillator to stabilize. Refer to the [Reset](#) section on page 34 for more information.



HALT Mode

Execution of the eZ80[®] CPU's HALT instruction places the eZ80L92 into HALT mode. In HALT mode, the operating characteristics are:

- Primary crystal oscillator is enabled and continues to operate
- System clock is enabled and continues to operate
- eZ80[®] CPU is idle
- Program counter (PC) stops incrementing

The eZ80[®] CPU can be brought out of HALT mode by any of the following operations:

- Nonmaskable interrupt (NMI)
- Maskable interrupt
- RESET via the external $\overline{\text{RESET}}$ pin driven Low
- Watch-Dog Timer time-out (if configured to generate either an NMI or RESET upon time-out)
- RESET via execution of a Debug RESET command

To minimize current in HALT mode, the system clock should be disabled for all unused on-chip peripherals via the Clock Peripheral Power-Down Registers.

Clock Peripheral Power-Down Registers

To reduce power, the Clock Peripheral Power-Down Registers allow the system clock to be disabled to unused on-chip peripherals. Upon RESET, all peripherals are enabled. The clock to unused peripherals can be disabled by setting the appropriate bit in the Clock Peripheral Power-Down Registers to 1. When powered down, the peripherals are completely disabled. To reenables, the bit in the Clock Peripheral Power-Down Registers must be cleared to 0.

Many peripherals feature separate enable/disable control bits that must be appropriately set for operation. These peripheral specific enable/disable bits do not provide the same level of power reduction as the Clock Peripheral Power-Down Registers. When powered down, the standard peripheral control registers are not accessible for read or write access. See Tables 4 and 5.



Table 4. Clock Peripheral Power-Down Register 1 (CLK_PPD1 = 00DBh)

| Bit | 7 | 6 | 5 | 4 | 3 | 2 | 1 | 0 |
|------------|-----|-----|-----|---|-----|-----|-----|-----|
| Reset | 0 | 0 | 0 | 0 | 0 | 0 | 0 | 0 |
| CPU Access | R/W | R/W | R/W | R | R/W | R/W | R/W | R/W |

Note: R/W = Read/Write; R = Read Only.

| Bit Position | Value | Description |
|-----------------|-------|---|
| 7 GPIO_D_OFF | 1 | System clock to GPIO Port D is powered down. Port D alternate functions do not operate correctly. |
| | 0 | System clock to GPIO Port D is powered up. |
| 6 GPIO_C_OFF | 1 | System clock to GPIO Port C is powered down. Port C alternate functions do not operate correctly. |
| | 0 | System clock to GPIO Port C is powered up. |
| 5 GPIO_B_OFF | 1 | System clock to GPIO Port B is powered down. Port B alternate functions do not operate correctly. |
| | 0 | System clock to GPIO Port B is powered up. |
| 4 | | Reserved. |
| 3 SPI_OFF | 1 | System clock to SPI is powered down. |
| | 0 | System clock to SPI is powered up. |
| 2 I2C_OFF | 1 | System clock to I ² C is powered down. |
| | 0 | System clock to I ² C is powered up. |
| 1 UART1_OFF | 1 | System clock to UART1 is powered down. |
| | 0 | System clock to UART1 is powered up. |
| 0 UART0_OFF | 1 | System clock to UART0 and IrDA endec is powered down. |
| | 0 | System clock to UART0 and IrDA endec is powered up. |



Table 5. Clock Peripheral Power-Down Register 2 (CLK_PPD2 = 00DCh)

| Bit | 7 | 6 | 5 | 4 | 3 | 2 | 1 | 0 |
|------------|-----|---|-----|-----|-----|-----|-----|-----|
| Reset | 0 | 0 | 0 | 0 | 0 | 0 | 0 | 0 |
| CPU Access | R/W | R | R/W | R/W | R/W | R/W | R/W | R/W |

Note: R/W = Read/Write; R = Read Only.

| Bit Position | Value | Description |
|---------------|--------|--|
| 7 PHI_OFF | 1 0 | PHI Clock output is disabled (output is high-impedance). PHI Clock output is enabled. |
| 6 | 0 | Reserved. |
| 5 PRT5_OFF | 1 0 | System clock to PRT5 is powered down. System clock to PRT5 is powered up. |
| 4 PRT4_OFF | 1 0 | System clock to PRT4 is powered down. System clock to PRT4 is powered up. |
| 3 PRT3_OFF | 1 0 | System clock to PRT3 is powered down. System clock to PRT3 is powered up. |
| 2 PRT2_OFF | 1 0 | System clock to PRT2 is powered down. System clock to PRT2 is powered up. |
| 1 PRT1_OFF | 1 0 | System clock to PRT1 is powered down. System clock to PRT1 is powered up. |
| 0 PRT0_OFF | 1 0 | System clock to PRT0 is powered down. System clock to PRT0 is powered up. |



General-Purpose Input/Output

GPIO Overview

The eZ80L92 features 24 General-Purpose Input/Output (GPIO) pins. The GPIO pins are assembled as three 8-bit ports— Port B, Port C, and Port D. All port signals can be configured for use as either inputs or outputs. In addition, all of the port pins can be used as vectored interrupt sources for the eZ80[®] CPU.

GPIO Operation

The GPIO operation is the same for all 3 GPIO ports (Ports B, C, and D). Each port features eight GPIO port pins. The operating mode for each pin is controlled by four bits that are divided between four 8-bit registers. These GPIO mode control registers are:

- Port *x* Data Register (Px_DR)
- Port *x* Data Direction Register (Px_DDR)
- Port *x* Alternate Register 1 (Px_ALT1)
- Port *x* Alternate Register 2 (Px_ALT2)

where *x* can be *B*, *C*, or *D* representing any of the three GPIO ports B, C, or D. The mode for each pin is controlled by setting each register bit pertinent to the pin to be configured. For example, the operating mode for Port B Pin 7 (PB7), is set by the values contained in PB_DR[7], PB_DDR[7], PB_ALT1[7], and PB_ALT2[7].

The combination of the GPIO control register bits allows individual configuration of each port pin for nine modes. In all modes, reading of the Port *x* Data register returns the sampled state, or level, of the signal on the corresponding pin. Table 6 indicates the function of each port signal based upon these four register bits. After a RESET event, all GPIO port pins are configured as standard digital inputs, with interrupts disabled.



Table 6. GPIO Mode Selection

| GPIO Mode | Px_ALT2 Bits7:0 | Px_ALT1 Bits7:0 | Px_DDR Bits7:0 | Px_DR Bits7:0 | Port Mode | Output |
|-----------|-----------------|-----------------|----------------|---------------|---|----------------|
| 1 | 0 | 0 | 0 | 0 | Output | 0 |
| | 0 | 0 | 0 | 1 | Output | 1 |
| 2 | 0 | 0 | 1 | 0 | Input from pin | High impedance |
| | 0 | 0 | 1 | 1 | Input from pin | High impedance |
| 3 | 0 | 1 | 0 | 0 | Open-Drain output | 0 |
| | 0 | 1 | 0 | 1 | Open-Drain I/O | High impedance |
| 4 | 0 | 1 | 1 | 0 | Open source I/O | High impedance |
| | 0 | 1 | 1 | 1 | Open source output | 1 |
| 5 | 1 | 0 | 0 | 0 | Reserved | High impedance |
| 6 | 1 | 0 | 0 | 1 | Interrupt—dual edge triggered | High impedance |
| 7 | 1 | 0 | 1 | 0 | Port B, C, or D—alternate function controls port I/O. | |
| | 1 | 0 | 1 | 1 | Port B, C, or D—alternate function controls port I/O. | |
| 8 | 1 | 1 | 0 | 0 | Interrupt—active Low | High impedance |
| | 1 | 1 | 0 | 1 | Interrupt—active High | High impedance |
| 9 | 1 | 1 | 1 | 0 | Interrupt—falling edge triggered | High impedance |
| | 1 | 1 | 1 | 1 | Interrupt—rising edge triggered | High impedance |

GPIO Mode 1. The port pin is configured as a standard digital output pin. The value written to the Port x Data register (Px_DR) is presented on the pin.

GPIO Mode 2. The port pin is configured as a standard digital input pin. The output is tristated (high impedance). The value stored in the Port x Data register produces no effect. As in all modes, a Read from the Port x Data register returns the pin's value. GPIO Mode 2 is the default operating mode following a RESET.

GPIO Mode 3. The port pin is configured as open-drain I/O. The GPIO pins do not feature an internal pull-up to the supply voltage. To employ the GPIO pin in OPEN-DRAIN mode, an external pull-up resistor must connect the pin to the supply voltage. Writing a 0 to the Port x Data register outputs a Low at the pin. Writing a 1 to the Port x Data register results in high-impedance output.

GPIO Mode 4. The port pin is configured as open-source I/O. The GPIO pins do not feature an internal pull-down to the supply ground. To employ the GPIO pin in OPEN-SOURCE mode, an external pull-down resistor must connect the pin to the



supply ground. Writing a 1 to the Port x Data register outputs a High at the pin. Writing a 0 to the Port x Data register results in a high-impedance output.

GPIO Mode 5. Reserved. This pin produces high-impedance output.

GPIO Mode 6. This bit enables a dual edge-triggered interrupt mode. Both a rising and a falling edge on the pin cause an interrupt request to be sent to the eZ80[®] CPU. Writing a 1 to the Port x Data register bit position resets the corresponding interrupt request. Writing a 0 produces no effect. The programmer must set the Port x Data register before entering the edge-triggered interrupt mode.

GPIO Mode 7. For Ports B, C, and D, the port pin is configured to pass control over to the alternate (secondary) functions assigned to the pin. For example, the alternate mode function for PC7 is RI1 and the alternate mode function for PB4 is the Timer 4 Out. When GPIO Mode 7 is enabled, the pin output data and pin tristated control come from the alternate function's data output and tristate control, respectively. The value in the Port x Data register produces no effect on operation.

► **Note:** Input signals are sampled by the system clock before being passed to the alternate function input.

GPIO Mode 8. The port pin is configured for level-sensitive interrupt modes. An interrupt request is generated when the level at the pin is the same as the level stored in the Port x Data register. The port pin value is sampled by the system clock. The input pin must be held at the selected interrupt level for a minimum of 2 clock periods to initiate an interrupt. The interrupt request remains active as long as this condition is maintained at the external source.

GPIO Mode 9. The port pin is configured for single edge-triggered interrupt mode. The value in the Port x Data register determines if a positive or negative edge causes an interrupt request. A 0 in the Port x Data register bit sets the selected pin to generate an interrupt request for falling edges. A 1 in the Port x Data register bit sets the selected pin to generate an interrupt request for rising edges. The interrupt request remains active until a 1 is written to the corresponding interrupt request of the Port x Data register bit. Writing a 0 produces no effect on operation. The programmer must set the Port x Data register before entering the edge-triggered interrupt mode.

A simplified block diagram of a GPIO port pin is illustrated in Figure 3.

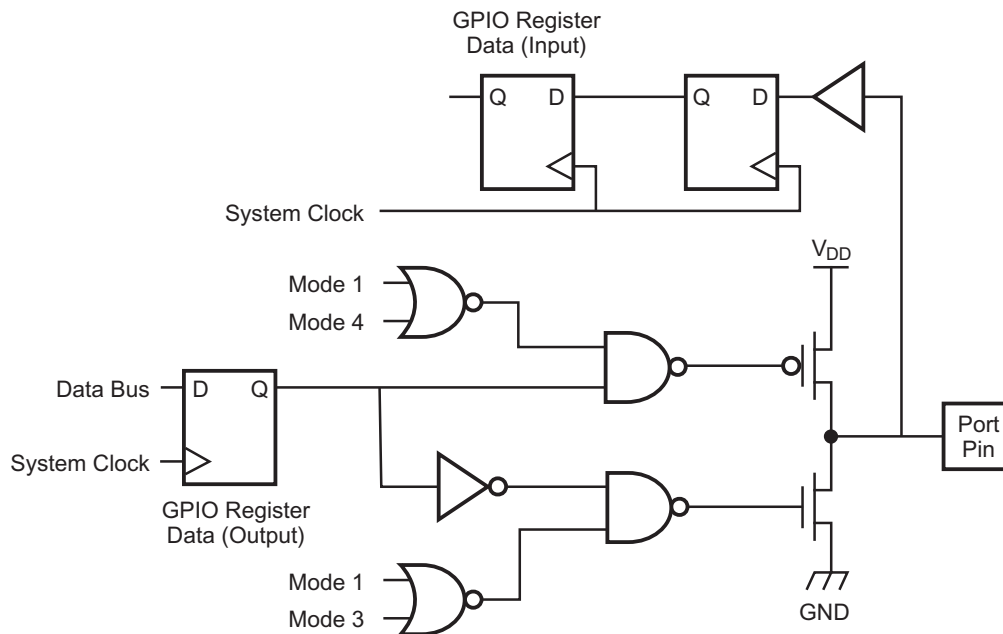

Figure 3. GPIO Port Pin Block Diagram

GPIO Interrupts

Each port pin can be used as an interrupt source. Interrupts can be either level- or edge-triggered.

Level-Triggered Interrupts

When the port is configured for level-triggered interrupts, the corresponding port pin is tristated. An interrupt request is generated when the level at the pin is the same as the level stored in the Port x Data register. The port pin value is sampled by the system clock. The input pin must be held at the selected interrupt level for a minimum of 2 consecutive clock cycles to initiate an interrupt. The interrupt request remains active as long as this condition is maintained at the external source.

For example, if PD3 is programmed for low-level interrupt and the pin is forced Low for 2 consecutive clock cycles, an interrupt request signal is generated from that port pin and sent to the eZ80[®] CPU. The interrupt request signal remains active until the external device driving PD3 forces the pin High.

Edge-Triggered Interrupts

When the port is configured for edge-triggered interrupts, the corresponding port pin is tristated. If the pin receives the correct edge from an external device, the



port pin generates an interrupt request signal to the eZ80[®] CPU. Any time a port pin is configured for edge-triggered interrupt, writing a 1 to that pin's Port x Data register causes a reset of the edge-detected interrupt. The programmer must set the bit in the Port x Data register to 1 before entering either single or dual edge-triggered interrupt mode for that port pin.

When configured for dual edge-triggered interrupt mode (GPIO Mode 6), both a rising and a falling edge on the pin cause an interrupt request to be sent to the eZ80[®] CPU.

When configured for single edge-triggered interrupt mode (GPIO Mode 9), the value in the Port x Data register determines if a positive or negative edge causes an interrupt request. A 0 in the Port x Data register bit sets the selected pin to generate an interrupt request for falling edges. A 1 in the Port x Data register bit sets the selected pin to generate an interrupt request for rising edges.

GPIO Control Registers

The 12 GPIO Control Registers operate in groups of four with a set for each Port (B, C, and D). Each GPIO port features a Port Data register, Port Data Direction register, Port Alternate register 1, and Port Alternate register 2.

Port x Data Registers

When the port pins are configured for one of the output modes, the data written to the Port x Data registers, detailed in Table 7, are driven on the corresponding pins. In all modes, reading from the Port x Data registers always returns the current sampled value of the corresponding pins. When the port pins are configured as edge-triggered interrupt sources, writing a 1 to the corresponding bit in the Port x Data register clears the interrupt signal that is sent to the eZ80[®] CPU. When the port pins are configured for edge-selectable interrupts or level-sensitive interrupts, the value written to the Port x Data register bit selects the interrupt edge or interrupt level. See [Table 6](#) for more information.

Table 7. Port x Data Registers (PB_DR = 009Ah, PC_DR = 009Eh, PD_DR = 00A2h)

| Bit | 7 | 6 | 5 | 4 | 3 | 2 | 1 | 0 |
|------------|-----|-----|-----|-----|-----|-----|-----|-----|
| Reset | X | X | X | X | X | X | X | X |
| CPU Access | R/W | R/W | R/W | R/W | R/W | R/W | R/W | R/W |

Note: X = Undefined; R/W = Read/Write.



Port x Data Direction Registers

In conjunction with the other GPIO Control Registers, the Port x Data Direction registers, detailed in Table 8, control the operating modes of the GPIO port pins. See [Table 6](#) for more information.

Table 8. Port x Data Direction Registers
(PB_DDR = 009Bh, PC_DDR = 009Fh, PD_DDR = 00A3h)

| Bit | 7 | 6 | 5 | 4 | 3 | 2 | 1 | 0 |
|------------|-----|-----|-----|-----|-----|-----|-----|-----|
| Reset | 1 | 1 | 1 | 1 | 1 | 1 | 1 | 1 |
| CPU Access | R/W | R/W | R/W | R/W | R/W | R/W | R/W | R/W |

Note: R/W = Read/Write.

Port x Alternate Register 1

In conjunction with the other GPIO Control Registers, the Port x Alternate Register 1, detailed in Table 9, control the operating modes of the GPIO port pins. See [Table 6](#) for more information.

Table 9. Port x Alternate Registers 1
(PB_ALT1 = 009Ch, PC_ALT1 = 00A0h, PD_ALT1 = 00A4h)

| Bit | 7 | 6 | 5 | 4 | 3 | 2 | 1 | 0 |
|------------|-----|-----|-----|-----|-----|-----|-----|-----|
| Reset | 0 | 0 | 0 | 0 | 0 | 0 | 0 | 0 |
| CPU Access | R/W | R/W | R/W | R/W | R/W | R/W | R/W | R/W |

Note: R/W = Read/Write.

Port x Alternate Register 2

In conjunction with the other GPIO Control Registers, the Port x Alternate Register 2, detailed in Table 10, control the operating modes of the GPIO port pins. See [Table 6](#) for more information.

Table 10. Port x Alternate Registers 2
(PB_ALT2 = 009Dh, PC_ALT2 = 00A1h, PD_ALT2 = 00A5h)

| Bit | 7 | 6 | 5 | 4 | 3 | 2 | 1 | 0 |
|------------|-----|-----|-----|-----|-----|-----|-----|-----|
| Reset | 0 | 0 | 0 | 0 | 0 | 0 | 0 | 0 |
| CPU Access | R/W | R/W | R/W | R/W | R/W | R/W | R/W | R/W |

Note: R/W = Read/Write.



Interrupt Controller

The interrupt controller on the eZ80L92 routes the interrupt request signals from the internal peripherals and external devices (via the GPIO pins) to the eZ80[®] CPU.

Maskable Interrupts

On the eZ80L92, all maskable interrupts use the eZ80[®] CPU's vectored interrupt function. Table 11 lists the low-byte vector for each of the maskable interrupt sources. The maskable interrupt sources are listed in order of their priority, with vector 00h being the highest-priority interrupt. The full 16-bit interrupt vector is located at starting address $\{I[7:0], IVECT[7:0]\}$ where $I[7:0]$ is the eZ80[®] CPU's Interrupt Page Address Register.

Table 11. Interrupt Vector Sources by Priority

| Vector | Source | Vector | Source | Vector | Source | Vector | Source |
|--------|--------|--------|------------------|--------|----------|--------|----------|
| 00h | Unused | 1Ah | UART 1 | 34h | Port B 2 | 4Eh | Port C 7 |
| 02h | Unused | 1Ch | I ² C | 36h | Port B 3 | 50h | Port D 0 |
| 04h | Unused | 1Eh | SPI | 38h | Port B 4 | 52h | Port D 1 |
| 06h | Unused | 20h | Unused | 3Ah | Port B 5 | 54h | Port D 2 |
| 08h | Unused | 22h | Unused | 3Ch | Port B 6 | 56h | Port D 3 |
| 0Ah | PRT 0 | 24h | Unused | 3Eh | Port B 7 | 58h | Port D 4 |
| 0Ch | PRT 1 | 26h | Unused | 40h | Port C 0 | 5Ah | Port D 5 |
| 0Eh | PRT 2 | 28h | Unused | 42h | Port C 1 | 5Ch | Port D 6 |
| 10h | PRT 3 | 2Ah | Unused | 44h | Port C 2 | 5Eh | Port D 7 |
| 12h | PRT 4 | 2Ch | Unused | 46h | Port C 3 | 60h | Unused |
| 14h | PRT 5 | 2Eh | Unused | 48h | Port C 4 | 62h | Unused |
| 16h | RTC | 30h | Port B 0 | 4Ah | Port C 5 | 64h | Unused |
| 18h | UART 0 | 32h | Port B 1 | 4Ch | Port C 6 | 66h | Unused |

Note: Absolute locations 00h, 08h, 10h, 18h, 20h, 28h, 30h, 38h, and 66h are reserved for hardware reset, NMI, and the RST instruction.

The user's program should store the interrupt service routine starting address in the two-byte interrupt vector locations. For example, for ADL mode the two-byte address for the SPI interrupt service routine would be stored at $\{00h, I[7:0], 1Eh\}$



and {00h, I[7:0], 1Fh}. In Z80 mode, the two-byte address for the SPI interrupt service routine would be stored at {MBASE[7:0], I[7:0], 1Eh} and {MBASE, I[7:0], 1Fh}. The least significant byte is stored at the lower address.

When any one or more of the interrupt requests (IRQs) become active, an interrupt request is generated by the interrupt controller and sent to the CPU. The corresponding 8-bit interrupt vector for the highest priority interrupt is placed on the 8-bit interrupt vector bus, IVECT[7:0]. The interrupt vector bus is internal to the eZ80L92 and is therefore not visible externally. The response time of the eZ80[®] CPU to an interrupt request is a function of the current instruction being executed as well as the number of WAIT states being asserted. The interrupt vector, {I[7:0], IVECT[7:0]}, is visible on the address bus, ADDR[15:0], when the interrupt service routine begins. The response of the eZ80[®] CPU to a vectored interrupt on the eZ80L92 is explained in Table 12. Interrupt sources are required to be active until the Interrupt Service Routine (ISR) starts. It is recommended that the Interrupt Page Address Register (I) value be changed by the user from its default value of 00h as this address can create conflicts between the nonmaskable interrupt vector, the RST instruction addresses, and the maskable interrupt vectors.

Table 12. Vectored Interrupt Operation

| Memory Mode | ADL Bit | MADL Bit | Operation |
|-------------|---------|----------|--|
| Z80 Mode | 0 | 0 | <p>Read the LSB of the interrupt vector placed on the internal vectored interrupt bus, IVECT [7:0], by the interrupting peripheral.</p> <ul style="list-style-type: none"> • IEF1 ← 0 • IEF2 ← 0 • The starting Program Counter is effectively {MBASE, PC[15:0]}. • Push the 2-byte return address PC[15:0] onto the ({MBASE, SPS}) stack. • The ADL mode bit remains cleared to 0. • The interrupt vector address is located at { MBASE, I[7:0], IVECT[7:0] }. • PC[15:0] ← ({ MBASE, I[7:0], IVECT[7:0] }). • The ending Program Counter is effectively {MBASE, PC[15:0]} • The interrupt service routine must end with RETI. |
| ADL Mode | 1 | 0 | <p>Read the LSB of the interrupt vector placed on the internal vectored interrupt bus, IVECT [7:0], by the interrupting peripheral.</p> <ul style="list-style-type: none"> • IEF1 ← 0 • IEF2 ← 0 • The starting Program Counter is PC[23:0]. • Push the 3-byte return address, PC[23:0], onto the SPL stack. • The ADL mode bit remains set to 1. • The interrupt vector address is located at { 00h, I[7:0], IVECT[7:0] }. • PC[15:0] ← ({ 00h, I[7:0], IVECT[7:0] }). • The ending Program Counter is { 00h, PC[15:0] }. • The interrupt service routine must end with RETI. |



Table 12. Vectored Interrupt Operation (Continued)

| Memory Mode | ADL Bit | MADL Bit | Operation |
|-------------|---------|----------|--|
| Z80 Mode | 0 | 1 | <p>Read the LSB of the interrupt vector placed on the internal vectored interrupt bus, IVECT[7:0], bus by the interrupting peripheral.</p> <ul style="list-style-type: none"> • IEF1 \leftarrow 0 • IEF2 \leftarrow 0 • The starting Program Counter is effectively {MBASE, PC[15:0]}. • Push the 2-byte return address, PC[15:0], onto the SPL stack. • Push a 00h byte onto the SPL stack to indicate an interrupt from Z80 mode (because ADL = 0). • Set the ADL mode bit to 1. • The interrupt vector address is located at { 00h, I[7:0], IVECT[7:0] }. • PC[15:0] \leftarrow ({ 00h, I[7:0], IVECT[7:0] }). • The ending Program Counter is { 00h, PC[15:0] }. • The interrupt service routine must end with RETI.L |
| ADL Mode | 1 | 1 | <p>Read the LSB of the interrupt vector placed on the internal vectored interrupt bus, IVECT [7:0], by the interrupting peripheral.</p> <ul style="list-style-type: none"> • IEF1 \leftarrow 0 • IEF2 \leftarrow 0 • The starting Program Counter is PC[23:0]. • Push the 3-byte return address, PC[23:0], onto the SPL stack. • Push a 01h byte onto the SPL stack to indicate a restart from ADL mode (because ADL = 1). • The ADL mode bit remains set to 1. • The interrupt vector address is located at {00h, I[7:0], IVECT[7:0]}. • PC[15:0] \leftarrow ({ 00h, I[7:0], IVECT[7:0] }). • The ending Program Counter is { 00h, PC[15:0] }. • The interrupt service routine must end with RETI.L |

Nonmaskable Interrupts

An active Low input on the NMI pin generates an interrupt request to the eZ80[®] CPU. This nonmaskable interrupt is always serviced by the eZ80[®] CPU, regardless of the state of the Interrupt Enable flags (IEF1 and IEF2). The nonmaskable interrupt is prioritized higher than all maskable interrupts. The response of the eZ80[®] CPU to a nonmaskable interrupt is described in detail in the eZ80[®] CPU User Manual (UM0077).



Chip Selects and Wait States

The eZ80L92 generates four Chip Selects for external devices. Each Chip Select may be programmed to access either memory space or I/O space. The Memory Chip Selects can be individually programmed on a 64KB boundary. The I/O Chip Selects can each choose a 256-byte section of I/O space. In addition, each Chip Select may be programmed for up to 7 wait states.

Memory and I/O Chip Selects

Each of the Chip Selects can be enabled for either the memory address space or the I/O address space, but not both. To select the memory address space for a particular Chip Select, CSx_IO (CSx_CTL[4]) must be reset to 0. To select the I/O address space for a particular Chip Select, CSx_IO must be set to 1. After RESET, the default is for all Chip Selects to be configured for the memory address space. For either the memory address space or the I/O address space, the individual Chip Selects must be enabled by setting CSx_EN (CSx_CTL[3]) to 1.

Memory Chip Select Operation

Operation of each of the Memory Chip Selects is controlled by three control registers. To enable a particular Memory Chip Select, the following conditions must be met:

- The Chip Select is enabled by setting CSx_EN to 1
- The Chip Select is configured for Memory by clearing CSx_IO to 0
- The address is in the associated Chip Select range:

$$CSx_LBR[7:0] \leq ADDR[23:16] \leq CSx_UBR[7:0]$$
- No higher priority (lower number) Chip Select meets the above conditions
- A memory access instruction must be executing

If all of the foregoing conditions are met to generate a Memory Chip Select, then the following actions occur:

- The appropriate Chip Select— $\overline{CS0}$, $\overline{CS1}$, $\overline{CS2}$, or $\overline{CS3}$ —is asserted (driven Low)
- \overline{MREQ} is asserted (driven Low)
- Depending upon the instruction, either \overline{RD} or \overline{WR} is asserted (driven Low)

If the upper and lower bounds are set to the same value (CSx_UBR = CSx_LBR), then a particular Chip Select is valid for a single 64KB page.



Memory Chip Select Priority

A lower-numbered Chip Select is granted priority over a higher-numbered Chip Select. For example, if the address space of Chip Select 0 overlaps the Chip Select 1 address space, Chip Select 0 is active.

RESET States

On RESET, Chip Select 0 is active for all addresses, because its Lower Bound register resets to 00h and its Upper Bound register resets to FFh. All of the other Chip Select Lower and Upper Bound registers reset to 00h.

Memory Chip Select Example

The use of Memory Chip Selects is demonstrated in Figure 4. The associated control register values indicated in Table 13. In this example, all 4 Chip Selects are enabled and configured for memory addresses. Also, CS1 overlaps with CS0. Because CS0 is prioritized higher than CS1, CS1 is not active for much of its defined address space.

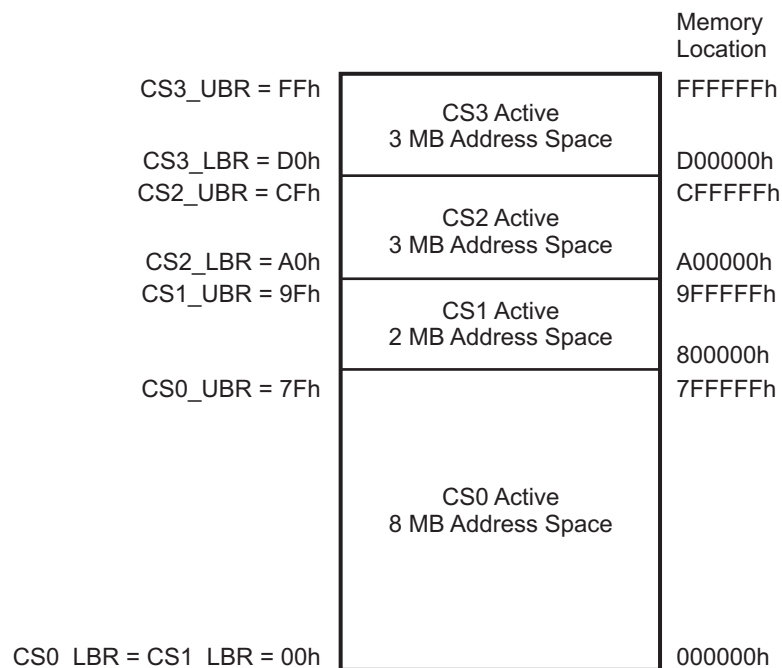

Figure 4. Memory Chip Select Example



Table 13. Register Values for Memory Chip Select Example in Figure 4

| Chip Select | CSx_CTL[3] | CSx_CTL[4] | CSx_LBR | CSx_UBR | Description |
|-------------|------------|------------|---------|---------|--|
| | CSx_EN | CSx_IO | | | |
| CS0 | 1 | 0 | 00h | 7Fh | CS0 is enabled as a Memory Chip Select. Valid addresses range from 000000h–7FFFFFFh. |
| CS1 | 1 | 0 | 00h | 9Fh | CS1 is enabled as a Memory Chip Select. Valid addresses range from 800000h–9FFFFFFh. |
| CS2 | 1 | 0 | A0h | CFh | CS2 is enabled as a Memory Chip Select. Valid addresses range from A00000h–CFFFFFFh. |
| CS3 | 1 | 0 | D0h | FFh | CS3 is enabled as a Memory Chip Select. Valid addresses range from D00000h–FFFFFFh. |

I/O Chip Select Operation

I/O Chip Selects can only be active when the CPU is performing I/O instructions. Because the I/O space is separate from the memory space in the eZ80L92 device, there can never be a conflict between I/O and memory addresses.

The eZ80L92 supports a 16-bit I/O address. The I/O Chip Select logic decodes the High byte of the I/O address, ADDR[15:8]. Because the upper byte of the address bus, ADDR[23:16], is ignored, the I/O devices can always be accessed from within any memory mode (ADL or Z80). The MBASE offset value used for setting the Z80 MEMORY mode page is also always ignored.

Four I/O Chip Selects are available with the eZ80L92. To generate a particular I/O Chip Select, the following conditions must be met:

- The Chip Select is enabled by setting CSX_EN to 1
- The Chip Select is configured for I/O by setting CSx_IO to 1
- An I/O Chip Select address match occurs—ADDR[15:8] = CSx_LBR[7:0]
- No higher-priority (lower-number) Chip Select meets the above conditions
- The I/O address is not within the on-chip peripheral address range 0080h–00FFh. On-chip peripheral registers assume priority for all addresses where:

$$0080h \leq ADDR[15:0] \leq 00FFh$$
- An I/O instruction must be executing

If all of the foregoing conditions are met to generate an I/O Chip Select, then the following actions occur:

- The appropriate Chip Select— $\overline{CS0}$, $\overline{CS1}$, $\overline{CS2}$, or $\overline{CS3}$ —is asserted (driven Low)
- \overline{IORQ} is asserted (driven Low)
- Depending upon the instruction, either \overline{RD} or \overline{WR} is asserted (driven Low)

WAIT States

For each of the Chip Selects, programmable WAIT states can be asserted to provide external devices with additional clock cycles to complete their Read or Write operations. The number of WAIT states for a particular Chip Select is controlled by the 3-bit field CSx_WAIT ($CSx_CTL[7:5]$). The WAIT states can be independently programmed to provide 0 to 7 WAIT states for each Chip Select. The WAIT states idle the CPU for the specified number of system clock cycles.

WAIT Input Signal

Similar to the programmable WAIT states, an external peripheral can drive the WAIT input pin to force the CPU to provide additional clock cycles to complete its Read or Write operation. Driving the WAIT pin Low stalls the CPU. The CPU resumes operation on the first rising edge of the internal system clock following deassertion of the WAIT pin.



Caution: If the WAIT pin is to be driven by an external device, the corresponding Chip Select for the device must be programmed to provide at least one WAIT state. Due to input sampling of the WAIT input pin (shown in Figure 5), one programmable WAIT state is required to allow the external peripheral sufficient time to assert the WAIT pin. It is recommended that the corresponding Chip Select for the external device be programmed to provide the maximum number of WAIT states (seven).

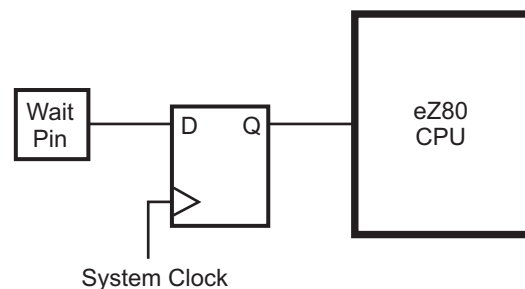

Figure 5. Wait Input Sampling Block Diagram

An example of WAIT state operation is illustrated in Figure 6. In this example, the Chip Select is configured to provide a single WAIT state. The external peripheral being accessed drives the WAIT pin Low to request assertion of an additional WAIT state. If the WAIT pin is asserted for additional system clock cycles, WAIT states are added until the WAIT pin is deasserted (High).

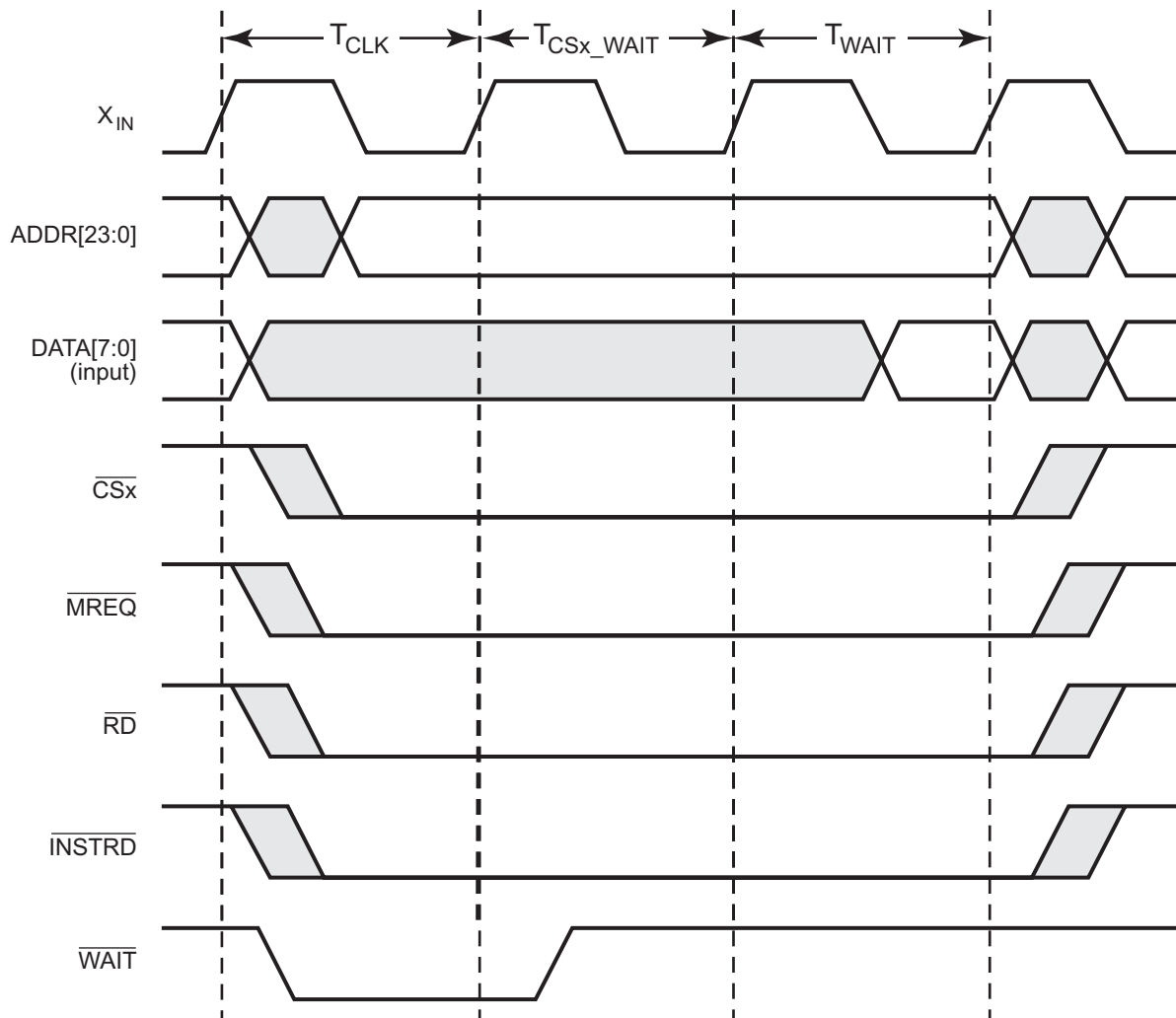

Figure 6. Wait State Operation Example (Read Operation)

Chip Selects During Bus Request/Bus Acknowledge Cycles

When the CPU relinquishes the address bus to an external peripheral in response to an external bus request (BUSREQ), it drives the bus acknowledge pin (BUSACK) Low. The external peripheral can then drive the address bus (and data



bus). The CPU continues to generate Chip Select signals in response to the address on the bus. External devices cannot access the internal registers of the eZ80L92.

Bus Mode Controller

The bus mode controller allows the address and data bus timing and signal formats of the eZ80L92 to be configured to connect seamlessly with external eZ80[®], Z80-, Intel-, or Motorola-compatible devices. Bus modes for each of the chip selects can be configured independently using the Chip Select Bus Mode Control Registers. The number of eZ80[®] system clock cycles per bus mode state is also independently programmable. For Intel bus mode, multiplexed address and data can be selected in which the lower byte of the address and the data byte both use the data bus, DATA[7:0]. Each of the bus modes is explained in more detail in the following sections.

eZ80 Bus Mode

Chip selects configured for eZ80 Bus Mode do not modify the bus signals from the CPU. The timing diagrams for external Memory and I/O Read and Write operations are shown in the [AC Characteristics](#) section on page 204. The default mode for each chip select is eZ80 mode.

Z80 Bus Mode

Chip selects configured for Z80 mode modify the eZ80[®] bus signals to match the Z80 microprocessor address and data bus interface signal format and timing. During Read operations, the Z80 Bus Mode employs three states (T1, T2, and T3) as described in Table 14.

Table 14. Z80 Bus Mode Read States

| | |
|----------|--|
| STATE T1 | The READ cycle begins in State T1. The CPU drives the address onto the address bus and the associated Chip Select signal is asserted. |
| STATE T2 | <u>During State T2</u> , the RD signal is asserted. <u>Depending</u> upon the instruction, either the MREQ or IORQ signal is asserted. If the external WAIT pin is driven Low at least one eZ80 [®] system <u>clock cycle</u> prior to the end of State T2, additional WAIT states (T_{WAIT}) are asserted until the WAIT pin is driven High. |
| STATE T3 | During State T3, no bus signals are altered. The data is latched by the eZ80L92 at the rising edge of the eZ80 [®] system clock at the end of State T3. |

During Write operations, Z80 Bus Mode employs 3 states (T1, T2, and T3) as described in Table 15.



Table 15. Z80 Bus Mode Write States

| | |
|----------|--|
| STATE T1 | The WRITE cycle begins in State T1. The CPU drives the address onto the address bus, the associated Chip Select signal is asserted. |
| STATE T2 | During State T2, the WR signal is asserted. Depending upon the instruction, either the MREQ or IORQ signal is asserted. If the external WAIT pin is driven Low at least one eZ80 [®] system clock cycle prior to the end of State T2, additional WAIT states (T _{WAIT}) are asserted until the WAIT pin is driven High. |
| STATE T3 | During State T3, no bus signals are altered. |

Z80 Bus Mode Read and Write timing is illustrated in Figures 7 and 8. The Z80 Bus Mode states can be configured for 1 to 15 eZ80[®] system clock cycles. In the figures, each Z80 Bus Mode state is two eZ80[®] system clock cycles in duration. Figures 7 and 8 also illustrate the assertion of 1 WAIT state (T_{WAIT}) by the external peripheral during each Z80 Bus Mode cycle.

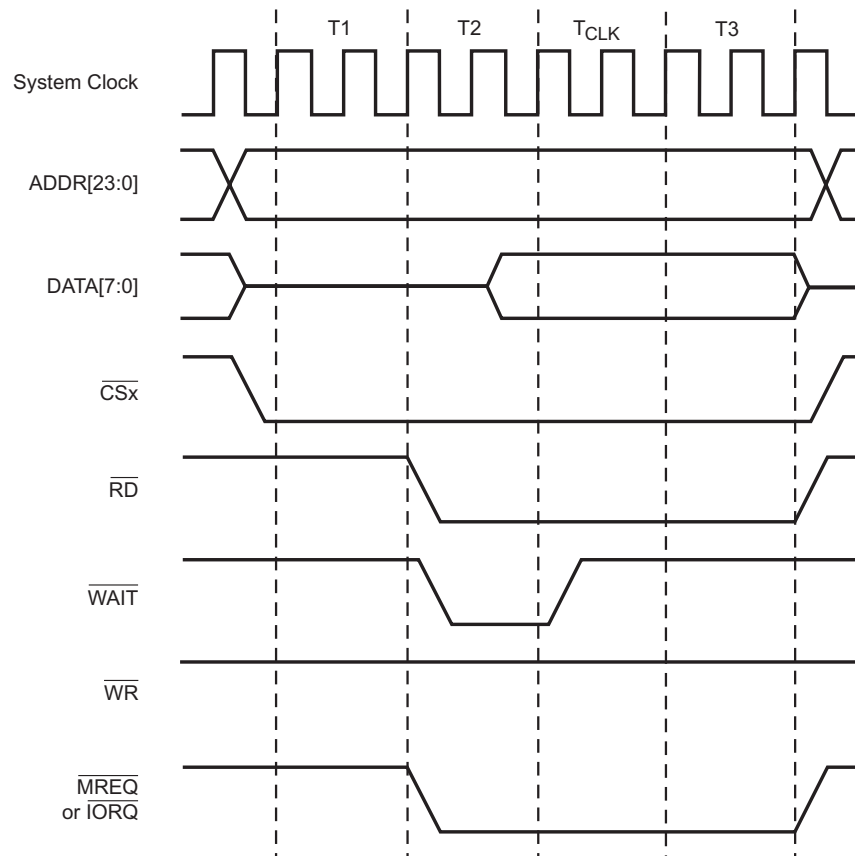

Figure 7. Z80 Bus Mode Read Timing Example

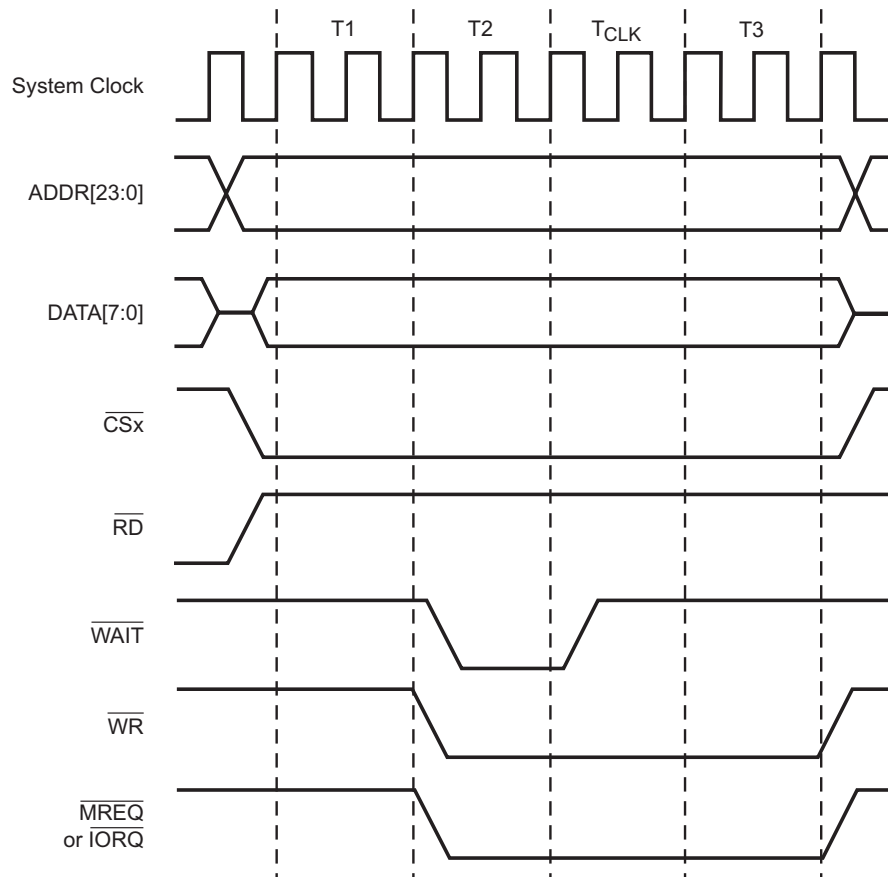

Figure 8. Z80 Bus Mode Write Timing Example

Intel Bus Mode

Chip selects configured for Intel Bus Mode modify the eZ80[®] bus signals to duplicate a four-state memory transfer similar to that found on Intel-style microprocessors. The bus signals and eZ80L92 pins are mapped as illustrated in Figure 9. In Intel Bus Mode, the user can select either multiplexed or nonmultiplexed address and data buses. In nonmultiplexed operation, the address and data buses are separate. In multiplexed operation, the lower byte of the address, ADDR[7:0], also appears on the data bus, DATA[7:0], during State T1 of the Intel Bus Mode cycle. During multiplexed operation, the lower byte of the address bus also appears on the address bus in addition to the data bus.

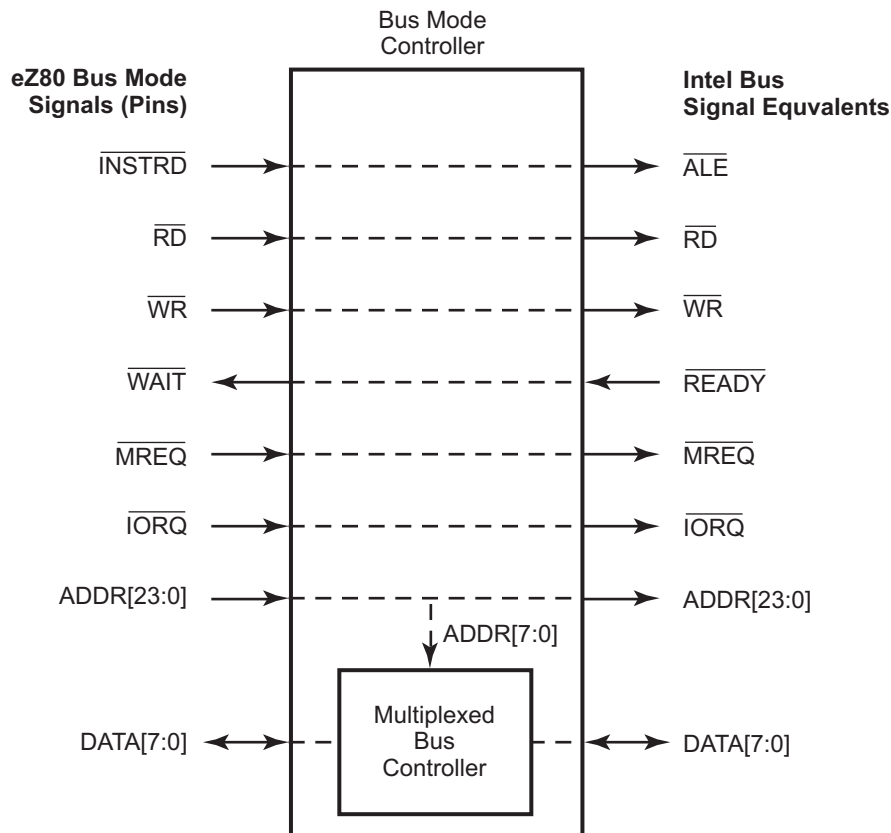

Figure 9. Intel™ Bus Mode Signal and Pin Mapping

Intel Bus Mode (Separate Address and Data Buses)

During Read operations with separate address and data buses, the Intel Bus Mode employs 4 states (T1, T2, T3, and T4) as described in Table 16.

Table 16. Intel™ Bus Mode READ States (Separate Address and Data Buses)

| | |
|----------|---|
| STATE T1 | The Read cycle begins in State T1. The CPU drives the address onto the address bus and the associated Chip Select signal is asserted. The CPU drives the ALE signal High at the beginning of T1. During the middle of T1, the CPU drives ALE Low to facilitate the latching of the address. |
| STATE T2 | During State T2, the CPU asserts the \overline{RD} signal. Depending on the instruction, either the MREQ or IORQ signal is asserted. |

**Table 16. Intel™ Bus Mode READ States (Separate Address and Data Buses) (Continued)**

| | |
|----------|--|
| STATE T3 | During State T3, no bus signals are altered. If the external ReadY (WAIT) pin is driven Low at least one eZ80® system clock cycle prior to the beginning of State T3, additional WAIT states (T_{WAIT}) are asserted until the ReadY pin is driven High. |
| STATE T4 | The CPU latches the Read data at the beginning of State T4. The CPU deasserts the RD signal and completes the Intel Bus Mode cycle. |

During Write operations with separate address and data buses, the Intel Bus Mode employs 4 states (T1, T2, T3, and T4) as described in Table 17.

Table 17. Intel™ Bus Mode WRITE States (Separate Address and Data Buses)

| | |
|----------|---|
| STATE T1 | The Write cycle begins in State T1. The CPU drives the address onto the address bus, the associated Chip Select signal is asserted, and the data is driven onto the data bus. The CPU drives the ALE signal High at the beginning of T1. During the middle of T1, the CPU drives ALE Low to facilitate the latching of the address. |
| STATE T2 | During State T2, the CPU asserts the WR signal. Depending on the instruction, either the MREQ or IORQ signal is asserted. |
| STATE T3 | During State T3, no bus signals are altered. If the external ReadY (WAIT) pin is driven Low at least one eZ80® system clock cycle prior to the beginning of State T3, additional WAIT states (T_{WAIT}) are asserted until the ReadY pin is driven High. |
| STATE T4 | The CPU deasserts the WR signal at the beginning of State T4. The CPU holds the data and address buses through the end of T4. The bus cycle is completed at the end of T4. |

Intel Bus Mode timing is illustrated for a Read operation in Figure 10 and for a Write operation in Figure 11. If the ReadY signal (external WAIT pin) is driven Low prior to the beginning of State T3, additional WAIT states (T_{WAIT}) are asserted until the ReadY signal is driven High. The Intel Bus Mode states can be configured for 2 to 15 eZ80® system clock cycles. In the figures, each Intel™ Bus Mode state is 2 eZ80® system clock cycles in duration. Figures 10 and 11 also illustrate the assertion of one WAIT state (T_{WAIT}) by the selected peripheral.

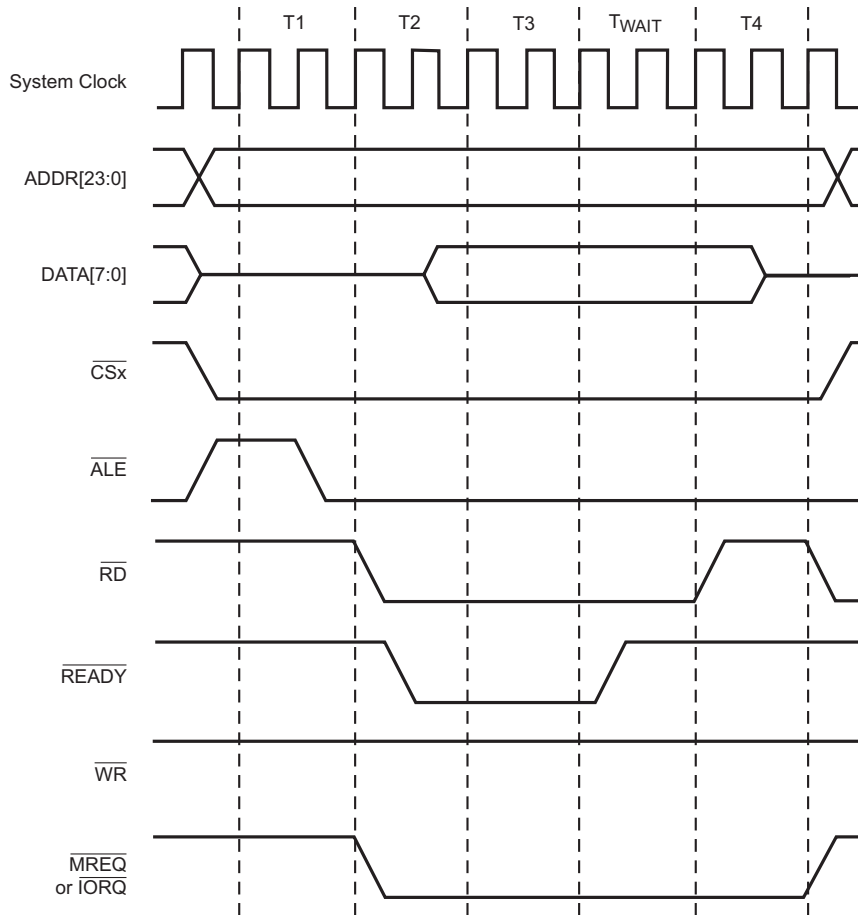

Figure 10. Intel™ Bus Mode Read Timing Example (Separate Address and Data Buses)

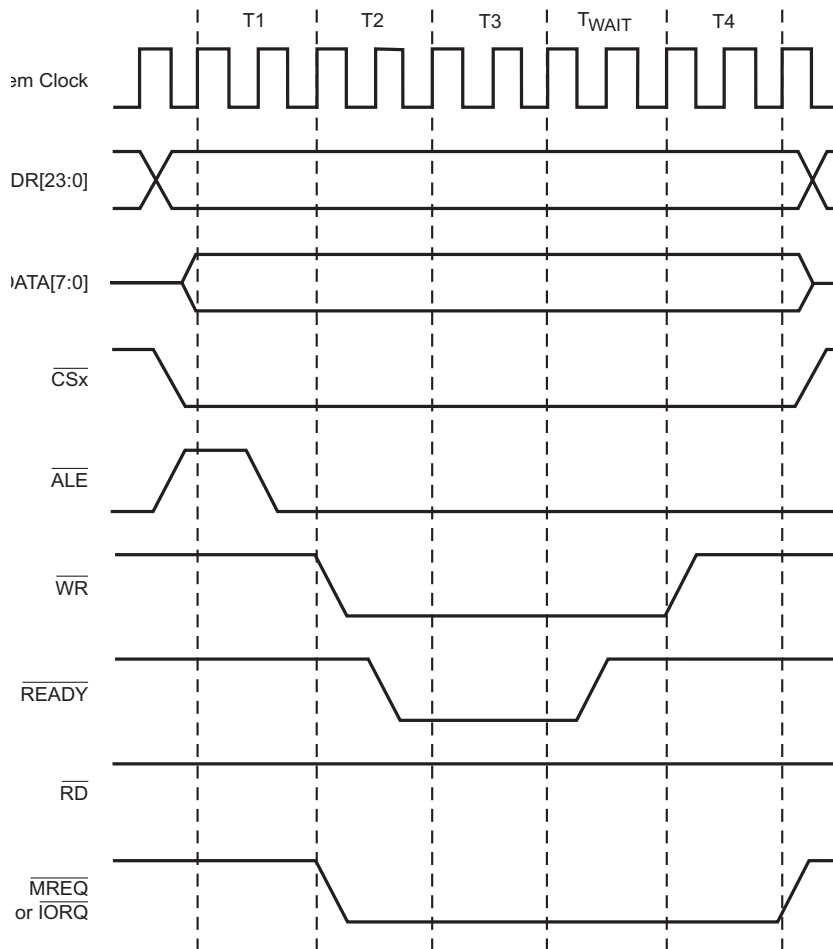

Figure 11. Intel™ Bus Mode Write Timing Example (Separate Address and Data Buses)

Intel™ Bus Mode (Multiplexed Address and Data Bus)

During Read operations with multiplexed address and data, the Intel™ Bus Mode employs 4 states (T1, T2, T3, and T4) as described in Table 18.

**Table 18. Intel™ Bus Mode READ States (Multiplexed Address and Data Bus)**

| | |
|----------|--|
| STATE T1 | The Read cycle begins in State T1. The CPU drives the address onto the DATA bus and the associated Chip Select signal is asserted. The CPU drives the ALE signal High at the beginning of T1. During the middle of T1, the CPU drives ALE Low to facilitate the latching of the address. |
| STATE T2 | During State T2, the CPU removes the address from the DATA bus and asserts the RD signal. Depending upon the instruction, either the MREQ or IORQ signal is asserted. |
| STATE T3 | During State T3, no bus signals are altered. If the external ReadY (WAIT) pin is driven Low at least one eZ80® system clock cycle prior to the beginning of State T3, additional WAIT states (T_{WAIT}) are asserted until the ReadY pin is driven High. |
| STATE T4 | The CPU latches the Read data at the beginning of State T4. The CPU deasserts the RD signal and completes the Intel™ Bus Mode cycle. |

During Write operations with multiplexed address and data, the Intel™ Bus Mode employs 4 states (T1, T2, T3, and T4) as described in Table 19.

Table 19. Intel™ Bus Mode WRITE States (Multiplexed Address and Data Bus)

| | |
|----------|--|
| STATE T1 | The Write cycle begins in State T1. The CPU drives the address onto the DATA bus and drives the ALE signal High at the beginning of T1. During the middle of T1, the CPU drives ALE Low to facilitate the latching of the address. |
| STATE T2 | During State T2, the CPU removes the address from the DATA bus and drives the Write data onto the DATA bus. The WR signal is asserted to indicate a Write operation. |
| STATE T3 | During State T3, no bus signals are altered. If the external ReadY (WAIT) pin is driven Low at least one eZ80® system clock cycle prior to the beginning of State T3, additional WAIT states (T_{WAIT}) are asserted until the ReadY pin is driven High. |
| STATE T4 | The CPU deasserts the Write signal at the beginning of T4 identifying the end of the Write operation. The CPU holds the data and address buses through the end of T4. The bus cycle is completed at the end of T4. |

Signal timing for Intel™ Bus Mode with multiplexed address and data is illustrated for a Read operation in Figure 12 and for a Write operation in Figure 13. In the figures, each Intel™ Bus Mode state is 2 eZ80® system clock cycles in duration. Figures 12 and 13 also illustrate the assertion of one WAIT state (T_{WAIT}) by the selected peripheral.

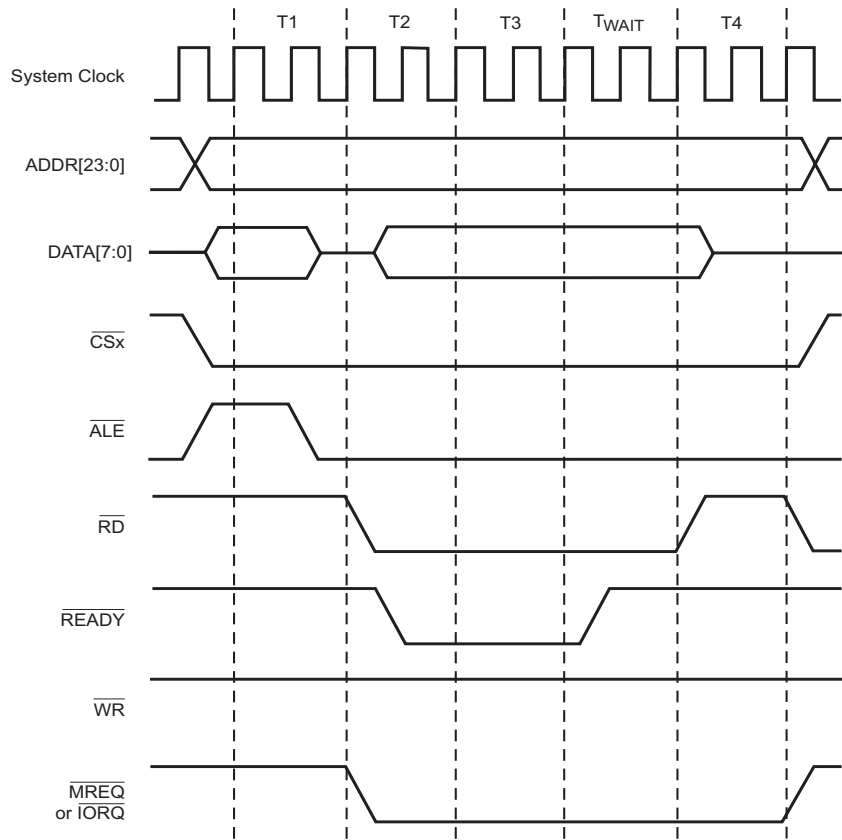

Figure 12. Intel™ Bus Mode Read Timing Example (Multiplexed Address and Data Bus)

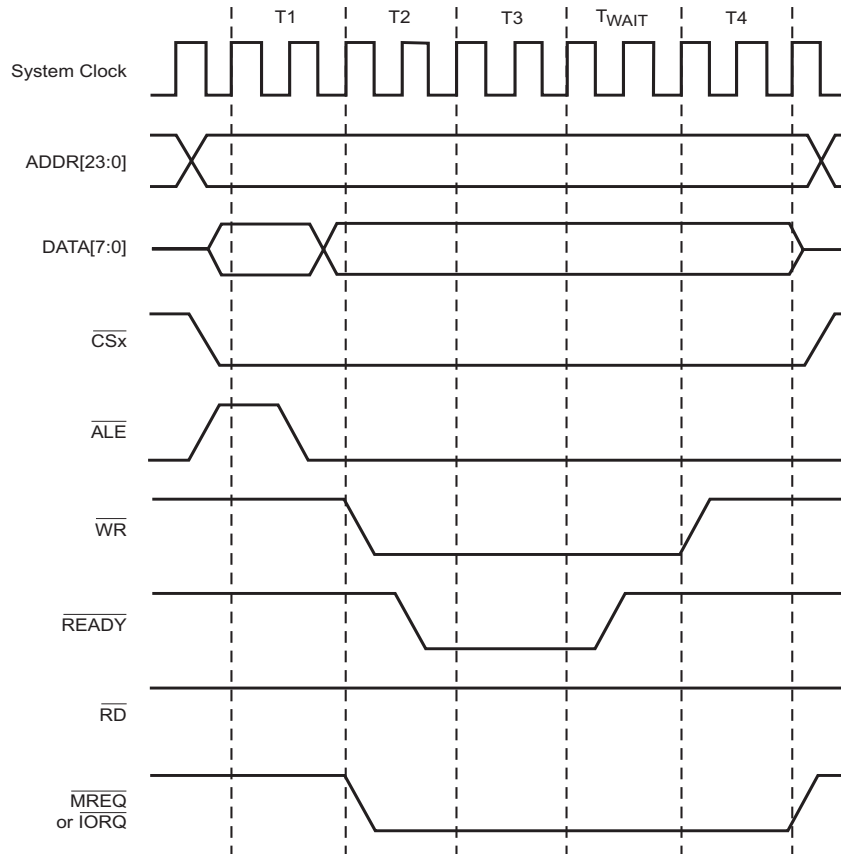

Figure 13. Intel™ Bus Mode Write Timing Example (Multiplexed Address and Data Bus)

Motorola Bus Mode

Chip selects configured for Motorola Bus Mode modify the eZ80® bus signals to duplicate an eight-state memory transfer similar to that found on Motorola-style microprocessors. The bus signals (and eZ80L92 I/O pins) are mapped as illustrated in Figure 14.

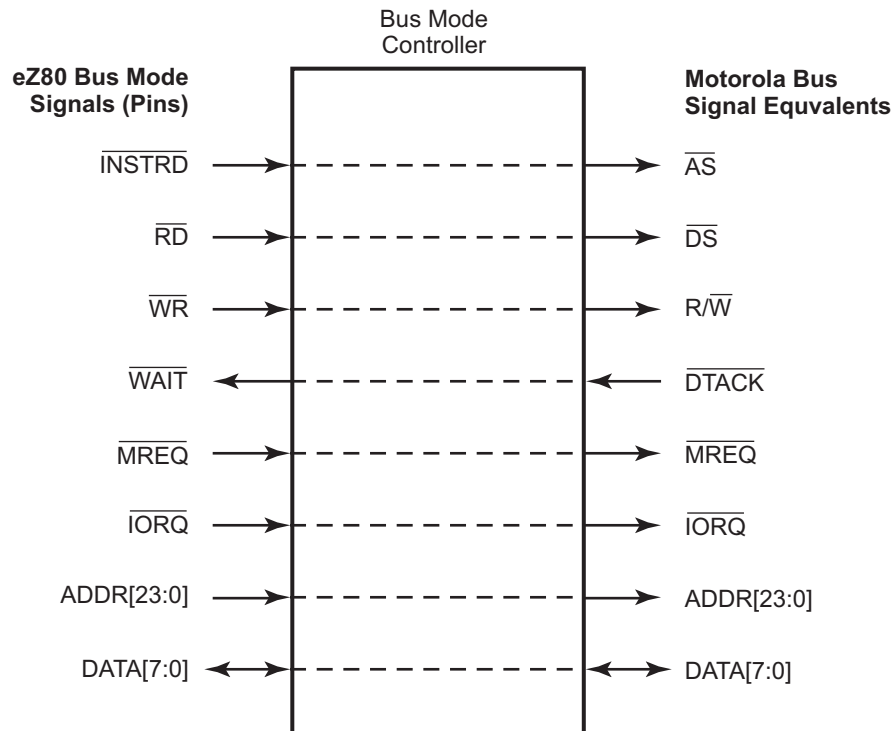

Figure 14. Motorola Bus Mode Signal and Pin Mapping

During Write operations, the Motorola Bus Mode employs 8 states (S0, S1, S2, S3, S4, S5, S6, and S7) as described in Table 20.

Table 20. Motorola Bus Mode Read States

| | |
|----------|---|
| STATE S0 | The READ cycle starts in state S0. The CPU drives $\overline{\text{R}/\overline{\text{W}}}$ High to identify a READ cycle. |
| STATE S1 | Entering state S1, the CPU drives a valid address on the address bus, ADDR[23:0]. |
| STATE S2 | On the rising edge of state S2, the CPU asserts $\overline{\text{AS}}$ and $\overline{\text{DS}}$. |
| STATE S3 | During state S3, no bus signals are altered. |
| STATE S4 | During state S4, the CPU waits for a cycle termination signal $\overline{\text{DTACK}}$ ($\overline{\text{WAIT}}$), a peripheral signal. If the termination signal is not asserted at least one full CPU clock period prior to the rising clock edge at the end of S4, the CPU inserts $\overline{\text{WAIT}}$ (T_{WAIT}) states until $\overline{\text{DTACK}}$ is asserted. Each $\overline{\text{WAIT}}$ state is a full bus mode cycle. |
| STATE S5 | During state S5, no bus signals are altered. |

**Table 20. Motorola Bus Mode Read States (Continued)**

| | |
|----------|---|
| STATE S6 | During state S6, data from the external peripheral device is driven onto the data bus. |
| STATE S7 | On the rising edge of the clock entering state S7, the CPU latches data from the addressed peripheral device and deasserts AS and DS. The peripheral device deasserts DTACK at this time. |

The eight states for a Write operation in Motorola Bus Mode are described in Table 21.

Table 21. Motorola Bus Mode WRITE States

| | |
|----------|--|
| STATE S0 | The Write cycle starts in S0. The CPU drives R/W High (if a preceding Write cycle leaves R/W Low). |
| STATE S1 | Entering S1, the CPU drives a valid address on the address bus. |
| STATE S2 | On the rising edge of S2, the CPU asserts AS and drives R/W Low. |
| STATE S3 | During S3, the data bus is driven out of the high-impedance state as the data to be written is placed on the bus. |
| STATE S4 | At the rising edge of S4, the CPU asserts DS. The CPU waits for a cycle termination signal DTACK (WAIT). If the termination signal is not asserted at least one full CPU clock period prior to the rising clock edge at the end of S4, the CPU inserts WAIT (T_{WAIT}) states until DTACK is asserted. Each WAIT state is a full bus mode cycle. |
| STATE S5 | During S5, no bus signals are altered. |
| STATE S6 | During S6, no bus signals are altered. |
| STATE S7 | Upon entering S7, the CPU deasserts AS and DS. As the clock rises at the end of S7, the CPU drives R/W High. The peripheral device deasserts DTACK at this time. |

Signal timing for Motorola Bus Mode is illustrated for a Read operation in Figure 15 and for a Write operation in Figure 16. In these two figures, each Motorola Bus Mode state is 2 eZ80[®] system clock cycles in duration.

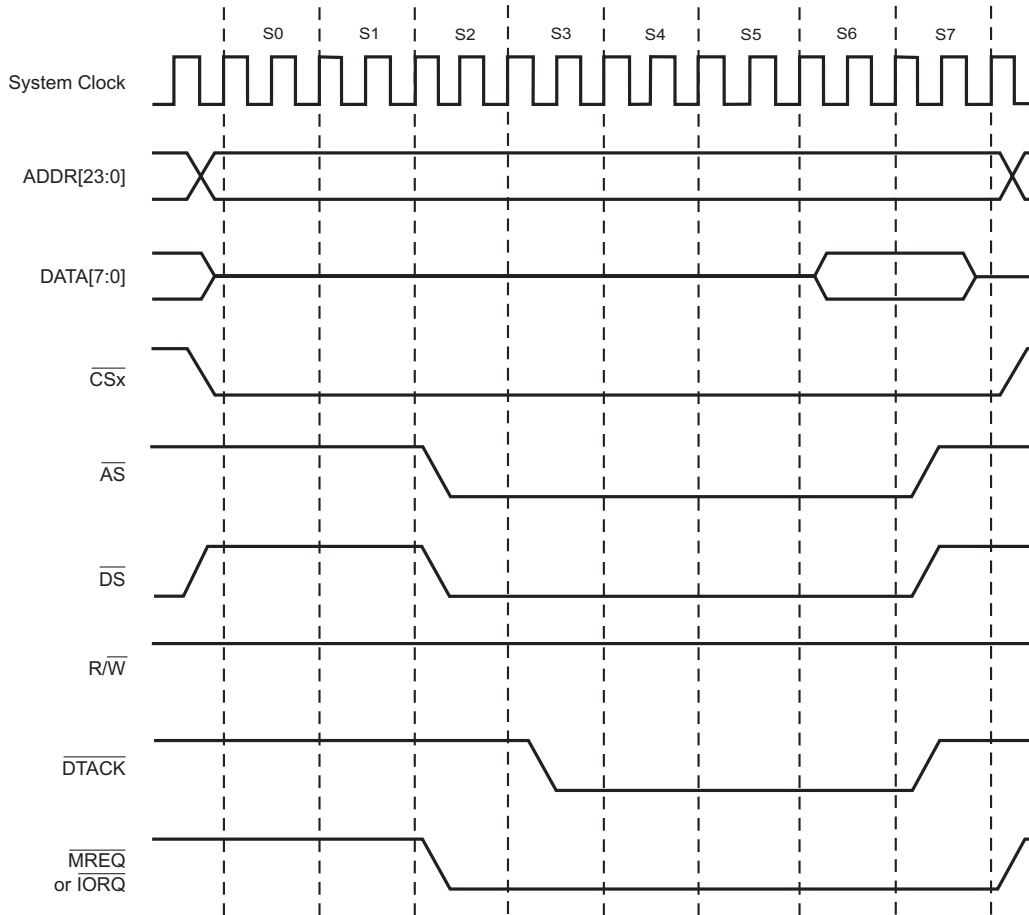

Figure 15. Motorola Bus Mode Read Timing Example

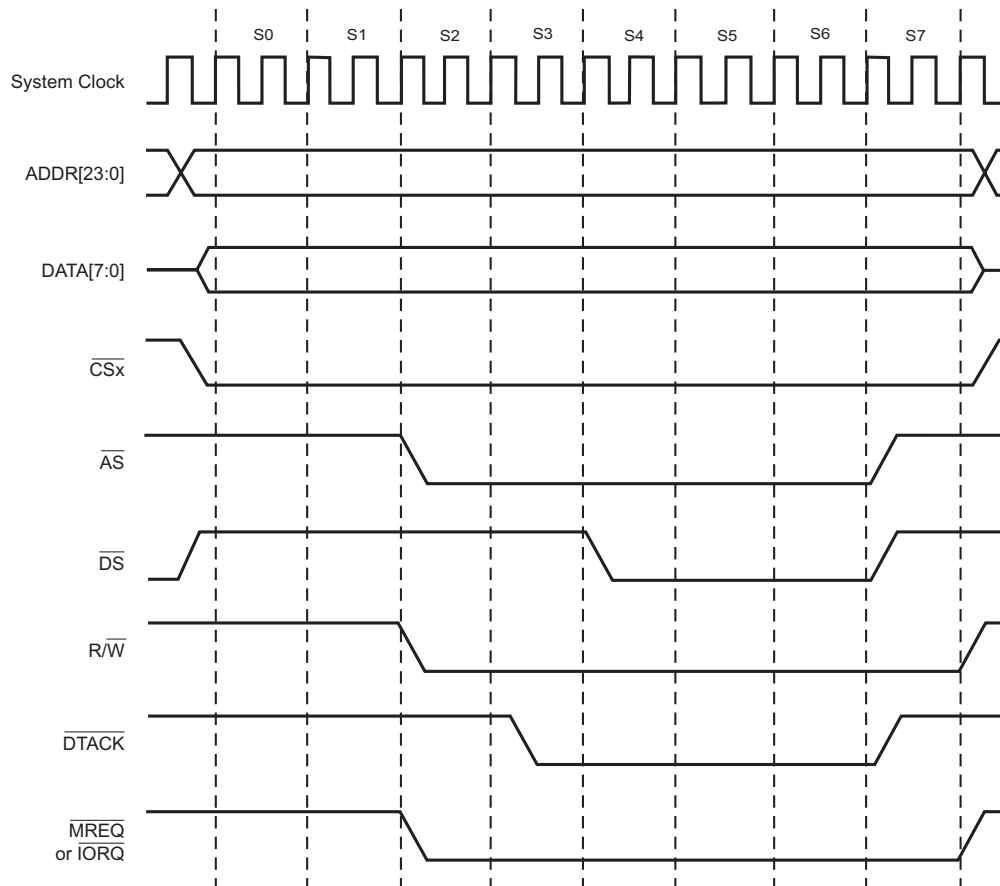

Figure 16. Motorola Bus Mode Write Timing Example

Switching Between Bus Modes

Each time the bus mode controller must switch from one bus mode to another, there is a one-cycle eZ80[®] system clock delay. An extra clock cycle is not required for repeated accesses in any of the bus modes; nor is it required when the eZ80L92 switches to eZ80 Bus Mode. The extra clock cycles are not shown in the timing examples. Due to the asynchronous nature of these bus protocols, the extra delay does not impact peripheral communication.

Chip Select Registers

Chip Select x Lower Bound Registers

For Memory Chip Selects, the Chip Select x Lower Bound register, detailed in Table 22, defines the lower bound of the address range for which the correspond-



ing Memory Chip Select (if enabled) can be active. For I/O Chip Selects, this register defines the address to which ADDR[15:8] is compared to generate an I/O Chip Select. All Chip Select lower bound registers reset to 00h.

Table 22. Chip Select x Lower Bound Registers
(CS0_LBR = 00A8h, CS1_LBR = 00ABh, CS2_LBR = 00AEh, CS3_LBR = 00B1h)

| Bit | 7 | 6 | 5 | 4 | 3 | 2 | 1 | 0 |
|---------------|-----|-----|-----|-----|-----|-----|-----|-----|
| CS0_LBR Reset | 0 | 0 | 0 | 0 | 0 | 0 | 0 | 0 |
| CS1_LBR Reset | 0 | 0 | 0 | 0 | 0 | 0 | 0 | 0 |
| CS2_LBR Reset | 0 | 0 | 0 | 0 | 0 | 0 | 0 | 0 |
| CS3_LBR Reset | 0 | 0 | 0 | 0 | 0 | 0 | 0 | 0 |
| CPU Access | R/W | R/W | R/W | R/W | R/W | R/W | R/W | R/W |

Note: R/W = Read/Write.

| Bit Position | Value | Description |
|--------------|-------|---|
| [7:0] | 00h– | For Memory Chip Selects (CSx_IO = 0) |
| CSx_LBR | FFh | This byte specifies the lower bound of the Chip Select address range. The upper byte of the address bus, ADDR[23:16], is compared to the values contained in these registers for determining whether a Memory Chip Select signal should be generated. |
| | | For I/O Chip Selects (CSx_IO = 1) |
| | | This byte specifies the Chip Select address value. ADDR[15:8] is compared to the values contained in these registers for determining whether an I/O Chip Select signal should be generated. |



Chip Select x Upper Bound Registers

For Memory Chip Selects, the Chip Select x Upper Bound registers, detailed in Table 23, defines the upper bound of the address range for which the corresponding Chip Select (if enabled) can be active. For I/O Chip Selects, this register produces no effect. The reset state for the Chip Select 0 Upper Bound register is FFh, while the reset state for the other Chip Select upper bound registers is 00h.

Table 23. Chip Select x Upper Bound Registers
(CS0_UBR = 00A9h, CS1_UBR = 00ACh, CS2_UBR = 00AFh, CS3_UBR = 00B2h)

| Bit | 7 | 6 | 5 | 4 | 3 | 2 | 1 | 0 |
|---------------|-----|-----|-----|-----|-----|-----|-----|-----|
| CS0_UBR Reset | 1 | 1 | 1 | 1 | 1 | 1 | 1 | 1 |
| CS1_UBR Reset | 0 | 0 | 0 | 0 | 0 | 0 | 0 | 0 |
| CS2_UBR Reset | 0 | 0 | 0 | 0 | 0 | 0 | 0 | 0 |
| CS3_UBR Reset | 0 | 0 | 0 | 0 | 0 | 0 | 0 | 0 |
| CPU Access | R/W | R/W | R/W | R/W | R/W | R/W | R/W | R/W |

Note: R/W = Read/Write.

| Bit Position | Value | Description |
|------------------|-------------|--|
| [7:0] CSx_UBR | 00h– FFh | <p>For Memory Chip Selects (CSx_IO = 0) This byte specifies the upper bound of the Chip Select address range. The upper byte of the address bus, ADDR[23:16], is compared to the values contained in these registers for determining whether a Chip Select signal should be generated.</p> <hr/> <p>For I/O Chip Selects (CSx_IO = 1) No effect.</p> |



Chip Select x Control Registers

The Chip Select x Control register, detailed in Table 24, enables the Chip Selects, specifies the type of Chip Select, and sets the number of WAIT states. The reset state for the Chip Select 0 Control register is $E8h$, while the reset state for the 3 other Chip Select control registers is $00h$.

Table 24. Chip Select x Control Registers
(CS0_CTL = 00AAh, CS1_CTL = 00ADh, CS2_CTL = 00B0h, CS3_CTL = 00B3h)

| Bit | 7 | 6 | 5 | 4 | 3 | 2 | 1 | 0 |
|---------------|-----|-----|-----|-----|-----|---|---|---|
| CS0_CTL Reset | 1 | 1 | 1 | 0 | 1 | 0 | 0 | 0 |
| CS1_CTL Reset | 0 | 0 | 0 | 0 | 0 | 0 | 0 | 0 |
| CS2_CTL Reset | 0 | 0 | 0 | 0 | 0 | 0 | 0 | 0 |
| CS3_CTL Reset | 0 | 0 | 0 | 0 | 0 | 0 | 0 | 0 |
| CPU Access | R/W | R/W | R/W | R/W | R/W | R | R | R |

Note: R/W = Read/Write; R = Read Only.

| Bit Position | Value | Description |
|--------------------|-------|---|
| [7:5] CSx_WAIT* | 000 | 0 WAIT states are asserted when this Chip Select is active. |
| | 001 | 1 WAIT state is asserted when this Chip Select is active. |
| | 010 | 2 WAIT states are asserted when this Chip Select is active. |
| | 011 | 3 WAIT states are asserted when this Chip Select is active. |
| | 100 | 4 WAIT states are asserted when this Chip Select is active. |
| | 101 | 5 WAIT states are asserted when this Chip Select is active. |
| | 110 | 6 WAIT states are asserted when this Chip Select is active. |
| | 111 | 7 WAIT states are asserted when this Chip Select is active. |
| 4 CSx_IO | 0 | Chip Select is configured as a Memory Chip Select. |
| | 1 | Chip Select is configured as an I/O Chip Select. |
| 3 CSx_EN | 0 | Chip Select is disabled. |
| | 1 | Chip Select is enabled. |
| [2:0] | 000 | Reserved. |

Note: *These WAIT state settings apply only to the default eZ80 bus mode. See Table 25.



Chip Select x Bus Mode Control Registers

The Chip Select Bus Mode register, detailed in Table 25, configures the Chip Select for eZ80[®], Z80, Intel[™], or Motorola Bus Modes. Changing the bus mode allows the eZ80L92 to interface to peripherals based on the Z80-, Intel[™]-, or Motorola-style asynchronous bus interfaces. When a bus mode other than eZ80[®] is programmed for a particular Chip Select, the CSx_WAIT setting in that Chip Select Control Register is ignored.

Table 25. Chip Select x Bus Mode Control Registers
(CS0_BMC = 00F0h, CS1_BMC = 00F1h, CS2_BMC = 00F2h, CS3_BMC = 00F3h)

| Bit | 7 | 6 | 5 | 4 | 3 | 2 | 1 | 0 |
|---------------|-----|-----|-----|---|-----|-----|-----|-----|
| CS0_BMC Reset | 0 | 0 | 0 | 0 | 0 | 0 | 1 | 0 |
| CS1_BMC Reset | 0 | 0 | 0 | 0 | 0 | 0 | 1 | 0 |
| CS2_BMC Reset | 0 | 0 | 0 | 0 | 0 | 0 | 1 | 0 |
| CS3_BMC Reset | 0 | 0 | 0 | 0 | 0 | 0 | 1 | 0 |
| CPU Access | R/W | R/W | R/W | R | R/W | R/W | R/W | R/W |

Note: R/W = Read/Write; R = Read Only.

| Bit Position | Value | Description |
|-------------------|-------|---|
| [7:6] BUS_MODE | 00 | eZ80 [®] bus mode. |
| | 01 | Z80 bus mode. |
| | 10 | Intel [™] bus mode. |
| | 11 | Motorola bus mode. |
| 5 AD_MUX | 0 | Separate address and data. |
| | 1 | Multiplexed address and data—appears on data bus DATA[7:0]. |
| 4 | 0 | Reserved. |



| Bit Position | Value | Description |
|--------------|-------|--|
| [3:0] | 0000 | Not valid. |
| BUS_CYCLE | 0001 | Each bus mode state is 1 eZ80 [®] clock cycle in duration. ^{1, 2, 3} |
| | 0010 | Each bus mode state is 2 eZ80 [®] clock cycles in duration. |
| | 0011 | Each bus mode state is 3 eZ80 [®] clock cycles in duration. |
| | 0100 | Each bus mode state is 4 eZ80 [®] clock cycles in duration. |
| | 0101 | Each bus mode state is 5 eZ80 [®] clock cycles in duration. |
| | 0110 | Each bus mode state is 6 eZ80 [®] clock cycles in duration. |
| | 0111 | Each bus mode state is 7 eZ80 [®] clock cycles in duration. |
| | 1000 | Each bus mode state is 8 eZ80 [®] clock cycles in duration. |
| | 1001 | Each bus mode state is 9 eZ80 [®] clock cycles in duration. |
| | 1010 | Each bus mode state is 10 eZ80 [®] clock cycles in duration. |
| | 1011 | Each bus mode state is 11 eZ80 [®] clock cycles in duration. |
| | 1100 | Each bus mode state is 12 eZ80 [®] clock cycles in duration. |
| | 1101 | Each bus mode state is 13 eZ80 [®] clock cycles in duration. |
| | 1110 | Each bus mode state is 14 eZ80 [®] clock cycles in duration. |
| | 1111 | Each bus mode state is 15 eZ80 [®] clock cycles in duration. |

Notes:

1. Setting the BUS_CYCLE to 1 in Intel Bus Mode causes the ALE pin to not function properly.
2. Use of the external WAIT input pin in Z80 Mode requires that BUS_CYCLE is set to a value greater than 1.
3. These BUS_CYCLE values are not valid in eZ80 bus mode. See Table 24.

Watch-Dog Timer

Watch-Dog Timer Overview

The Watch-Dog Timer (WDT) helps protect against corrupt or unreliable software, power faults, and other system-level problems which may place the eZ80[®] CPU into unsuitable operating states. The eZ80L92 WDT features:

- Four programmable time-out periods: 2^{18} , 2^{22} , 2^{25} , and 2^{27} clock cycles
- Two selectable WDT clock sources: the system clock or the Real-Time Clock source (on-chip 32Khz crystal oscillator or 50/60Hz signal)
- A selectable time-out response: a time-out can be configured to generate either a RESET or a nonmaskable interrupt (NMI)
- A WDT time-out RESET indicator flag

Figure 17 illustrates the block diagram for the Watch-Dog Timer.

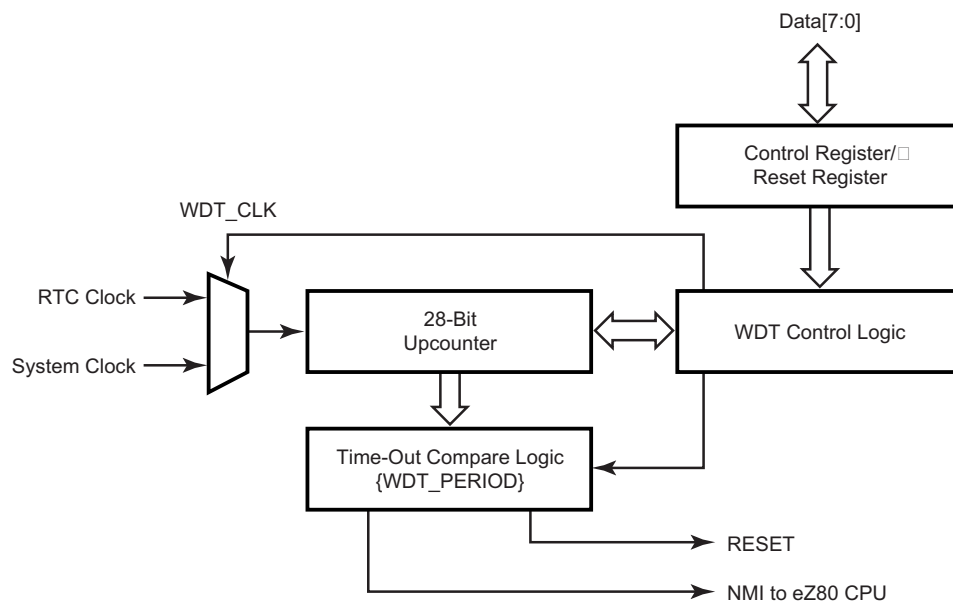

Figure 17. Watch-Dog Timer Block Diagram



Watch-Dog Timer Operation

Enabling and Disabling the WDT

The Watch-Dog Timer is disabled upon a system reset (RESET). To enable the WDT, the application program must set the WDT_EN bit (bit 7) of the WDT_CTL register. When enabled, the WDT cannot be disabled without a RESET.

Time-Out Period Selection

There are four choices of time-out periods for the WDT— 2^{18} , 2^{22} , 2^{25} , and 2^{27} system clock cycles. The WDT time-out period is defined by the WDT_PERIOD field of the WDT_CTL register (WDT_CTL[1:0]). The approximate time-out periods for two different WDT clock sources is listed in Table 26.

Table 26. Watch-Dog Timer Approximate Time-Out Delays

| Clock Source | Divider Value | Time Out Delay |
|------------------------------|---------------|----------------|
| 32.768KHz Crystal Oscillator | 2^{18} | 8.00s |
| 32.768KHz Crystal Oscillator | 2^{22} | 128s |
| 32.768KHz Crystal Oscillator | 2^{25} | 1024s |
| 32.768KHz Crystal Oscillator | 2^{27} | 4096s |
| 20MHz System Clock | 2^{18} | 13.1ms |
| 20MHz System Clock | 2^{22} | 209.7ms |
| 20MHz System Clock | 2^{25} | 1.68s |
| 20MHz System Clock | 2^{27} | 6.71s |
| 50MHz System Clock | 2^{18} | 5.2ms* |
| 50MHz System Clock | 2^{22} | 83.9ms* |
| 50MHz System Clock | 2^{25} | 0.67s |
| 50MHz System Clock | 2^{27} | 2.68s |

RESET Or NMI Generation

Upon a WDT time-out, the RST_FLAG in the WDT_CTL register is set to 1. In addition, the WDT can cause a RESET or send a nonmaskable interrupt (NMI) signal to the CPU. The default operation is for the WDT to cause a RESET. It asserts/deasserts on the rising edge of the clock. The RST_FLAG bit can be polled by the CPU to determine the source of the RESET event.

If the NMI_OUT bit in the WDT_CTL register is set to 1, then upon time-out, the WDT asserts an NMI for CPU processing. The RST_FLAG bit can be polled by



the CPU to determine the source of the NMI event, provided that the last RESET was not caused by the WDT.

Watch-Dog Timer Registers

Watch-Dog Timer Control Register

The Watch-Dog Timer Control register, detailed in Table 27, is an 8-bit Read/Write register used to enable the Watch-Dog Timer, set the time-out period, indicate the source of the most recent RESET, and select the required operation upon WDT time-out.

Table 27. Watch-Dog Timer Control Register (WDT_CTL = 0093h)

| Bit | 7 | 6 | 5 | 4 | 3 | 2 | 1 | 0 |
|------------|-----|-----|-----|-----|-----|---|-----|-----|
| Reset | 0 | 0 | 0/1 | 0 | 0 | 0 | 0 | 0 |
| CPU Access | R/W | R/W | R | R/W | R/W | R | R/W | R/W |

Note: R = Read only; R/W = Read/Write.

| Bit Position | Value | Description |
|------------------|-------|--|
| 7 WDT_EN | 0 | WDT is disabled. |
| | 1 | WDT is enabled. When enabled, the WDT cannot be disabled without a full RESET. |
| 6 NMI_OUT | 0 | WDT time-out resets the CPU. |
| | 1 | WDT time-out generates a nonmaskable interrupt (NMI) to the CPU. |
| 5 RST_FLAG* | 0 | RESET caused by external full-chip reset or ZDI reset. |
| | 1 | RESET caused by WDT time-out. This flag is set by the WDT time-out, even if the NMI_OUT flag is set to 1. The CPU can poll this bit to determine the source of the RESET or NMI. |
| [4:3] WDT_CLK | 00 | WDT clock source is system clock. |
| | 01 | WDT clock source is Real-Time Clock source (32KHz on-chip oscillator or 50/60Hz input as set by RTC_CTRL[4]) . |
| | 10 | Reserved. |
| | 11 | Reserved. |
| 2 RESERVED | 0 | Reserved. |

Note: *RST_FLAG is only cleared by a non-WDT RESET.



| Bit Position | Value | Description |
|--------------|-------|---|
| [1:0] | 00 | WDT time-out period is 2^{27} clock cycles. |
| WDT_PERIOD | 01 | WDT time-out period is 2^{25} clock cycles. |
| | 10 | WDT time-out period is 2^{22} clock cycles. |
| | 11 | WDT time-out period is 2^{18} clock cycles. |

Note: *RST_FLAG is only cleared by a non-WDT RESET.

Watch-Dog Timer Reset Register

The Watch-Dog Timer Reset register, detailed in Table 28, is an 8-bit Write-Only register. The Watch-Dog Timer is reset when an A5h value followed by 5Ah is written to this register. Any amount of time can occur between the writing of the A5h value and the 5Ah value, so long as the WDT time-out does not occur prior to completion.

Table 28. Watch-Dog Timer Reset Register (WDT_RR = 0094h)

| Bit | 7 | 6 | 5 | 4 | 3 | 2 | 1 | 0 |
|-------------------|---|---|---|---|---|---|---|---|
| Reset | X | X | X | X | X | X | X | X |
| CPU Access | W | W | W | W | W | W | W | W |

Note: X = Undefined; W = Write only.

| Bit Position | Value | Description |
|-----------------|-------|--|
| [7:0] WDT_RR | A5h | The first Write value required to reset the WDT prior to a time-out. |
| | 5Ah | The second Write value required to reset the WDT prior to a time-out. If an A5h, 5Ah sequence is written to WDT_RR, the WDT timer is reset to its initial count value, and counting resumes. |

Programmable Reload Timers

Programmable Reload Timers Overview

The eZ80L92 features six Programmable Reload Timers (PRT). Each PRT contains a 16-bit downcounter and a 16-bit reload register. In addition, each PRT features a clock prescaler with four selectable taps for $\text{CLK} \div 4$, $\text{CLK} \div 16$, $\text{CLK} \div 64$, and $\text{CLK} \div 256$. Each timer can be individually enabled to operate in either SINGLE PASS or CONTINUOUS mode. The timer can be programmed to start, stop, restart from the current value, or restart from the initial value, and generate interrupts to the CPU.

Four of the Programmable Reload Timers (timers 0–3) feature a selectable clock source input. The input for these timers can be either the system clock or the Real-Time Clock (RTC) source. Timers 0–3 can also be used for event counting, with their inputs received from a GPIO port pin. Output from timers 4 and 5 can be directed to a GPIO port pin.

Each of the six PRTs available on the eZ80L92 can be controlled individually. They do not share the same counters, reload registers, control registers, or interrupt signals. A simplified block diagram of a programmable reload timer is illustrated in Figure 18.

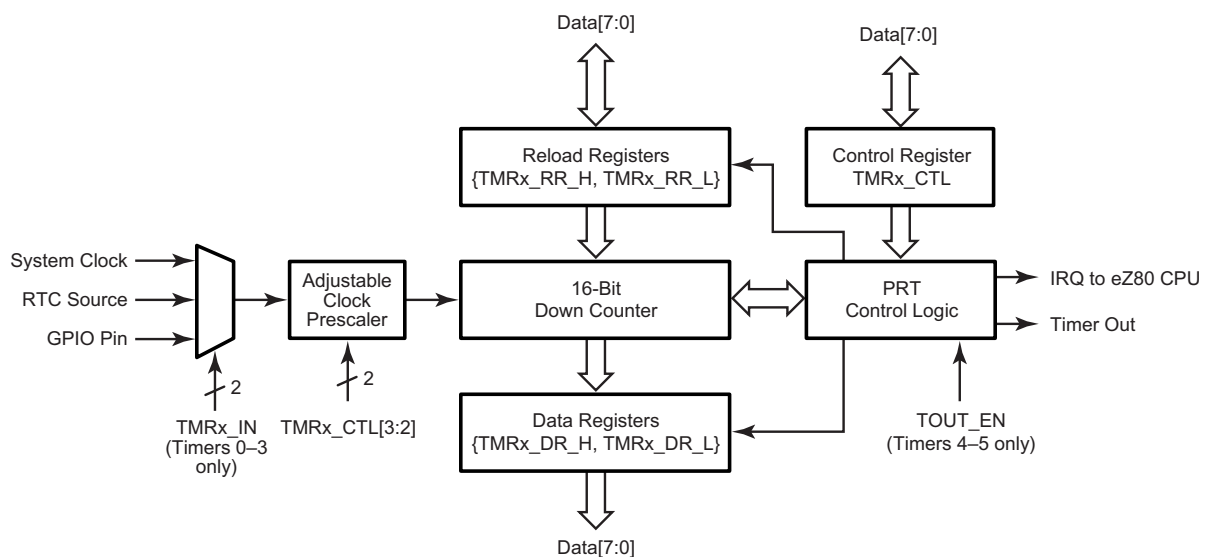

Figure 18. Programmable Reload Timer Block Diagram



Programmable Reload Timer Operation

Setting Timer Duration

There are three factors to consider when determining Programmable Reload Timer duration—clock frequency, clock divider ratio, and initial count value. Minimum duration of the timer is achieved by loading 0001h. Maximum duration is achieved by loading 0000h, because the timer first rolls over to FFFFh and then continues counting down to 0000h.

The time-out period of the PRT is returned by the following equation:

$$\text{PRT Time-Out Period} = \frac{\text{Clock Divider Ratio} \times \text{Reload Value}}{\text{System Clock Frequency}}$$

To calculate the time-out period with the above equation when using an initial value of 0000h, enter a reload value of 65536 (FFFFh + 1).

Minimum time-out duration is 4 times longer than the input clock period and is generated by setting the clock divider ratio to 1:4 and the reload value to 0001h. Maximum time-out duration is 2^{24} (16,777,216) times longer than the input clock period and is generated by setting the clock divider ratio to 1:256 and the reload value to 0000h.

SINGLE PASS Mode

In SINGLE PASS mode, when the end-of-count value, 0000h, is reached, counting halts, the timer is disabled, and the PRT_EN bit resets to 0. To restart the timer, the CPU must reenable the timer by setting the PRT_EN bit to 1. An example of a PRT operating in SINGLE PASS mode is illustrated in Figure 19. Timer register information is indicated in Table 29.

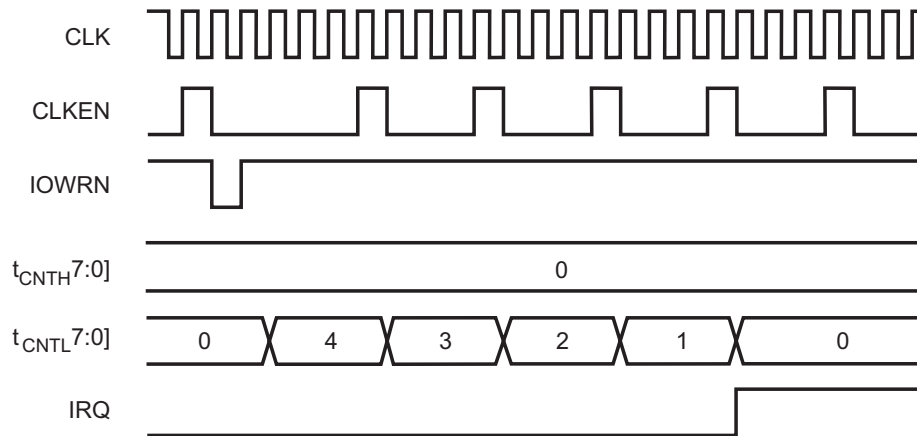

Figure 19. PRT Single Pass Mode Operation Example

Table 29. PRT SINGLE PASS Mode Operation Example

| Parameter | Control Register(s) | Value |
|----------------------------|------------------------|-------|
| PRT Enabled | TMRx_CTL[0] | 1 |
| Reload and Restart Enabled | TMRx_CTL[1] | 1 |
| PRT Clock Divider = 4 | TMRx_CTL[3:2] | 00b |
| SINGLE PASS Mode | TMRx_CTL[4] | 0 |
| PRT Interrupt Enabled | TMRx_CTL[6] | 1 |
| PRT Reload Value | {TMRx_RR_H, TMRx_RR_L} | 0004h |

CONTINUOUS Mode

In CONTINUOUS mode, when the end-of-count value, 0000h, is reached, the timer automatically reloads the 16-bit start value from the Timer Reload registers, TMRx_RR_H and TMRx_RR_L. Dncounting continues on the next clock edge. In CONTINUOUS mode, the PRT continues to count until disabled. An example of a PRT operating in CONTINUOUS mode is illustrated in Figure 20. Timer register information is indicated in Table 30.

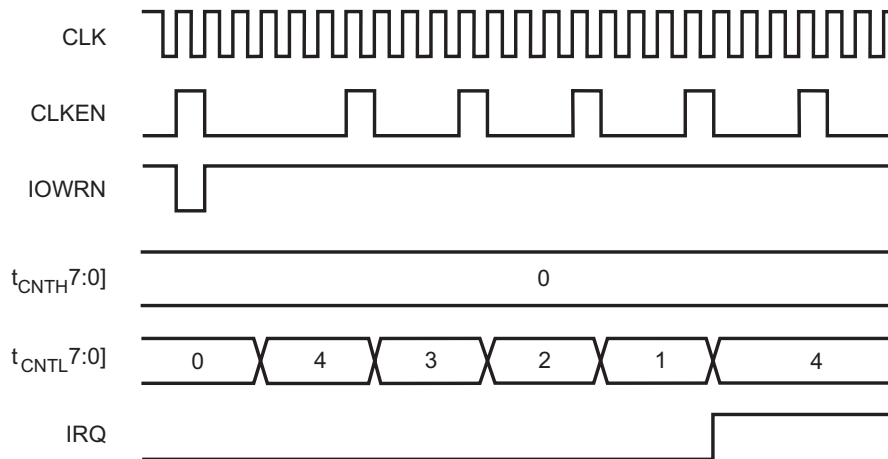

Figure 20. PRT CONTINUOUS Mode Operation Example

Table 30. PRT CONTINUOUS Mode Operation Example

| Parameter | Control Register(s) | Value |
|----------------------------|------------------------|-------|
| PRT Enabled | TMRx_CTL[0] | 1 |
| Reload and Restart Enabled | TMRx_CTL[1] | 1 |
| PRT Clock Divider = 4 | TMRx_CTL[3:2] | 00b |
| CONTINUOUS Mode | TMRx_CTL[4] | 1 |
| PRT Interrupt Enabled | TMRx_CTL[6] | 1 |
| PRT Reload Value | {TMRx_RR_H, TMRx_RR_L} | 0004h |

Reading the Current Count Value

The CPU is capable of reading the current count value while the timer is running. This READ event does not affect timer operation. The High byte of the current count value is latched during a Read of the Low byte.

Timer Interrupts

The timer interrupt flag, PRT_IRQ, is set to 1 whenever the timer reaches its end-of-count value, 0000h, in SINGLE PASS mode, or when the timer reloads the start value in CONTINUOUS mode. The interrupt flag is only set when the timer reaches 0000h (or reloads) from 0001h. The timer interrupt flag is not set to 1 when the timer is loaded with the value 0000h, which selects the maximum time-out period.



The CPU can be programmed to poll the PRT_IRQ bit for the time-out event. Alternatively, an interrupt service request signal can be sent to the CPU by setting IRQ_EN to 1. Then, when the end-of-count value, 0000h, is reached and PRT_IRQ is set to 1, an interrupt service request signal is passed to the CPU. PRT_IRQ is cleared to 0 and the interrupt service request signal is inactivated whenever the CPU reads from the timer control registers, TMRx_CTL.

Timer Input Source Selection

Timers 0–3 feature programmable input source selection. By default, the input is taken from the eZ80L92's system clock. Alternatively, Timers 0–3 can take their input from port input pins PB0 (Timers 0 and 2) or PB1 (Timers 1 and 3). Timers 0–3 can also use the Real-Time Clock clock source (50, 60, or 32768Hz) as their clock sources. When the timer clock source is the Real-Time Clock signal, the timer decrements on the second rising edge of the system clock following the falling edge of the RTC_XOUT pin. The input source for these timers is set using the Timer Input Source Select register.

Event Counter

When Timers 0–3 are configured to take their inputs from port input pins PB0 and PB1, they function as event counters. For event counting, the clock prescaler is bypassed. The PRT counters decrement on every rising edge of the port pin. The port pins must be configured as inputs. Due to the input sampling on the pins, the event input signal frequency is limited to one-half the system clock frequency. Input sampling on the port pins results in the PRT counter being updated on the fifth rising edge of the system clock after the rising edge occurs at the port pin.

Timer Output

Two of the Programmable Reload Timers (Timers 4 and 5) can be directed to GPIO Port B output pins (PB4 and PB5, respectively). To enable the Timer Out feature, the GPIO port pin must be configured for alternate functions. After reset, the Timer Output feature is disabled by default. The GPIO output pin toggles each time the PRT reaches its end-of-count value. In CONTINUOUS mode operation, the disabling of the Timer Output feature results in a Timer Output signal period that is twice the PRT time-out period. Examples of the Timer Output operation are illustrated in Figure 21 and Table 31. In these examples, the GPIO output is assumed to be Low (0) when the Timer Output function is enabled.

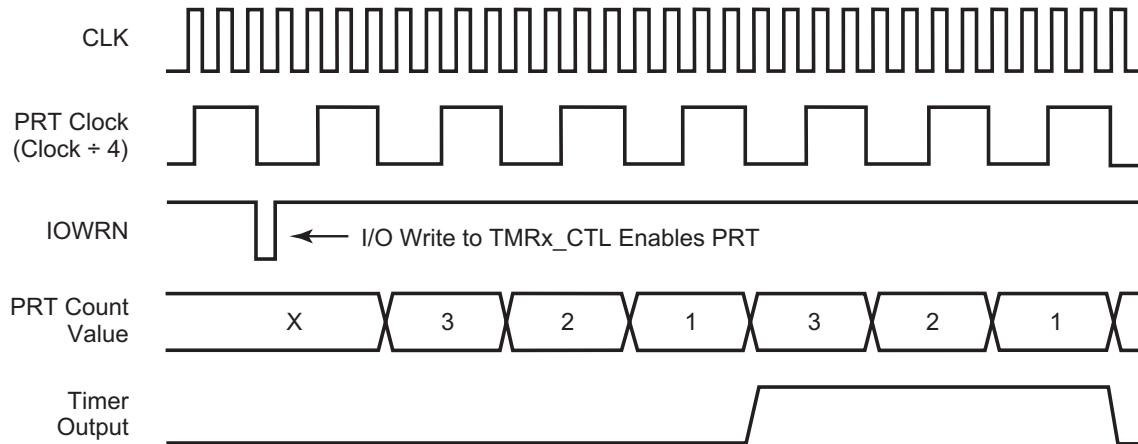

Figure 21. PRT Timer Output Operation Example

Table 31. PRT Timer Out Operation Example

| Parameter | Control Register(s) | Value |
|----------------------------|------------------------|-------|
| PRT Enabled | TMRx_CTL[0] | 1 |
| Reload and Restart Enabled | TMRx_CTL[1] | 1 |
| PRT Clock Divider = 4 | TMRx_CTL[3:2] | 00b |
| CONTINUOUS Mode | TMRx_CTL[4] | 1 |
| PRT Reload Value | {TMRx_RR_H, TMRx_RR_L} | 0003h |

Programmable Reload Timer Registers

Each programmable reload timer is controlled using five 8-bit registers. These registers are the Timer Control register, Timer Reload Low Byte register, Timer Reload High Byte register, Timer Data Low Byte register, and Timer Data High Byte register.

The Timer Control register can be read or written to. The timer reload registers are Write-Only and are located at the same I/O address as the timer data registers, which are Read-Only.

Timer Control Registers

The Timer Control register, detailed in Table 32, is used to control operation of the timer, including enabling the timer, selecting the clock divider, enabling the interrupt, selecting between CONTINUOUS and SINGLE PASS modes, and enabling the auto-reload feature.



Table 32. Timer Control Registers
 (TMR0_CTL = 0080h, TMR1_CTL = 0083h, TMR2_CTL = 0086h,
 TMR3_CTL = 0089h, TMR4_CTL = 008Ch, or TMR5_CTL = 008Fh)

| Bit | 7 | 6 | 5 | 4 | 3 | 2 | 1 | 0 |
|-------------------|---|-----|-----|-----|-----|-----|-----|-----|
| Reset | 0 | 0 | 0 | 0 | 0 | 0 | 0 | 0 |
| CPU Access | R | R/W | R/W | R/W | R/W | R/W | R/W | R/W |

Note: R = Read only; R/W = Read/Write.

| Bit Position | Value | Description |
|------------------|-------|---|
| 7 PRT_IRQ | 0 | The timer does not reach its end-of-count value. This bit is reset to 0 every time the TMRx_CTL register is read. |
| | 1 | The timer reaches its end-of-count value. If IRQ_EN is set to 1, an interrupt signal is sent to the CPU. This bit remains 1 until the TMRx_CTL register is read. |
| 6 IRQ_EN | 0 | Timer interrupt requests are disabled. |
| | 1 | Timer interrupt requests are enabled. |
| 5 | 0 | Reserved. |
| 4 PRT_MODE | 0 | The timer operates in SINGLE PASS mode. PRT_EN (bit 0) is reset to 0, and counting stops when the end-of-count value is reached. |
| | 1 | The timer operates in CONTINUOUS mode. The timer reload value is written to the counter when the end-of-count value is reached. |
| [3:2] CLK_DIV | 00 | Clock ÷ 4 is the timer input source. |
| | 01 | Clock ÷ 16 is the timer input source. |
| | 10 | Clock ÷ 64 is the timer input source. |
| | 11 | Clock ÷ 256 is the timer input source. |
| 1 RST_EN | 0 | The automatic reload and restart function is disabled. |
| | 1 | The automatic reload and restart function is enabled. When a 1 is written to RST_EN, the values in the reload registers are loaded into the downcounter and the timer restarts. |
| 0 PRT_EN | 0 | The programmable reload timer is disabled. |
| | 1 | The programmable reload timer is enabled. |



Timer Data Registers—Low Byte

This Read-Only register returns the Low byte of the current count value of the selected timer. The Timer Data Register—Low Byte, detailed in Table 33, can be read while the timer is in operation. Reading the current count value does not affect timer operation. To read the 16-bit data of the current count value, {TMRx_DR_H[7:0], TMRx_DR_L[7:0]}, first read the Timer Data Register—Low Byte and then read the Timer Data Register—High Byte. The Timer Data Register—High Byte value is latched when a Read of the Timer Data Register—Low Byte occurs.

- **Note:** The Timer Data registers and Timer Reload registers share the same address space.

Table 33. Timer Data Registers—Low Byte
(TMR0_DR_L = 0081h, TMR1_DR_L = 0084h, TMR2_DR_L = 0087h,
TMR3_DR_L = 008Ah, TMR4_DR_L = 008Dh, or TMR5_DR_L = 0090h)

| Bit | 7 | 6 | 5 | 4 | 3 | 2 | 1 | 0 |
|------------|---|---|---|---|---|---|---|---|
| Reset | 0 | 0 | 0 | 0 | 0 | 0 | 0 | 0 |
| CPU Access | R | R | R | R | R | R | R | R |

Note: R = Read only.

| Bit Position | Value | Description |
|--------------------|---------|---|
| [7:0] TMRx_DR_L | 00h–FFh | These bits represent the Low byte of the 2-byte timer data value, {TMRx_DR_H[7:0], TMRx_DR_L[7:0]}. Bit 7 is bit 7 of the 16-bit timer data value. Bit 0 is bit 0 (lsb) of the 16-bit timer data value. |

Timer Data Registers—High Byte

This Read-Only register returns the High byte of the current count value of the selected timer. The Timer Data Register—High Byte, detailed in Table 34, can be read while the timer is in operation. Reading the current count value does not affect timer operation. To read the 16-bit data of the current count value, {TMRx_DR_H[7:0], TMRx_DR_L[7:0]}, first read the Timer Data Register—Low Byte and then read the Timer Data Register—High Byte. The Timer Data Register—High Byte value is latched when a Read of the Timer Data Register—Low Byte occurs.

- **Note:** The timer data registers and timer reload registers share the same address space.



Table 34. Timer Data Registers—High Byte
(TMR0_DR_H = 0082h, TMR1_DR_H = 0085h, TMR2_DR_H = 0088h,
TMR3_DR_H = 008Bh, TMR4_DR_H = 008Eh, or TMR5_DR_H = 0091h)

| Bit | 7 | 6 | 5 | 4 | 3 | 2 | 1 | 0 |
|------------|---|---|---|---|---|---|---|---|
| Reset | 0 | 0 | 0 | 0 | 0 | 0 | 0 | 0 |
| CPU Access | R | R | R | R | R | R | R | R |

Note: R = Read only.

| Bit Position | Value | Description |
|--------------------|---------|---|
| [7:0] TMRx_DR_H | 00h–FFh | These bits represent the High byte of the 2-byte timer data value, {TMRx_DR_H[7:0], TMRx_DR_L[7:0]}. Bit 7 is bit 15 (msb) of the 16-bit timer data value. Bit 0 is bit 8 of the 16-bit timer data value. |

Timer Reload Registers—Low Byte

The Timer Reload Register—Low Byte, detailed in Table 35, stores the least significant byte (LSB) of the 2-byte timer reload value. In CONTINUOUS mode, the timer reload value is reloaded into the timer upon end-of-count. When RST_EN (TMRx_CTL[1]) is set to 1 to enable the automatic reload and restart function, the timer reload value is written to the timer on the next rising edge of the clock.

► **Note:** The Timer Data registers and Timer Reload registers share the same address space.

Table 35. Timer Reload Registers—Low Byte
(TMR0_RR_L = 0081h, TMR1_RR_L = 0084h, TMR2_RR_L = 0087h,
TMR3_RR_L = 008Ah, TMR4_RR_L = 008Dh, or TMR5_RR_L = 0090h)

| Bit | 7 | 6 | 5 | 4 | 3 | 2 | 1 | 0 |
|------------|---|---|---|---|---|---|---|---|
| Reset | 0 | 0 | 0 | 0 | 0 | 0 | 0 | 0 |
| CPU Access | W | W | W | W | W | W | W | W |

Note: W = Write only.

| Bit Position | Value | Description |
|--------------------|---------|---|
| [7:0] TMRx_RR_L | 00h–FFh | These bits represent the Low byte of the 2-byte timer reload value, {TMRx_RR_H[7:0], TMRx_RR_L[7:0]}. Bit 7 is bit 7 of the 16-bit timer reload value. Bit 0 is bit 0 (lsb) of the 16-bit timer reload value. |



Timer Reload Registers—High Byte

The Timer Reload Register—High Byte, detailed in Table 36, stores the most significant byte (MSB) of the 2-byte timer reload value. In CONTINUOUS mode, the timer reload value is reloaded into the timer upon end-of-count. When RST_EN (TMRx_CTL[1]) is set to 1 to enable the automatic reload and restart function, the timer reload value is written to the timer on the next rising edge of the clock.

► **Note:** The Timer Data registers and Timer Reload registers share the same address space.

Table 36. Timer Reload Registers—High Byte
(TMR0_RR_H = 0082h, TMR1_RR_H = 0085h, TMR2_RR_H = 0088h,
TMR3_RR_H = 008Bh, TMR4_RR_H = 008Eh, or TMR5_RR_H = 0091h)

| Bit | 7 | 6 | 5 | 4 | 3 | 2 | 1 | 0 |
|------------|---|---|---|---|---|---|---|---|
| Reset | 0 | 0 | 0 | 0 | 0 | 0 | 0 | 0 |
| CPU Access | W | W | W | W | W | W | W | W |

Note: W = Write only.

| Bit Position | Value | Description |
|--------------------|---------|---|
| [7:0] TMRx_RR_H | 00h–FFh | These bits represent the High byte of the 2-byte timer reload value, {TMRx_RR_H[7:0], TMRx_RR_L[7:0]}. Bit 7 is bit 15 (msb) of the 16-bit timer reload value. Bit 0 is bit 8 of the 16-bit timer reload value. |

Timer Input Source Select Register

The Timer Input Source Select register, detailed in Table 37, sets the input source for Programmable Reload Timer 0–3 (TMR0, TMR1, TMR2, TMR3). Event frequency must be less than one-half of the system clock frequency. When configured for event inputs through the port pins, the Timers decrement on the fifth system clock rising edge following the rising edge of the port pin.

Table 37. Timer Input Source Select Register (TMR_ISS = 0092h)

| Bit | 7 | 6 | 5 | 4 | 3 | 2 | 1 | 0 |
|------------|-----|-----|-----|-----|-----|-----|-----|-----|
| Reset | 0 | 0 | 0 | 0 | 0 | 0 | 0 | 0 |
| CPU Access | R/W | R/W | R/W | R/W | R/W | R/W | R/W | R/W |

Note: R/W = Read/Write.



| Bit Position | Value | Description |
|------------------|-------|---|
| [7:6] TMR3_IN | 00 | The timer counts at the system clock divided by the prescaler. |
| | 01 | The timer event input is the Real-Time Clock source (32KHz or 50/60Hz—refer to the Real-Time Clock section on page 86 for details). |
| | 10 | The timer event input is the GPIO Port B pin 1. |
| | 11 | The timer event input is the GPIO Port B pin 1. |
| [5:4] TMR2_IN | 00 | The timer counts at the system clock divided by the prescaler. |
| | 01 | The timer event input is the Real-Time Clock source (32KHz or 50/60Hz—refer to the Real-Time Clock section on page 86 for details). |
| | 10 | The timer event input is the GPIO Port B pin 0. |
| | 11 | The timer event input is the GPIO Port B pin 0. |
| [3:2] TMR1_IN | 00 | The timer counts at the system clock divided by the prescaler. |
| | 01 | The timer event input is the Real-Time Clock source (32KHz or 50/60Hz—refer to the Real-Time Clock section on page 86 for details). |
| | 10 | The timer event input is the GPIO Port B pin 1. |
| | 11 | The timer event input is the GPIO Port B pin 1. |
| [1:0] TMR0_IN | 00 | Timer counts at system clock divided by prescaler. |
| | 01 | Timer event input is Real-Time Clock source (32KHz or 50/60Hz—refer to the Real-Time Clock section on page 86 for details). |
| | 10 | The timer event input is the GPIO Port B pin 0. |
| | 11 | The timer event input is the GPIO Port B pin 0. |

Real-Time Clock

Real-Time Clock Overview

The Real-Time Clock (RTC) keeps time by maintaining a count of seconds, minutes, hours, day-of-the-week, day-of-the-month, year, and century. The current time is kept in 24-hour format. The format for all count and alarm registers is selectable between binary and binary-coded-decimal (BCD). The calendar operation maintains the correct day of the month and automatically compensates for leap year. A simplified block diagram of the RTC and the associated on-chip, low-power, 32KHz oscillator is illustrated in Figure 22. Connections to an external battery supply and 32KHz crystal network are also demonstrated in Figure 22.

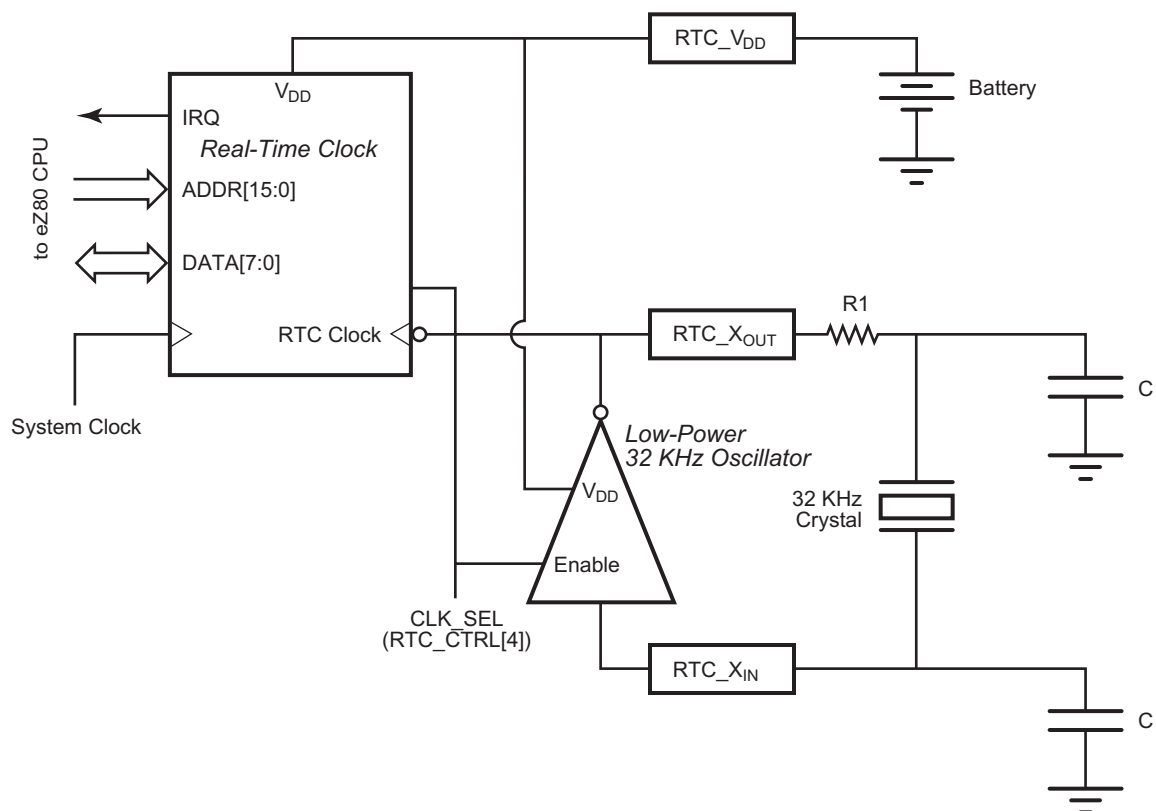

Figure 22. Real-Time Clock and 32KHz Oscillator Block Diagram



Real-Time Clock Alarm

The clock can be programmed to generate an alarm condition when the current count matches the alarm set-point registers. Alarm registers are available for seconds, minutes, hours, and day-of-the-week. Each alarm can be independently enabled. To generate an alarm condition, the current time must match **all** enabled alarm values. For example, if the day-of-the-week and hour alarms are both enabled, the alarm only occurs at the specified hour on the specified day. The alarm triggers an interrupt if the interrupt enable bit, INT_EN, is set. The alarm flag, ALARM, and corresponding interrupt to the CPU are cleared by reading the RTC_CTRL register.

Alarm value registers and alarm control registers can be written at any time. Alarm conditions are generated when the count value matches the alarm value. The comparison of alarm and count values occurs whenever the RTC count increments (one time every second). The RTC can also be forced to perform a comparison at any time by writing a 0 to RTC_UNLOCK (RTC_UNLOCK is not required to be changed to a 1 first).

Real-Time Clock Oscillator and Source Selection

The RTC count is driven by either the on-chip 32768Hz crystal oscillator or a 50/60Hz power-line frequency input connected to the 32KHz RTC_XOUT pin. An internal divider compensates for each of these options. The clock source and power-line frequencies are selected in the RTC_CTRL register. Writing to the RTC_CTRL register resets the clock divider.

Real-Time Clock Battery Backup

The power supply pin (RTC_V_{DD}) for the Real-Time Clock and associated low-power 32KHz oscillator is isolated from the other power supply pins on the eZ80L92. To ensure that the RTC continues to keep time in the event of loss of line power to the application, a battery can be used to supply power to the RTC and the oscillator via the RTC_V_{DD} pin. All V_{SS} (ground) pins should be connected together on the printed circuit assembly.

Real-Time Clock Recommended Operation

Following a RESET from a powered-down condition, the counter values of the RTC are undefined and all alarms are disabled. After a RESET from a powered-down condition, the following procedure is recommended:

- Write to RTC_CTRL to set RTC_UNLOCK and CLK_SEL
- Write values to the RTC count registers to set the current time



- Write values to the RTC alarm registers to set the appropriate alarm conditions
- Write to RTC_CTRL to clear RTC_UNLOCK; clearing the RTC_UNLOCK bit resets and enables the clock divider

Real-Time Clock Registers

The real-time clock registers are accessed via the address and data bus using I/O instructions. RTC_UNLOCK controls access to the RTC count registers. When unlocked (RTC_UNLOCK = 1), the RTC count is disabled and the count registers are Read/Write. When locked (RTC_UNLOCK = 0), the RTC count is enabled and the count registers are Read-Only. The default, at RESET, is for the RTC to be locked.

Real-Time Clock Seconds Register

This register contains the current seconds count. The value in the RTC_SEC register is unchanged by a RESET. The current setting of BCD_EN determines whether the values in this register are binary (BCD_EN = 0) or binary-coded decimal (BCD_EN = 1). Access to this register is Read-Only if the RTC is locked and Read/Write if the RTC is unlocked. See Table 38.

Table 38. Real-Time Clock Seconds Register (RTC_SEC = 00E0h)

| Bit | 7 | 6 | 5 | 4 | 3 | 2 | 1 | 0 |
|------------|------|------|------|------|------|------|------|------|
| Reset | X | X | X | X | X | X | X | X |
| CPU Access | R/W* | R/W* | R/W* | R/W* | R/W* | R/W* | R/W* | R/W* |

Note: X = Unchanged by RESET; R/W* = Read-only if RTC locked, Read/Write if RTC unlocked.

Binary-Coded-Decimal Operation (BCD_EN = 1)

| Bit Position | Value | Description |
|------------------|-------|--|
| [7:4] TEN_SEC | 0–5 | The tens digit of the current seconds count. |
| [3:0] SEC | 0–9 | The ones digit of the current seconds count. |

Binary Operation (BCD_EN = 0)

| Bit Position | Value | Description |
|--------------|-------------|----------------------------|
| [7:0] SEC | 00h– 3Bh | The current seconds count. |



Real-Time Clock Minutes Register

This register contains the current minutes count. See Table 39.

Table 39. Real-Time Clock Minutes Register (RTC_MIN = 00E1h)

| Bit | 7 | 6 | 5 | 4 | 3 | 2 | 1 | 0 |
|------------|------|------|------|------|------|------|------|------|
| Reset | X | X | X | X | X | X | X | X |
| CPU Access | R/W* | R/W* | R/W* | R/W* | R/W* | R/W* | R/W* | R/W* |

Note: X = Unchanged by RESET; R/W* = Read-only if RTC locked, Read/Write if RTC unlocked.

Binary-Coded-Decimal Operation (BCD_EN = 1)

| Bit Position | Value | Description |
|------------------|-------|--|
| [7:4] TEN_MIN | 0–5 | The tens digit of the current minutes count. |
| [3:0] MIN | 0–9 | The ones digit of the current minutes count. |

Binary Operation (BCD_EN = 0)

| Bit Position | Value | Description |
|--------------|-------------|----------------------------|
| [7:0] MIN | 00h– 3Bh | The current minutes count. |



Real-Time Clock Hours Register

This register contains the current hours count. See Table 40.

Table 40. Real-Time Clock Hours Register (RTC_HRS = 00E2h)

| Bit | 7 | 6 | 5 | 4 | 3 | 2 | 1 | 0 |
|------------|------|------|------|------|------|------|------|------|
| Reset | X | X | X | X | X | X | X | X |
| CPU Access | R/W* | R/W* | R/W* | R/W* | R/W* | R/W* | R/W* | R/W* |

Note: X = Unchanged by RESET; R/W* = Read-only if RTC locked, Read/Write if RTC unlocked.

Binary-Coded-Decimal Operation (BCD_EN = 1)

| Bit Position | Value | Description |
|------------------|-------|--|
| [7:4] TEN_HRS | 0–2 | The tens digit of the current hours count. |
| [3:0] HRS | 0–9 | The ones digit of the current hours count. |

Binary Operation (BCD_EN = 0)

| Bit Position | Value | Description |
|--------------|-------------|--------------------------|
| [7:0] HRS | 00h– 17h | The current hours count. |



Real-Time Clock Day-of-the-Week Register

This register contains the current day-of-the-week count. The RTC_DOW register begins counting at 01h. See Table 41.

Table 41. Real-Time Clock Day-of-the-Week Register (RTC_DOW = 00E3h)

| Bit | 7 | 6 | 5 | 4 | 3 | 2 | 1 | 0 |
|------------|---|---|---|---|------|------|------|------|
| Reset | 0 | 0 | 0 | 0 | X | X | X | X |
| CPU Access | R | R | R | R | R/W* | R/W* | R/W* | R/W* |

Note: X = Unchanged by RESET; R = Read Only; R/W* = Read-only if RTC locked, Read/Write if RTC unlocked.

Binary-Coded-Decimal Operation (BCD_EN = 1)

| Bit Position | Value | Description |
|--------------|-------|------------------------------------|
| [7:4] | 0000 | Reserved. |
| [3:0] DOW | 1-7 | The current day-of-the-week count. |

Binary Operation (BCD_EN = 0)

| Bit Position | Value | Description |
|--------------|-------------|------------------------------------|
| [7:4] | 0000 | Reserved. |
| [3:0] DOW | 01h– 07h | The current day-of-the-week count. |



Real-Time Clock Day-of-the-Month Register

This register contains the current day-of-the-month count. The RTC_DOM register begins counting at 01h. See Table 42.

Table 42. Real-Time Clock Day-of-the-Month Register (RTC_DOM = 00E4h)

| Bit | 7 | 6 | 5 | 4 | 3 | 2 | 1 | 0 |
|------------|------|------|------|------|------|------|------|------|
| Reset | X | X | X | X | X | X | X | X |
| CPU Access | R/W* | R/W* | R/W* | R/W* | R/W* | R/W* | R/W* | R/W* |

Note: X = Unchanged by RESET; R/W* = Read-only if RTC locked, Read/Write if RTC unlocked.

Binary-Coded-Decimal Operation (BCD_EN = 1)

| Bit Position | Value | Description |
|-------------------|-------|---|
| [7:4] TENS_DOM | 0–3 | The tens digit of the current day-of-the-month count. |
| [3:0] DOM | 0–9 | The ones digit of the current day-of-the-month count. |

Binary Operation (BCD_EN = 0)

| Bit Position | Value | Description |
|--------------|-------------|-------------------------------------|
| [7:0] DOM | 01h– 1Fh | The current day-of-the-month count. |



Real-Time Clock Month Register

This register contains the current month count. See Table 43.

Table 43. Real-Time Clock Month Register (RTC_MON = 00E5h)

| Bit | 7 | 6 | 5 | 4 | 3 | 2 | 1 | 0 |
|------------|------|------|------|------|------|------|------|------|
| Reset | X | X | X | X | X | X | X | X |
| CPU Access | R/W* | R/W* | R/W* | R/W* | R/W* | R/W* | R/W* | R/W* |

Note: X = Unchanged by RESET; R/W* = Read-only if RTC locked, Read/Write if RTC unlocked.

Binary-Coded-Decimal Operation (BCD_EN = 1)

| Bit Position | Value | Description |
|-------------------|-------|--|
| [7:4] TENS_MON | 0–1 | The tens digit of the current month count. |
| [3:0] MON | 0–9 | The ones digit of the current month count. |

Binary Operation (BCD_EN = 0)

| Bit Position | Value | Description |
|--------------|-------------|--------------------------|
| [7:0] MON | 01h– 0Ch | The current month count. |



Real-Time Clock Year Register

This register contains the current year count. See Table 44.

Table 44. Real-Time Clock Year Register (RTC_YR = 00E6h)

| Bit | 7 | 6 | 5 | 4 | 3 | 2 | 1 | 0 |
|------------|------|------|------|------|------|------|------|------|
| Reset | X | X | X | X | X | X | X | X |
| CPU Access | R/W* | R/W* | R/W* | R/W* | R/W* | R/W* | R/W* | R/W* |

Note: X = Unchanged by RESET; R/W* = Read-only if RTC locked, Read/Write if RTC unlocked.

Binary-Coded-Decimal Operation (BCD_EN = 1)

| Bit Position | Value | Description |
|------------------|-------|---|
| [7:4] TENS_YR | 0–9 | The tens digit of the current year count. |
| [3:0] YR | 0–9 | The ones digit of the current year count. |

Binary Operation (BCD_EN = 0)

| Bit Position | Value | Description |
|--------------|-------------|-------------------------|
| [7:0] YR | 00h– 63h | The current year count. |



Real-Time Clock Century Register

This register contains the current century count. See Table 45.

Table 45. Real-Time Clock Century Register (RTC_CEN = 00E7h)

| Bit | 7 | 6 | 5 | 4 | 3 | 2 | 1 | 0 |
|------------|------|------|------|------|------|------|------|------|
| Reset | X | X | X | X | X | X | X | X |
| CPU Access | R/W* | R/W* | R/W* | R/W* | R/W* | R/W* | R/W* | R/W* |

Note: X = Unchanged by RESET; R/W* = Read-only if RTC locked, Read/Write if RTC unlocked.

Binary-Coded-Decimal Operation (BCD_EN = 1)

| Bit Position | Value | Description |
|-------------------|-------|--|
| [7:4] TENS_CEN | 0–9 | The tens digit of the current century count. |
| [3:0] CEN | 0–9 | The ones digit of the current century count. |

Binary Operation (BCD_EN = 0)

| Bit Position | Value | Description |
|--------------|-------------|----------------------------|
| [7:0] CEN | 00h– 63h | The current century count. |



Real-Time Clock Alarm Seconds Register

This register contains the alarm seconds value. See Table 46.

Table 46. Real-Time Clock Alarm Seconds Register (RTC_ASEC = 00E8h)

| Bit | 7 | 6 | 5 | 4 | 3 | 2 | 1 | 0 |
|------------|-----|-----|-----|-----|-----|-----|-----|-----|
| Reset | X | X | X | X | X | X | X | X |
| CPU Access | R/W | R/W | R/W | R/W | R/W | R/W | R/W | R/W |

Note: X = Unchanged by RESET; R/W = Read/Write.

Binary-Coded-Decimal Operation (BCD_EN = 1)

| Bit Position | Value | Description |
|-------------------|-------|--|
| [7:4] ATEN_SEC | 0–5 | The tens digit of the alarm seconds value. |
| [3:0] ASEC | 0–9 | The ones digit of the alarm seconds value. |

Binary Operation (BCD_EN = 0)

| Bit Position | Value | Description |
|---------------|-------------|--------------------------|
| [7:0] ASEC | 00h– 3Bh | The alarm seconds value. |



Real-Time Clock Alarm Minutes Register

This register contains the alarm minutes value. See Table 47.

Table 47. Real-Time Clock Alarm Minutes Register (RTC_AMIN = 00E9h)

| Bit | 7 | 6 | 5 | 4 | 3 | 2 | 1 | 0 |
|------------|-----|-----|-----|-----|-----|-----|-----|-----|
| Reset | X | X | X | X | X | X | X | X |
| CPU Access | R/W | R/W | R/W | R/W | R/W | R/W | R/W | R/W |

Note: X = Unchanged by RESET; R/W = Read/Write.

Binary-Coded-Decimal Operation (BCD_EN = 1)

| Bit Position | Value | Description |
|-------------------|-------|--|
| [7:4] ATEN_MIN | 0–5 | The tens digit of the alarm minutes value. |
| [3:0] AMIN | 0–9 | The ones digit of the alarm minutes value. |

Binary Operation (BCD_EN = 0)

| Bit Position | Value | Description |
|---------------|-------------|--------------------------|
| [7:0] AMIN | 00h– 3Bh | The alarm minutes value. |



Real-Time Clock Alarm Hours Register

This register contains the alarm hours value. See Table 48.

Table 48. Real-Time Clock Alarm Hours Register (RTC_AHRS = 00EAh)

| Bit | 7 | 6 | 5 | 4 | 3 | 2 | 1 | 0 |
|------------|-----|-----|-----|-----|-----|-----|-----|-----|
| Reset | X | X | X | X | X | X | X | X |
| CPU Access | R/W | R/W | R/W | R/W | R/W | R/W | R/W | R/W |

Note: X = Unchanged by RESET; R/W = Read/Write.

Binary-Coded-Decimal Operation (BCD_EN = 1)

| Bit Position | Value | Description |
|-------------------|-------|--|
| [7:4] ATEN_HRS | 0–2 | The tens digit of the alarm hours value. |
| [3:0] AHRS | 0–9 | The ones digit of the alarm hours value. |

Binary Operation (BCD_EN = 0)

| Bit Position | Value | Description |
|---------------|-------------|------------------------|
| [7:0] AHRS | 00h– 17h | The alarm hours value. |



Real-Time Clock Alarm Day-of-the-Week Register

This register contains the alarm day-of-the-week value. See Table 49.

Table 49. Real-Time Clock Alarm Day-of-the-Week Register (RTC_ADOW = 00EBh)

| Bit | 7 | 6 | 5 | 4 | 3 | 2 | 1 | 0 |
|------------|---|---|---|---|------|------|------|------|
| Reset | 0 | 0 | 0 | 0 | X | X | X | X |
| CPU Access | R | R | R | R | R/W* | R/W* | R/W* | R/W* |

Note: X = Unchanged by RESET; R = Read Only; R/W* = Read-only if RTC locked, Read/Write if RTC unlocked.

Binary-Coded-Decimal Operation (BCD_EN = 1)

| Bit Position | Value | Description |
|---------------|-------|----------------------------------|
| [7:4] | 0000 | Reserved. |
| [3:0] ADOW | 1-7 | The alarm day-of-the-week.value. |

Binary Operation (BCD_EN = 0)

| Bit Position | Value | Description |
|---------------|-------------|----------------------------------|
| [7:4] | 0000 | Reserved. |
| [3:0] ADOW | 01h– 07h | The alarm day-of-the-week value. |



Real-Time Clock Alarm Control Register

This register contains alarm enable bits for the real-time clock. The RTC_ACTRL register is cleared by a RESET. See Table 50.

Table 50. Real-Time Clock Alarm Control Register (RTC_ACTRL = 00ECh)

| Bit | 7 | 6 | 5 | 4 | 3 | 2 | 1 | 0 |
|------------|---|---|---|---|-----|-----|-----|-----|
| Reset | 0 | 0 | 0 | 0 | 0 | 0 | 0 | 0 |
| CPU Access | R | R | R | R | R/W | R/W | R/W | R/W |

Note: X = Unchanged by RESET; R/W = Read/Write; R = Read Only.

| Bit Position | Value | Description |
|--------------|-------|--|
| [7:4] | 0000 | Reserved. |
| 3 | 0 | The day-of-the-week alarm is disabled. |
| ADOW_EN | 1 | The day-of-the-week alarm is enabled. |
| 2 | 0 | The hours alarm is disabled. |
| AHRS_EN | 1 | The hours alarm is enabled. |
| 1 | 0 | The minutes alarm is disabled. |
| AMIN_EN | 1 | The minutes alarm is enabled. |
| 0 | 0 | The seconds alarm is disabled. |
| ASEC_EN | 1 | The seconds alarm is enabled. |

Real-Time Clock Control Register

This register contains control and status bits for the real-time clock. Some bits in the RTC_CTRL register are cleared by a RESET. The ALARM flag and associated interrupt (if INT_EN is enabled) are cleared by reading this register. The ALARM flag is updated by clearing (locking) RTC_UNLOCK or by an increment of the RTC count. Writing to the RTC_CTRL register also resets the RTC count prescaler allowing the RTC to be synchronized to another time source.

SLP_WAKE indicates if an RTC alarm condition initiated the CPU recovery from SLEEP mode. This bit can be checked after RESET to determine if a sleep-mode recovery is caused by the RTC. SLP_WAKE is cleared by a Read of the RTC_CTRL register.

Setting BCD_EN causes the RTC to use BCD counting in all registers including the alarm set points.

CLK_SEL and FREQ_SEL select the RTC clock source. If the 32KHz crystal option is selected the oscillator is enabled and the internal prescaler is set to



divide by 32768. If the power-line frequency option is selected, the prescale value is set by `FREQ_SEL`, and the 32Khz oscillator is disabled. See Table 51.

Table 51. Real-Time Clock Control Register (RTC_CTRL = 00EDh)

| Bit | 7 | 6 | 5 | 4 | 3 | 2 | 1 | 0 |
|-------------------|---|-----|-----|-----|-----|---|-----|-----|
| Reset | X | 0 | X | X | X | X | 0/1 | 0 |
| CPU Access | R | R/W | R/W | R/W | R/W | R | R | R/W |

Note: X = Unchanged by RESET; R = Read-only; R/W = Read/Write.

| Bit Position | Value | Description |
|-----------------|-------|---|
| 7 ALARM | 0 | Alarm interrupt is inactive. |
| | 1 | Alarm interrupt is active. |
| 6 INT_EN | 0 | Interrupt on alarm condition is disabled. |
| | 1 | Interrupt on alarm condition is enabled. |
| 5 BCD_EN | 0 | RTC count and alarm value registers are binary. |
| | 1 | RTC count and alarm value registers are binary-coded decimal (BCD). |
| 4 CLK_SEL | 0 | RTC clock source is crystal oscillator output (32768Hz). On-chip 32768Hz oscillator is enabled. |
| | 1 | RTC clock source is power-line frequency input. On-chip 32768Hz oscillator is disabled. |
| 3 FREQ_SEL | 0 | Power-line frequency is 60Hz. |
| | 1 | Power-line frequency is 50Hz. |
| 2 | 0 | Reserved. |
| 1 SLP_WAKE | 0 | RTC does not generate a Sleep-Mode Recovery reset. |
| | 1 | RTC Alarm generates a Sleep-Mode Recovery reset. |
| 0 RTC_UNLOCK | 0 | RTC count registers are locked to prevent write access. RTC counter is enabled. |
| | 1 | RTC count registers are unlocked to allow write access. RTC counter is disabled. |

Universal Asynchronous Receiver/Transmitter

The UART module implements all of the logic required to support various asynchronous communications protocols. The module also implements two separate 16-byte-deep FIFOs for both transmission and reception. A block diagram of the UART is illustrated in Figure 23.

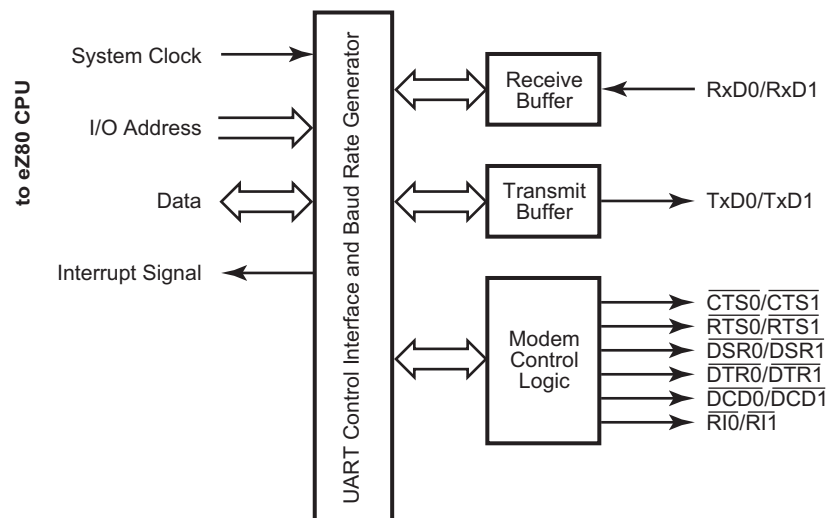

Figure 23. UART Block Diagram

The UART module provides the following asynchronous communication protocol-related features and functions:

- 5-, 6-, 7-, or 8-bit data transmission
- Even/odd or no parity bit generation and detection
- Start and stop bit generation and detection (supports up to two stop bits)
- Line break detection and generation
- Receiver overrun and framing errors detection
- Logic and associated I/O to provide modem handshake capability

UART Functional Description

The UART function implements:



- The transmitter and associated control logic
- The receiver and associated control logic
- The modem interface and associated logic

UART Transmitter

The transmitter block controls the data transmitted on the TxD output. It implements the FIFO, accessed through the UARTx_THR register, the transmit shift register, the parity generator, and control logic for the transmitter to control parameters for the asynchronous communication protocol.

The UARTx_THR is a Write-Only register. The processor writes the data byte to be transmitted into this register. In the FIFO mode, up to 16 data bytes can be written via the UARTx_THR register. The data byte from the FIFO is transferred to the transmit shift register at the appropriate time and transmitted out on TxD output. After SYNC_RESET, the UARTx_THR register is empty. Therefore, the Transmit Holding Register Empty (THRE) bit (bit 5 of the UARTx_LSR register) is 1 and an interrupt is sent to the processor (if interrupts are enabled). The processor can reset this interrupt by loading data into the UARTx_THR register, which clears the transmitter interrupt.

The transmit shift register places the byte to be transmitted on the TxD signal serially. The least-significant bit of the byte to be transmitted is shifted out first and the most significant bit is shifted out last. The control logic within the block adds the asynchronous communication protocol bits to the data byte being transmitted. The transmitter block obtains the parameters for the protocol from the bits programmed via the UARTx_LCTL register. The TxD output is set to 1 if the transmitter is idle (it does not contain any data to be transmitted).

The transmitter operates with the Baud Rate Generator (BRG) clock. The data bits are placed on the TxD output one time every 16 BRG clock cycles. The transmitter block also implements a parity generator that attaches the parity bit to the byte, if programmed.

UART Receiver

The receiver block controls the data reception from the RxD signal. The receiver block implements a receiver shift register, receiver line error condition monitoring logic and receiver data ready logic. It also implements the parity checker.

The UARTx_RBR is a Read-Only register of the module. The processor reads received data from this register. The condition of the UARTx_RBR register is monitored by the DR bit (bit 0 of the UARTx_LSR register). The DR bit is 1 when a data byte is received and transferred to the UARTx_RBR register from the receiver shift register. The DR bit is reset only when the processor reads all of the



received data bytes. If the number of bits received is less than eight, the unused most significant bits of the data byte read are 0.

The receiver uses the clock from the BRG for receiving the data. This clock must be 16 times the appropriate baud rate. The receiver synchronizes the shift clock on the falling edge of the RxD input start bit. It then receives a complete byte according to the set parameters. The receiver also implements logic to detect framing errors, parity errors, overrun errors, and break signals.

UART Modem Control

The modem control logic provides two outputs and four inputs for handshaking with the modem. Any change in the modem status inputs, except RI, is detected and an interrupt can be generated. For RI, an interrupt is generated only when the trailing edge of the RI is detected. The module also provides LOOP mode for self-diagnostics.

UART Interrupts

There are five different sources of interrupts from the UART. The five sources of interrupts are:

- Transmitter
- Receiver (three different interrupts)
- Modem status

UART Transmitter Interrupt

The transmitter interrupt is generated if there is no data available for transmission. This interrupt can be disabled using the individual interrupt enable bit or cleared by writing data into the UARTx_THR register.

UART Receiver Interrupts

A receiver interrupt can be generated by three possible sources. The first source, a receiver data ready, indicates that one or more data bytes are received and are ready to be read. This interrupt is generated if the number of bytes in the receiver FIFO is greater than or equal to the trigger level. If the FIFO is not enabled, the interrupt is generated if the receive buffer contains a data byte. This interrupt is cleared by reading the UARTx_RBR.

The second interrupt source is the receiver time-out. A receiver time-out interrupt is generated when there are fewer data bytes in the receiver FIFO than the trigger level and there are no READs and WRITEs to or from the receiver FIFO for four consecutive byte times. When the receiver time-out interrupt is generated, it is cleared only after emptying the entire receive FIFO.



The first two interrupt sources from the receiver (data ready and time-out) share an interrupt enable bit.

The third source of a receiver interrupt is a line status error, indicating an error in byte reception. This error may result from:

- Incorrect received parity
- Incorrect framing; that is, the stop bit is not detected by receiver at the end of the byte
- Receiver over run condition
- A BREAK condition being detected on the receive data input

An interrupt due to one of the above conditions is cleared when the UARTx_LSR register is read. In FIFO mode, a line status interrupt is generated only after the received byte with an error reaches the top of the FIFO and is ready to be read.

A line status interrupt is activated (provided this interrupt is enabled) as long as the READ pointer of the receiver FIFO points to the location of the FIFO that contains a byte with the error. The interrupt is immediately cleared when the UARTx_LSR register is read. The ERR bit of the UARTx_LSR register is active as long as an erroneous byte is present in the receiver FIFO.

UART Modem Status Interrupt

The modem status interrupt is generated if there is any change in state of the modem status inputs to the UART. This interrupt is cleared when the processor reads the UARTx_MSR register.

UART Recommended Usage

The following is the standard sequence of events that occur in the eZ80L92 using the UART. A description of each follows.

1. Module reset.
2. Control transfers to configure UART operation.
3. Data transfers.

Module Reset. Upon reset, all internal registers are set to their default values. All command status registers are programmed with their default values, and the FIFOs are flushed.

Control Transfers. Based on the requirements of the application, the data transfer baud rate is determined and the BRG is configured to generate a 16X clock frequency. Interrupts are disabled and the communication control parameters are



programmed in the UARTx_LCTL register. The FIFO configuration is determined and the receive trigger levels are set in the UARTx_FCTL register. The status registers, UARTx_LSR and UARTx_MSR, are read, and ensure that none of the interrupt sources are active. The interrupts are enabled (except for the transmit interrupt) and the application is ready to use the module for transmission/reception.

Data Transfers—Transmit. To transmit data, the application enables the transmit interrupt. An interrupt is immediately expected in response. The application reads the UARTx_IIR register and determines that the interrupt occurs due to an empty UARTx_THR register. When the application determines this occurrence, the application writes the transmit data bytes to the UARTx_THR register. The number of bytes that the application writes depends on whether or not the FIFO is enabled. If the FIFO is enabled, the application can write 16 bytes at a time. If not, the application can write one byte at a time. As a result of the first write, the interrupt is deactivated. The processor then waits for the next interrupt. When the interrupt is raised by the UART module, the processor repeats the same process until it exhausts all of the data for transmission.

To control and check the modem status, the application sets up the modem by writing to the UARTx_MCTL register and reading the UARTx_MCTL register before starting the process mentioned above.

Data Transfers—Receive. The receiver is always enabled, and it continually checks for the start bit on the RxD input signal. When an interrupt is raised by the UART module, the application reads the UARTx_IIR register and determines the cause for the interrupt. If the cause is a line status interrupt, the application reads the UARTx_LSR register, reads the data byte and then can discard the byte or take other appropriate action. If the interrupt is caused by a receive-data-ready condition, the application alternately reads the UARTx_LSR and UARTx_RBR registers and removes all of the received data bytes. It reads the UARTx_LSR register before reading the UARTx_RBR register to determine that there is no error in the received data.

To control and check modem status, the application sets up the modem by writing to the UARTx_MCTL register and reading the UARTx_MSR register before starting the process mentioned above.

Poll Mode Transfers. When interrupts are disabled, all data transfers are referred to as poll mode transfers. In poll mode transfers, the application must continually poll the UARTx_LSR register to transmit or receive data without enabling the interrupts. The same holds true for the UARTx_MSR register. If the interrupts are not enabled, the data in the UARTx_IIR register cannot be used to determine the cause of interrupt.



Baud Rate Generator

The Baud Rate Generator consists of a 16-bit downcounter, two registers, and associated decoding logic. The initial value of the Baud Rate Generator is defined by the two BRG Divisor Latch registers, {UARTx_BRG_H, UARTx_BRG_L}. At the rising edge of each system clock, the BRG decrements until it reaches the value 0001h. On the next system clock rising edge, the BRG reloads the initial value from {UARTx_BRG_H, UARTx_BRG_L} and outputs a pulse to indicate the end-of-count. Calculate the UART data rate with the following equation:

$$\text{UART Data Rate (bits/s)} = \frac{\text{System Clock Frequency}}{16 \times (\text{UART Baud Rate Generator Divisor})}$$

Upon RESET, the 16-bit BRG divisor value resets to the smallest allowable value of 0002h. Therefore, the minimum BRG clock divisor ratio is 2. A software Write to either the Low- or High-byte registers for the BRG Divisor Latch causes both the Low and High bytes to load into the BRG counter, and causes the count to restart.

The divisor registers can only be accessed if bit 7 of the UART Line Control register (UARTx_LCTL) is set to 1. After reset, this bit is reset to 0.

Recommended Usage of the Baud Rate Generator

The following is the normal sequence of operations that should occur after the eZ80L92 is powered on to configure the Baud Rate Generator:

- Set UARTx_LCTL[7] to 1 to enable access of the BRG divisor registers
- Program the UARTx_BRG_L and UARTx_BRG_H registers
- Clear UARTx_LCTL[7] to 0 to disable access of the BRG divisor registers

BRG Control Registers

UART Baud Rate Generator Registers—Low and High Bytes

The registers hold the Low and High bytes of the 16-bit divisor count loaded by the processor for UART baud rate generation. The 16-bit clock divisor value is returned by {UARTx_BRG_H, UARTx_BRG_L}, where x is either 0 or 1 to identify the two available UART devices. Upon RESET, the 16-bit BRG divisor value resets to 0002h. The initial 16-bit divisor value must be between 0002h and FFFFh as the values 0000h and 0001h are invalid, and proper operation is not guaranteed. As a result, the minimum BRG clock divisor ratio is 2.

A Write to either the Low- or High-byte registers for the BRG Divisor Latch causes both bytes to be loaded into the BRG counter. The count is then restarted.



Bit 7 of the associated UART Line Control register (UARTx_LCTL) must be set to 1 to access this register. See Tables 52 and 53. Refer to the [UART Line Control Registers](#) (UARTx_LCTL) on page 113 for more information.

- **Note:** The UARTx_BRG_L registers share the same address space with the UARTx_RBR and UARTx_THR registers. The UARTx_BRG_H registers share the same address space with the UARTx_IER registers. Bit 7 of the associated UART Line Control register (UARTx_LCTL) must be set to 1 to enable access to the BRG registers.

Table 52. UART Baud Rate Generator Registers—Low Byte
(UART0_BRG_L = 00C0h, UART1_BRG_L = 00D0h)

| Bit | 7 | 6 | 5 | 4 | 3 | 2 | 1 | 0 |
|------------|-----|-----|-----|-----|-----|-----|-----|-----|
| Reset | 0 | 0 | 0 | 0 | 0 | 0 | 1 | 0 |
| CPU Access | R/W | R/W | R/W | R/W | R/W | R/W | R/W | R/W |

Note: R = Read only; R/W = Read/Write.

| Bit Position | Value | Description |
|----------------------|-------------|--|
| [7:0] UARTx_BRG_L | 00h– FFh | These bits represent the Low byte of the 16-bit Baud Rate Generator divider value. The complete BRG divisor value is returned by {UARTx_BRG_H, UARTx_BRG_L}. |

Table 53. UART Baud Rate Generator Registers—High Byte
(UART0_BRG_H = 00C1h, UART1_BRG_H = 00D1h)

| Bit | 7 | 6 | 5 | 4 | 3 | 2 | 1 | 0 |
|------------|-----|-----|-----|-----|-----|-----|-----|-----|
| Reset | 0 | 0 | 0 | 0 | 0 | 0 | 0 | 0 |
| CPU Access | R/W | R/W | R/W | R/W | R/W | R/W | R/W | R/W |

Note: R = Read only; R/W = Read/Write.

| Bit Position | Value | Description |
|----------------------|-------------|---|
| [7:0] UARTx_BRG_H | 00h– FFh | These bits represent the High byte of the 16-bit Baud Rate Generator divider value. The complete BRG divisor value is returned by {UARTx_BRG_H, UARTx_BRG_L}. |



UART Registers

After a RESET, all UART registers are set to their default values. Any WRITES to unused registers or register bits are ignored and READs return a value of 0. For compatibility with future revisions, unused bits within a register should always be written with a value of 0. Read/Write attributes, reset conditions, and bit descriptions of all of the UART registers are provided in this section.

UART Transmit Holding Registers

If less than eight bits are programmed for transmission, the lower bits of the byte written to this register are selected for transmission. The transmit FIFO is mapped at this address. The user can write up to 16 bytes for transmission at one time to this address if the FIFO is enabled by the application. If the FIFO is disabled, this buffer is only one byte deep.

These registers share the same address space as the UARTx_RBR and UARTx_BRG_L registers. See Table 54.

**Table 54. UART Transmit Holding Registers
(UART0_THR = 00C0h, UART1_THR = 00D0h)**

| Bit | 7 | 6 | 5 | 4 | 3 | 2 | 1 | 0 |
|------------|---|---|---|---|---|---|---|---|
| Reset | X | X | X | X | X | X | X | X |
| CPU Access | W | W | W | W | W | W | W | W |

Note: W = Write only.

| Bit Position | Value | Description |
|--------------|-------------|---------------------|
| [7:0] TxD | 00h– FFh | Transmit data byte. |

UART Receive Buffer Registers

The bits in this register reflect the data received. If less than eight bits are programmed for receive, the lower bits of the byte reflect the bits received whereas upper unused bits are 0. The receive FIFO is mapped at this address. If the FIFO is disabled, this buffer is only one byte deep.

These registers share the same address space as the UARTx_THR and UARTx_BRG_L registers. See Table 55.



Table 55. UART Receive Buffer Registers
(UART0_RBR = 00C0h, UART1_RBR = 00D0h)

| Bit | 7 | 6 | 5 | 4 | 3 | 2 | 1 | 0 |
|------------|---|---|---|---|---|---|---|---|
| Reset | X | X | X | X | X | X | X | X |
| CPU Access | R | R | R | R | R | R | R | R |

Note: R = Read only.

| Bit Position | Value | Description |
|--------------|-------------|--------------------|
| [7:0] RxD | 00h– FFh | Receive data byte. |

UART Interrupt Enable Registers

The UARTx_IER register is used to enable and disable the UART interrupts. The UARTx_IER registers share the same I/O addresses as the UARTx_BRG_H registers. See Table 56.

Table 56. UART Interrupt Enable Registers
(UART0_IER = 00C1h, UART1_IER = 00D1h)

| Bit | 7 | 6 | 5 | 4 | 3 | 2 | 1 | 0 |
|------------|---|---|---|---|-----|-----|-----|-----|
| Reset | 0 | 0 | 0 | 0 | 0 | 0 | 0 | 0 |
| CPU Access | R | R | R | R | R/W | R/W | R/W | R/W |

Note: R = Read only.; R/W = Read/Write.

| Bit Position | Value | Description |
|--------------|--------|--|
| [7:4] | 0000 | Reserved |
| 3 MIIE | 0 1 | Modem interrupt on edge detect of status inputs is disabled. Modem interrupt on edge detect of status inputs is enabled. |
| 2 LSIE | 0 1 | Line status interrupt is disabled. Line status interrupt is enabled for receive data errors: incorrect parity bit received, framing error, overrun error, or break detection. |



| Bit Position | Value | Description |
|--------------|-------|---|
| 1 TIE | 0 | Transmit interrupt is disabled. |
| | 1 | Transmit interrupt is enabled. Interrupt is generated when the transmit FIFO/buffer is empty indicating no more bytes available for transmission. |
| 0 RIE | 0 | Receive interrupt is disabled. |
| | 1 | Receive interrupt and receiver time-out interrupt are enabled. Interrupt is generated if the FIFO/buffer contains data ready to be read or if the receiver times out. |

UART Interrupt Identification Registers

The Read-Only UARTx_IIR register allows the user to check whether the FIFO is enabled and the status of interrupts. These registers share the same I/O addresses as the UARTx_FCTL registers. See Tables 57 and 58.

Table 57. UART Interrupt Identification Registers
(UART0_IIR = 00C2h, UART1_IIR = 00D2h)

| Bit | 7 | 6 | 5 | 4 | 3 | 2 | 1 | 0 |
|------------|---|---|---|---|---|---|---|---|
| Reset | 0 | 0 | 0 | 0 | 0 | 0 | 0 | 1 |
| CPU Access | R | R | R | R | R | R | R | R |

Note: R = Read only.

| Bit Position | Value | Description |
|----------------|-------|---|
| [7:6] FSTS | 00 | FIFO is disabled. |
| | 11 | FIFO is enabled. |
| [5:4] | 00 | Reserved |
| [3:1] INSTS | 000– | Interrupt Status Code The code indicated in these three bits is valid only if INTBIT is 1. If two internal interrupt sources are active and their respective enable bits are High, only the higher priority interrupt is seen by the application. The lower-priority interrupt code is indicated only after the higher-priority interrupt is serviced. Table 58 lists the interrupt status codes. |
| | 110 | |
| 0 INTBIT | 0 | There is an active interrupt source within the UART. |
| | 1 | There is not an active interrupt source within the UART. |



Table 58. UART Interrupt Status Codes

| INSTS Value | Priority | Interrupt Type |
|-------------|----------|-------------------------------------|
| 011 | Highest | Receiver Line Status |
| 010 | Second | Receive Data Ready or Trigger Level |
| 110 | Third | Character Time-out |
| 001 | Fourth | Transmit Buffer Empty |
| 000 | Lowest | Modem Status |

UART FIFO Control Registers

This register is used to monitor trigger levels, clear FIFO pointers, and enable or disable the FIFO. The UARTx_FCTL registers share the same I/O addresses as the UARTx_IIR registers. See Table 59.

Table 59. UART FIFO Control Registers
(UART0_FCTL = 00C2h, UART1_FCTL = 00D2h)

| Bit | 7 | 6 | 5 | 4 | 3 | 2 | 1 | 0 |
|------------|---|---|---|---|---|---|---|---|
| Reset | 0 | 0 | 0 | 0 | 0 | 0 | 0 | 0 |
| CPU Access | W | W | W | W | W | W | W | W |

Note: W = Write only.

| Bit Position | Value | Description |
|---------------|-------|---|
| [7:6] TRIG | 00 | Receive FIFO trigger level set to 1. Receive data interrupt is generated when there is 1 byte in the FIFO. Valid only if FIFO is enabled. |
| | 01 | Receive FIFO trigger level set to 4. Receive data interrupt is generated when there are 4 bytes in the FIFO. Valid only if FIFO is enabled. |
| | 10 | Receive FIFO trigger level set to 8. Receive data interrupt is generated when there are 8 bytes in the FIFO. Valid only if FIFO is enabled. |
| | 11 | Receive FIFO trigger level set to 14. Receive data interrupt is generated when there are 14 bytes in the FIFO. Valid only if FIFO is enabled. |
| [5:3] | 000 | Reserved. |



| Bit Position | Value | Description |
|--------------|-------|--|
| 2 CLRTXF | 0 | No effect. |
| | 1 | Clear the transmit FIFO and reset the transmit FIFO pointer. Valid only if the FIFO is enabled. |
| 1 CLRRXF | 0 | No effect. |
| | 1 | Clear the receive FIFO, clear the receive error FIFO, and reset the receive FIFO pointer. Valid only if the FIFO is enabled. |
| 0 FIFOEN | 0 | Transmit and receive FIFOs are disabled. Transmit and receive buffers are only 1 byte deep. |
| | 1 | Transmit and receive FIFOs are enabled. |

UART Line Control Registers

This register is used to control the communication control parameters. See Tables 60 and 61.

Table 60. UART Line Control Registers
(UART0_LCTL = 00C3h, UART1_LCTL = 00D3h)

| Bit | 7 | 6 | 5 | 4 | 3 | 2 | 1 | 0 |
|------------|-----|-----|-----|-----|-----|-----|-----|-----|
| Reset | 0 | 0 | 0 | 0 | 0 | 0 | 0 | 0 |
| CPU Access | R/W | R/W | R/W | R/W | R/W | R/W | R/W | R/W |

Note: R/W = Read/Write.

| Bit Position | Value | Description |
|--------------|-------|--|
| 7 DLAB | 0 | Access to the UART registers at I/O addresses UARTx_RBR, UARTx_THR, and UARTx_IER is enabled. |
| | 1 | Access to the Baud Rate Generator registers at I/O addresses UARTx_BRG_L and UARTx_BRG_H is enabled. |



| Bit Position | Value | Description |
|---------------|-------------|---|
| 6 SB | 0 | Do not send a BREAK signal. |
| | 1 | Send Break UART sends continuous zeroes on the transmit output from the next bit boundary. The transmit data in the transmit shift register is ignored. After forcing this bit High, the TxD output is 0 only after the bit boundary is reached. Just before forcing TxD to 0, the transmit FIFO is cleared. Any new data written to the transmit FIFO during a break should be written only after the THRE bit of UARTx_LSR register goes High. This new data is transmitted after the UART recovers from the break. After the break is removed, the UART recovers from the break for the next BRG edge. |
| 5 FPE | 0 | Do not force a parity error. |
| | 1 | Force a parity error. When this bit and the party enable bit (PEN) are both 1, an incorrect parity bit is transmitted with the data byte. |
| 4 EPS | 0 | Use odd parity for transmission. The total number of 1 bits in the transmit data plus parity bit is odd. |
| | 1 | Use even parity for transmission. The total number of 1 bits in the transmit data plus parity bit is even. |
| 3 PEN | 0 | Parity bit transmit and receive is disabled. |
| | 1 | Parity bit transmit and receive is enabled. For transmit, a parity bit is generated and transmitted with every data character. For receive, the parity is checked for every incoming data character. |
| [2:0] CHAR | 000– 111 | UART Character Parameter Selection See Table 61 for a description of the values. |

Table 61. UART Character Parameter Definition

| CHAR[2:0] | Character Length (Tx/Rx Data Bits) | Stop Bits (Tx Stop Bits) |
|-----------|---------------------------------------|-----------------------------|
| 000 | 5 | 1 |
| 001 | 6 | 1 |
| 010 | 7 | 1 |
| 011 | 8 | 1 |



Table 61. UART Character Parameter Definition

| CHAR[2:0] | Character Length (Tx/Rx Data Bits) | Stop Bits (Tx Stop Bits) |
|-----------|---------------------------------------|-----------------------------|
| 100 | 5 | 2 |
| 101 | 6 | 2 |
| 110 | 7 | 2 |
| 111 | 8 | 2 |

UART Modem Control Registers

This register is used to control and check the modem status. See Table 62.

Table 62. UART Modem Control Registers
(UART0_MCTL = 00C4h, UART1_MCTL = 00D4h)

| Bit | 7 | 6 | 5 | 4 | 3 | 2 | 1 | 0 |
|------------|---|---|---|-----|-----|-----|-----|-----|
| Reset | 0 | 0 | 0 | 0 | 0 | 0 | 0 | 0 |
| CPU Access | R | R | R | R/W | R/W | R/W | R/W | R/W |

Note: R = Read only.; R/W = Read/Write.

| Bit Position | Value | Description |
|--------------|-------|--|
| [7:5] | 000b | Reserved. |
| 4 LOOP | 0 | LOOP BACK mode is not enabled. |
| | 1 | LOOP BACK mode is enabled. The UART operates in internal LOOP BACK mode. The transmit data output port is disconnected from the internal transmit data output and set to 1. The receive data input port is disconnected and internal receive data is connected to internal transmit data. The modem status input ports are disconnected and the four bits of the modem control register are connected as modem status inputs. The two modem control output ports (OUT1&2) are set to their inactive state |
| 3 OUT2 | 0–1 | No function in normal operation. In LOOP BACK mode, this bit is connected to the DCD bit in the UART Status Register. |



| Bit Position | Value | Description |
|--------------|-------|--|
| 2 OUT1 | 0–1 | No function in normal operation. In LOOP BACK mode, this bit is connected to the RI bit in the UART Status Register. |
| 1 RTS | 0–1 | Request to Send. _____ In normal operation, the RTS output port is the inverse of this bit. In LOOP BACK mode, this bit is connected to the CTS bit in the UART Status Register. |
| 0 DTR | 0–1 | Data Terminal Ready. _____ In normal operation, the DTR output port is the inverse of this bit. In LOOP BACK mode, this bit is connected to the DSR bit in the UART Status Register. |

UART Line Status Registers

This register is used to show the status of UART interrupts and registers. See Table 63.

Table 63. UART Line Status Registers
(UART0_LSR = 00C5h, UART1_LSR = 00D5h)

| Bit | 7 | 6 | 5 | 4 | 3 | 2 | 1 | 0 |
|------------|---|---|---|---|---|---|---|---|
| Reset | 0 | 1 | 1 | 0 | 0 | 0 | 0 | 0 |
| CPU Access | R | R | R | R | R | R | R | R |

Note: R = Read only.

| Bit Position | Value | Description |
|--------------|-------|--|
| 7 ERR | 0 | Always 0 when operating with the FIFO disabled. With the FIFO enabled, this bit is reset when the UARTx_LSR register is read and there are no more bytes with error status in the FIFO. |
| | 1 | Error detected in the FIFO. There is at least 1 parity, framing or break indication error in the FIFO. |
| 6 TEMT | 0 | Transmit holding register/FIFO is not empty or transmit shift register is not empty or transmitter is not idle. |
| | 1 | Transmit holding register/FIFO and transmit shift register are empty; and the transmitter is idle. This bit cannot be set to 1 during the BREAK condition. This bit only becomes 1 after the BREAK command is removed. |



| Bit Position | Value | Description |
|--------------|-------|---|
| 5 THRE | 0 | Transmit holding register/FIFO is not empty. |
| | 1 | Transmit holding register/FIFO is empty. This bit cannot be set to 1 during the BREAK condition. This bit only becomes 1 after the BREAK command is removed. |
| 4 BI | 0 | Receiver does not detect a BREAK condition. This bit is reset to 0 when the UARTx_LSR register is read. |
| | 1 | Receiver detects a BREAK condition on the receive input line. This bit is 1 if the duration of BREAK condition on the receive data is longer than one character transmission time, the time depends on the programming of the UARTx_LSR register. In case of FIFO only one null character is loaded into the receiver FIFO with the framing error. The framing error is revealed to the eZ80 [®] whenever that particular data is read from the receiver FIFO. |
| 3 FE | 0 | No framing error detected for character at the top of the FIFO. This bit is reset to 0 when the UARTx_LSR register is read. |
| | 1 | Framing error detected for the character at the top of the FIFO. This bit is set to 1 when the stop bit following the data/parity bit is logic 0. |
| 2 PE | 0 | The received character at the top of the FIFO does not contain a parity error. This bit is reset to 0 when the UARTx_LSR register is read. |
| | 1 | The received character at the top of the FIFO contains a parity error. |
| 1 OE | 0 | The received character at the top of the FIFO does not contain an overrun error. This bit is reset to 0 when the UARTx_LSR register is read. |
| | 1 | Overrun error is detected. If the FIFO is not enabled, this indicates that the data in the receive buffer register was not read before the next character was transferred into the receiver buffer register. If the FIFO is enabled, this indicates the FIFO was already full when an additional character was received by the receiver shift register. The character in the receiver shift register is not put into the receiver FIFO. |



| Bit Position | Value | Description |
|--------------|-------|--|
| 0 DR | 0 | This bit is reset to 0 when the UARTx_RBR register is read or all bytes are read from the receiver FIFO. |
| | 1 | Data ready. If the FIFO is not enabled, this bit is set to 1 when a complete incoming character is transferred into the receiver buffer register from the receiver shift register. If the FIFO is enabled, this bit is set to 1 when a character is received and transferred to the receiver FIFO. |

UART Modem Status Registers

This register is used to show the status of the UART signals. See Table 64.

Table 64. UART Modem Status Registers
(UART0_MSR = 00C6h, UART1_MSR = 00D6h)

| Bit | 7 | 6 | 5 | 4 | 3 | 2 | 1 | 0 |
|------------|---|---|---|---|---|---|---|---|
| Reset | X | X | X | X | X | X | X | X |
| CPU Access | R | R | R | R | R | R | R | R |

Note: R = Read only.

| Bit Position | Value | Description |
|--------------|-------|---|
| 7 DCD | 0–1 | Data Carrier Detect In NORMAL mode, this bit reflects the inverted state of the DCDx input pin. In LOOP BACK mode, this bit reflects the value of the UARTx_MCTL[3] = out2. |
| 6 RI | 0–1 | Ring Indicator In NORMAL mode, this bit reflects the inverted state of the RIx input pin. In LOOP BACK mode, this bit reflects the value of the UARTx_MCTL[2] = out1. |
| 5 DSR | 0–1 | Data Set Ready In NORMAL mode, this bit reflects the inverted state of the DSRx input pin. In LOOP BACK mode, this bit reflects the value of the UARTx_MCTL[0] = DTR. |
| 4 CTS | 0–1 | Clear to Send In NORMAL mode, this bit reflects the inverted state of the CTSx input pin. In LOOP BACK mode, this bit reflects the value of the UARTx_MCTL[1] = RTS. |



| Bit Position | Value | Description |
|--------------|-------|--|
| 3 DDCD | 0–1 | Delta Status Change of DCD _____ This bit is set to 1 whenever the DCDx pin changes state. This bit is reset to 0 when the UARTx_MSR register is read. |
| 2 TERI | 0–1 | Trailing Edge Change on RI. _____ This bit is set to 1 whenever a falling edge is detected on the RIx pin. This bit is reset to 0 when the UARTx_MSR register is read. |
| 1 DDSR | 0–1 | Delta Status Change of DSR _____ This bit is set to 1 whenever the DSRx pin changes state. This bit is reset to 0 when the UARTx_MSR register is read. |
| 0 DCTS | 0–1 | Delta Status Change of CTS _____ This bit is set to 1 whenever the CTSx pin changes state. This bit is reset to 0 when the UARTx_MSR register is read. |

UART Scratch Pad Registers

The UARTx_SPR register can be used by the system as a general-purpose Read/Write register. See Table 65.

Table 65. UART Scratch Pad Registers
(UART0_SPR = 00C7h, UART1_SPR = 00D7h)

| Bit | 7 | 6 | 5 | 4 | 3 | 2 | 1 | 0 |
|------------|-----|-----|-----|-----|-----|-----|-----|-----|
| Reset | 0 | 0 | 0 | 0 | 0 | 0 | 0 | 0 |
| CPU Access | R/W | R/W | R/W | R/W | R/W | R/W | R/W | R/W |

Note: R/W = Read/Write.

| Bit Position | Value | Description |
|--------------|-------------|--|
| [7:0] SPR | 00h– FFh | UART scratch pad register is available for use as a general-purpose Read/Write register. |

Infrared Encoder/Decoder

The eZ80L92 contains a UART to infrared encoder/decoder (endec). The infrared encoder/decoder is integrated with the on-chip UART0 to allow easy communication between the eZ80[®] CPU and IrDA Physical Layer Specification Version 1.3 compliant infrared transceivers as illustrated in Figure 24. Infrared communication provides secure, reliable, high-speed, low-cost, point-to-point communication between PCs, PDAs, mobile telephones, printers and other infrared enabled devices.

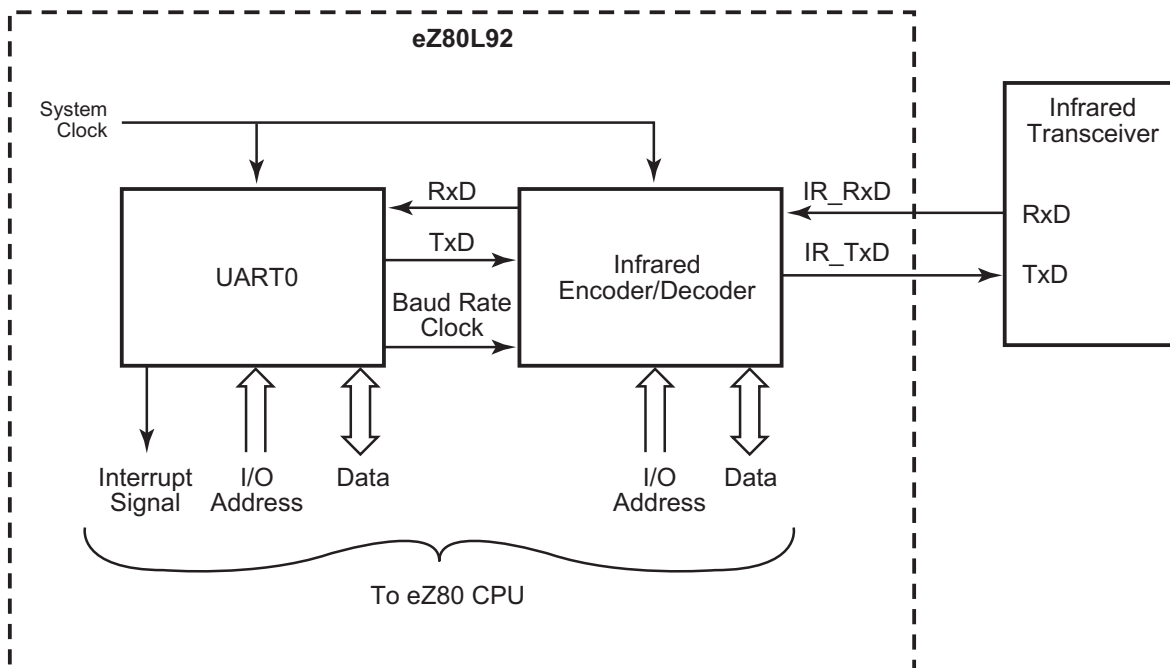

Figure 24. Infrared System Block Diagram

Functional Description

When the infrared encoder/decoder is enabled, the transmit data from the on-chip UART is encoded as digital signals in accordance with the IrDA standard and output to the infrared transceiver. Likewise, data received from the infrared transceiver is decoded by the infrared encoder/decoder and passed to the UART. Communication is half-duplex meaning that simultaneous data transmission and reception is not allowed.

The baud rate is set by the UART Baud Rate Generator and supports IrDA standard baud rates from 9600 bits/s to 115.2 KBPS. Higher baud rates are possible, but do not meet IrDA specifications. The UART must be enabled to use the infrared encoder/decoder. Refer to the section covering the [Universal Asynchronous Receiver/Transmitter](#), on page 102, for more information on the UART and its Baud Rate Generator.

Transmit

The data to be transmitted via the IR transceiver is first sent to UART0. The UART transmit signal (TxD) and Baud Rate Clock are used by the infrared encoder/decoder to generate the modulation signal (IR_TXD) that drives the infrared transceiver. Each UART bit is 16-clocks wide. If the data to be transmitted is a logical 1 (High), the IR_TXD signal remains Low (0) for the full 16-clock period. If the data to be transmitted is a logical 0, a 3-clock High (1) pulse is output following a 7-clock Low (0) period. Following the 3-clock High pulse, a 6-clock Low pulse completes the full 16-clock data period. Data transmission is illustrated in Figure 25. During data transmission, the IR receive function should be disabled by clearing the IR_RXEN bit in the IR_CTL reg to 0. This prevents transmitter to receiver cross-talk.

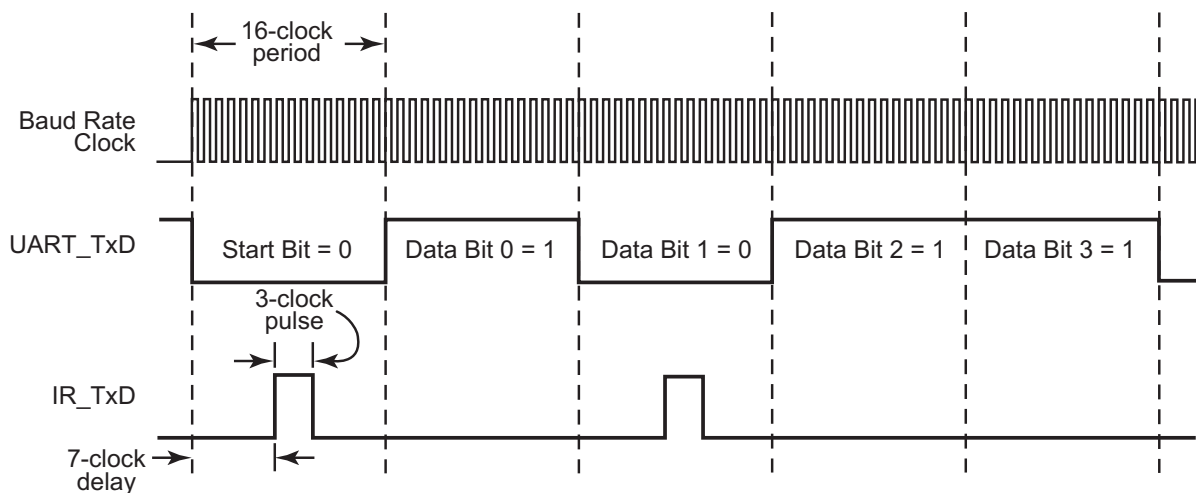

Figure 25. Infrared Data Transmission

Receive

Data received from the IR transceiver via the IR_RXD signal is decoded by the infrared encoder/decoder and passed to the UART. The IR_RXEN bit in the IR_CTL register must be set to enable the receiver decoder. The SIR data format

uses half duplex communication therefore the UART should not be allowed to transmit while the receiver decoder is enabled. The UART Baud Rate Clock is used by the infrared encoder/decoder to generate the demodulated signal (RxD) that drives the UART. Each UART bit is 16-clocks wide. If the data to be received is a logical 1 (High), the IR_RXD signal remains High (1) for the full 16-clock period. If the data to be received is a logical 0, a 3-clock Low (0) pulse is output following a 7-clock High (1) period. Following the 3-clock Low pulse, is a 6-clock High pulse to complete the full 16-clock data period. Data transmission is illustrated in Figure 26.

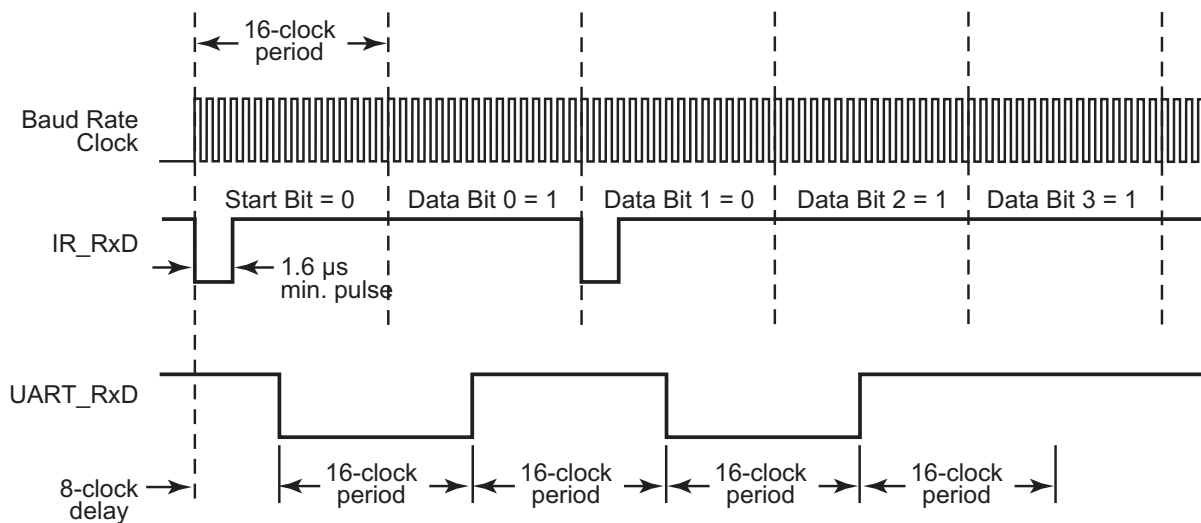

Figure 26. Infrared Data Reception

Jitter

Due to the inherent sampling of the received IR_RXD signal by the Bit Rate Clock, some jitter can be expected on the first bit in any sequence of data. However, all subsequent bits in the received data stream are a fixed 16-clock periods wide.

Infrared Encoder/Decoder Signal Pins

The infrared encoder/decoder signal pins (IR_TXD and IR_RXD) are multiplexed with General-Purpose I/O (GPIO) pins. These GPIO pins must be configured for alternate function operation for the infrared encoder/decoder to operate.

The remaining six UART0 pins ($\overline{\text{CTS0}}$, $\overline{\text{DCD0}}$, $\overline{\text{DSR0}}$, $\overline{\text{DTR0}}$, $\overline{\text{RTS0}}$ and $\overline{\text{RI0}}$) are not required for use with the infrared encoder/decoder. The UART0 modem status interrupt should be disabled to prevent unwanted interrupts from these pins. The



GPIO pins corresponding to these six unused UART0 pins can be used for inputs, outputs, or interrupt sources. Recommended GPIO Port D control register settings are provided in Table 66. Refer to the section covering the [General-Purpose Input/Output](#), on page 39 for additional information on setting the GPIO Port modes

Table 66. GPIO Mode Selection when using the IrDA Encoder/Decoder

| GPIO Port D Bits | Allowable GPIO Port Mode | Allowable Port Mode Functions |
|------------------|--|--|
| PD0 | 7 | Alternate Function |
| PD1 | 7 | Alternate Function |
| PD2–PD7 | Any other than GPIO Mode 7 (1, 2, 3, 4, 5, 6, 8, or 9) | Output, Input, Open-Drain, Open-Source, Level-sensitive Interrupt Input, or Edge-Triggered Interrupt Input |

Loopback Testing

Both internal and external loopback testing can be accomplished with the endec on the eZ80L92. Internal loopback testing is enabled by setting the LOOP_BACK bit to 1. During internal loopback, IR_TXD output signal is inverted and connected on-chip to the IR_RXD input. External loopback testing of the off-chip IrDA transceiver may be accomplished by transmitting data from the UART while the receiver is enabled (IR_RXEN set to 1).

Infrared Encoder/Decoder Register

After a RESET, the infrared encoder/decoder register is set to its default value. Any writes to unused register bits are ignored and reads return a value of 0. Unused bits within a register must always be written with a value of 0. The IR_CTL register is described in Table 67.



Table 67. Infrared Encoder/Decoder Control Register (IR_CTL = 00BFh)

| Bit | 7 | 6 | 5 | 4 | 3 | 2 | 1 | 0 |
|------------|-----|-----|-----|-----|-----|-----|-----|-----|
| Reset | 0 | 0 | 0 | 0 | 0 | 0 | 0 | 0 |
| CPU Access | R/W | R/W | R/W | R/W | R/W | R/W | R/W | R/W |

Note: R = Read only; R/W = Read/Write.

| Bit Position | Value | Description |
|----------------|--------|--|
| [7:3] | 000000 | Reserved. |
| 2 LOOP_BACK | 0 1 | Internal LOOP BACK mode is disabled. Internal LOOP BACK mode is enabled. IR_TXD output is inverted and connected to IR_RXD input for internal loop back testing. |
| 1 IR_RXEN | 0 1 | IR_RXD data is ignored. IR_RXD data is passed to UART0 RxD. |
| 0 IR_EN | 0 1 | Infrared Encoder/Decoder is disabled. Infrared Encoder/Decoder is enabled. |

Serial Peripheral Interface

The Serial Peripheral Interface (SPI) is a synchronous interface allowing several SPI-type devices to be interconnected. The SPI is a full-duplex, synchronous, character-oriented communication channel that employs a four-wire interface. The SPI block consists of a transmitter, receiver, baud rate generator, and control unit. During an SPI transfer, data is sent and received simultaneously by both the master and the slave SPI devices.

In a serial peripheral interface, separate signals are required for data and clock. The SPI may be configured as either a master or a slave. The connection of two SPI devices (one master and one slave) and the direction of data transfer is demonstrated in Figures 27 and 28.

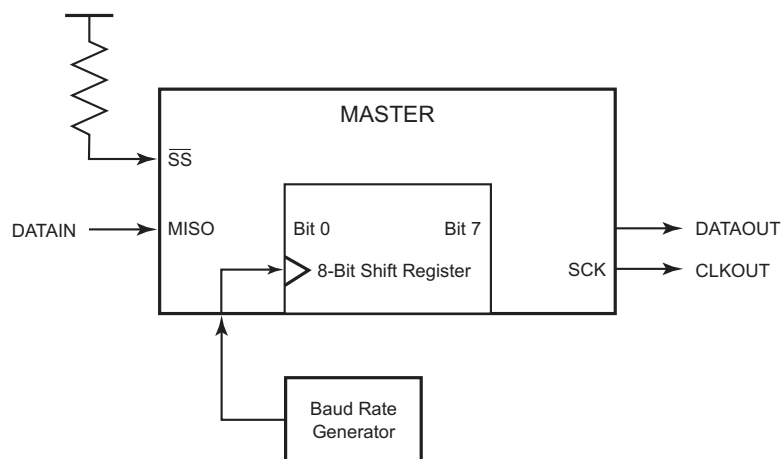

Figure 27. SPI Master Device

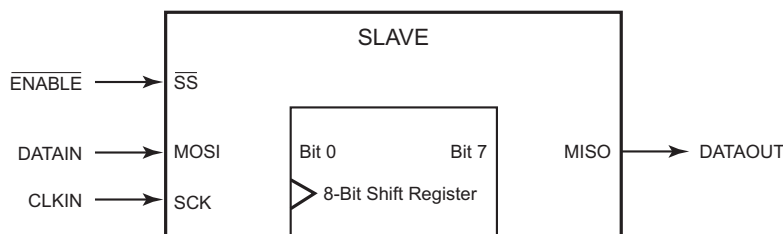

Figure 28. SPI Slave Device



SPI Signals

The four basic SPI signals are:

- MISO (Master-In, Slave-Out)
- MOSI (Master-Out, Slave-In)
- SCK (SPI Serial Clock)
- \overline{SS} (Slave Select)

These SPI signals are discussed in the following paragraphs. Each signal is described in both MASTER and SLAVE modes.

Master-In, Slave-Out

The Master-In, Slave-Out (MISO) pin is configured as an input in a master device and as an output in a slave device. It is one of the two lines that transfer serial data, with the most significant bit sent first. The MISO pin of a slave device is placed in a high-impedance state if the slave is not selected. When the SPI is not enabled, this signal is in a high-impedance state.

Master-Out, Slave-In

The Master-Out, Slave-In (MOSI) pin is configured as an output in a master device and as an input in a slave device. It is one of the two lines that transfer serial data, with the most significant bit sent first. When the SPI is not enabled, this signal is in a high-impedance state.

Slave Select

The active Low Slave Select (\overline{SS}) input signal is used to select the SPI as a slave device. It must be Low prior to all data communication and must stay Low for the duration of the data transfer.

The \overline{SS} input signal must be High for the SPI to operate as a master device. If the \overline{SS} signal goes Low, a Mode Fault error flag (MODF) is set in the SPI_SR register. See the [SPI Status Register](#) (SPI_SR) on page 133 for more information.

When CPHA (Clock Phase) is set to 0, the shift clock is the logical OR of \overline{SS} with SCK. In this clock phase mode, \overline{SS} must go High between successive characters in an SPI message. When CPHA is set to 1, \overline{SS} can remain Low for several SPI characters. In cases where there is only one SPI slave, its \overline{SS} line could be tied Low as long as CPHA is set to 1. See the [SPI Control Register](#) (SPI_CTL) on page 132 for more information on CPHA.

Serial Clock

The Serial Clock (SCK) is used to synchronize data movement both in and out of the device through its MOSI and MISO pins. The master and slave are each capa-

ble of exchanging a byte of data during a sequence of eight clock cycles. Because SCK is generated by the master, the SCK pin becomes an input on a slave device. The SPI contains an internal divide-by-two clock divider. In MASTER mode, the SPI serial clock is one-half the frequency of the clock signal created by the SPI's Baud Rate Generator.

As demonstrated in Figure 29 and Table 68, four possible timing relations may be chosen by using control bits CPOL and CPHA in the SPI Control register. See the [SPI Control Register](#) (SPI_CTL) on page 132. Both the master and slave must operate with the identical timing, CPOL (Clock Polarity), and CPHA. The master device always places data on the MOSI line a half-cycle before the clock edge (SCK signal), in order for the slave device to latch the data.

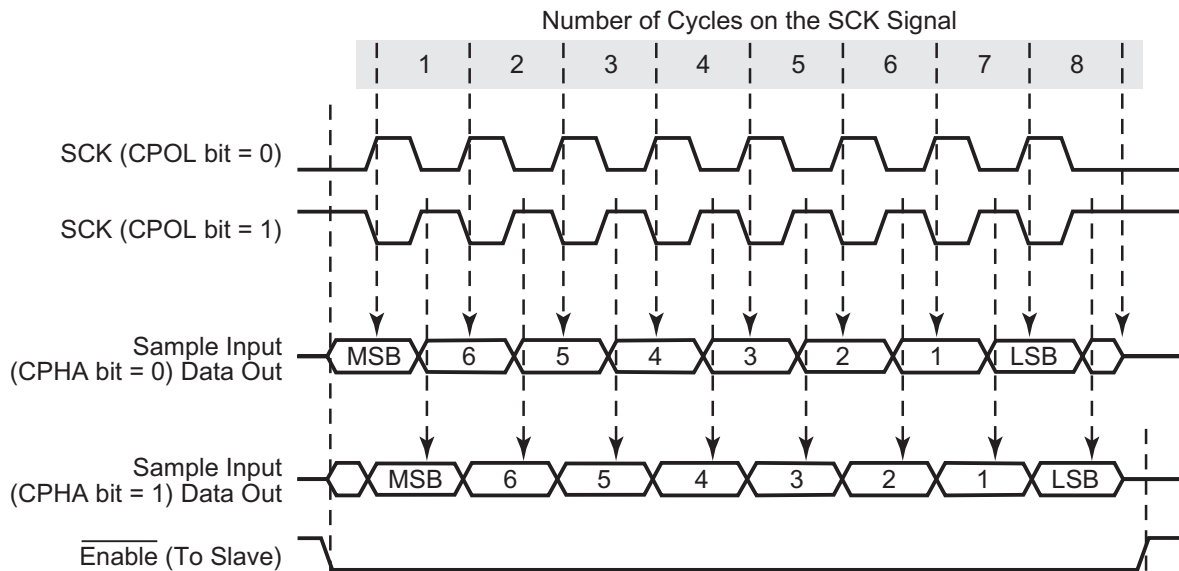

Figure 29. SPI Timing

Table 68. SPI Clock Phase (CPHA) and Clock Polarity (CPOL) Operation

| CPHA | CPOL | SCK Transmit Edge | SCK Receive Edge | SCK Idle State | SS High Between Characters? |
|------|------|-------------------|------------------|----------------|-----------------------------|
| 0 | 0 | Falling | Rising | Low | Yes |
| 0 | 1 | Rising | Falling | High | Yes |
| 1 | 0 | Rising | Falling | Low | No |
| 1 | 1 | Falling | Rising | High | No |



SPI Functional Description

When a master transmits to a slave device via the MOSI signal, the slave device responds by sending data to the master via the master's MISO signal. The resulting implication is a full-duplex transmission, with both data out and data in synchronized with the same clock signal. Thus the byte transmitted is replaced by the byte received and eliminates the requirement for separate transmit-empty and receive-full status bits. A single status bit, SPIF, is used to signify that the I/O operation is completed, see the [SPI Status Register](#) (SPI_SR) on page 133.

The SPI is double-buffered on Read, but not on Write. If a Write is performed during data transfer, the transfer occurs uninterrupted, and the Write is unsuccessful. This condition causes the WRITE COLLISION (WCOL) status bit in the SPI_SR register to be set. After a data byte is shifted, the SPIF flag of the SPI_SR register is set.

In SPI MASTER mode, the SCK pin is an output. It idles High or Low, depending on the CPOL bit in the SPI_CTL register, until data is written to the shift register. Data transfer is initiated by writing to the transmit shift register, SPI_TSR. Eight clocks are then generated to shift the eight bits of transmit data out the MOSI pin while shifting in eight bits of data on the MISO pin. After transfer, the SCK signal idles.

In SPI SLAVE mode, the start logic receives a logic Low from the \overline{SS} pin and a clock input at the SCK pin, and the slave is synchronized to the master. Data from the master is received serially from the slave MOSI signal and loads the 8-bit shift register. After the 8-bit shift register is loaded, its data is parallel transferred to the Read buffer. During a Write cycle data is written into the shift register, then the slave waits for the SPI master to initiate a data transfer, supply a clock signal, and shift the data out on the slave's MISO signal.

If the CPHA bit in the SPI_CTL register is 0, a transfer begins when \overline{SS} pin signal goes Low and the transfer ends when \overline{SS} goes High after eight clock cycles on SCK. When the CPHA bit is set to 1, a transfer begins the first time SCK becomes active while \overline{SS} is Low and the transfer ends when the SPIF flag gets set.

SPI Flags

Mode Fault

The Mode Fault flag (MODF) indicates that there may be a multimaster conflict for system control. The MODF bit is normally cleared to 0 and is only set to 1 when the master device's SS pin is pulled Low. When a mode fault is detected, the following occurs:

1. The MODF flag (SPI_SR[4]) is set to 1.
2. The SPI device is disabled by clearing the SPI_EN bit (SPI_CTL[5]) to 0.



3. The MASTER_EN bit (SPI_CTL[4]) is cleared to 0, forcing the device into SLAVE mode.
4. If the SPI interrupt is enabled by setting IRQ_EN (SPI_CTL[7]) High, an SPI interrupt is generated.

Clearing the Mode Fault flag is performed by reading the SPI Status register. The other SPI control bits (SPI_EN and MASTER_EN) must be restored to their original states by user software after the Mode Fault flag is cleared.

Write Collision

The WRITE COLLISION flag, WCOL (SPI_SR[5]), is set to 1 when an attempt is made to write to the SPI Transmit Shift register (SPI_TSR) while data transfer occurs. Clearing the WCOL bit is performed by reading SPI_SR with the WCOL bit set.

SPI Baud Rate Generator

The SPI's Baud Rate Generator creates a lower frequency clock from the high-frequency system clock. The Baud Rate Generator output is used as the clock source by the SPI.

Baud Rate Generator Functional Description

The SPI's Baud Rate Generator consists of a 16-bit downcounter, two 8-bit registers, and associated decoding logic. The Baud Rate Generator's initial value is defined by the two BRG Divisor Latch registers, {SPI_BRG_H, SPI_BRG_L}. At the rising edge of each system clock, the BRG decrements until it reaches the value 0001h. On the next system clock rising edge, the BRG reloads the initial value from {SPI_BRG_H, SPI_BRG_L} and outputs a pulse to indicate the end-of-count. Calculate the SPI Data Rate with the following equation:

$$\text{SPI Data Rate (bits/s)} = \frac{\text{System Clock Frequency}}{2 \times \text{SPI Baud Rate Generator Divisor}}$$

Upon RESET, the 16-bit BRG divisor value resets to 0002h. When the SPI is operating as a Master, the BRG divisor value must be set to a value of 0003h or greater. When the SPI is operating as a Slave, the BRG divisor value must be set to a value of 0004h or greater. A software Write to either the Low- or High-byte registers for the BRG Divisor Latch causes both the Low and High bytes to load into the BRG counter, and causes the count to restart.



Data Transfer Procedure with SPI Configured as the Master

1. Load the SPI Baud Rate Generator Registers, SPI_BRG_H and SPI_BRG_L.
2. External device must deassert the \overline{SS} pin if currently asserted.
3. Load the SPI Control Register, SPI_CTL.
4. Assert the \overline{ENABLE} pin of the slave device using a GPIO pin.
5. Load the SPI Transmit Shift Register, SPI_TSR.
6. When the SPI data transfer is complete, deassert the \overline{ENABLE} pin of the slave device.

Data Transfer Procedure with SPI Configured as a Slave

1. Load the SPI Baud Rate Generator Registers, SPI_BRG_H and SPI_BRG_L.
2. Load the SPI Transmit Shift Register, SPI_TSR. This load cannot occur while the SPI slave is currently receiving data.
3. Wait for the external SPI Master device to initiate the data transfer by asserting SS.

SPI Registers

There are six registers in the Serial Peripheral Interface which provide control, status, and data storage functions. The SPI registers are described in the following paragraphs.

SPI Baud Rate Generator Registers—Low Byte and High Byte

These registers hold the Low and High bytes of the 16-bit divisor count loaded by the processor for baud rate generation. The 16-bit clock divisor value is returned by {SPI_BRG_H, SPI_BRG_L}. Upon RESET, the 16-bit BRG divisor value resets to 0002h. When configured as a Master, the 16-bit divisor value must be between 0003h and FFFFh, inclusive. When configured as a Slave, the 16-bit divisor value must be between 0004h and FFFFh, inclusive.

A Write to either the Low or High byte registers for the BRG Divisor Latch causes both bytes to be loaded into the BRG counter and the count restarted. See Tables 69 and 70.

**Table 69. SPI Baud Rate Generator Register—Low Byte (SPI_BRG_L = 00B8h)**

| Bit | 7 | 6 | 5 | 4 | 3 | 2 | 1 | 0 |
|------------|-----|-----|-----|-----|-----|-----|-----|-----|
| Reset | 0 | 0 | 0 | 0 | 0 | 0 | 1 | 0 |
| CPU Access | R/W | R/W | R/W | R/W | R/W | R/W | R/W | R/W |

Note: R/W = Read/Write.

| Bit Position | Value | Description |
|--------------------|-------------|--|
| [7:0] SPI_BRG_L | 00h– FFh | These bits represent the Low byte of the 16-bit Baud Rate Generator divider value. The complete BRG divisor value is returned by {SPI_BRG_H, SPI_BRG_L}. |

Table 70. SPI Baud Rate Generator Register—High Byte (SPI_BRG_H = 00B9h)

| Bit | 7 | 6 | 5 | 4 | 3 | 2 | 1 | 0 |
|------------|-----|-----|-----|-----|-----|-----|-----|-----|
| Reset | 0 | 0 | 0 | 0 | 0 | 0 | 0 | 0 |
| CPU Access | R/W | R/W | R/W | R/W | R/W | R/W | R/W | R/W |

Note: R/W = Read/Write.

| Bit Position | Value | Description |
|--------------------|-------------|---|
| [7:0] SPI_BRG_H | 00h– FFh | These bits represent the High byte of the 16-bit Baud Rate Generator divider value. The complete BRG divisor value is returned by {SPI_BRG_H, SPI_BRG_L}. |



SPI Control Register

This register is used to control and setup the serial peripheral interface. The SPI should be disabled prior to making any changes to CPHA or CPOL. See Table 71.

Table 71. SPI Control Register (SPI_CTL = 00BAh)

| | | | | | | | | |
|--|-----|---|-----|-----|-----|-----|---|---|
| Bit | 7 | 6 | 5 | 4 | 3 | 2 | 1 | 0 |
| Reset | 0 | 0 | 0 | 0 | 0 | 1 | 0 | 0 |
| CPU Access | R/W | R | R/W | R/W | R/W | R/W | R | R |
| Note: R = Read Only; R/W = Read/Write. | | | | | | | | |

| Bit Position | Value | Description |
|--------------|-------|---|
| 7 | 0 | SPI system interrupt is disabled. |
| IRQ_EN | 1 | SPI system interrupt is enabled. |
| 6 | 0 | Reserved. |
| 5 | 0 | SPI is disabled. |
| SPI_EN | 1 | SPI is enabled. |
| 4 | 0 | When enabled, the SPI operates as a slave. |
| MASTER_EN | 1 | When enabled, the SPI operates as a master. |
| 3 | 0 | Master SCK pin idles in a Low (0) state. |
| CPOL | 1 | Master SCK pin idles in a High (1) state. |
| 2 | 0 | SS must go High after transfer of every byte of data. |
| CPHA | 1 | SS can remain Low to transfer any number of data bytes. |
| [1:0] | 00 | Reserved. |



SPI Status Register

The SPI Status Read-Only register returns the status of data transmitted using the serial peripheral interface. Reading the SPI_SR register clears Bits 7, 6, and 4 to a logical 0. See Table 72.

Table 72. SPI Status Register (SPI_SR = 00BBh)

| | | | | | | | | |
|----------------------|---|---|---|---|---|---|---|---|
| Bit | 7 | 6 | 5 | 4 | 3 | 2 | 1 | 0 |
| Reset | 0 | 0 | 0 | 0 | 0 | 0 | 0 | 0 |
| CPU Access | R | R | R | R | R | R | R | R |
| Note: R = Read Only. | | | | | | | | |

| Bit Position | Value | Description |
|--------------|-------|---|
| 7 SPIF | 0 | SPI data transfer is not finished. |
| | 1 | SPI data transfer is finished. If enabled, an interrupt is generated. This bit flag is cleared to 0 by a Read of the SPI_SR register. |
| 6 WCOL | 0 | An SPI write collision is not detected. |
| | 1 | An SPI write collision is detected. This bit flag is cleared to 0 by a Read of the SPI_SR registers. |
| 5 | 0 | Reserved. |
| 4 MODF | 0 | A mode fault (multimaster conflict) is not detected. |
| | 1 | A mode fault (multimaster conflict) is detected. This bit flag is cleared to 0 by a Read of the SPI_SR register. |
| [3:0] | 0000 | Reserved. |

SPI Transmit Shift Register

The SPI Transmit Shift register (SPI_TSR) is used by the SPI master to transmit data onto the SPI serial bus to the slave device. A Write to the SPI_TSR register places data directly into the shift register for transmission. A Write to this register within an SPI device configured as a master initiates transmission of the byte of the data loaded into the register. At the completion of transmitting a byte of data, the SPIF status bit (SPI_SR[7]) is set to 1 in both the master and slave devices.

The SPI Transmit Shift Write-Only register shares the same address space as the SPI Receive Buffer Read-Only register. See Table 73.

**Table 73. SPI Transmit Shift Register (SPI_TSR = 00BCh)**

| | | | | | | | | |
|------------|---|---|---|---|---|---|---|---|
| Bit | 7 | 6 | 5 | 4 | 3 | 2 | 1 | 0 |
| Reset | X | X | X | X | X | X | X | X |
| CPU Access | W | W | W | W | W | W | W | W |

Note: W = Write only.

| Bit Position | Value | Description |
|------------------|-------------|--------------------|
| [7:0] TX_DATA | 00h– FFh | SPI transmit data. |

SPI Receive Buffer Register

The SPI Receive Buffer register (SPI_RBR) is used by the SPI slave to receive data from the serial bus. The SPIF bit must be cleared prior to a second transfer of data from the shift register or an overrun condition exists. In cases of overrun the byte that caused the overrun is lost.

The SPI Receive Buffer Read-Only register shares the same address space as the SPI Transmit Shift Write-Only register. See Table 74.

Table 74. SPI Receive Buffer Register (SPI_RBR = 00BCh)

| | | | | | | | | |
|------------|---|---|---|---|---|---|---|---|
| Bit | 7 | 6 | 5 | 4 | 3 | 2 | 1 | 0 |
| Reset | X | X | X | X | X | X | X | X |
| CPU Access | R | R | R | R | R | R | R | R |

Note: R = Read Only.

| Bit Position | Value | Description |
|------------------|-------------|--------------------|
| [7:0] RX_DATA | 00h– FFh | SPI received data. |



I²C Serial I/O Interface

I²C General Characteristics

The I²C serial I/O bus is a two-wire communication interface that can operate in four modes:

- MASTER TRANSMIT
- MASTER RECEIVE
- SLAVE TRANSMIT
- SLAVE RECEIVE

The I²C interface consists of the Serial Clock (SCL) and the Serial Data (SDA). Both SDA and SCL are bidirectional lines, connected to a positive supply voltage via an external pull-up resistor. When the bus is free, both lines are High. The output stages of devices connected to the bus must be configured as open-drain outputs. Data on the I²C bus can be transferred at a rate of up to 100 KBPS in STANDARD mode, or up to 400 KBPS in FAST mode. One clock pulse is generated for each data bit transferred.

Clocking Overview

If another device on the I²C bus drives the clock line when the I²C is in MASTER mode, the I²C synchronizes its clock to the I²C bus clock. The High period of the clock is determined by the device that generates the shortest High clock period. The Low period of the clock is determined by the device that generates the longest Low clock period.

A slave may stretch the Low period of the clock to slow down the bus master. The Low period may also be stretched for handshaking purposes. This can be done after each bit transfer or each byte transfer. The I²C stretches the clock after each byte transfer until the IFLG bit in the I2C_CTL register is cleared.

Bus Arbitration Overview

In MASTER mode, the I²C checks that each transmitted logic 1 appears on the I²C bus as a logic 1. If another device on the bus overrules and pulls the SDA signal Low, arbitration is lost. If arbitration is lost during the transmission of a data byte or a Not-Acknowledge bit, the I²C returns to the idle state. If arbitration is lost during the transmission of an address, the I²C switches to SLAVE mode so that it can recognize its own slave address or the general call address.

Data Validity

The data on the SDA line must be stable during the High period of the clock. The High or Low state of the data line can only change when the clock signal on the SCL line is Low as illustrated in Figure 30.

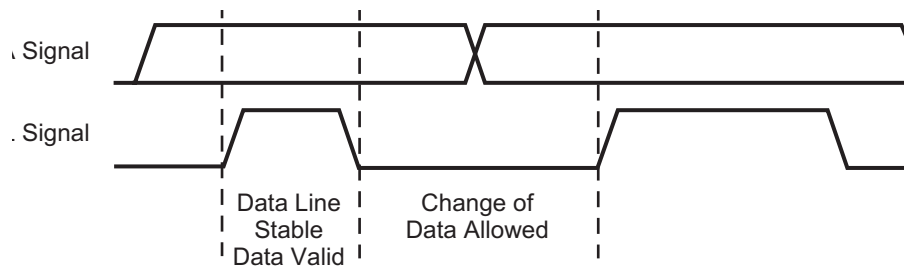

Figure 30. I²C Clock and Data Relationship

START and STOP Conditions

Within the I²C bus protocol, unique situations arise which are defined as START and STOP conditions. See Figure 31. A High-to-Low transition on the SDA line while SCL is High indicates a START condition. A Low-to-High transition on the SDA line while SCL is High defines a STOP condition.

START and STOP conditions are always generated by the master. The bus is considered to be busy after the START condition. The bus is considered to be free a defined time after the STOP condition.

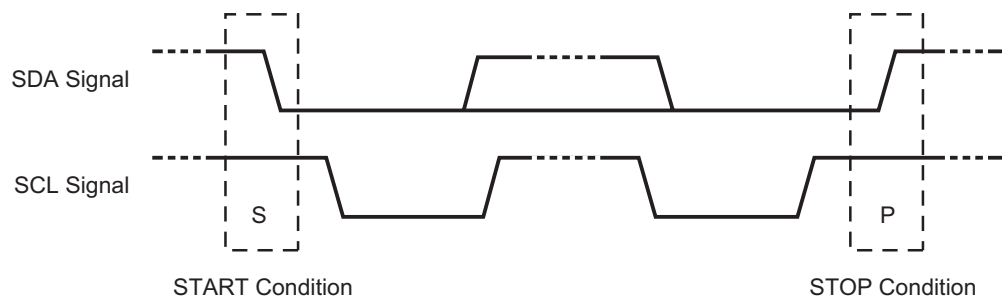

Figure 31. START and STOP Conditions In I²C Protocol

Transferring Data

Byte Format

Every character transferred on the SDA line must be a single 8-bit byte. The number of bytes that can be transmitted per transfer is unrestricted. Each byte must be followed by an Acknowledge (ACK)¹. Data is transferred with the most significant bit (msb) first. See Figure 32. A receiver can hold the SCL line Low to force the transmitter into a wait state. Data transfer then continues when the receiver is ready for another byte of data and releases SCL.

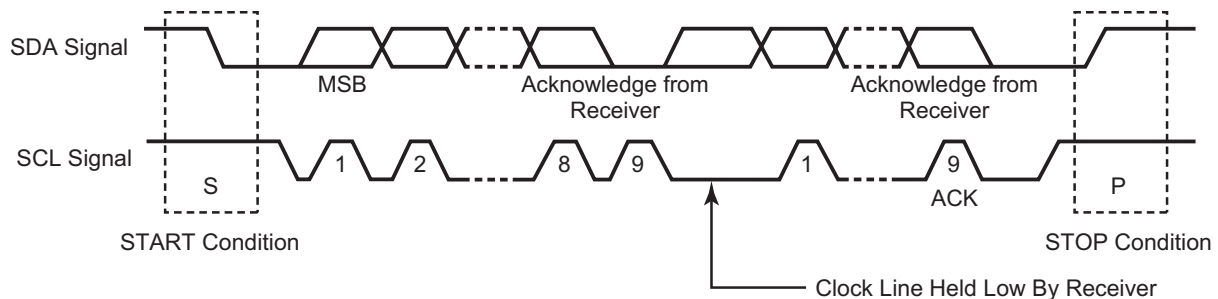

Figure 32. I²C Frame Structure

Acknowledge

Data transfer with an ACK function is obligatory. The ACK-related clock pulse is generated by the master. The transmitter releases the SDA line (High) during the ACK clock pulse. The receiver must pull down the SDA line during the ACK clock pulse so that it remains stable Low during the High period of this clock pulse. See Figure 33.

A receiver that is addressed is obliged to generate an ACK after each byte is received. When a slave-receiver doesn't acknowledge the slave address (for example, unable to receive because it's performing some real-time function), the data line must be left High by the slave. The master then generates a STOP condition to abort the transfer.

If a slave-receiver acknowledges the slave address, but cannot receive any more data bytes, the master must abort the transfer. The abort is indicated by the slave generating the Not Acknowledge (NACK) on the first byte to follow. The slave leaves the data line High and the master generates the STOP condition.

1. ACK is defined as a general Acknowledge bit. By contrast, the I²C Acknowledge bit is represented as AAK, bit 2 of the I²C Control Register, which identifies which ACK signal to transmit. See [Table 84](#) on page 151.

If a master-receiver is involved in a transfer, it must signal the end of data to the slave-transmitter by not generating an ACK on the final byte that is clocked out of the slave. The slave-transmitter must release the data line to allow the master to generate a STOP or a repeated START condition.

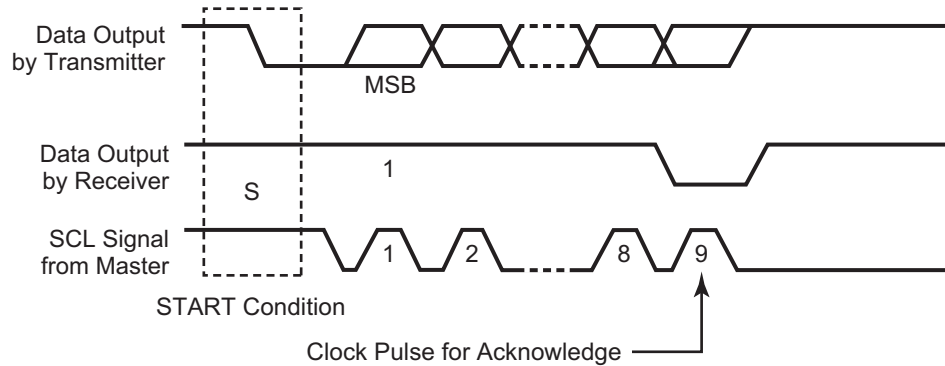

Figure 33. I²C Acknowledge

Clock Synchronization

All masters generate their own clocks on the SCL line to transfer messages on the I²C bus. Data is only valid during the High period of each clock.

Clock synchronization is performed using the wired AND connection of the I²C interfaces to the SCL line, meaning that a High-to-Low transition on the SCL line causes the relevant devices to start counting from their Low period. When a device clock goes Low, it holds the SCL line in that state until the clock High state is reached. See Figure 34. The Low-to-High transition of this clock, however, may not change the state of the SCL line if another clock is still within its Low period. The SCL line is held Low by the device with the longest Low period. Devices with shorter Low periods enter a High wait-state during this time.

When all devices concerned count off their Low period, the clock line is released and goes High. There is no difference between the device clocks and the state of the SCL line, and all of the devices start counting their High periods. The first device to complete its High period again pulls the SCL line Low. In this way, a synchronized SCL clock is generated with its Low period determined by the device with the longest clock Low period, and its High period determined by the one with the shortest clock High period.

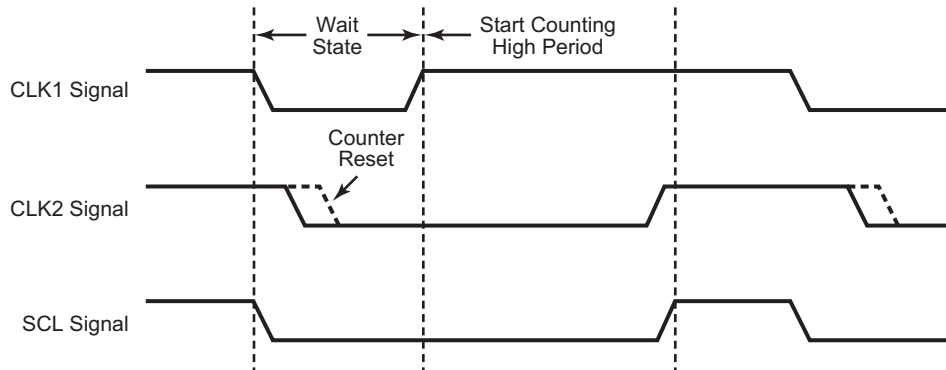

Figure 34. Clock Synchronization In I²C Protocol

Arbitration

A master may start a transfer only if the bus is free. Two or more masters may generate a START condition within the minimum hold time of the START condition which results in a defined START condition to the bus. Arbitration takes place on the SDA line, while the SCL line is at the High level, in such a way that the master which transmits a High level, while another master is transmitting a Low level switches off its data output stage because the level on the bus doesn't correspond to its own level.

Arbitration can continue for many bits. Its first stage is comparison of the address bits. If the masters are each trying to address the same device, arbitration continues with comparison of the data. Because address and data information on the I²C bus is used for arbitration, no information is lost during this process. A master which loses the arbitration can generate clock pulses until the end of the byte in which it loses the arbitration.

If a master also incorporates a slave function and it loses arbitration during the addressing stage, it's possible that the winning master is trying to address it. The losing master must switch over immediately to its slave-receiver mode. Figure 34 illustrates the arbitration procedure for two masters. Of course, more may be involved (depending on how many masters are connected to the bus). The moment there is a difference between the internal data level of the master generating DATA 1 and the actual level on the SDA line, its data output is switched off, which means that a High output level is then connected to the bus. As a result, the data transfer initiated by the winning master is not affected. Because control of the I²C bus is decided solely on the address and data sent by competing masters, there is no central master, nor any order of priority on the bus.

Special attention must be paid if, during a serial transfer, the arbitration procedure is still in progress at the moment when a repeated START condition or a STOP



condition is transmitted to the I²C bus. If it is possible for such a situation to occur, the masters involved must send this repeated START condition or STOP condition at the same position in the format frame. In other words, arbitration is not allowed between:

- A repeated START condition and a data bit
- A STOP condition and a data bit
- A repeated START condition and a STOP condition

Clock Synchronization for Handshake

The Clock synchronizing mechanism can function as a handshake, enabling receivers to cope with fast data transfers, on either a byte or bit level. The byte level allows a device to receive a byte of data at a fast rate, but allows the device more time to store the received byte or to prepare another byte for transmission. Slaves hold the SCL line Low after reception and acknowledge the byte, forcing the master into a wait state until the slave is ready for the next byte transfer in a handshake procedure.

Operating Modes

Master Transmit

In MASTER TRANSMIT mode, the I²C transmits a number of bytes to a slave receiver.

Enter MASTER TRANSMIT mode by setting the STA bit in the I2C_CTL register to 1. The I²C then tests the I²C bus and transmits a START condition when the bus is free. When a START condition is transmitted, the IFLG bit is 1 and the status code in the I2C_SR register is 08h. Before this interrupt is serviced, the I2C_DR register must be loaded with either a 7-bit slave address or the first part of a 10-bit slave address, with the lsb cleared to 0 to specify TRANSMIT mode. The IFLG bit should now be cleared to 0 to prompt the transfer to continue.

After the 7-bit slave address (or the first part of a 10-bit address) plus the Write bit are transmitted, the IFLG is set again. A number of status codes are possible in the I2C_SR register. See Table 75.

Table 75. I²C Master Transmit Status Codes

| Code | I ² C State | Microprocessor Response | Next I ² C Action |
|------|--|---|-------------------------------------|
| 18h | Addr+W transmitted ¹ , ACK received | For a 7-bit address: write byte to DATA, clear IFLG | Transmit data byte, receive ACK |
| | | Or set STA, clear IFLG | Transmit repeated START |
| | | Or set STP, clear IFLG | Transmit STOP |
| | | Or set STA & STP, clear IFLG | Transmit STOP then START |
| | | For a 10-bit address: write extended address byte to DATA, clear IFLG | Transmit extended address byte |
| 20h | Addr+W transmitted, ACK not received | Same as code 18h | Same as code 18h |
| 38h | Arbitration lost | Clear IFLG | Return to idle |
| | | Or set STA, clear IFLG | Transmit START when bus is free |
| 68h | Arbitration lost, +W received, ACK transmitted | Clear IFLG, AAK = 0 ² | Receive data byte, transmit NACK |
| | | Or clear IFLG, AAK = 1 | Receive data byte, transmit ACK |
| 78h | Arbitration lost, General call addr received, ACK transmitted | Same as code 68h | Same as code 68h |
| B0h | Arbitration lost, SLA+R received, ACK transmitted | Write byte to DATA, clear IFLG, clear AAK = 0 | Transmit last byte, receive ACK |
| | | Or write byte to DATA, clear IFLG, set AAK = 1 | Transmit data byte, receive ACK |

Notes:

1. W is defined as the write bit; i.e., the lsb is cleared to 0.
2. AAK is defined as the I²C Acknowledge bit.

If 10-bit addressing is being used, then the status code is 18h or 20h after the first part of a 10-bit address plus the Write bit are successfully transmitted.

After this interrupt is serviced and the second part of the 10-bit address is transmitted, the I2C_SR register contains one of the codes in Table 76.

Table 76. I²C 10-Bit Master Transmit Status Codes

| Code | I ² C State | Microprocessor Response | Next I ² C Action |
|------|---|---|-------------------------------------|
| 38h | Arbitration lost | Clear IFLG | Return to idle |
| | | Or set STA, clear IFLG | Transmit START when bus free |
| 68h | Arbitration lost, SLA+W received, ACK transmitted | Clear IFLG, clear AAK = 0 | Receive data byte, transmit NACK |
| | | Or clear IFLG, set AAK = 1 | Receive data byte, transmit ACK |
| B0h | Arbitration lost, SLA+R received, ACK transmitted | Write byte to DATA, clear IFLG, clear AAK = 0 | Transmit last byte, receive ACK |
| | | Or write byte to DATA, clear IFLG, set AAK = 1 | Transmit data byte, receive ACK |
| D0h | Second Address byte + W transmitted, ACK received | Write byte to DATA, clear IFLG | Transmit data byte, receive ACK |
| | | Or set STA, clear IFLG | Transmit repeated START |
| | | Or set STP, clear IFLG | Transmit STOP |
| | | Or set STA & STP, clear IFLG | Transmit STOP then START |
| D8h | Second Address byte + W transmitted, ACK not received | Same as code D0h | Same as code D0h |

If a repeated START condition is transmitted, the status code is 10h instead of 08h.

After each data byte is transmitted, the IFLG is 1 and one of the status codes listed in Table 77 is in the I2C_SR register.

Table 77. I²C Master Transmit Status Codes For Data Bytes

| Code | I ² C State | Microprocessor Response | Next I ² C Action |
|------|---|--------------------------------|---------------------------------|
| 28h | Data byte transmitted, ACK received | Write byte to DATA, clear IFLG | Transmit data byte, receive ACK |
| | | Or set STA, clear IFLG | Transmit repeated START |
| | | Or set STP, clear IFLG | Transmit STOP |
| | | Or set STA & STP, clear IFLG | Transmit START then STOP |
| 30h | Data byte transmitted, ACK not received | Same as code 28h | Same as code 28h |
| 38h | Arbitration lost | Clear IFLG | Return to idle |
| | | Or set STA, clear IFLG | Transmit START when bus free |

When all bytes are transmitted, the microprocessor should write a 1 to the STP bit in the I2C_CTL register. The I²C then transmits a STOP condition, clears the STP bit and returns to the idle state.

Master Receive

In MASTER RECEIVE mode, the I²C receives a number of bytes from a slave transmitter.

After the START condition is transmitted, the IFLG bit is 1 and the status code 08h is loaded in the I2C_SR register. The I2C_DR register should be loaded with the slave address (or the first part of a 10-bit slave address), with the lsb set to 1 to signify a READ. The IFLG bit should be cleared to 0 as a prompt for the transfer to continue.

When the 7-bit slave address (or the first part of a 10-bit address) and the Read bit are transmitted, the IFLG bit is set and one of the status codes listed in Table 78 is in the I2C_SR register.

Table 78. I²C Master Receive Status Codes

| Code | I ² C State | Microprocessor Response | Next I ² C Action |
|------|---|--|----------------------------------|
| 40h | Addr + R transmitted, ACK received | For a 7-bit address, clear IFLG, AAK = 0 | Receive data byte, transmit NACK |
| | | Or clear IFLG, AAK = 1 | Receive data byte, transmit ACK |
| | | For a 10-bit address Write extended address byte to DATA, clear IFLG | Transmit extended address byte |
| 48h | Addr + R transmitted, ACK not received | For a 7-bit address: Set STA, clear IFLG | Transmit repeated START |
| | | Or set STP, clear IFLG | Transmit STOP |
| | | Or set STA & STP, clear IFLG | Transmit STOP then START |
| | | For a 10-bit address: Write extended address byte to DATA, clear IFLG | Transmit extended address byte |
| 38h | Arbitration lost | Clear IFLG | Return to idle |
| | | Or set STA, clear IFLG | Transmit START when bus is free |
| 68h | Arbitration lost, SLA+W received, ACK transmitted | Clear IFLG, clear AAK = 0 | Receive data byte, transmit NACK |
| | | Or clear IFLG, set AAK = 1 | Receive data byte, transmit ACK |
| 78h | Arbitration lost, General call addr received, ACK transmitted | Same as code 68h | Same as code 68h |
| B0h | Arbitration lost, SLA+R received, ACK transmitted | Write byte to DATA, clear IFLG, clear AAK = 0 | Transmit last byte, receive ACK |
| | | Or write byte to DATA, clear IFLG, set AAK = 1 | Transmit data byte, receive ACK |

R = Read bit; that is, the lsb is set to 1.

If 10-bit addressing is being used, the slave is first addressed using the full 10-bit address plus the Write bit. The master then issues a restart followed by the first part of the 10-bit address again, but with the Read bit. The status code then



becomes 40h or 48h. It is the responsibility of the slave to remember that it had been selected prior to the restart.

If a repeated START condition is received, the status code is 10h instead of 08h.

After each data byte is received, the IFLG is set and one of the status codes listed in Table 79 is in the I2C_SR register.

Table 79. I²C Master Receive Status Codes For Data Bytes

| Code | I ² C State | Microprocessor Response | Next I ² C Action |
|------|--------------------------------------|---|----------------------------------|
| 50h | Data byte received, ACK transmitted | Read DATA, clear IFLG, clear AAK = 0 | Receive data byte, transmit NACK |
| | | Or read DATA, clear IFLG, set AAK = 1 | Receive data byte, transmit ACK |
| 58h | Data byte received, NACK transmitted | Read DATA, set STA, clear IFLG | Transmit repeated START |
| | | Or read DATA, set STP, clear IFLG | Transmit STOP |
| | | Or read DATA, set STA & STP, clear IFLG | Transmit STOP then START |
| 38h | Arbitration lost in NACK bit | Same as master transmit | Same as master transmit |

When all bytes are received, a NACK should be sent, then the microprocessor should write a 1 to the STP bit in the I2C_CTL register. The I²C then transmits a STOP condition, clears the STP bit and returns to the idle state.

Slave Transmit

In SLAVE TRANSMIT mode, a number of bytes are transmitted to a master receiver.

The I²C enters SLAVE TRANSMIT mode when it receives its own slave address and a Read bit after a START condition. The I²C then transmits an acknowledge bit (if the AAK bit is set to 1) and sets the IFLG bit in the I2C_CTL register and the I2C_SR register contains the status code A8h.

- **Note:** When I²C contains a 10-bit slave address (signified by F0h–F7h in the I2C_SAR register), it transmits an acknowledge after the first address byte is received after a restart. An interrupt is generated, IFLG is set but the status does not change. No second address byte is sent by the master. It is up to the slave to remember it had been selected prior to the restart.



I²C goes from MASTER mode to SLAVE TRANSMIT mode when arbitration is lost during the transmission of an address, and the slave address and Read bit are received. This action is represented by the status code B0h in the I2C_SR register.

The data byte to be transmitted is loaded into the I2C_DR register and the IFLG bit cleared. After the I²C transmits the byte and receives an acknowledge, the IFLG bit is set and the I2C_SR register contains B8h. When the final byte to be transmitted is loaded into the I2C_DR register, the AAK bit is cleared when the IFLG is cleared. After the final byte is transmitted, the IFLG is set and the I2C_SR register contains C8h and the I²C returns to the idle state. The AAK bit must be set to 1 before reentering SLAVE mode.

If no acknowledge is received after transmitting a byte, the IFLG is set and the I2C_SR register contains C0h. The I²C then returns to the idle state.

If a STOP condition is detected after an acknowledge bit, the I²C returns to the idle state.

Slave Receive

In SLAVE RECEIVE mode, a number of data bytes are received from a master transmitter.

The I²C enters SLAVE RECEIVE mode when it receives its own slave address and a Write bit (Isb = 0) after a START condition. The I²C transmits an acknowledge bit and sets the IFLG bit in the I2C_CTL register and the I2C_SR register contains the status code 60h. The I²C also enters SLAVE RECEIVE mode when it receives the general call address 00h (if the GCE bit in the I2C_SAR register is set). The status code is then 70h.

- **Note:** When the I²C contains a 10-bit slave address (signified by F0h–F7h in the I2C_SAR register), it transmits an acknowledge after the first address byte is received but no interrupt is generated. IFLG is not set and the status does not change. The I²C generates an interrupt only after the second address byte is received. The I²C sets the IFLG bit and loads the status code as described above.

I²C goes from MASTER mode to SLAVE RECEIVE mode when arbitration is lost during the transmission of an address, and the slave address and Write bit (or the general call address if the CGE bit in the I2C_SAR register is set to 1) are received. The status code in the I2C_SR register is 68h if the slave address is received or 78h if the general call address is received. The IFLG bit must be cleared to 0 to allow data transfer to continue.

If the AAK bit in the I2C_CTL register is set to 1 then an acknowledge bit (Low level on SDA) is transmitted and the IFLG bit is set after each byte is received. The I2C_SR register contains the status code 80h or 90h if SLAVE RECEIVE



mode is entered with the general call address. The received data byte can be read from the I2C_DR register and the IFLG bit must be cleared to allow the transfer to continue. If a STOP condition or a repeated START condition is detected after the acknowledge bit, the IFLG bit is set and the I2C_SR register contains status code A0h.

If the AAK bit is cleared to 0 during a transfer, the I²C transmits a not-acknowledge bit (High level on SDA) after the next byte is received, and set the IFLG bit. The I2C_SR register contains the status code 88h or 98h if SLAVE RECEIVE mode is entered with the general call address. The I²C returns to the idle state when the IFLG bit is cleared to 0.

I²C Registers

Addressing

The processor interface provides access to six 8-bit registers: four Read/Write registers, one Read-Only register and two Write-Only registers, as indicated in Table 80.

Table 80. I²C Register Descriptions

| Register | Description |
|----------|--------------------------------------|
| I2C_SAR | Slave address register |
| I2C_XSAR | Extended slave address register |
| I2C_DR | Data byte register |
| I2C_CTL | Control register |
| I2C_SR | Status register (Read-Only) |
| I2C_CCR | Clock Control register (Write-Only) |
| I2C_SRR | Software reset register (Write-Only) |

Resetting the I²C Registers

Hardware reset. When the I²C is reset by a hardware reset of the eZ80L92, the I2C_SAR, I2C_XSAR, I2C_DR and I2C_CTL registers are cleared to 00h; while the I2C_SR register is set to F8h.

Software Reset. Perform a software reset by writing any value to the I²C Software Reset Register (I2C_SRR). A software reset sets the I²C back to idle and the STP, STA, and IFLG bits of the I2C_CTL register to 0.



I²C Slave Address Register

The I2C_SAR register provides the 7-bit address of the I²C when in SLAVE mode and allows 10-bit addressing in conjunction with the I2C_XSAR register. I2C_SAR[7:1] = sla[6:0] is the 7-bit address of the I²C when in 7-bit SLAVE mode. When the I²C receives this address after a START condition, it enters SLAVE mode. I2C_SAR[7] corresponds to the first bit received from the I²C bus.

When the register receives an address starting with F7h to F0h (I2C_SAR[7:3] = 11110b), the I²C recognizes that a 10-bit slave addressing mode is being selected. The I²C sends an ACK after receiving the I2C_SAR byte (the device does not generate an interrupt at this point). After the next byte of the address (I2C_XSAR) is received, the I²C generates an interrupt and goes into SLAVE mode. Then I2C_SAR[2:1] are used as the upper 2 bits for the 10-bit extended address. The full 10-bit address is supplied by {I2C_SAR[2:1], I2C_XSAR[7:0]}. See Table 81.

Table 81. I²C Slave Address Register (I2C_SAR = 00C8h)

| Bit | 7 | 6 | 5 | 4 | 3 | 2 | 1 | 0 |
|------------|-----|-----|-----|-----|-----|-----|-----|-----|
| Reset | 0 | 0 | 0 | 0 | 0 | 0 | 0 | 0 |
| CPU Access | R/W | R/W | R/W | R/W | R/W | R/W | R/W | R/W |

Note: R/W = Read/Write.

| Bit Position | Value | Description |
|--------------|-------------|--|
| [7:1] SLA | 00h– 7Fh | 7-bit slave address or upper 2 bits, I2C_SAR[2:1], of address when operating in 10-bit mode. |
| 0 GCE | 0 | I ² C not enabled to recognize the General Call Address. |
| | 1 | I ² C enabled to recognize the General Call Address. |

I²C Extended Slave Address Register

The I2C_XSAR register is used in conjunction with the I2C_SAR register to provide 10-bit addressing of the I²C when in SLAVE mode. The I2C_SAR value forms the lower 8 bits of the 10-bit slave address. The full 10-bit address is supplied by {I2C_SAR[2:1], I2C_XSAR[7:0]}.

When the register receives an address starting with F7h to F0h (I2C_SAR[7:3] = 11110b), the I²C recognizes that a 10-bit slave addressing mode is being selected. The I²C sends an ACK after receiving the I2C_XSAR byte (the device does not generate an interrupt at this point). After the next byte of the address (I2C_XSAR) is received, the I²C generates an interrupt and goes into SLAVE mode. Then I2C_SAR[2:1] are used as the upper 2 bits for the 10-bit extended



address. The full 10-bit address is supplied by {I2C_SAR[2:1], I2C_XSAR[7:0]}. See Table 82.

Table 82. I²C Extended Slave Address Register (I2C_XSAR = 00C9h)

| | | | | | | | | |
|------------|-----|-----|-----|-----|-----|-----|-----|-----|
| Bit | 7 | 6 | 5 | 4 | 3 | 2 | 1 | 0 |
| Reset | 0 | 0 | 0 | 0 | 0 | 0 | 0 | 0 |
| CPU Access | R/W | R/W | R/W | R/W | R/W | R/W | R/W | R/W |

Note: R/W = Read/Write.

| Bit Position | Value | Description |
|---------------|-------------|--|
| [7:0] SLAX | 00h– FFh | Least significant 8 bits of the 10-bit extended slave address. |

I²C Data Register

This register contains the data byte/slave address to be transmitted or the data byte just received. In transmit mode, the most significant bit of the byte is transmitted first. In receive mode, the first bit received is placed in the most significant bit of the register. After each byte is transmitted, the I2C_DR register contains the byte that is present on the bus in case a lost arbitration event occurs. See Table 83.

Table 83. I²C Data Register (I2C_DR = 00CAh)

| | | | | | | | | |
|------------|-----|-----|-----|-----|-----|-----|-----|-----|
| Bit | 7 | 6 | 5 | 4 | 3 | 2 | 1 | 0 |
| Reset | 0 | 0 | 0 | 0 | 0 | 0 | 0 | 0 |
| CPU Access | R/W | R/W | R/W | R/W | R/W | R/W | R/W | R/W |

Note: R/W = Read/Write.

| Bit Position | Value | Description |
|---------------|-------------|-----------------------------|
| [7:0] DATA | 00h– FFh | I ² C data byte. |

I²C Control Register

The I2C_CTL register is a control register that is used to control the interrupts and the master slave relationships on the I²C bus.



When the Interrupt Enable bit (IEN) is set to 1, the interrupt line goes High when the IFLG is set to 1. When IEN is cleared to 0, the interrupt line always remains Low.

When the Bus Enable bit (ENAB) is set to 0, the I²C bus inputs SCLx and SDAX are ignored and the I²C module does not respond to any address on the bus. When ENAB is set to 1, the I²C responds to calls to its slave address and to the general call address if the GCE bit (I2C_SAR[0]) is set to 1.

When the Master Mode Start bit (STA) is set to 1, the I²C enters MASTER mode and sends a START condition on the bus when the bus is free. If the STA bit is set to 1 when the I²C module is already in MASTER mode and one or more bytes are transmitted, then a repeated START condition is sent. If the STA bit is set to 1 when the I²C block is being accessed in SLAVE mode, the I²C completes the data transfer in SLAVE mode and then enters MASTER mode when the bus is released. The STA bit is automatically cleared after a START condition is set. Writing a 0 to this bit produces no effect.

If the Master Mode Stop bit (STP) is set to 1 in MASTER mode, a STOP condition is transmitted on the I²C bus. If the STP bit is set to 1 in slave mode, the I²C module operates as if a STOP condition is received, but no STOP condition is transmitted. If both STA and STP bits are set, the I²C block first transmits the STOP condition (if in MASTER mode) and then transmit the START condition. The STP bit is cleared automatically. Writing a 0 to this bit produces no effect.

The I²C Interrupt Flag (IFLG) is set to 1 automatically when any of 30 of the possible 31 I²C states is entered. The only state that does not set the IFLG bit is state F8h. If IFLG is set to 1 and the IEN bit is also set, an interrupt is generated. When IFLG is set by the I²C, the Low period of the I²C bus clock line is stretched and the data transfer is suspended. When a 0 is written to IFLG, the interrupt is cleared and the I²C clock line is released.

When the I²C Acknowledge bit (AAK) is set to 1, an Acknowledge is sent during the acknowledge clock pulse on the I²C bus if:

- Either the whole of a 7-bit slave address or the first or second byte of a 10-bit slave address is received
- The general call address is received and the General Call Enable bit in I2C_SAR is set to 1
- A data byte is received while in MASTER or SLAVE modes

When AAK is cleared to 0, a NACK is sent when a data byte is received in MASTER or SLAVE mode. If AAK is cleared to 0 in the Slave Transmitter mode, the byte in the I2C_DR register is assumed to be the final byte. After this byte is transmitted, the I²C block enter states C8h, then returns to the idle state. The I²C module does not respond to its slave address unless AAK is set. See Table 84.

Table 84. I²C Control Registers (I2C_CTL = 00CBh)

| | | | | | | | | |
|------------|-----|-----|-----|-----|-----|-----|---|---|
| Bit | 7 | 6 | 5 | 4 | 3 | 2 | 1 | 0 |
| Reset | 0 | 0 | 0 | 0 | 0 | 0 | 0 | 0 |
| CPU Access | R/W | R/W | R/W | R/W | R/W | R/W | R | R |

Note: R/W = Read/Write; R = Read Only.

| Bit Position | Value | Description |
|--------------|-------|--|
| 7 IEN | 0 | I ² C interrupt is disabled. |
| | 1 | I ² C interrupt is enabled. |
| 6 ENAB | 0 | The I ² C bus (SCL/SDA) is disabled and all inputs are ignored. |
| | 1 | The I ² C bus (SCL/SDA) is enabled. |
| 5 STA | 0 | Master mode START condition is sent. |
| | 1 | Master mode start-transmit START condition on the bus. |
| 4 STP | 0 | Master mode STOP condition is sent. |
| | 1 | Master mode stop-transmit STOP condition on the bus. |
| 3 IFLG | 0 | I ² C interrupt flag is not set. |
| | 1 | I ² C interrupt flag is set. |
| 2 AAK | 0 | Not Acknowledge. |
| | 1 | Acknowledge. |
| [1:0] | 00 | Reserved. |



I²C Status Register

The I2C_SR register is a Read-Only register that contains a 5-bit status code in the five most significant bits: the three least significant bits are always 0. The Read-Only I2C_SR registers share the same I/O addresses as the Write-Only I2C_CCR registers. See Table 85.

Table 85. I²C Status Registers (I2C_SR = 00CCh)

| | | | | | | | | |
|------------|---|---|---|---|---|---|---|---|
| Bit | 7 | 6 | 5 | 4 | 3 | 2 | 1 | 0 |
| Reset | 1 | 1 | 1 | 1 | 1 | 0 | 0 | 0 |
| CPU Access | R | R | R | R | R | R | R | R |

Note: R = Read only.

| Bit Position | Value | Description |
|---------------|-----------------|-------------------------------------|
| [7:3] STAT | 00000– 11111 | 5-bit I ² C status code. |
| [2:0] | 000 | Reserved. |

There are 29 possible status codes, as listed in Table 86. When the I2C_SR register contains the status code F8h, no relevant status information is available, no interrupt is generated and the IFLG bit in the I2C_CTL register is not set. All other status codes correspond to a defined state of the I²C.

When each of these states is entered, the corresponding status code appears in this register and the IFLG bit in the I2C_CTL register is set. When the IFLG bit is cleared, the status code returns to F8h.

Table 86. I²C Status Codes

| Code | Status |
|------|--|
| 00h | Bus error |
| 08h | START condition transmitted |
| 10h | Repeated START condition transmitted |
| 18h | Address and Write bit transmitted, ACK received |
| 20h | Address and Write bit transmitted, ACK not received |
| 28h | Data byte transmitted in MASTER mode, ACK received |
| 30h | Data byte transmitted in MASTER mode, ACK not received |
| 38h | Arbitration lost in address or data byte |

Table 86. I²C Status Codes (Continued)

| Code | Status |
|------|--|
| 40h | Address and Read bit transmitted, ACK received |
| 48h | Address and Read bit transmitted, ACK not received |
| 50h | Data byte received in MASTER mode, ACK transmitted |
| 58h | Data byte received in MASTER mode, NACK transmitted |
| 60h | Slave address and Write bit received, ACK transmitted |
| 68h | Arbitration lost in address as master, slave address and Write bit received, ACK transmitted |
| 70h | General Call address received, ACK transmitted |
| 78h | Arbitration lost in address as master, General Call address received, ACK transmitted |
| 80h | Data byte received after slave address received, ACK transmitted |
| 88h | Data byte received after slave address received, NACK transmitted |
| 90h | Data byte received after General Call received, ACK transmitted |
| 98h | Data byte received after General Call received, NACK transmitted |
| A0h | STOP or repeated START condition received in SLAVE mode |
| A8h | Slave address and Read bit received, ACK transmitted |
| B0h | Arbitration lost in address as master, slave address and Read bit received, ACK transmitted |
| B8h | Data byte transmitted in SLAVE mode, ACK received |
| C0h | Data byte transmitted in SLAVE mode, ACK not received |
| C8h | Last byte transmitted in SLAVE mode, ACK received |
| D0h | Second Address byte and Write bit transmitted, ACK received |
| D8h | Second Address byte and Write bit transmitted, ACK not received |
| F8h | No relevant status information, IFLG = 0 |

If an illegal condition occurs on the I²C bus, the bus error state is entered (status code 00h). To recover from this state, the STP bit in the I2C_CTL register must be set and the IFLG bit cleared. The I²C then returns to the idle state. No STOP condition is transmitted on the I²C bus.

- **Note:** The STP and STA bits may be set to 1 at the same time to recover from the bus error. The I²C then sends a START.



I²C Clock Control Register

The I2C_CCR register is a Write-Only register. The seven LSBs control the frequency at which the I²C bus is sampled and the frequency of the I²C clock line (SCL) when the I²C is in MASTER mode. The Write-Only I2C_CCR registers share the same I/O addresses as the Read-Only I2C_SR registers. See Table 87.

Table 87. I²C Clock Control Registers (I2C_CCR = 00CCh)

| | | | | | | | | |
|------------|---|---|---|---|---|---|---|---|
| Bit | 7 | 6 | 5 | 4 | 3 | 2 | 1 | 0 |
| Reset | 0 | 0 | 0 | 0 | 0 | 0 | 0 | 0 |
| CPU Access | W | W | W | W | W | W | W | W |

Note: W = Read only.

| Bit Position | Value | Description |
|--------------|---------------|--|
| 7 | 0 | Reserved. |
| [6:3] M | 0000– 1111 | I ² C clock divider scalar value. |
| [2:0] N | 000– 111 | I ² C clock divider exponent. |

The I²C clocks are derived from the eZ80L92's system clock. The frequency of the eZ80L92 system clock is f_{SCLK} . The I²C bus is sampled by the I²C block at the frequency f_{SAMP} supplied by:

$$f_{SAMP} = \frac{f_{SCLK}}{2^N}$$

In MASTER mode, the I²C clock output frequency on SCL (f_{SCL}) is supplied by:

$$f_{SCL} = \frac{f_{SCLK}}{10 \cdot (M + 1)(2)^N}$$

The use of two separately-programmable dividers allows the MASTER mode output frequency to be set independently of the frequency at which the I²C bus is sampled. This feature is particularly useful in multimaster systems because the frequency at which the I²C bus is sampled must be at least 10 times the frequency of the fastest master on the bus to ensure that START and STOP conditions are always detected. By using two programmable clock divider stages, a high sam-



pling frequency can be ensured while allowing the MASTER mode output to be set to a lower frequency.

Bus Clock Speed

The I²C bus is defined for bus clock speeds up to 100 KBPS (400 KBPS in FAST mode).

To ensure correct detection of START and STOP conditions on the bus, the I²C must sample the I²C bus at least ten times faster than the bus clock speed of the fastest master on the bus. The sampling frequency should therefore be at least 1 MHz (4 MHz in FAST mode) to guarantee correct operation with other bus masters.

The I²C sampling frequency is determined by the frequency of the eZ80L92 system clock and the value in the I2C_CCR bits 2 to 0. The bus clock speed generated by the I²C in MASTER mode is determined by the frequency of the input clock and the values in I2C_CCR[2:0] and I2C_CCR[6:3].

I²C Software Reset Register

The I2C_SRR register is a Write-Only register. Writing any value to this register performs a software reset of the I²C module. See Table 88.

Table 88. I²C Software Reset Register (I2C_SRR = 00CDh)

| | | | | | | | | |
|------------|---|---|---|---|---|---|---|---|
| Bit | 7 | 6 | 5 | 4 | 3 | 2 | 1 | 0 |
| Reset | X | X | X | X | X | X | X | X |
| CPU Access | W | W | W | W | W | W | W | W |

Note: W = Write-Only.

| Bit Position | Value | Description |
|--------------|-------------|--|
| [7:0] SRR | 00h– FFh | Writing any value to this register performs a software reset of the I ² C module. |

ZiLOG Debug Interface

Introduction

The ZiLOG Debug Interface (ZDI) provides a built-in debugging interface to the eZ80[®] CPU. ZDI provides basic in-circuit emulation features including:

- Examining and modifying internal registers
- Examining and modifying memory
- Starting and stopping the user program
- Setting program and data BREAK points
- Single-stepping the user program
- Executing user-supplied instructions
- Debugging the final product with the inclusion of one small connector
- Downloading code into SRAM
- C source-level debugging using ZiLOG Developer Studio (ZDS)

The above features are built into the silicon. Control is provided via a two-wire interface that is connected to the ZPAK emulator. Figure 35 illustrates a typical setup using a target board, ZPAK, and the host PC running ZiLOG Developer Studio. Refer to the [ZiLOG website](#) for more information on ZPAK and ZDS.

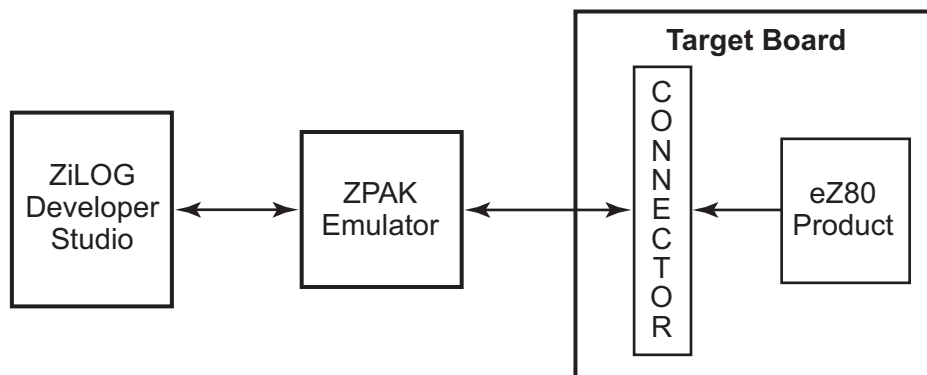

Figure 35. Typical ZDI Debug Setup

ZDI allows reading and writing of most internal registers without disturbing the state of the machine. READs and WriteS to memory may occur as fast as the ZDI

can download and upload data, with a maximum frequency of one-half the eZ80L92 system clock frequency. Table 89 lists the recommended frequencies of the ZDI clock in relation to the system clock.

Table 89. Recommended ZDI Clock vs. System Clock Frequency

| System Clock Frequency | ZDI Clock Frequency |
|------------------------|---------------------|
| 3–10Mhz | 1Mhz |
| 8–16Mhz | 2Mhz |
| 12–24 Mhz | 4Mhz |
| 20–50Mhz | 8Mhz |

ZDI-Supported Protocol

ZDI supports a bidirectional serial protocol. The protocol defines any device that sends data as the *transmitter* and any receiving device as the *receiver*. The device controlling the transfer is the *master* and the device being controlled is the *slave*. The master always initiates the data transfers and provides the clock for both receive and transmit operations. The ZDI block on the eZ80L92 is considered a slave in all data transfers.

Figure 36 illustrates the schematic for building a connector on a target board. This connector allows the user to connect directly to the ZPAK emulator using a six-pin header.

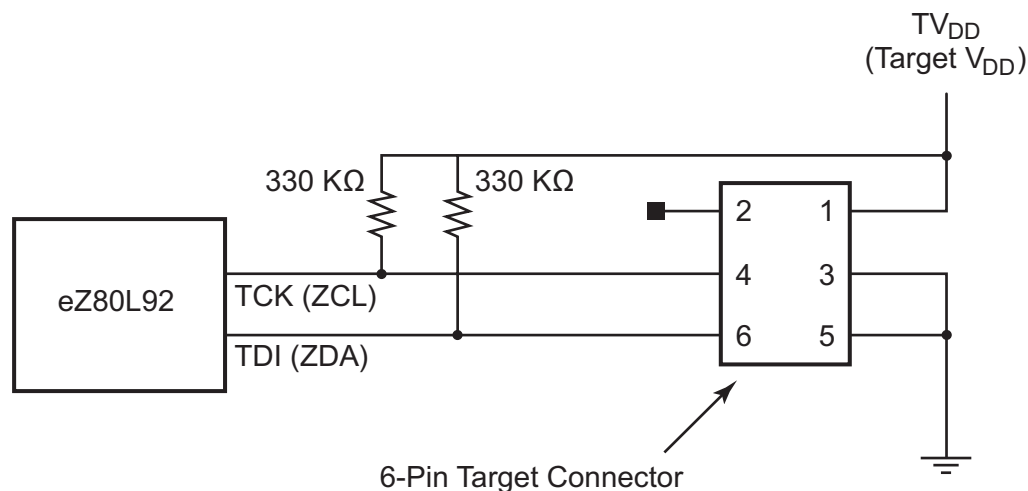

Figure 36. Schematic For Building a Target Board ZPAK Connector



ZDI Clock and Data Conventions

The two pins used for communication with the ZDI block are the ZDI Clock pin (ZCL) and the ZDI Data pin (ZDA). On the eZ80L92, the ZCL pin is shared with the TCK pin while the ZDA pin is shared with the TDI pin. The ZCL and ZDA pin functions are only available when the On-Chip Instrumentation is disabled and the ZDI is therefore enabled. For general data communication, the data value on the ZDA pin can change only when ZCL is Low (0). The only exception is the ZDI START bit, which is indicated by a High-to-Low transition (falling edge) on the ZDA pin while ZCL is High.

Data is shifted into and out of ZDI, with the most significant bit (bit 7) of each byte being first in time, and the least significant bit (bit 0) last in time. All information is passed between the master and the slave in 8-bit (single-byte) units. Each byte is transferred with nine clock cycles: eight to shift the data, and the ninth for internal operations.

ZDI START Condition

All ZDI commands are preceded by the ZDI START signal, which is a High-to-Low transition of ZDA when ZCL is High. The ZDI slave on the eZ80L92 continually monitors the ZDA and ZCL lines for the START signal and does not respond to any command until this condition is met. The master pulls ZDA Low, with ZCL High, to indicate the beginning of a data transfer with the ZDI block. Figures 37 and 38 illustrate a valid ZDI START signal prior to writing and reading data, respectively. A Low-to-High transition of ZDA while the ZCL is High produces no effect.

Data is shifted in during a Write to the ZDI block on the rising edge of ZCL, as illustrated in Figure 37. Data is shifted out during a Read from the ZDI block on the falling edge of ZCL as illustrated in Figure 38. When an operation is completed, the master stops during the ninth cycle and holds the ZCL signal High.

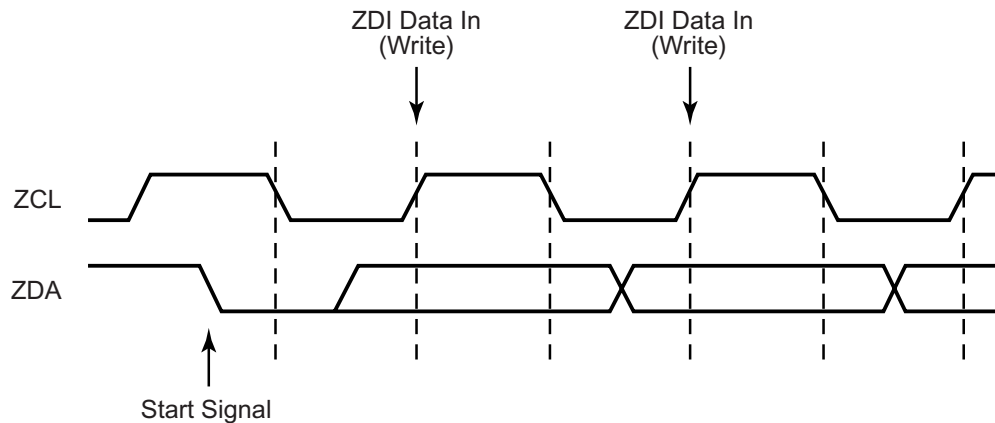

Figure 37. ZDI Write Timing

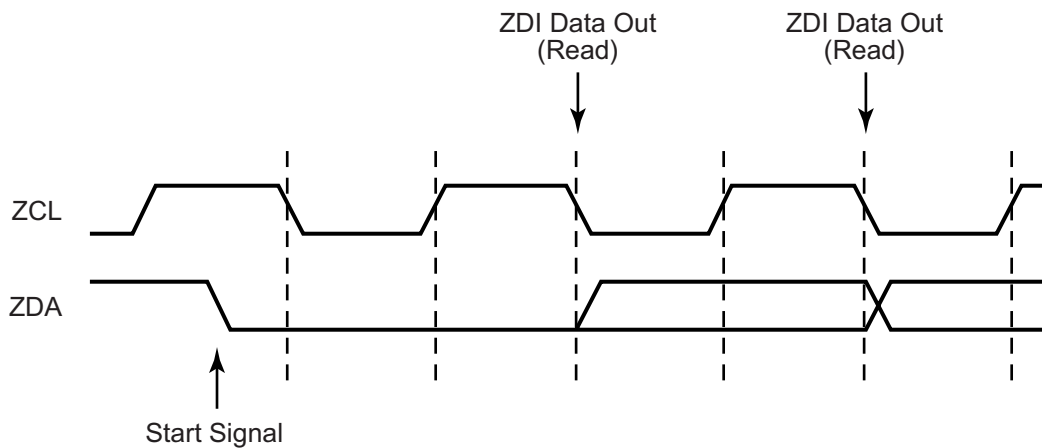

Figure 38. ZDI Read Timing

ZDI Single-Bit Byte Separator

Following each 8-bit ZDI data transfer, a single-bit byte separator is used. To initiate a new ZDI command, the single-bit byte separator must be High (logical 1) to allow for a new ZDI START command to be sent. For all other cases, the single-bit byte separator can be either Low (logical 0) or High (logical 1). When ZDI is configured to allow the CPU to accept external bus requests, the single-bit byte separator should be Low (logical 0) during all ZDI commands. This Low value indicates that ZDI is still operating and is not ready to relinquish the Bus. The CPU does not accept the external bus requests until the single-bit byte separator is a High (logi-

cal 1). For more information on accepting bus requests in ZDI DEBUG mode, please see the [Bus Requests During ZDI Debug Mode](#) section on page 163.

ZDI Register Addressing

Following a START signal the ZDI master must output the ZDI register address. All data transfers with the ZDI block use special ZDI registers. The ZDI control registers that reside in the ZDI register address space should not be confused with the eZ80L92 peripheral registers that reside in the I/O address space.

Many locations in the ZDI control register address space are shared by two registers, one for Read-Only access and one for Write-Only access. As an example, a Read from ZDI register address 00h returns the eZ80[®] Product ID Low Byte while a Write to this same location, 00h, stores the Low byte of one of the address match values used for generating BREAK points.

The format for a ZDI address is seven bits of address, followed by one bit for Read or WRITE control, and completed by a single-bit byte separator. The ZDI executes a Read or WRITE operation depending on the state of the R/W bit (0 = Write, 1 = Read). If no new START command is issued at completion of the Read or Write operation, the operation can be repeated. This allows repeated Read or WRITE operations without having to resend the ZDI command. A START signal must follow to initiate a new ZDI command. Figure 39 illustrates the timing for address Writes to ZDI registers.

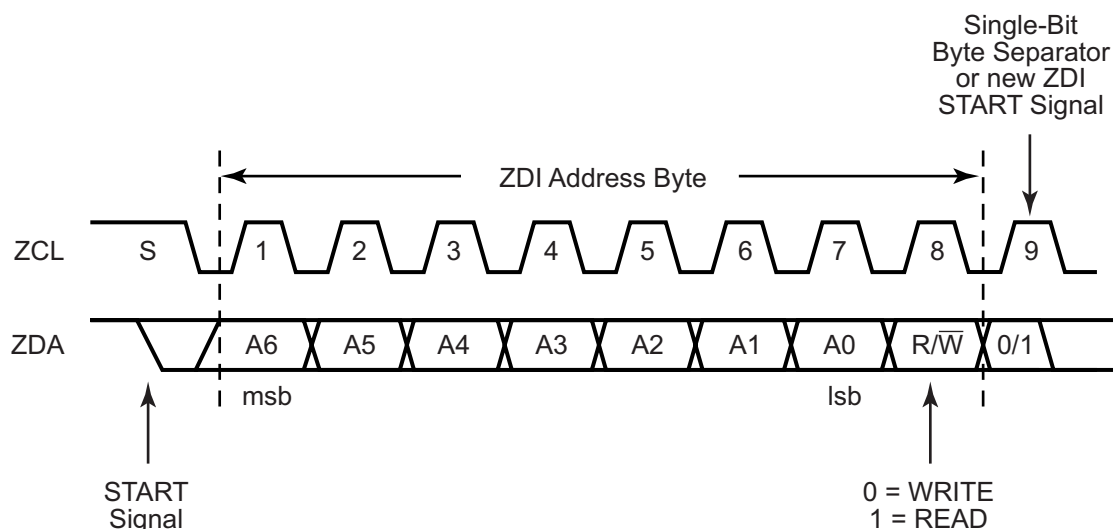

Figure 39. ZDI Address Write Timing

ZDI Write Operations

ZDI SINGLE-BYTE Write

For SINGLE-BYTE Write operations, the address and write control bit are first written to the ZDI block. Following the single-bit byte separator, the data is shifted into the ZDI block on the next 8 rising edges of ZCL. The master terminates activity after 8 clock cycles. Figure 40 illustrates the timing for ZDI SINGLE-BYTE WRITE operations.

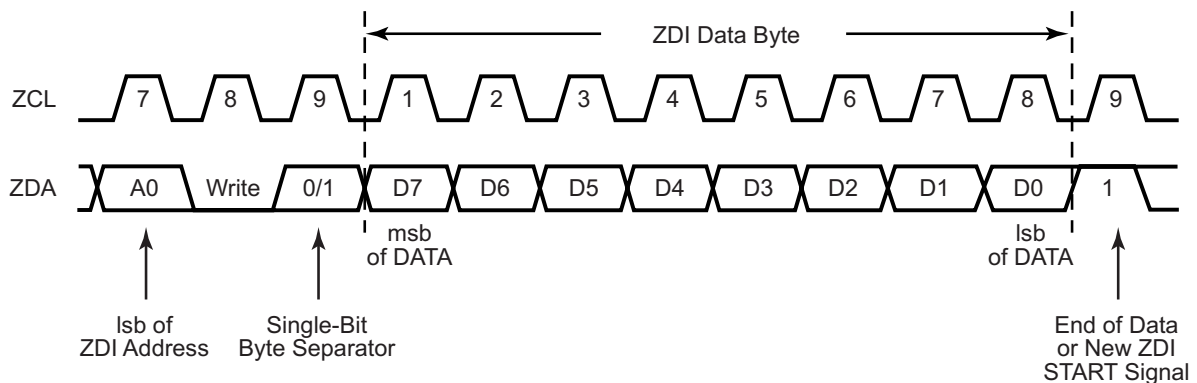

Figure 40. ZDI Single-Byte Data Write Timing

ZDI BLOCK Write

The BLOCK WRITE operation is initiated in the same manner as the SINGLE-BYTE Write operation, but instead of terminating the Write operation after the first data byte is transferred, the ZDI master can continue to transmit additional bytes of data to the ZDI slave on the eZ80L92. After the receipt of each byte of data the ZDI register address increments by 1. If the ZDI register address reaches the end of the Write-Only ZDI register address space (30h), the address stops incrementing. Figure 41 illustrates the timing for ZDI BLOCK WRITE operations.

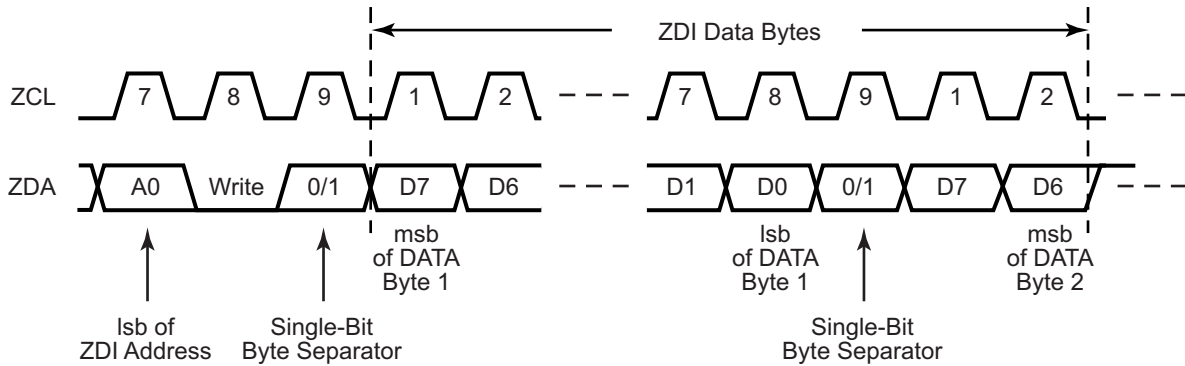

Figure 41. ZDI Block Data Write Timing

ZDI Read Operations

ZDI SINGLE-BYTE READ

SINGLE-BYTE Read operations are initiated in the same manner as SINGLE-BYTE Write operations, with the exception that the R/W bit of the ZDI register address is set to 1. Upon receipt of a slave address with the R/W bit set to 1, the eZ80L92's ZDI block loads the selected data into the shifter at the beginning of the first cycle following the single-bit data separator. The most significant bit (msb) is shifted out first. Figure 42 illustrates the timing for ZDI SINGLE-BYTE Read operations.

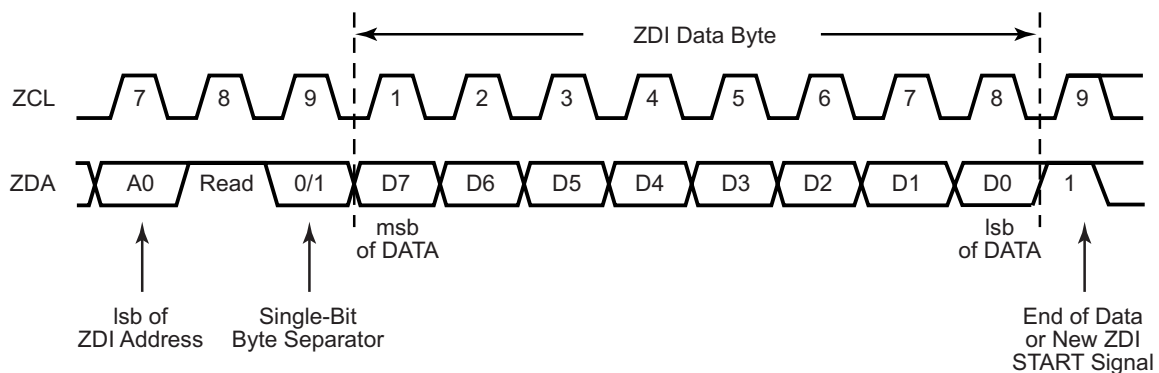

Figure 42. ZDI Single-Byte Data Read Timing

ZDI BLOCK READ

A BLOCK READ operation is initiated the same as a SINGLE-BYTE Read; however, the ZDI master continues to clock in the next byte from the ZDI slave as the ZDI slave continues to output data. The ZDI register address counter increments with each Read. If the ZDI register address reaches the end of the Read-Only ZDI register address space (20h), the address stops incrementing. Figure 43 illustrates the ZDI's BLOCK READ timing.

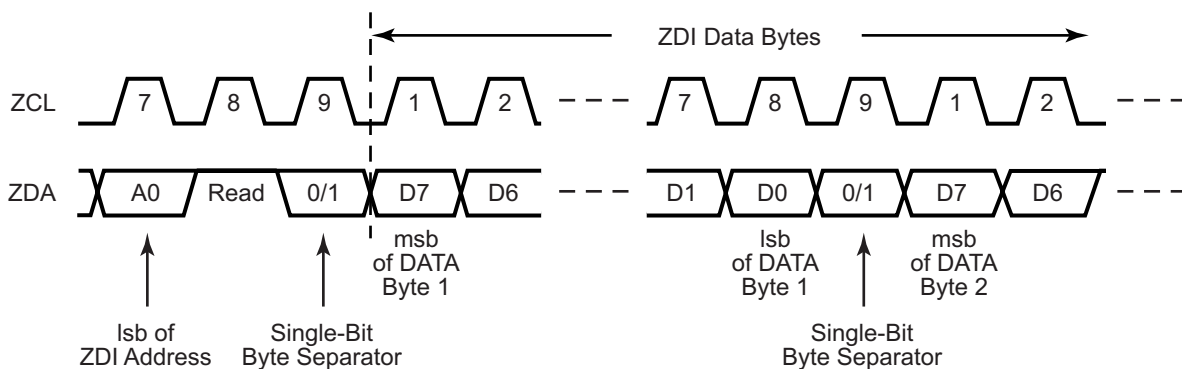

Figure 43. ZDI Block Data Read Timing

Operation of the eZ80L92 during ZDI BREAKpoints

If the ZDI forces the CPU to BREAK, only the CPU suspends operation. The system clock continues to operate and drive other peripherals. Those peripherals that can operate autonomously from the CPU may continue to operate, if so enabled. For example, the Watch-Dog Timer and Programmable Reload Timers continue to count during a ZDI BREAK point.

When using the ZDI interface, any Write or Read operations of peripheral registers in the I/O address space produces the same effect as Read or Write operations using the CPU. Because many register Read/Write operations exhibit secondary effects, such as clearing flags or causing operations to commence, the effects of the Read/Write operations during a ZDI BREAK must be taken into consideration.

Bus Requests During ZDI Debug Mode

The ZDI block on the eZ80L92 allows an external device to take control of the address and data bus while the eZ80L92 is in DEBUG mode. ZDI_BUSACK_EN causes ZDI to allow or prevent acknowledgement of bus requests by external peripherals. The bus acknowledge only occurs at the end of the current ZDI operation (indicated by a High during the single-bit byte separator). The default reset



condition is for bus acknowledgement to be disabled. To allow bus acknowledgement, the ZDI_BUSACK_EN must be written.

When an external bus request (BUSREQ pin asserted) is detected, ZDI waits until completion of the current operation before responding. ZDI acknowledges the bus request by asserting the bus acknowledge (BUSACK) signal. If the ZDI block is not currently shifting data, it acknowledges the bus request immediately. ZDI uses the single-bit byte separator of each data word to determine if it is at the end of a ZDI operation. If the bit is a logical 0, ZDI does not assert BUSACK to allow additional data Read or Write operations. If the bit is a logical 1, indicating completion of the ZDI commands, BUSACK is asserted.

Potential Hazards of Enabling Bus Requests During Debug Mode

There are some potential hazards that the user must be aware of when enabling external bus requests during ZDI Debug mode. First, when the address and data bus are being used by an external source, ZDI must only access ZDI registers and internal CPU registers to prevent possible Bus contention. The bus acknowledge status is reported in the ZDI_BUS_STAT register. The BUSACK output pin also indicates the bus acknowledge state.

A second hazard is that when a bus acknowledge is granted, the ZDI is subject to any WAIT states that are assigned to the device currently being accessed by the external peripheral. To prevent data errors, ZDI should avoid data transmission while another device is controlling the bus.

Finally, exiting ZDI Debug mode while an external peripheral controls the address and data buses, as indicated by BUSACK assertion, may produce unpredictable results.

ZDI Write-Only Registers

Table 90 lists the ZDI Write-Only registers. Many of the ZDI Write-Only addresses are shared with ZDI Read-Only registers.

Table 90. ZDI Write-Only Registers

| ZDI Address | ZDI Register Name | ZDI Register Function | Reset Value |
|-------------|-------------------|----------------------------|-------------|
| 00h | ZDI_ADDR0_L | Address Match 0 Low Byte | XXh |
| 01h | ZDI_ADDR0_H | Address Match 0 High Byte | XXh |
| 02h | ZDI_ADDR0_U | Address Match 0 Upper Byte | XXh |
| 04h | ZDI_ADDR1_L | Address Match 1 Low Byte | XXh |
| 05h | ZDI_ADDR1_H | Address Match 1 High Byte | XXh |



Table 90. ZDI Write-Only Registers (Continued)

| ZDI Address | ZDI Register Name | ZDI Register Function | Reset Value |
|-------------|-------------------|-----------------------------|-------------|
| 06h | ZDI_ADDR1_U | Address Match 1 Upper Byte | XXh |
| 08h | ZDI_ADDR2_L | Address Match 2 Low Byte | XXh |
| 09h | ZDI_ADDR2_H | Address Match 2 High Byte | XXh |
| 0Ah | ZDI_ADDR2_U | Address Match 2 Upper Byte | XXh |
| 0Ch | ZDI_ADDR3_L | Address Match 3 Low Byte | XXh |
| 0Dh | ZDI_ADDR3_H | Address Match 3 High Byte | XXh |
| 0Eh | ZDI_ADDR3_U | Address Match 4 Upper Byte | XXh |
| 10h | ZDI_BRK_CTL | BREAK Control register | 00h |
| 11h | ZDI_MASTER_CTL | Master Control register | 00h |
| 13h | ZDI_WR_DATA_L | Write Data Low Byte | XXh |
| 14h | ZDI_WR_DATA_H | Write Data High Byte | XXh |
| 15h | ZDI_WR_DATA_U | Write Data Upper Byte | XXh |
| 16h | ZDI_RW_CTL | Read/Write Control register | 00h |
| 17h | ZDI_BUS_CTL | Bus Control register | 00h |
| 21h | ZDI_IS4 | Instruction Store 4 | XXh |
| 22h | ZDI_IS3 | Instruction Store 3 | XXh |
| 23h | ZDI_IS2 | Instruction Store 2 | XXh |
| 24h | ZDI_IS1 | Instruction Store 1 | XXh |
| 25h | ZDI_IS0 | Instruction Store 0 | XXh |
| 30h | ZDI_WR_MEM | Write Memory register | XXh |



ZDI Read-Only Registers

Table 91 lists the ZDI Read-Only registers. Many of the ZDI Read-Only addresses are shared with ZDI Write-Only registers.

Table 91. ZDI Read-Only Registers

| ZDI Address | ZDI Register Name | ZDI Register Function | Reset Value |
|-------------|-------------------|---|-------------|
| 00h | ZDI_ID_L | eZ80 [®] Product ID Low Byte register | 06h |
| 01h | ZDI_ID_H | eZ80 [®] Product ID High Byte register | 00h |
| 02h | ZDI_ID_REV | eZ80 [®] Product ID Revision register | XXh |
| 03h | ZDI_STAT | Status register | 00h |
| 10h | ZDI_RD_L | Read Memory Address Low Byte register | XXh |
| 11h | ZDI_RD_H | Read Memory Address High Byte register | XXh |
| 12h | ZDI_RD_U | Read Memory Address Upper Byte register | XXh |
| 17h | ZDI_BUS_STAT | Bus Status register | 00h |
| 20h | ZDI_RD_MEM | Read Memory Data Value | XXh |

ZDI Register Definitions

ZDI Address Match Registers

The four sets of address match registers are used for setting the addresses for generating BREAK points. When the accompanying BRK_ADDRx bit is set in the ZDI BREAK Control register to enable the particular address match, the current eZ80L92 address is compared with the 3-byte address set, {ZDI_ADDRx_U, ZDI_ADDRx_H, ZDI_ADDR_x_L}. If the CPU is operating in ADL mode, the address is supplied by ADDR[23:0]. If the CPU is operating in Z80 mode, the address is supplied by {MBase[7:0], ADDR[15:0]}. If a match is found, ZDI issues a BREAK to the eZ80L92 placing the processor in ZDI mode pending further instructions from the ZDI interface block. If the address is not the first op-code fetch, the ZDI BREAK is executed at the end of the instruction in which it is executed. There are four sets of address match registers. They can be used in conjunction with each other to BREAK on branching instructions. See Table 92.



Table 92. ZDI Address Match Registers
ZDI_ADDR0_L = 00h, ZDI_ADDR0_H = 01h, ZDI_ADDR0_U = 02h,
ZDI_ADDR1_L = 04h, ZDI_ADDR1_H = 05h, ZDI_ADDR1_U = 06h,
ZDI_ADDR2_L = 08h, ZDI_ADDR2_H = 09h, ZDI_ADDR2_U = 0Ah,
ZDI_ADDR3_L = 0Ch, ZDI_ADDR3_H = 0Dh, and ZDI_ADDR3_U = 0Eh
in the ZDI Register Write-Only Address Space

| | | | | | | | | |
|------------|---|---|---|---|---|---|---|---|
| Bit | 7 | 6 | 5 | 4 | 3 | 2 | 1 | 0 |
| Reset | X | X | X | X | X | X | X | X |
| CPU Access | W | W | W | W | W | W | W | W |

Note: W = Write-only.

| Bit Position | Value | Description |
|--|-------------|---|
| [7:0] ZDI_ADDRx_L, ZDI_ADDRx_H, or ZDI_ADDRx_U | 00h– FFh | The four sets of ZDI address match registers are used for setting the addresses for generating BREAK points. The 24-bit addresses are supplied by {ZDI_ADDRx_U, ZDI_ADDRx_H, ZDI_ADDRx_L, where x is 0, 1, 2, or 3. |

ZDI BREAK Control Register

The ZDI BREAK Control register is used to enable BREAK points. ZDI asserts a BREAK when the CPU instruction address, ADDR[23:0], matches the value in the ZDI Address Match 3 registers, {ZDI_ADDR3_U, ZDI_ADDR3_H, ZDI_ADDR3_L}. BREAKs can only occur on an instruction boundary. If the instruction address is not the beginning of an instruction (that is, for multibyte instructions), then the BREAK occurs at the end of the current instruction. The BRK_NEXT bit is set to 1. The BRK_NEXT bit must be reset to 0 to release the BREAK. See Table 93.



Table 93. ZDI BREAK Control Register
(ZDI_BRK_CTL = 10h in the ZDI Write-Only Register Address Space)

| Bit | 7 | 6 | 5 | 4 | 3 | 2 | 1 | 0 |
|------------|---|---|---|---|---|---|---|---|
| Reset | 0 | 0 | 0 | 0 | 0 | 0 | 0 | 0 |
| CPU Access | W | W | W | W | W | W | W | W |

Note: W = Write-only.

| Bit Position | Value | Description |
|----------------|-------|--|
| 7 BRK_NEXT | 0 | The ZDI BREAK on the next CPU instruction is disabled. Clearing this bit releases the CPU from its current BREAK condition. |
| | 1 | The ZDI BREAK on the next CPU instruction is enabled. The CPU can use multibyte Op Codes and multibyte operands. BREAK points only occur on the first Op Code in a multibyte Op Code instruction. If the ZCL pin is High and the ZDA pin is Low at the end of RESET, this bit is set to 1 and a BREAK occurs on the first instruction following the RESET. This bit is set automatically during ZDI BREAK on address match. A BREAK can also be forced by writing a 1 to this bit. |
| 6 BRK_ADDR3 | 0 | The ZDI BREAK, upon matching BREAK address 3, is disabled. |
| | 1 | The ZDI BREAK, upon matching BREAK address 3, is enabled. |
| 5 BRK_ADDR2 | 0 | The ZDI BREAK, upon matching BREAK address 2, is disabled. |
| | 1 | The ZDI BREAK, upon matching BREAK address 2, is enabled. |
| 4 BRK_ADDR1 | 0 | The ZDI BREAK, upon matching BREAK address 1, is disabled. |
| | 1 | The ZDI BREAK, upon matching BREAK address 1, is enabled. |
| 3 BRK_ADDR0 | 0 | The ZDI BREAK, upon matching BREAK address 0, is disabled. |
| | 1 | The ZDI BREAK, upon matching BREAK address 0, is enabled. |



| Bit Position | Value | Description |
|------------------|-------|---|
| 2 IGN_LOW_1 | 0 | The <i>Ignore the Low Byte</i> function of the ZDI Address Match 1 registers is disabled. If BRK_ADDR1 is set to 1, ZDI initiates a BREAK when the entire 24-bit address, ADDR[23:0], matches the 3-byte value {ZDI_ADDR1_U, ZDI_ADDR1_H, ZDI_ADDR1_L}. |
| | 1 | The <i>Ignore the Low Byte</i> function of the ZDI Address Match 1 registers is enabled. If BRK_ADDR1 is set to 1, ZDI initiates a BREAK when only the upper 2 bytes of the 24-bit address, ADDR[23:8], match the 2-byte value {ZDI_ADDR1_U, ZDI_ADDR1_H}. As a result, a BREAK can occur anywhere within a 256-byte page. |
| 1 IGN_LOW_0 | 0 | The <i>Ignore the Low Byte</i> function of the ZDI Address Match 1 registers is disabled. If BRK_ADDR0 is set to 1, ZDI initiates a BREAK when the entire 24-bit address, ADDR[23:0], matches the 3-byte value {ZDI_ADDR0_U, ZDI_ADDR0_H, ZDI_ADDR0_L}. |
| | 1 | The <i>Ignore the Low Byte</i> function of the ZDI Address Match 1 registers is enabled. If the BRK_ADDR1 is set to 0, ZDI initiates a BREAK when only the upper 2 bytes of the 24-bit address, ADDR[23:8], match the 2 bytes value {ZDI_ADDR0_U, ZDI_ADDR0_H}. As a result, a BREAK can occur anywhere within a 256-byte page. |
| 0 SINGLE_STEP | 0 | ZDI SINGLE STEP mode is disabled. |
| | 1 | ZDI SINGLE STEP mode is enabled. ZDI asserts a BREAK following execution of each instruction. |



ZDI Master Control Register

The ZDI Master Control register provides control of the eZ80L92. It is capable of forcing a RESET and waking up the eZ80L92 from the low-power modes (HALT or SLEEP). See Table 94.

Table 94. ZDI Master Control Register
(ZDI_MASTER_CTL = 11h in ZDI Register Write Address Spaces)

| | | | | | | | | |
|------------|---|---|---|---|---|---|---|---|
| Bit | 7 | 6 | 5 | 4 | 3 | 2 | 1 | 0 |
| Reset | 0 | 0 | 0 | 0 | 0 | 0 | 0 | 0 |
| CPU Access | W | W | W | W | W | W | W | W |

Note: W = Write-only.

| Bit Position | Value | Description |
|--------------|---------|---|
| 7 | 0 | No action. |
| ZDI_RESET | 1 | Initiate a RESET of the eZ80L92. This bit is automatically cleared at the end of the RESET event. |
| [6:0] | 0000000 | Reserved. |



ZDI Write Data Registers

These three registers are used in the ZDI Write-Only register address space to store the data that is written when a Write instruction is sent to the ZDI Read/Write Control register (ZDI_RW_CTL). The ZDI Read/Write Control register is located at ZDI address 16h immediately following the ZDI Write Data registers. As a result, the ZDI Master is allowed to write the data to {ZDI_WR_U, ZDI_WR_H, ZDI_WR_L} and the Write command in one data transfer operation. See Table 95.

Table 95. ZDI Write Data Registers
(ZDI_WR_U = 13h, ZDI_WR_H = 14h, and ZDI_WR_L = 15h
in the ZDI Register Write-Only Address Space)

| Bit | 7 | 6 | 5 | 4 | 3 | 2 | 1 | 0 |
|------------|---|---|---|---|---|---|---|---|
| Reset | X | X | X | X | X | X | X | X |
| CPU Access | W | W | W | W | W | W | W | W |

Note: X = Undefined; W = Write.

| Bit Position | Value | Description |
|---|-------------|---|
| [7:0] ZDI_WR_L, ZDI_WR_H, or ZDI_WR_L | 00h– FFh | These registers contain the data that is written during execution of a Write operation defined by the ZDI_RW_CTL register. The 24-bit data value is stored as {ZDI_WR_U, ZDI_WR_H, ZDI_WR_L}. If less than 24 bits of data are required to complete the required operation, the data is taken from the least significant byte(s). |

ZDI Read/Write Control Register

The ZDI Read/Write Control register is used in the ZDI Write-Only Register address to read data from, write data to, and manipulate the CPU's registers or memory locations. When this register is written, the eZ80L92 immediately performs the operation corresponding to the data value written as described in Table 96. When a Read operation is executed via this register, the requested data values are placed in the ZDI Read Data registers {ZDI_RD_U, ZDI_RD_H, ZDI_RD_L}. When a Write operation is executed via this register, the Write data is taken from the ZDI Write Data registers {ZDI_WR_U, ZDI_WR_H, ZDI_WR_L}. See Table 96. Refer to the eZ80 CPU User Manual (UM0077) for information regarding the CPU registers.



Table 96. ZDI Read/Write Control Register Functions
(ZDI_RW_CTL = 16h in the ZDI Register Write-Only Address Space)

| Hex Value | Command | Hex Value | Command |
|-----------|--|-----------|---|
| 00 | Read {MBASE, A, F} ZDI_RD_U ← MBASE ZDI_RD_H ← F ZDI_RD_L ← A | 80 | Write {MBASE, A, F} MBASE ← ZDI_WR_U F ← ZDI_WR_H A ← ZDI_WR_L |
| 01 | Read BC ZDI_RD_U ← BCU ZDI_RD_H ← B ZDI_RD_L ← C | 81 | Write BC BCU ← ZDI_WR_U B ← ZDI_WR_H C ← ZDI_WR_L |
| 02 | Read DE ZDI_RD_U ← DEU ZDI_RD_H ← D ZDI_RD_L ← E | 82 | Write DE DEU ← ZDI_WR_U D ← ZDI_WR_H E ← ZDI_WR_L |
| 03 | Read HL ZDI_RD_U ← HLU ZDI_RD_H ← H ZDI_RD_L ← L | 83 | Write HL HLU ← ZDI_WR_U H ← ZDI_WR_H L ← ZDI_WR_L |
| 04 | Read IX ZDI_RD_U ← IXU ZDI_RD_H ← IXH ZDI_RD_L ← IXL | 84 | Write IX IXU ← ZDI_WR_U IXH ← ZDI_WR_H IXL ← ZDI_WR_L |
| 05 | Read IY ZDI_RD_U ← IYU ZDI_RD_H ← IYH ZDI_RD_L ← IYL | 85 | Write IY IYU ← ZDI_WR_U IYH ← ZDI_WR_H IYL ← ZDI_WR_L |
| 06 | Read SP In ADL mode, SP = SPL. In Z80 mode, SP = SPS. | 86 | Write SP In ADL mode, SP = SPL. In Z80 mode, SP = SPS. |
| 07 | Read PC ZDI_RD_U ← PC[23:16] ZDI_RD_H ← PC[15:8] ZDI_RD_L ← PC[7:0] | 87 | Write PC PC[23:16] ← ZDI_WR_U PC[15:8] ← ZDI_WR_H PC[7:0] ← ZDI_WR_L |
| 08 | Set ADL ADL ← 1 | 88 | Reserved |

Note: The eZ80[®] CPU's alternate register set (A', F', B', C', D', E', HL') cannot be read directly. The ZDI programmer must execute the exchange instruction (EXX) to gain access to the alternate eZ80[®] CPU register set.



Table 96. ZDI Read/Write Control Register Functions
(ZDI_RW_CTL = 16h in the ZDI Register Write-Only Address Space) (Continued)

| Hex Value | Command | Hex Value | Command |
|-----------|--|-----------|--|
| 09 | Reset ADL ADL ← 0 | 89 | Reserved |
| 0A | Exchange CPU register sets AF ← AF' BC ← BC' DE ← DE' HL ← HL' | 8A | Reserved |
| 0B | Read memory from current PC value, increment PC | 8B | Write memory from current PC value, increment PC |

Note: The eZ80[®] CPU's alternate register set (A', F', B', C', D', E', HL') cannot be read directly. The ZDI programmer must execute the exchange instruction (EXX) to gain access to the alternate eZ80[®] CPU register set.

ZDI Bus Control Register

The ZDI Bus Control register controls bus requests during DEBUG mode. It enables or disables bus acknowledge in ZDI DEBUG mode and allows ZDI to force assertion of the BUSACK signal. This register should only be written during ZDI Debug mode (that is, following a BREAK). See Table 97.

Table 97. ZDI Bus Control Register
(ZDI_BUS_CTL = 17h in the ZDI Register Write-Only Address Space)

| Bit | 7 | 6 | 5 | 4 | 3 | 2 | 1 | 0 |
|------------|---|---|---|---|---|---|---|---|
| Reset | 0 | 0 | 0 | 0 | 0 | 0 | 0 | 0 |
| CPU Access | W | W | W | W | W | W | W | W |

Note: W = Write-only.

| Bit Position | Value | Description |
|-------------------|-------|--|
| 7 ZDI_BUSAK_EN | 0 | Bus requests by external peripherals using the BUSREQ pin are ignored. The bus acknowledge signal, BUSACK, is not asserted in response to any bus requests. |
| | 1 | Bus requests by external peripherals using the BUSREQ pin are accepted. A bus acknowledge occurs at the end of the current ZDI operation. The bus acknowledge is indicated by asserting the BUSACK pin in response to a bus request. |



| Bit Position | Value | Description |
|----------------|--------|--|
| 6 ZDI_BUSAK | 0 | Deassert the bus acknowledge pin (BUSACK) to return control of the address and data buses back to ZDI. |
| | 1 | Assert the bus acknowledge pin (BUSACK) to pass control of the address and data buses to an external peripheral. |
| [5:0] | 000000 | Reserved. |

Instruction Store 4:0 Registers

The ZDI Instruction Store registers are located in the ZDI Register Write-Only address space. They can be written with instruction data for direct execution by the CPU. When the ZDI_IS0 register is written, the eZ80L92 exits the ZDI BREAK state and executes a single instruction. The Op Codes and operands for the instruction come from these Instruction Store registers. The Instruction Store Register 0 is the first byte fetched, followed by Instruction Store registers 1, 2, 3, and 4, as necessary. Only the bytes the processor requires to execute the instruction must be stored in these registers. Some eZ80[®] instructions, when combined with the MEMORY mode suffixes (.SIS, .SIL, .LIS, or .LIL), require 6 bytes to operate. These 6-byte instructions cannot be executed directly using the ZDI Instruction Store registers. See Table 98.

- **Note:** The Instruction Store 0 register is located at a higher ZDI address than the other Instruction Store registers. This feature allows the use of the ZDI auto-address increment function to load and execute a multibyte instruction with a single data stream from the ZDI master. Execution of the instruction commences with writing the final byte to ZDI_IS0.



Table 98. Instruction Store 4:0 Registers
(ZDI_IS4 = 21h, ZDI_IS3 = 22h, ZDI_IS2 = 23h, ZDI_IS1 = 24h, and ZDI_IS0 = 25h
in the ZDI Register Write-Only Address Space)

| Bit | 7 | 6 | 5 | 4 | 3 | 2 | 1 | 0 |
|------------|---|---|---|---|---|---|---|---|
| Reset | X | X | X | X | X | X | X | X |
| CPU Access | W | W | W | W | W | W | W | W |

Note: X = Undefined; W = Write.

| Bit Position | Value | Description |
|--|-------------|---|
| [7:0] ZDI_IS4, ZDI_IS3, ZDI_IS2, ZDI_IS1, or ZDI_IS0 | 00h– FFh | These registers contain the Op Codes and operands for immediate execution by the CPU following a Write to ZDI_IS0. The ZDI_IS0 register contains the first Op Code of the instruction. The remaining ZDI_ISx registers contain any additional Op Codes or operand dates required for execution of the required instruction. |

ZDI Write Memory Register

A Write to the ZDI Write Memory register causes the eZ80L92 to write the 8-bit data to the memory location specified by the current address in the program counter. In Z80 MEMORY mode, this address is {MBASE, PC[15:0]}. In ADL MEMORY mode, this address is PC[23:0]. The program counter, PC, increments after each data Write. However, the ZDI register address does not increment automatically when this register is accessed. As a result, the ZDI master is allowed to write any number of data bytes by writing to this address one time followed by any number of data bytes. See Table 99.



Table 99. ZDI Write Memory Register
(ZDI_WR_MEM = 30h in the ZDI Register Write-Only Address Space)

| Bit | 7 | 6 | 5 | 4 | 3 | 2 | 1 | 0 |
|------------|---|---|---|---|---|---|---|---|
| Reset | X | X | X | X | X | X | X | X |
| CPU Access | W | W | W | W | W | W | W | W |

Note: X = Undefined; W = Write.

| Bit Position | Value | Description |
|---------------------|-------------|--|
| [7:0] ZDI_WR_MEM | 00h– FFh | The 8-bit data that is transferred to the ZDI slave following a Write to this address is written to the address indicated by the current program counter. The program counter is incremented following each 8 bits of data. In Z80 MEMORY mode, ({MBASE, PC[15:0]}) ← 8 bits of transferred data. In ADL MEMORY mode, (PC[23:0]) ← 8 bits of transferred data. |

eZ80[®] Product ID Low and High Byte Registers

The eZ80[®] Product ID Low and High Byte registers combine to provide a means for an external device to determine the particular eZ80[®] product being addressed. For the eZ80L92, these two bytes, {ZDI_ID_H, ZDI_ID_L} return the value {00h, 06h}. See Tables 100 and 101.

Table 100. eZ80[®] Product ID Low Byte Register
(ZDI_ID_L = 00h in the ZDI Register Read-Only Address Space)

| Bit | 7 | 6 | 5 | 4 | 3 | 2 | 1 | 0 |
|------------|---|---|---|---|---|---|---|---|
| Reset | 0 | 0 | 0 | 0 | 0 | 1 | 1 | 0 |
| CPU Access | R | R | R | R | R | R | R | R |

Note: R = Read-only.

| Bit Position | Value | Description |
|-------------------|-------|--|
| [7:0] ZDI_ID_L | 06h | {ZDI_ID_H, ZDI_ID_L} = {00h, 06h} indicates the eZ80L92 product. |



**Table 101. eZ80[®] Product ID High Byte Register
(ZDI_ID_H = 01h in the ZDI Register Read-Only Address Space)**

| | | | | | | | | |
|------------|---|---|---|---|---|---|---|---|
| Bit | 7 | 6 | 5 | 4 | 3 | 2 | 1 | 0 |
| Reset | 0 | 0 | 0 | 0 | 0 | 0 | 0 | 0 |
| CPU Access | R | R | R | R | R | R | R | R |

Note: R = Read-only.

| Bit Position | Value | Description |
|-------------------|-------|--|
| [7:0] ZDI_ID_H | 00h | {ZDI_ID_H, ZDI_ID_L} = {00h, 06h} indicates the eZ80L92 product. |

eZ80[®] Product ID Revision Register

The eZ80[®] Product ID Revision register identifies the current revision of the eZ80L92 product. See Table 102.

**Table 102. eZ80[®] Product ID Revision Register
(ZDI_ID_REV = 02h in the ZDI Register Read-Only Address Space)**

| | | | | | | | | |
|------------|---|---|---|---|---|---|---|---|
| Bit | 7 | 6 | 5 | 4 | 3 | 2 | 1 | 0 |
| Reset | X | X | X | X | X | X | X | X |
| CPU Access | R | R | R | R | R | R | R | R |

Note: X = Undetermined; R = Read-only.

| Bit Position | Value | Description |
|---------------------|-------------|---|
| [7:0] ZDI_ID_REV | 00h– FFh | Identifies the current revision of the eZ80L92 product. |



ZDI Status Register

The ZDI Status register provides current information on the eZ80L92 and the eZ80[®] CPU. See Table 103.

Table 103. ZDI Status Register
(ZDI_STAT = 03h in the ZDI Register Read-Only Address Space)

| Bit | 7 | 6 | 5 | 4 | 3 | 2 | 1 | 0 |
|------------|---|---|---|---|---|---|---|---|
| Reset | 0 | 0 | 0 | 0 | 0 | 0 | 0 | 0 |
| CPU Access | R | R | R | R | R | R | R | R |

Note: R = Read-only.

| Bit Position | Value | Description |
|-------------------|-------|--|
| 7 ZDI_ACTIVE | 0 | The CPU is not functioning in ZDI mode. |
| | 1 | The CPU is currently functioning in ZDI mode. |
| 6 | 0 | Reserved. |
| 5 HALT_SLP | 0 | eZ80L92 is not currently in HALT or SLEEP mode. |
| | 1 | eZ80L92 is currently in HALT or SLEEP mode. |
| 4 ADL | 0 | The CPU is operating in Z80 MEMORY mode. (ADL bit = 0). |
| | 1 | The CPU is operating in ADL MEMORY mode. (ADL bit = 1). |
| 3 MADL | 0 | The CPU's Mixed-Memory mode (MADL) bit is reset to 0. |
| | 1 | The CPU's Mixed-Memory mode (MADL) bit is set to 1. |
| 2 IEF1 | 0 | The CPU's Interrupt Enable Flag 1 is reset to 0. Maskable interrupts are disabled. |
| | 1 | The CPU's Interrupt Enable Flag 1 is set to 1. Maskable interrupts are enabled. |
| [1:0] RESERVED | 00 | Reserved. |

ZDI Read Registers—Low, High, and Upper

The ZDI register Read-Only address space offers Low, High, and Upper functions, which contain the value read by a Read operation from the ZDI Read/Write Control register (ZDI_RW_CTL). This data is valid only while in ZDI BREAK mode and only if the instruction is read by a request from the ZDI Read/Write Control register. See Table 104.



**Table 104. ZDI Read Registers—Low, High and Upper
(ZDI_RD_L = 10h, ZDI_RD_H = 11h, and ZDI_RD_U = 12h
in the ZDI Register Read-Only Address Space)**

| | | | | | | | | |
|------------|---|---|---|---|---|---|---|---|
| Bit | 7 | 6 | 5 | 4 | 3 | 2 | 1 | 0 |
| Reset | 0 | 0 | 0 | 0 | 0 | 0 | 0 | 0 |
| CPU Access | R | R | R | R | R | R | R | R |

Note: R = Read-only.

| Bit Position | Value | Description |
|---|-------------|---|
| [7:0] ZDI_RD_L, ZDI_RD_H, or ZDI_RD_U | 00h– FFh | Values read from the memory location as requested by the ZDI Read Control register during a ZDI Read operation. The 24-bit value is supplied by {ZDI_RD_U, ZDI_RD_H, ZDI_RD_L}. |



ZDI Bus Status Register

The ZDI Bus Status register monitors BUSACKs during DEBUG mode. See Table 105.

Table 105. ZDI Bus Control Register
(ZDI_BUS_STAT = 17h in the ZDI Register Read-Only Address Space)

| | | | | | | | | |
|------------|---|---|---|---|---|---|---|---|
| Bit | 7 | 6 | 5 | 4 | 3 | 2 | 1 | 0 |
| Reset | 0 | 0 | 0 | 0 | 0 | 0 | 0 | 0 |
| CPU Access | R | R | R | R | R | R | R | R |

Note: R = Read-Only.

| Bit Position | Value | Description |
|--------------------|--------|---|
| 7 ZDI_BUSACK_EN | 0 | Bus requests by external peripherals using the BUSREQ pin are ignored. The bus acknowledge signal, BUSACK, is not asserted. |
| | 1 | Bus requests by external peripherals using the BUSREQ pin are accepted. A bus acknowledge occurs at the end of the current ZDI operation. The bus acknowledge is indicated by asserting the BUSACK pin. |
| 6 ZDI_BUS_STAT | 0 | Address and data buses are not relinquished to an external peripheral. bus acknowledge is deasserted (BUSACK pin is High). |
| | 1 | Address and data buses are relinquished to an external peripheral. bus acknowledge is asserted (BUSACK pin is Low). |
| [5:0] | 000000 | Reserved. |

ZDI Read Memory Register

When a Read is executed from the ZDI Read Memory register, the eZ80L92 fetches the data from the memory address currently pointed to by the program counter, PC; the program counter is then incremented. In Z80 MEMORY mode, the memory address is {MBASE, PC[15:0]}. In ADL MEMORY mode, the memory address is PC[23:0]. Refer to the eZ80 CPU User Manual (UM0077) for more information regarding Z80 and ADL MEMORY modes. The program counter, PC, increments after each data Read. However, the ZDI register address does not increment automatically when this register is accessed. As a result, the ZDI master can read any number of data bytes out of memory through the ZDI Read Memory register. See Table 106.



**Table 106. ZDI Read Memory Register
(ZDI_RD_MEM = 20h in the ZDI Register Read-Only Address Space)**

| | | | | | | | | |
|------------|---|---|---|---|---|---|---|---|
| Bit | 7 | 6 | 5 | 4 | 3 | 2 | 1 | 0 |
| Reset | 0 | 0 | 0 | 0 | 0 | 0 | 0 | 0 |
| CPU Access | R | R | R | R | R | R | R | R |

Note: R = Read-only.

| Bit Position | Value | Description |
|---------------------|-------------|--|
| [7:0] ZDI_RD_MEM | 00h– FFh | 8-bit data read from the memory address indicated by the CPU's program counter. In Z80 MEMORY mode, 8-bit data is transferred out from address {MBASE, PC[15:0]}. In ADL Memory mode, 8-bit data is transferred out from address PC[23:0]. |



On-Chip Instrumentation

Introduction to On-Chip Instrumentation

On-Chip Instrumentation¹ (OCI™) for the ZiLOG eZ80[®] CPU core enables powerful debugging features. The OCI provides run control, memory and register visibility, complex breakpoints, and trace history features.

The OCI employs all of the functions of the ZiLOG Debug Interface (ZDI) as described in the ZDI section. It also adds the following debug features:

- Control via a 4-pin JTAG port that conforms to IEEE Standard 1149.1 (Test Access Port and Boundary-Scan Architecture)²
- Complex breakpoint trigger functions
- Breakpoint enhancements, such as the ability to:
 - Define two breakpoint addresses that form a range
 - Break on masked data values
 - Start or stop trace
 - Assert a trigger output signal
- Trace history buffer
- Software breakpoint instruction

There are four sections to the OCI:

1. JTAG interface
2. ZDI debug control
3. Trace buffer memory
4. Complex triggers

OCI Activation

OCI features clock initialization circuitry so that external debug hardware can be detected during power up. The external debugger must drive the OCI clock pin (TCK) Low at least two system clock cycles prior to the end of the RESET to activate the OCI block. If TCK is High at the end of the RESET, the OCI block shuts down so that it does not draw power in normal product operation. When the OCI is

1. On-Chip Instrumentation and OCI are trademarks of First Silicon Solutions, Inc.
2. The eZ80L92 does not contain the boundary scan register required for 1149.1 compliance.



shut down, ZDI is enabled directly and can be accessed through the clock (TCK) and data (TDI) pins. See the [ZiLOG Debug Interface](#) section on page 156 for more information on ZDI.

OCI Interface

There are five dedicated pins on the eZ80L92 for the OCI interface. Four (TCK, TMS, TDI, and TDO) are required for IEEE Standard 1149.1-compatible JTAG ports. The TRIGOUT pin provides additional testability features. These five OCI pins are described in Table 107.

Table 107. OCI Pins

| Symbol | Name | Type | Description |
|---------|------------------|------------------------|--|
| TCK | Clock. | Input | Asynchronous to the primary eZ80L92 system clock. The TCK period must be at least twice the system clock period. During RESET, this pin is sampled to select either OCI or ZDI DEBUG modes. If Low during RESET, the OCI is enabled. If High during RESET, the OCI is powered down and ZDI DEBUG mode is enabled. When ZDI DEBUG mode is active, this pin is the ZDI clock. On-chip pull-up ensures a default value of 1 (High). |
| TMS | Test Mode Select | Input | This serial test mode input controls JTAG mode selection. On-chip pull-up ensures a default value of 1 (High). The TMS signal is sampled on the rising edge of the TCK signal. |
| TDI | Data In | Input (OCI enabled) | Serial test data input. On-chip pull-up ensures a default value of 1 (High). This pin is input-only when the OCI is enabled. The input data is sampled on the rising edge of the TCK signal. |
| | | I/O (OCI disabled) | When the OCI is disabled, this pin functions as the ZDA (ZDI Data) I/O pin. |
| TDO | Data Out | Output | The output data changes on the falling edge of the TCK signal. |
| TRIGOUT | Trigger Output | Output | Generates an active High trigger pulse when valid OCI trigger events occur. Output is tristate when no data is being driven out. |



OCI Information Requests

For additional information regarding On-Chip Instrumentation, or to order OCI debug tools, please contact:

First Silicon Solutions, Inc.
5440 SW Westgate Drive, Suite 240
Portland, OR 97221
Phone: (503) 292-6730
Fax: (503) 292-5840
www.fs2.com



eZ80[®] CPU Instruction Set

Tables 108 through 117 indicate the eZ80[®] CPU instructions available for use with the eZ80L92. The instructions are grouped by class. More detailed information is available in the eZ80[®] CPU User Manual.

Table 108. Arithmetic Instructions

| Mnemonic | Instruction |
|-----------------|----------------------------|
| ADC | Add with Carry |
| ADD | Add without Carry |
| CP | Compare with Accumulator |
| DAA | Decimal Adjust Accumulator |
| DEC | Decrement |
| INC | Increment |
| MLT | Multiply |
| NEG | Negate Accumulator |
| SBC | Subtract with Carry |
| SUB | Subtract without Carry |

Table 109. Bit Manipulation Instructions

| Mnemonic | Instruction |
|-----------------|--------------------|
| BIT | Bit Test |
| RES | Reset Bit |
| SET | Set Bit |

Table 110. Block Transfer and Compare Instructions

| Mnemonic | Instruction |
|-----------------|-------------------------------------|
| CPD (CPDR) | Compare and Decrement (with Repeat) |
| CPI (CPIR) | Compare and Increment (with Repeat) |
| LDD (LDDR) | Load and Decrement (with Repeat) |
| LDI (LDIR) | Load and Increment (with Repeat) |



Table 111. Exchange Instructions

| Mnemonic | Instruction |
|----------|---------------------------------------|
| EX | Exchange registers |
| EXX | Exchange CPU Multibyte register banks |

Table 112. Input/Output Instructions

| Mnemonic | Instruction |
|---------------|---|
| IN | Input from I/O |
| IN0 | Input from I/O on Page 0 |
| IND (INDR) | Input from I/O and Decrement (with Repeat) |
| INDRX | Input from I/O and Decrement Memory Address with Stationary I/O Address |
| IND2 (IND2R) | Input from I/O and Decrement (with Repeat) |
| INDM (INDMR) | Input from I/O and Decrement (with Repeat) |
| INI (INIR) | Input from I/O and Increment (with Repeat) |
| INIRX | Input from I/O and Increment Memory Address with Stationary I/O Address |
| INI2 (INI2R) | Input from I/O and Increment (with Repeat) |
| INIM (INIMR) | Input from I/O and Increment (with Repeat) |
| OTDM (OTDMR) | Output to I/O and Decrement (with Repeat) |
| OTDRX | Output to I/O and Decrement Memory Address with Stationary I/O Address |
| OTIM (OTIMR) | Output to I/O and Increment (with Repeat) |
| OTIRX | Output to I/O and Increment Memory Address with Stationary I/O Address |
| OUT | Output to I/O |
| OUT0 | Output to I/O on Page 0 |
| OUTD (OTDR) | Output to I/O and Decrement (with Repeat) |
| OUTD2 (OTD2R) | Output to I/O and Decrement (with Repeat) |
| OUTI (OTIR) | Output to I/O and Increment (with Repeat) |
| OUTI2 (OTI2R) | Output to I/O and Increment (with Repeat) |
| TSTIO | Test I/O |

**Table 113. Load Instructions**

| Mnemonic | Instruction |
|-----------------|------------------------|
| LD | Load |
| LEA | Load Effective Address |
| PEA | Push Effective Address |
| POP | Pop |
| PUSH | Push |

Table 114. Logical Instructions

| Mnemonic | Instruction |
|-----------------|------------------------|
| AND | Logical AND |
| CPL | Complement Accumulator |
| OR | Logical OR |
| TST | Test Accumulator |
| XOR | Logical Exclusive OR |

Table 115. Processor Control Instructions

| Mnemonic | Instruction |
|-----------------|------------------------------|
| CCF | Complement Carry Flag |
| DI | Disable Interrupts |
| EI | Enable Interrupts |
| HALT | Halt |
| IM | Interrupt Mode |
| NOP | No Operation |
| RSMIX | Reset Mixed-Memory Mode Flag |
| SCF | Set Carry Flag |
| SLP | Sleep |
| STMIX | Set Mixed-Memory Mode Flag |

**Table 116. Program Control Instructions**

| Mnemonic | Instruction |
|-----------------|-----------------------------------|
| CALL | Call Subroutine |
| CALL cc | Conditional Call Subroutine |
| DJNZ | Decrement and Jump if Nonzero |
| JP | Jump |
| JP cc | Conditional Jump |
| JR | Jump Relative |
| JR cc | Conditional Jump Relative |
| RET | Return |
| RET cc | Conditional Return |
| RETI | Return from Interrupt |
| RETN | Return from Nonmaskable interrupt |
| RST | Restart |

Table 117. Rotate and Shift Instructions

| Mnemonic | Instruction |
|-----------------|-----------------------------------|
| RL | Rotate Left |
| RLA | Rotate Left–Accumulator |
| RLC | Rotate Left Circular |
| RLCA | Rotate Left Circular–Accumulator |
| RLD | Rotate Left Decimal |
| RR | Rotate Right |
| RRA | Rotate Right–Accumulator |
| RRC | Rotate Right Circular |
| RRCA | Rotate Right Circular–Accumulator |
| RRD | Rotate Right Decimal |
| SLA | Shift Left Arithmetic |
| SRA | Shift Right Arithmetic |
| SRL | Shift Right Logical |



Op-Code Map

Tables 118 through 124 indicate the hex values for each of the eZ80[®] instructions.

Table 118. Op Code Map—First Op Code

Legend

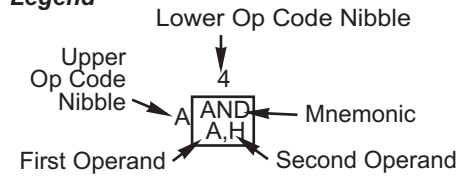

| | | Lower Nibble (Hex) | | | | | | | | | | | | | | | |
|--------------------|---|--------------------|------------|--------------|------------|--------------|-----------|------------|-----------|-----------|-------------|--------------|---------------------------|--------------|---------------------------|------------|---------|
| | | 0 | 1 | 2 | 3 | 4 | 5 | 6 | 7 | 8 | 9 | A | B | C | D | E | F |
| Upper Nibble (Hex) | 0 | NOP | LD BC, Mmn | LD (BC),A | INC BC | INC B | DEC B | LD B,n | RLCA | EX AF,AF' | ADD HL,BC | LD A,(BC) | DEC BC | INC C | DEC C | LD C,n | RRCA |
| | 1 | DJNZ d | LD DE, Mmn | LD (DE),A | INC DE | INC D | DEC D | LD D,n | RLA | JR d | ADD HL,DE | LD A,(DE) | DEC DE | INC E | DEC E | LD E,n | RRA |
| | 2 | JR NZ,d | LD HL, Mmn | LD (Mmn), HL | INC HL | INC H | DEC H | LD H,n | DAA | JR Z,d | ADD HL,HL | LD HL, (Mmn) | DEC HL | INC L | DEC L | LD L,n | CPL |
| | 3 | JR NC,d | LD SP, Mmn | LD (Mmn), A | INC SP | INC (HL) | DEC (HL) | LD (HL),n | SCF | JR CF,d | ADD HL,SP | LD A, (Mmn) | DEC SP | INC A | DEC A | LD A,n | CCF |
| | 4 | .SIS suffix | LD B,C | LD B,D | LD B,E | LD B,H | LD B,L | LD B,(HL) | LD B,A | LD C,B | .LIS suffix | LD C,D | LD C,E | LD C,H | LD C,L | LD C,(HL) | LD C,A |
| | 5 | LD D,B | LD D,C | .SIL suffix | LD D,E | LD D,H | LD D,L | LD D,(HL) | LD D,A | LD D,E | LD D,B | LD D,C | LD D,E | .LIL suffix | LD D,H | LD D,(HL) | LD D,E |
| | 6 | LD H,B | LD H,C | LD H,D | LD H,E | LD H,H | LD H,L | LD H,(HL) | LD H,A | LD L,B | LD L,C | LD L,D | LD L,E | LD L,H | LD L,L | LD L,(HL) | LD L,A |
| | 7 | LD (HL),B | LD (HL),C | LD (HL),D | LD (HL),E | LD (HL),H | LD (HL),L | HALT | LD (HL),A | LD A,B | LD A,C | LD A,D | LD A,E | LD A,H | LD A,L | LD A,(HL) | LD A,A |
| | 8 | ADD A,B | ADD A,C | ADD A,D | ADD A,E | ADD A,H | ADD A,L | ADD A,(HL) | ADD A,A | ADC A,B | ADC A,C | ADC A,D | ADC A,E | ADC A,H | ADC A,L | ADC A,(HL) | ADC A,A |
| | 9 | SUB A,B | SUB A,C | SUB A,D | SUB A,E | SUB A,H | SUB A,L | SUB A,(HL) | SUB A,A | SBC A,B | SBC A,C | SBC A,D | SBC A,E | SBC A,H | SBC A,L | SBC A,(HL) | SBC A,A |
| | A | AND A,B | AND A,C | AND A,D | AND A,E | AND A,H | AND A,L | AND A,(HL) | AND A,A | XOR A,B | XOR A,C | XOR A,D | XOR A,E | XOR A,H | XOR A,L | XOR A,(HL) | XOR A,A |
| | B | OR A,B | OR A,C | OR A,D | OR A,E | OR A,H | OR A,L | OR A,(HL) | OR A,A | CP A,B | CP A,C | CP A,D | CP A,E | CP A,H | CP A,L | CP A,(HL) | CP A,A |
| | C | RET NZ | POP BC | JP NZ, Mmn | JP Mmn | CALL NZ, Mmn | PUSH BC | ADD A,n | RST 00h | RET Z | RET | JP Z, Mmn | Table 119 | CALL Z, Mmn | CALL Mmn | ADC A,n | RST 08h |
| | D | RET NC | POP DE | JP NC, Mmn | OUT (n),A | CALL NC, Mmn | PUSH DE | SUB A,n | RST 10h | RET CF | EXX | JP CF, Mmn | IN A,(n) | CALL CF, Mmn | Table 120 | SBC A,n | RST 18h |
| | E | RET PO | POP HL | JP PO, Mmn | EX (SP),HL | CALL PO, Mmn | PUSH HL | AND A,n | RST 20h | RET PE | JP (HL) | JP PE, Mmn | EX DE,HL | CALL PE, Mmn | Table 121 | XOR A,n | RST 28h |
| | F | RET P | POP AF | JP P, Mmn | DI | CALL P, Mmn | PUSH AF | OR A,n | RST 30h | RET M | LD SP,HL | JP M, Mmn | EI | CALL M, Mmn | Table 122 | CP A,n | RST 38h |

Notes: n = 8-bit data; Mmn = 16- or 24-bit addr or data; d = 8-bit two's-complement displacement.



Table 119.Op Code Map—Second Op Code after 0CBh

Legend

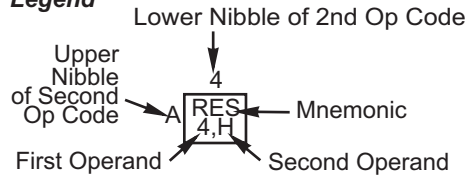

| | | Lower Nibble (Hex) | | | | | | | | | | | | | | | |
|--------------------|---|--------------------|------------|------------|------------|------------|------------|---------------|------------|------------|------------|------------|------------|------------|------------|---------------|------------|
| | | 0 | 1 | 2 | 3 | 4 | 5 | 6 | 7 | 8 | 9 | A | B | C | D | E | F |
| Upper Nibble (Hex) | 0 | RLC B | RLC C | RLC D | RLC E | RLC H | RLC L | RLC (HL) | RLC A | RRC B | RRC C | RRC D | RRC E | RRC H | RRC L | RRC (HL) | RRC A |
| | 1 | RL B | RL C | RL D | RL E | RL H | RL L | RL (HL) | RL A | RR B | RR C | RR D | RR E | RR H | RR L | RR (HL) | RR A |
| | 2 | SLA B | SLA C | SLA D | SLA E | SLA H | SLA L | SLA (HL) | SLA A | SRA B | SRA C | SRA D | SRA E | SRA H | SRA L | SRA (HL) | SRA A |
| | 3 | | | | | | | | | SRL B | SRL C | SRL D | SRL E | SRL H | SRL L | SRL (HL) | SRL A |
| | 4 | BIT 0,B | BIT 0,C | BIT 0,D | BIT 0,E | BIT 0,H | BIT 0,L | BIT 0,(HL) | BIT 0,A | BIT 1,B | BIT 1,C | BIT 1,D | BIT 1,E | BIT 1,H | BIT 1,L | BIT 1,(HL) | BIT 1,A |
| | 5 | BIT 2,B | BIT 2,C | BIT 2,D | BIT 2,E | BIT 2,H | BIT 2,L | BIT 2,(HL) | BIT 2,A | BIT 3,B | BIT 3,C | BIT 3,D | BIT 3,E | BIT 3,H | BIT 3,L | BIT 3,(HL) | BIT 3,A |
| | 6 | BIT 4,B | BIT 4,C | BIT 4,D | BIT 4,E | BIT 4,H | BIT 4,L | BIT 4,(HL) | BIT 4,A | BIT 5,B | BIT 5,C | BIT 5,D | BIT 5,E | BIT 5,H | BIT 5,L | BIT 5,(HL) | BIT 5,A |
| | 7 | BIT 6,B | BIT 6,C | BIT 6,D | BIT 6,E | BIT 6,H | BIT 6,L | BIT 6,(HL) | BIT 6,A | BIT 7,B | BIT 7,C | BIT 7,D | BIT 7,E | BIT 7,H | BIT 7,L | BIT 7,(HL) | BIT 7,A |
| | 8 | RES 0,B | RES 0,C | RES 0,D | RES 0,E | RES 0,H | RES 0,L | RES 0,(HL) | RES 0,A | RES 1,B | RES 1,C | RES 1,D | RES 1,E | RES 1,H | RES 1,L | RES 1,(HL) | RES 1,A |
| | 9 | RES 2,B | RES 2,C | RES 2,D | RES 2,E | RES 2,H | RES 2,L | RES 2,(HL) | RES 2,A | RES 3,B | RES 3,C | RES 3,D | RES 3,E | RES 3,H | RES 3,L | RES 3,(HL) | RES 3,A |
| | A | RES 4,B | RES 4,C | RES 4,D | RES 4,E | RES 4,H | RES 4,L | RES 4,(HL) | RES 4,A | RES 5,B | RES 5,C | RES 5,D | RES 5,E | RES 5,H | RES 5,L | RES 5,(HL) | RES 5,A |
| | B | RES 6,B | RES 6,C | RES 6,D | RES 6,E | RES 6,H | RES 6,L | RES 6,(HL) | RES 6,A | RES 7,B | RES 7,C | RES 7,D | RES 7,E | RES 7,H | RES 7,L | RES 7,(HL) | RES 7,A |
| | C | SET 0,B | SET 0,C | SET 0,D | SET 0,E | SET 0,H | SET 0,L | SET 0,(HL) | SET 0,A | SET 1,B | SET 1,C | SET 1,D | SET 1,E | SET 1,H | SET 1,L | SET 1,(HL) | SET 1,A |
| | D | SET 2,B | SET 2,C | SET 2,D | SET 2,E | SET 2,H | SET 2,L | SET 2,(HL) | SET 2,A | SET 3,B | SET 3,C | SET 3,D | SET 3,E | SET 3,H | SET 3,L | SET 3,(HL) | SET 3,A |
| | E | SET 4,B | SET 4,C | SET 4,D | SET 4,E | SET 4,H | SET 4,L | SET 4,(HL) | SET 4,A | SET 5,B | SET 5,C | SET 5,D | SET 5,E | SET 5,H | SET 5,L | SET 5,(HL) | SET 5,A |
| | F | SET 6,B | SET 6,C | SET 6,D | SET 6,E | SET 6,H | SET 6,L | SET 6,(HL) | SET 6,A | SET 7,B | SET 7,C | SET 7,D | SET 7,E | SET 7,H | SET 7,L | SET 7,(HL) | SET 7,A |

Notes: n = 8-bit data; Mmn = 16- or 24-bit addr or data; d = 8-bit two's-complement displacement.



Table 120.Op Code Map—Second Op Code After 0DDh

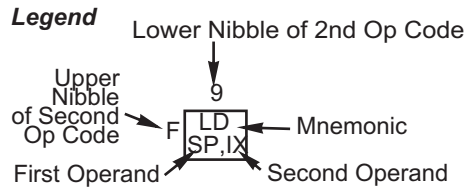

| | | Lower Nibble (Hex) | | | | | | | | | | | | | | | |
|--------------------|---|--------------------|---------------|--------------|--------------|-------------|--------------|---------------|---------------|----------|-----------|--------------|----------|---------------------------|------------|---------------|---------------|
| | | 0 | 1 | 2 | 3 | 4 | 5 | 6 | 7 | 8 | 9 | A | B | C | D | E | F |
| Upper Nibble (Hex) | 0 | | | | | | | | LD BC, (IX+d) | | ADD IX,BC | | | | | | LD (IX+d), BC |
| | 1 | | | | | | | | LD DE, (IX+d) | | ADD IX,DE | | | | | | LD (IX+d), DE |
| | 2 | | LD IX, Mmn | LD (Mmn), IX | INC IX | INC IXH | DEC IXH | LD IXH,n | LD HL, (IX+d) | | ADD IX,IX | LD IX, (Mmn) | DEC IX | INC IXL | DEC IXL | LD IXL,n | LD (IX+d), HL |
| | 3 | | LD IY, (IX+d) | | | INC (IX+d) | DEC (IX+d) | LD (IX+d),n | LD IX, (IX+d) | | ADD IX,SP | | | | | LD (IX+d), IY | LD (IX+d), IX |
| | 4 | | | | | LD B,IXH | LD B,IXL | LD B, (IX+d) | | | | | | LD C,IXH | LD C,IXL | LD C, (IX+d) | |
| | 5 | | | | | LD D,IXH | LD D,IXL | LD D, (IX+d) | | | | | | LD E,IXH | LD E,IXL | LD E, (IX+d) | |
| | 6 | LD IXH,B | LD IXH,C | LD IXH,D | LD IXH,E | LD IXH,IXH | LD IXH,IXL | LD H, (IX+d) | LD IXH,A | LD IXL,B | LD IXL,C | LD IXL,D | LD IXL,E | LD IXL,IXH | LD IXL,IXL | LD L, (IX+d) | LD IXL,A |
| | 7 | LD (IX+d), B | LD (IX+d), C | LD (IX+d), D | LD (IX+d), E | LD (IX+d),H | LD (IX+d), L | | LD (IX+d), A | | | | | LD A,IXH | LD A,IXL | LD A, (IX+d) | |
| | 8 | | | | | ADD A,IXH | ADD A,IXL | ADD A, (IX+d) | | | | | | ADC A,IXH | ADC A,IXL | ADC A, (IX+d) | |
| | 9 | | | | | SUB A,IXH | SUB A,IXL | SUB A, (IX+d) | | | | | | SBC A,IXH | SBC A,IXL | SBC A, (IX+d) | |
| | A | | | | | AND A,IXH | AND A,IXL | AND A, (IX+d) | | | | | | XOR A,IXH | XOR A,IXL | XOR A, (IX+d) | |
| | B | | | | | OR A,IXH | OR A,IXL | ORA, (IX+d) | | | | | | CP A,IXH | CP A,IXL | CP A, (IX+d) | |
| | C | | | | | | | | | | | | | Table 123 | | | |
| | D | | | | | | | | | | | | | | | | |
| | E | | POP IX | | EX (SP),IX | | PUSH IX | | | | | JP (IX) | | | | | |
| | F | | | | | | | | | | | LD SP,IX | | | | | |

Notes: n = 8-bit data; Mmn = 16- or 24-bit addr or data; d = 8-bit two's-complement displacement.



Table 121.Op Code Map—Second Op Code After 0EDh

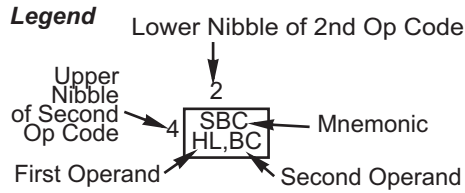

| | | Lower Nibble (Hex) | | | | | | | | | | | | | | | | |
|--------------------|---|--------------------|-------------|--------------|--------------|--------------|--------------|----------|-------------|-----------|------------|-----------|--------------|---------|---------|-------------|-------------|--|
| | | 0 | 1 | 2 | 3 | 4 | 5 | 6 | 7 | 8 | 9 | A | B | C | D | E | F | |
| Upper Nibble (Hex) | 0 | IN0 B,(n) | OUT0 (n),B | LEA BC, IX+d | LEA BC, IY+d | TST A,B | | | LD BC, (HL) | IN0 C,(n) | OUT0 (n),C | | | TST A,C | | | LD (HL), BC | |
| | 1 | IN0 D,(n) | OUT0 (n),D | LEA DE, IX+d | LEA DE, IY+d | TST A,D | | | LD DE, (HL) | IN0 E,(n) | OUT0 (n),E | | | TST A,E | | | LD(HL), DE | |
| | 2 | IN0 H,(n) | OUT0 (n),H | LEA HL, IX+d | LEA HL, IY+d | TST A,H | | | LD HL, (HL) | IN0 L,(n) | OUT0 (n),L | | | TST A,L | | | LD (HL), HL | |
| | 3 | | LD IY, (HL) | LEA IX, IX+d | LEA IY, IY+d | TST A,(HL) | | | LD IX, (HL) | IN0 A,(n) | OUT0 (n),A | | | TST A,A | | LD (HL), IY | LD (HL), IX | |
| | 4 | IN B,(BC) | OUT (BC),B | SBC HL,BC | LD (Mmn), BC | NEG | RETN | IM 0 | LD I,A | IN C,(C) | OUT (C),C | ADC HL,BC | LD BC, (Mmn) | MLT BC | RETI | | LD R,A | |
| | 5 | IN D,(BC) | OUT (BC),D | SBC HL,DE | LD (Mmn), DE | LEA IX, IY+d | LEA IY, IX+d | IM 1 | LD A,I | IN E,(C) | OUT (C),E | ADC HL,DE | LD DE, (Mmn) | MLT DE | | IM 2 | LD A,R | |
| | 6 | IBN H,(C) | OUT (BC),H | SBC HL,HL | LD (Mmn), HL | TST A,n | PEA IX+d | PEA IY+d | RRD | IN L,(C) | OUT (C),L | ADC HL,HL | LD HL, (Mmn) | MLT HL | LD MB,A | LD A,MB | RLD | |
| | 7 | | | SBC HL,SP | LD (Mmn), SP | TSTIO n | | SLP | | IN A,(C) | OUT (C),A | ADC HL,SP | LD SP, (Mmn) | MLT SP | STMIX | RSMIX | | |
| | 8 | | | INIM | OTIM | INI2 | | | | | | | INDM | OTDM | IND2 | | | |
| | 9 | | | INIMR | OTIMR | INI2R | | | | | | | INDMR | OTDMR | IND2R | | | |
| | A | LDI | CPI | INI | OUTI | OUTI2 | | | | LDD | CPD | IND | OUTD | OUTD2 | | | | |
| | B | LDIR | CPIR | INIR | OTIR | OTI2R | | | | LDDR | CPDR | INDR | OTDR | OTD2R | | | | |
| | C | | | INIRX | OTIRX | | | | | | | | INDRX | OTDRX | | | | |
| | D | | | | | | | | | | | | | | | | | |
| | E | | | | | | | | | | | | | | | | | |
| | F | | | | | | | | | | | | | | | | | |

Notes: n = 8-bit data; Mmn = 16- or 24-bit addr or data; d = 8-bit two's-complement displacement.



Table 122.Op Code Map—Second Op Code After 0FDh

Legend Lower Nibble of 2nd Op Code

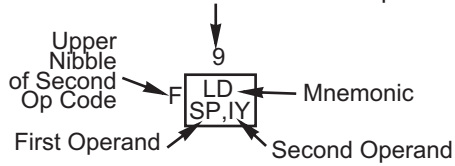

| | | Lower Nibble (Hex) | | | | | | | | | | | | | | | |
|--------------------|---|--------------------|---------------|-------------|-------------|-------------|-------------|---------------|---------------|----------|-----------|--------------|----------|---------------------------|------------|---------------|--------------|
| | | 0 | 1 | 2 | 3 | 4 | 5 | 6 | 7 | 8 | 9 | A | B | C | D | E | F |
| Upper Nibble (Hex) | 0 | | | | | | | | LD BC, (IY+d) | | ADD IY,BC | | | | | | LD (IY+d),BC |
| | 1 | | | | | | | | LD DE, (IY+d) | | ADD IY,DE | | | | | | LD (IY+d),DE |
| | 2 | | LD IY,Mmn | LD (Mmn),IY | INC IY | INC IYH | DEC IYH | LD IYH,n | LD HL, (IY+d) | | ADD IY,IY | LD IY, (Mmn) | DEC IY | INC IYL | DEC IYL | LD IYL,n | LD (IY+d),HL |
| | 3 | | LD IX, (IY+d) | | | INC (IY+d) | DEC (IY+d) | LD (IY+d),n | LD IY, (IY+d) | | ADD IY,SP | | | | | LD (IY+d),IX | LD (IY+d),IY |
| | 4 | | | | | LD B,IYH | LD B,IYL | LD B, (IY+d) | | | | | | LD C,IYH | LD C,IYL | LD C, (IY+d) | |
| | 5 | | | | | LD D,IYH | LD D,IYL | LD D, (IY+d) | | | | | | LD E,IYH | LD E,IYL | LD E, (IY+d) | |
| | 6 | LD IYH,B | LD IYH,C | LD IYH,D | LD IYH,E | LD IYH,IYH | LD IYH,IYL | LD H, (IY+d) | LD IYH,A | LD IYL,B | LD IYL,C | LD IYL,D | LD IYL,E | LD IYL,IYH | LD IYL,IYL | LD L, (IY+d) | LD IYL,A |
| | 7 | LD (IY+d),B | LD (IY+d),C | LD (IY+d),D | LD (IY+d),E | LD (IY+d),H | LD (IY+d),L | | LD (IY+d),A | | | | | LD A,IYH | LD A,IYL | LD A, (IY+d) | |
| | 8 | | | | | ADD A,IYH | ADD A,IYL | ADD A, (IY+d) | | | | | | ADC A,IYH | ADC A,IYL | ADC A, (IY+d) | |
| | 9 | | | | | SUB A,IYH | SUB A,IYL | SUB A, (IY+d) | | | | | | SBC A,IYH | SBC A,IYL | SBC A, (IY+d) | |
| | A | | | | | AND A,IYH | AND A,IYL | AND A, (IY+d) | | | | | | XOR A,IYH | XOR A,IYL | XOR A, (IY+d) | |
| | B | | | | | OR A,IYH | OR A,IYL | OR A, (IY+d) | | | | | | CP A,IYH | CP A,IYL | CP A, (IY+d) | |
| | C | | | | | | | | | | | | | Table 124 | | | |
| | D | | | | | | | | | | | | | | | | |
| | E | | POP IY | | EX (SP),IY | | PUSH IY | | | | | JP (IY) | | | | | |
| | F | | | | | | | | | | | LD SP,IY | | | | | |

Notes: n = 8-bit data; Mmn = 16- or 24-bit addr or data; d = 8-bit two's-complement displacement.



Table 123. Op Code Map—Fourth Byte After 0DDh, 0CBh, and dd

Legend

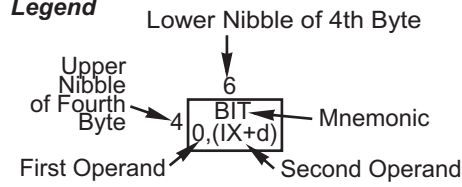

| | | Lower Nibble (Hex) | | | | | | | | | | | | | | | |
|--------------------|---|--------------------|---|---|---|---|---|------------------|---|---|---|---|---|---|---|------------------|---|
| | | 0 | 1 | 2 | 3 | 4 | 5 | 6 | 7 | 8 | 9 | A | B | C | D | E | F |
| Upper Nibble (Hex) | 0 | | | | | | | RLC (IX+d) | | | | | | | | RRC (IX+d) | |
| | 1 | | | | | | | RL (IX+d) | | | | | | | | RR (IX+d) | |
| | 2 | | | | | | | SLA (IX+d) | | | | | | | | SRA (IX+d) | |
| | 3 | | | | | | | | | | | | | | | SRL (IX+d) | |
| | 4 | | | | | | | BIT 0, (IX+d) | | | | | | | | BIT 1, (IX+d) | |
| | 5 | | | | | | | BIT 2, (IX+d) | | | | | | | | BIT 3, (IX+d) | |
| | 6 | | | | | | | BIT 4, (IX+d) | | | | | | | | BIT 5, (IX+d) | |
| | 7 | | | | | | | BIT 6, (IX+d) | | | | | | | | BIT 7, (IX+d) | |
| | 8 | | | | | | | RES 0, (IX+d) | | | | | | | | RES 1, (IX+d) | |
| | 9 | | | | | | | RES 2, (IX+d) | | | | | | | | RES 3, (IX+d) | |
| | A | | | | | | | RES 4, (IX+d) | | | | | | | | RES 5, (IX+d) | |
| | B | | | | | | | RES 6, (IX+d) | | | | | | | | RES 7, (IX+d) | |
| | C | | | | | | | SET 0, (IX+d) | | | | | | | | SET 1, (IX+d) | |
| | D | | | | | | | SET 2, (IX+d) | | | | | | | | SET 3, (IX+d) | |
| | E | | | | | | | SET 4, (IX+d) | | | | | | | | SET 5, (IX+d) | |
| | F | | | | | | | SET 6, (IX+d) | | | | | | | | SET 7, (IX+d) | |

Notes: d = 8-bit two's-complement displacement.



Table 124. Op Code Map—Fourth Byte After 0FDh, 0CBh, and dd*

Legend

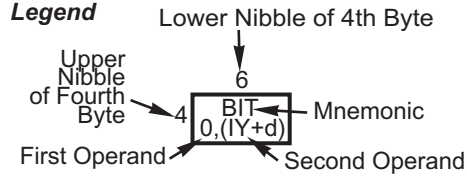

| | | Lower Nibble (Hex) | | | | | | | | | | | | | | | |
|--------------------|---|--------------------|---|---|---|---|---|------------------|---|---|---|---|---|---|---|------------------|---|
| | | 0 | 1 | 2 | 3 | 4 | 5 | 6 | 7 | 8 | 9 | A | B | C | D | E | F |
| Upper Nibble (Hex) | 0 | | | | | | | RLC (IY+d) | | | | | | | | RRC (IY+d) | |
| | 1 | | | | | | | RL (IY+d) | | | | | | | | RR (IY+d) | |
| | 2 | | | | | | | SLA (IY+d) | | | | | | | | SRA (IY+d) | |
| | 3 | | | | | | | | | | | | | | | SRL (IY+d) | |
| | 4 | | | | | | | BIT 0, (IY+d) | | | | | | | | BIT 1, (IY+d) | |
| | 5 | | | | | | | BIT 2, (IY+d) | | | | | | | | BIT 3, (IY+d) | |
| | 6 | | | | | | | BIT 4, (IY+d) | | | | | | | | BIT 5, (IY+d) | |
| | 7 | | | | | | | BIT 6, (IY+d) | | | | | | | | BIT 7, (IY+d) | |
| | 8 | | | | | | | RES 0, (IY+d) | | | | | | | | RES 1, (IY+d) | |
| | 9 | | | | | | | RES 2, (IY+d) | | | | | | | | RES 3, (IY+d) | |
| | A | | | | | | | RES 4, (IY+d) | | | | | | | | RES 5, (IY+d) | |
| | B | | | | | | | RES 6, (IY+d) | | | | | | | | RES 7, (IY+d) | |
| | C | | | | | | | SET 0, (IY+d) | | | | | | | | SET 1, (IY+d) | |
| | D | | | | | | | SET 2, (IY+d) | | | | | | | | SET 3, (IY+d) | |
| | E | | | | | | | SET 4, (IY+d) | | | | | | | | SET 5, (IY+d) | |
| | F | | | | | | | SET 6, (IY+d) | | | | | | | | SET 7, (IY+d) | |

Notes: d = 8-bit two's-complement displacement.

On-Chip Oscillators

The eZ80L92 features two on-chip oscillators for use with an external crystal. The primary oscillator generates the system clock for the internal CPU and the majority of the on-chip peripherals. Alternatively, the X_{IN} input pin can also accept a CMOS-level clock input signal. If an external clock generator is used, the X_{OUT} pin should be left unconnected. The secondary oscillator can drive a 32KHz crystal to generate the time-base for the Real-Time Clock.

20 MHz Primary Crystal Oscillator Operation

Figure 44 illustrates a recommended configuration for connection with an external 20MHz, fundamental-mode, parallel-resonant crystal. Recommended crystal specifications are provided in Table 125. Resistor R_1 limits total power dissipation by the crystal. Printed circuit board layout should add no more than 4pF of stray capacitance to either the X_{IN} or X_{OUT} pins. If oscillation does not occur, reduce the values of capacitors C_1 and C_2 to decrease loading.

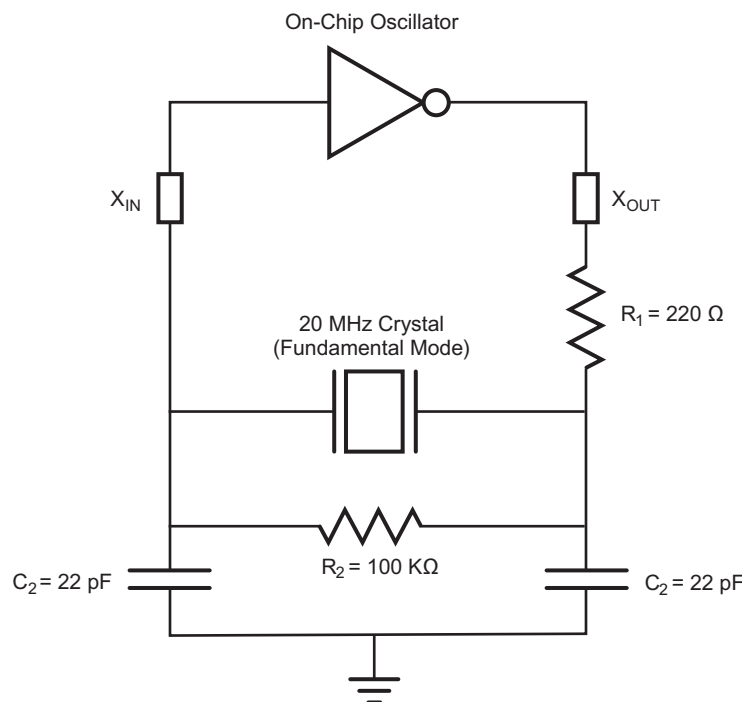

Figure 44. Recommended Crystal Oscillator Configuration (20MHz operation)



Table 125. Recommended Crystal Oscillator Specifications (20MHz Operation)

| Parameter | Value | Units | Comments |
|-----------------------------|-------------|----------|----------|
| Frequency | 20 | MHz | |
| Resonance | Parallel | | |
| Mode | Fundamental | | |
| Series Resistance (R_S) | 25 | Ω | Maximum |
| Load Capacitance (C_L) | 20 | pF | Maximum |
| Shunt Capacitance (C_0) | 7 | pF | Maximum |
| Drive Level | 1 | mW | Maximum |

50MHz Primary Crystal Oscillator Operation

Figure 45 illustrates a recommended configuration for connection with an external 50MHz, third-overtone, parallel-resonant crystal. Recommended crystal specifications are provided in Table 126. Printed circuit board layout should add no more than 4pF of stray capacitance to either the X_{IN} or X_{OUT} pins. If oscillation does not occur, the user should try removing C1 for testing and decreasing the value of C_2 by the estimated stray capacitance to decrease loading.

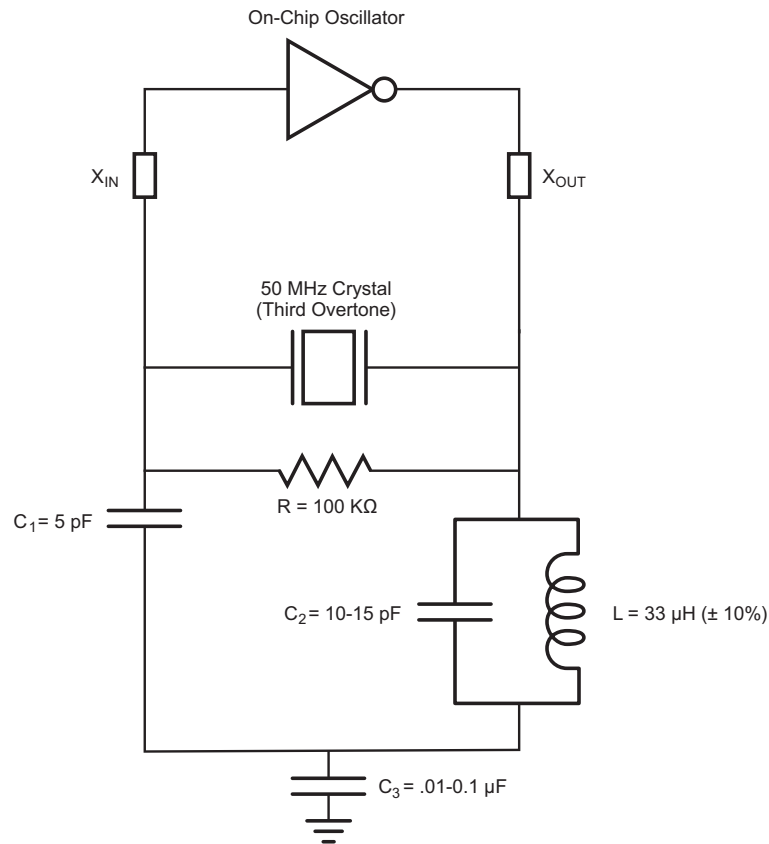

Figure 45. Recommended Crystal Oscillator Configuration (50MHz operation)

Table 126. Recommended Crystal Oscillator Specifications (50MHz Operation)

| Parameter | Value | Units | Comments |
|-----------------------------|--------------|----------|----------|
| Frequency | 50 | MHz | |
| Resonance | Parallel | | |
| Mode | 3rd Overtone | | |
| Series Resistance (R_S) | 65 | Ω | Maximum |
| Load Capacitance (C_L) | 20 | pF | Maximum |
| Shunt Capacitance (C_0) | 7 | pF | Maximum |
| Drive Level | 100 | μW | Maximum |

32 KHz Real-Time Clock Crystal Oscillator Operation

Figure 46 illustrates a recommended configuration for connecting the Real-Time Clock oscillator with an external 32KHz, fundamental-mode, parallel-resonant crystal. The recommended crystal specifications are provided in Table 127. A printed circuit board layout should add no more than 4 pF of stray capacitance to either the RTC_X_{IN} or RTC_X_{OUT} pins. If oscillation does not occur, reduce the values of capacitors C₁ and C₂ to decrease loading.

An on-chip MOS resistor sets the crystal drive current limit. This configuration does not require an external bias resistor across the crystal. An on-chip MOS resistor provides the biasing.

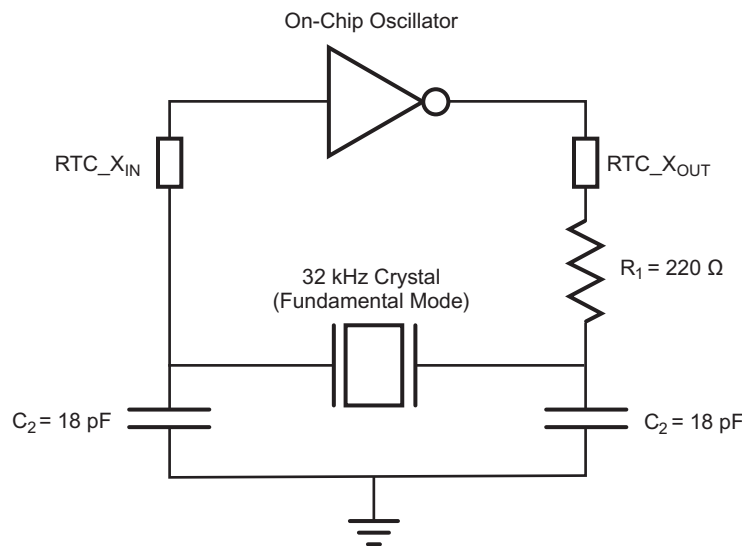

Figure 46. Recommended Crystal Oscillator Configuration (32KHz operation)

Table 127. Recommended Crystal Oscillator Specifications (32KHz Operation)

| Parameter | Value | Units | Comments |
|-------------------------------------|-------------|-------|----------|
| Frequency | 32 | KHz | 32768 Hz |
| Resonance | Parallel | | |
| Mode | Fundamental | | |
| Series Resistance (R _S) | 40 | kΩ | Maximum |

**Table 127. Recommended Crystal Oscillator Specifications (32KHz Operation) (Continued)**

| Parameter | Value | Units | Comments |
|-----------------------------|--------------|--------------|-----------------|
| Load Capacitance (C_L) | 12.5 | pF | Maximum |
| Shunt Capacitance (C_0) | 3 | pF | Maximum |
| Drive Level | 1 | μ W | Maximum |



Electrical Characteristics

Absolute Maximum Ratings

Stresses greater than those listed in Table 128 may cause permanent damage to the device. These ratings are stress ratings only. Operation of the device at any condition outside those indicated in the operational sections of these specifications is not implied. Exposure to absolute maximum rating conditions for extended periods may affect device reliability. For improved reliability, unused inputs should be tied to one of the supply voltages (V_{DD} or V_{SS}).

Table 128. Absolute Maximum Ratings

| Parameter | Min | Max | Units | Notes |
|---|------|------|---------|-------|
| Ambient temperature under bias (°C) | -40 | +105 | C | 1 |
| Storage temperature (°C) | -65 | +150 | C | |
| Voltage on any pin with respect to V_{SS} | -0.3 | +6.0 | V | 2 |
| Voltage on V_{DD} pin with respect to V_{SS} | -0.3 | +6.0 | V | |
| Total power dissipation | | 520 | mW | |
| Maximum current out of V_{SS} | | 145 | mA | |
| Maximum current into V_{DD} | | 145 | mA | |
| Maximum current on input and/or inactive output pin | -15 | +15 | μ A | |
| Maximum output current from active output pin | -8 | +8 | mA | |

Notes:

1. Operating temperature is specified in DC Characteristics.
2. This voltage applies to all pins except where noted otherwise.



DC Characteristics

Table 129 lists the DC characteristics of the eZ80L92. Figures 47 and 48 plot supply current values against CPU frequency and wait states.

- **Note:** All data is preliminary and subject to change following completion of production characterization.

Table 129. DC Characteristics

| Symbol | Parameter | $T_A = 0^\circ\text{C to }70^\circ\text{C}$ | | $T_A = -40^\circ\text{C to }105^\circ\text{C}$ | | Units | Conditions |
|--------------------------------|--------------------------------------|---|-----|--|---------------|-------------------------|---|
| | | Min | Max | Min | Max | | |
| V_{DD} | Supply Voltage | 3.0 | 3.6 | 3.0 | 3.6 | V | |
| V_{IL} | Low Level Input Voltage | -0.3 | 0.8 | -0.3 | 0.8 | V | |
| V_{IH} | High Level Input Voltage | $0.7 \times V_{DD}$ | 5.5 | $0.7 \times V_{DD}$ | 5.5 | V | |
| V_{OL} | Low Level Output Voltage | | 0.4 | | 0.4 | V | $V_{DD} = 3.0\text{V};$ $I_{OL} = 1\text{mA}$ |
| V_{OH} | High Level Output Voltage | 2.4 | | 2.4 | | V | $V_{DD} = 3.0\text{V};$ $I_{OH} = -1\text{mA}$ |
| I_{IL} | Input Leakage Current | -10 | +10 | -10 | +10 | μA | $V_{DD} = 3.6\text{V};$ $V_{IN} = V_{DD}$ or V_{SS} ¹ |
| I_{TL} | Tristate Leakage Current | -10 | +10 | -10 | +10 | μA | $V_{DD} = 3.6\text{V}$ |
| I_{DD} | Power Dissipation (normal operation) | | 100 | | 100 | mA | F = 20MHz |
| | | | 145 | | 145 | mA | F = 50MHz |
| | Power Dissipation (HALT mode) | | 10 | | 10 | mA | F = 20MHz |
| | | | 20 | | 20 | mA | F = 50MHz |
| Power Dissipation (SLEEP mode) | | 10 | | 25 | μA | Internal clocks stopped | |
| RTC_V_{DD} | RTC Supply Voltage | 3.0 | 3.6 | 3.0 | 3.6 | V | |
| I_{RTC} | RTC Supply Current | 2.5 typical | 10 | 2.5 typical | 10 | μA | Supply current into RTC_V_{DD} |

Note: ¹This condition excludes all pins with on-chip pull-ups when driven Low.

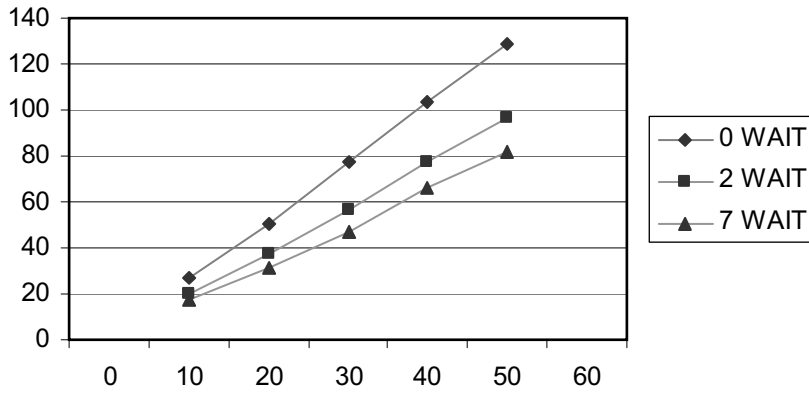

Figure 47. I_{CC} vs. Frequency (Typical @ 3.3V, 25°C)

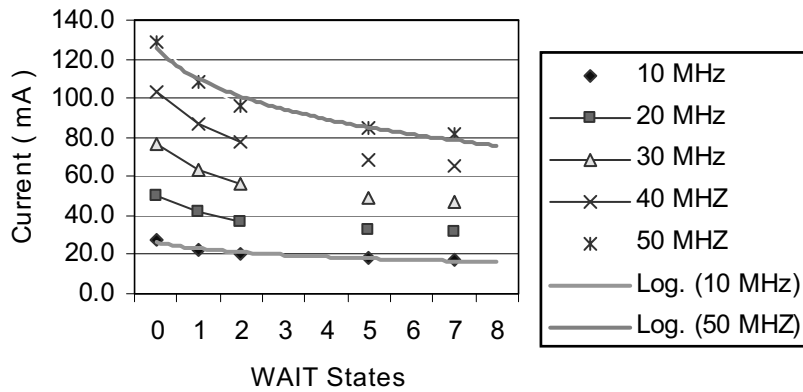

Figure 48. I_{CC} vs. WAIT (Typical @ 3.3V, 25°C)



AC Characteristics

The section provides information on the AC characteristics and timing of the eZ80L92. All AC timing information assumes a standard load of 50pF on all outputs. See Table 130.

- **Note:** All data is preliminary and subject to change following completion of production characterization.

Table 130. AC Characteristics

| Symbol | Parameter | $T_A = 0^\circ\text{C to }70^\circ\text{C}$ | | $T_A = -40^\circ\text{C to }105^\circ\text{C}$ | | Units | Conditions |
|------------|-------------------------|---|-----|--|-----|-------|--|
| | | Min | Max | Min | Max | | |
| T_{XIN} | System Clock Cycle Time | 20 | | 20 | | ns | $V_{DD} = 3.0 - 3.6\text{V}$ |
| T_{XINH} | System Clock High Time | | 10 | | 10 | ns | $V_{DD} = 3.0 - 3.6\text{V};$ $T_{CLK} = 50\text{ns}$ |
| T_{XINL} | System Clock Low Time | | 10 | | 10 | ns | $V_{DD} = 3.0 - 3.6\text{V};$ $T_{CLK} = 50\text{ns}$ |
| T_{XINR} | System Clock Rise Time | | 3 | | 3 | ns | $V_{DD} = 3.0 - 3.6\text{V};$ $T_{CLK} = 50\text{ns}$ |
| T_{XINF} | System Clock Fall Time | | 3 | | 3 | ns | $V_{DD} = 3.0 - 3.6\text{V};$ $T_{CLK} = 50\text{ns}$ |

External Memory Read Timing

Figure 49 and Table 131 diagram the timing for external READs.

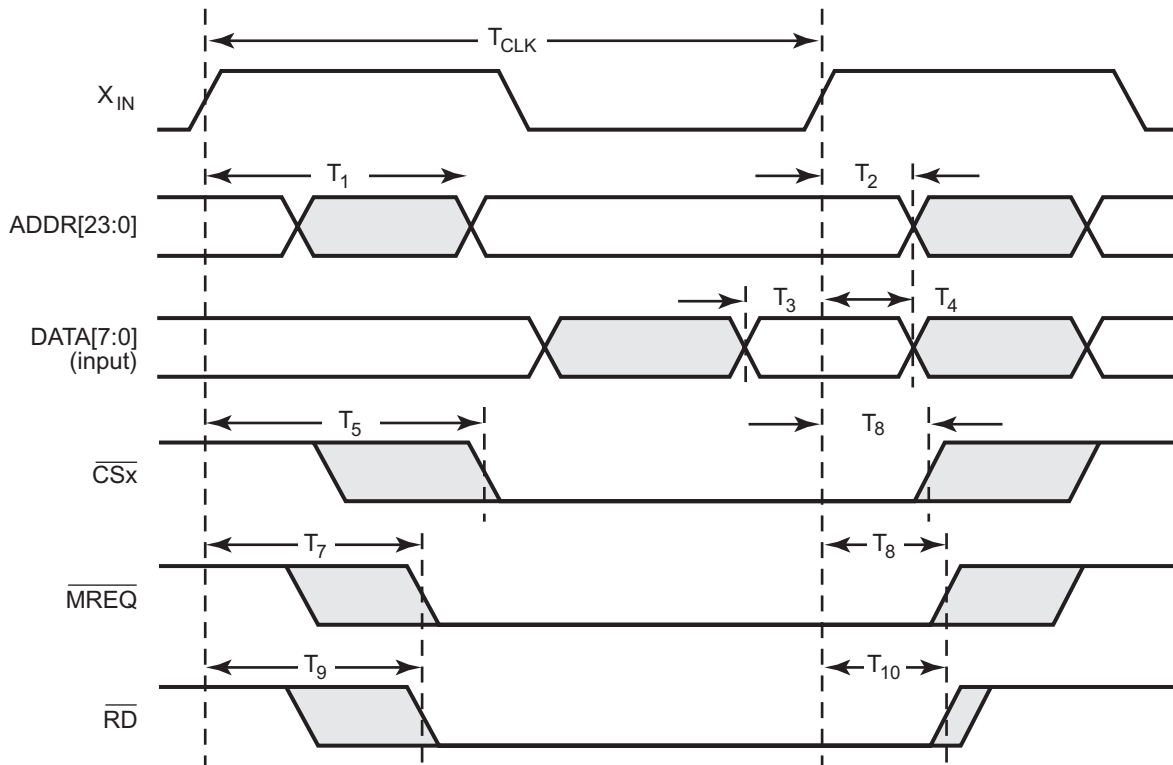

Figure 49. External Memory Read Timing

Table 131. External Read Timing

| Parameter | Description | 20MHz (ns) | | 50MHz (ns) | |
|----------------|--|------------|------|------------|------|
| | | Min. | Max. | Min. | Max. |
| T ₁ | Clock Rise to ADDR Valid Delay | — | 10.2 | — | 10.2 |
| T ₂ | Clock Rise to ADDR Hold Time | 2.4 | — | 2.4 | — |
| T ₃ | Input DATA Valid to Clock Rise Setup Time | 1.0 | — | 1.0 | — |
| T ₄ | DATA Hold Time from Clock Rise | 2.4 | — | 2.4 | — |
| T ₅ | Clock Rise to $\overline{\text{CSx}}$ Assertion Delay | 3.2 | 10.3 | 3.2 | 10.3 |
| T ₆ | Clock Rise to $\overline{\text{CSx}}$ Deassertion Delay | 2.9 | 9.7 | 2.9 | 9.7 |
| T ₇ | Clock Rise to $\overline{\text{MREQ}}$ Assertion Delay | 2.8 | 9.6 | 2.8 | 9.6 |
| T ₈ | Clock Rise to $\overline{\text{MREQ}}$ Deassertion Delay | 2.6 | 6.9 | 2.6 | 6.9 |



Table 131. External Read Timing (Continued)

| Parameter | Description | 20 MHz (ns) | | 50 MHz (ns) | |
|-----------------|--|-------------|------|-------------|------|
| | | Min. | Max. | Min. | Max. |
| T ₉ | Clock Rise to $\overline{\text{RD}}$ Assertion Delay | 3.0 | 9.8 | 3.0 | 9.8 |
| T ₁₀ | Clock Rise to $\overline{\text{RD}}$ Deassertion Delay | 2.6 | 7.1 | 2.6 | 7.1 |

External Memory Write Timing

Figure 50 and Table 132 diagram the timing for external writes.

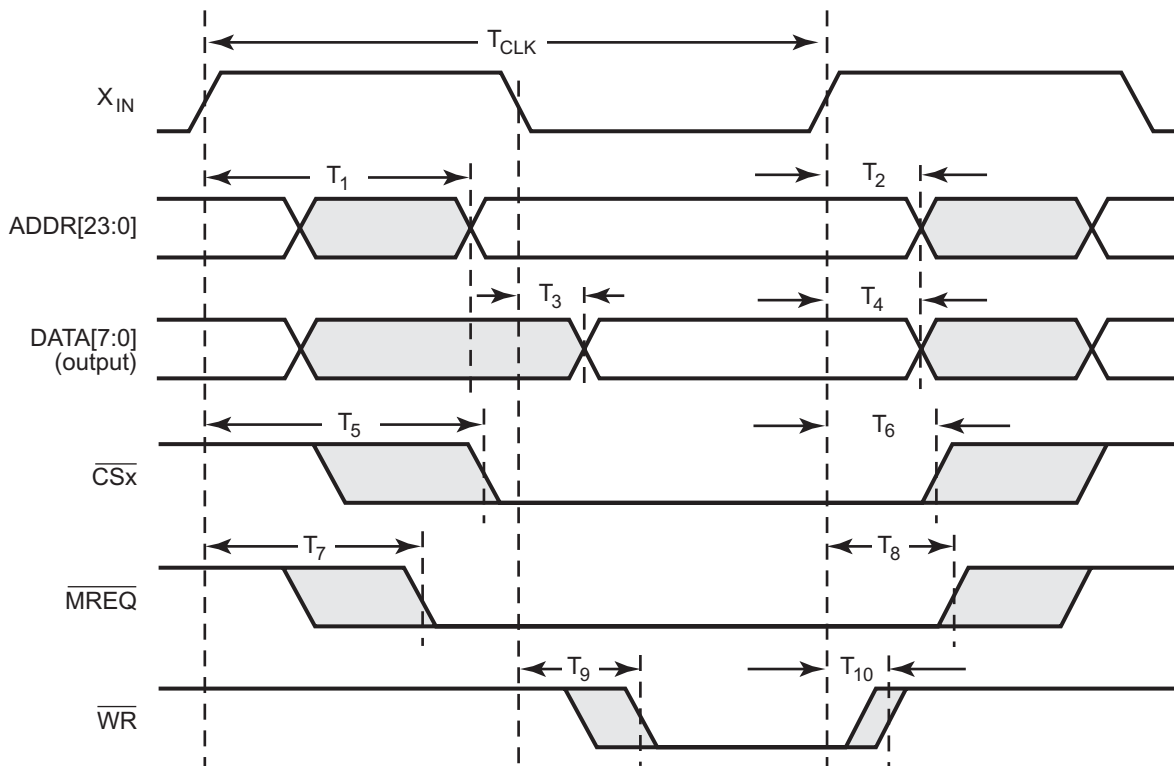

Figure 50. External Memory Write Timing



Table 132. External Write Timing

| Parameter | Description | 20 MHz (ns) | | 50 MHz (ns) | |
|-----------------|--|-------------|------|-------------|------|
| | | Min. | Max. | Min. | Max. |
| T ₁ | Clock Rise to ADDR Valid Delay | — | 10.2 | — | 10.2 |
| T ₂ | Clock Rise to ADDR Hold Time | 2.4 | — | 2.4 | — |
| T ₃ | Clock Fall to Output DATA Valid Delay | — | 6 | — | 6 |
| T ₄ | DATA Hold Time from Clock Rise | 2.4 | — | 2.4 | — |
| T ₅ | Clock Rise to $\overline{\text{CSx}}$ Assertion Delay | 3.2 | 10.3 | 3.2 | 10.3 |
| T ₆ | Clock Rise to $\overline{\text{CSx}}$ Deassertion Delay | 2.9 | 9.7 | 2.9 | 9.7 |
| T ₇ | Clock Rise to $\overline{\text{MREQ}}$ Assertion Delay | 2.8 | 9.6 | 2.8 | 9.6 |
| T ₈ | Clock Rise to $\overline{\text{MREQ}}$ Deassertion Delay | 2.6 | 6.9 | 2.6 | 6.9 |
| T ₉ | Clock Fall to $\overline{\text{WR}}$ Assertion Delay | 1.5 | 5.0 | 1.5 | 5.0 |
| T ₁₀ | Clock Rise to $\overline{\text{WR}}$ Deassertion Delay* | 1.4 | 3.6 | 1.4 | 3.6 |

Note: *At the conclusion of a write cycle, deassertion of $\overline{\text{WR}}$ always occurs before any change to ADDR, DATA, $\overline{\text{CSx}}$, or MREQ. In certain applications, the deassertion of WR can be concurrent with ADDR, DATA, $\overline{\text{CSx}}$, or MREQ when buffering is used off-chip.

External I/O Read Timing

Figure 51 and Table 133 diagram the timing for external I/O Reads.

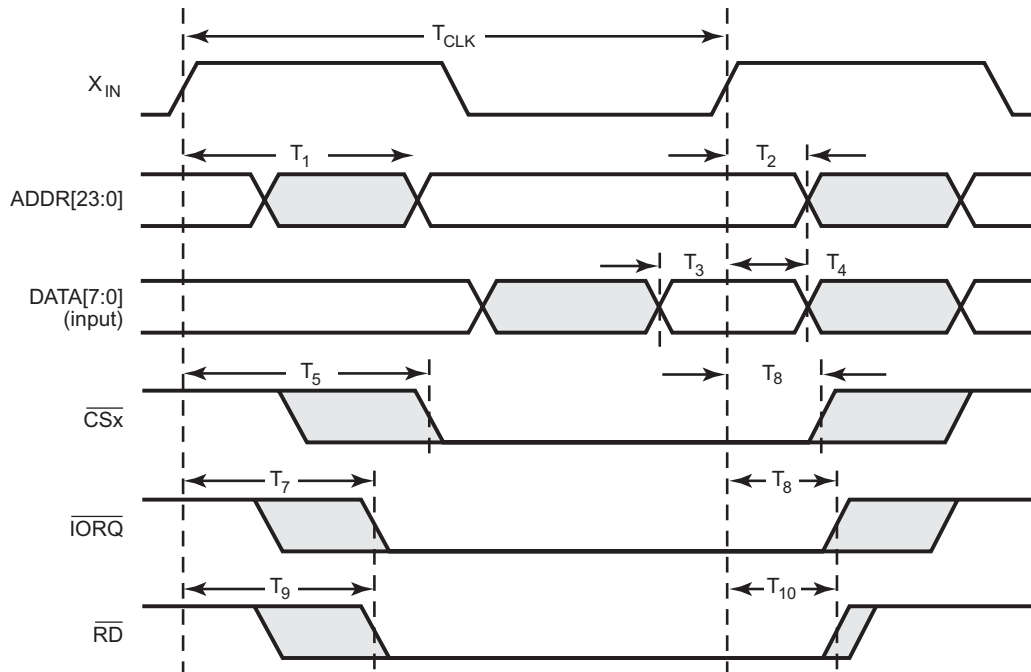

Figure 51. External I/O Read Timing

Table 133. External I/O Read Timing

| Parameter | Abbreviation | 20MHz (ns) | | 50MHz (ns) | |
|----------------|---|------------|------|------------|------|
| | | Min | Max | Min. | Max. |
| T ₁ | Clock Rise to ADDR Valid Delay | — | 6.9 | — | 6.9 |
| T ₂ | Clock Rise to ADDR Hold Time | 2.2 | — | 2.2 | — |
| T ₃ | Input DATA Valid to Clock Rise Setup Time | 0.4 | — | 0.4 | — |
| T ₄ | Clock Rise to DATA Hold Time | 1.3 | — | 1.3 | — |
| T ₅ | Clock Rise to CS _x Assertion Delay | 2.6 | 10.8 | 2.6 | 10.8 |
| T ₆ | Clock Rise to CS _x Deassertion Delay | 2.4 | 8.8 | 2.4 | 8.8 |
| T ₇ | Clock Rise to IORQ Assertion Delay | 2.6 | 7.0 | 2.6 | 7.0 |
| T ₈ | Clock Rise to IORQ Deassertion Delay | 2.3 | 6.3 | 2.3 | 6.3 |



Table 133. External I/O Read Timing (Continued)

| Parameter | Abbreviation | 20 MHz (ns) | | 50 MHz (ns) | |
|-----------------|--|-------------|-----|-------------|------|
| | | Min | Max | Min. | Max. |
| T ₉ | Clock Rise to $\overline{\text{RD}}$ Assertion Delay | 2.7 | 7.0 | 2.7 | 7.0 |
| T ₁₀ | Clock Rise to $\overline{\text{RD}}$ Deassertion Delay | 2.4 | 6.3 | 2.4 | 6.3 |

External I/O Write Timing

Figure 52 and Table 134 diagram the timing for external I/O writes.

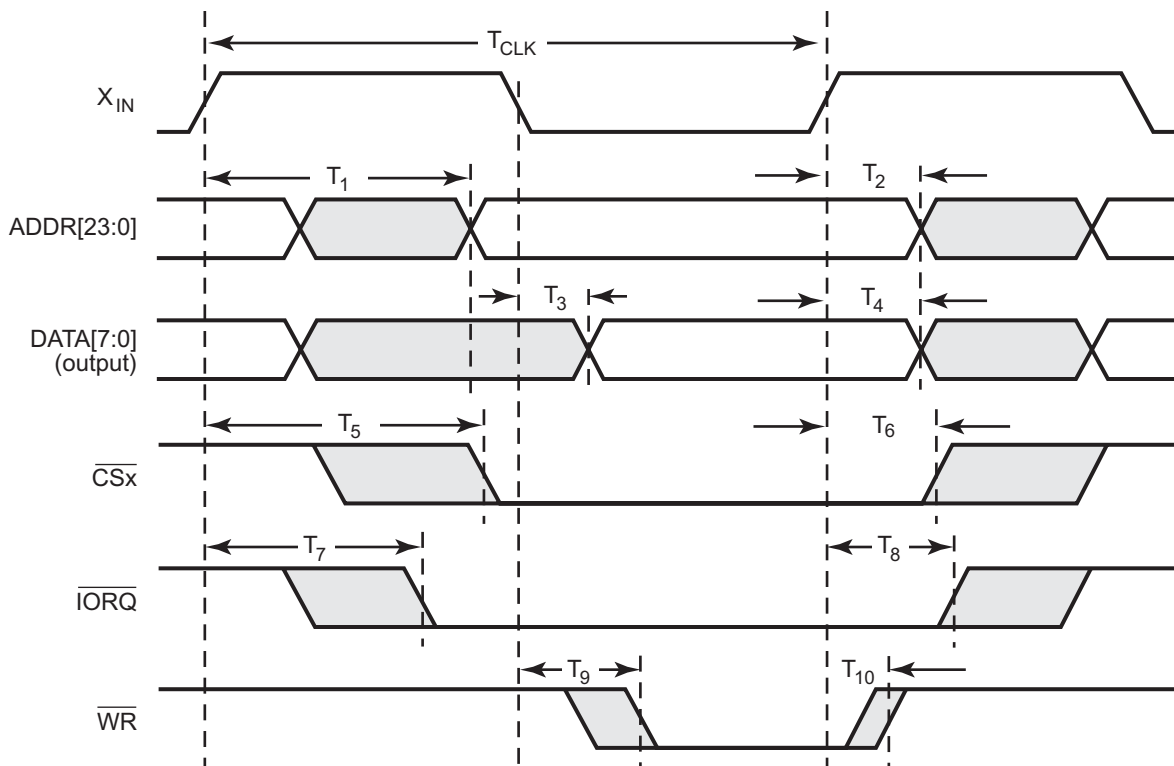

Figure 52. External I/O Write Timing



Table 134. External I/O Write Timing

| Parameter | Abbreviation | 20MHz (ns) | | 50MHz (ns) | |
|-----------------|---------------------------------------|------------|------|------------|------|
| | | Min | Max | Min. | Max. |
| T ₁ | Clock Rise to ADDR Valid Delay | — | 7.7 | — | 7.7 |
| T ₂ | Clock Rise to ADDR Hold Time | 2.2 | — | 2.2 | — |
| T ₃ | Clock Fall to Output DATA Valid Delay | — | 6 | — | 6 |
| T ₄ | Clock Rise to DATA Hold Time | 2.3 | — | 2.3 | — |
| T ₅ | Clock Rise to CSx Assertion Delay | 2.6 | 10.8 | 2.6 | 10.8 |
| T ₆ | Clock Rise to CSx Deassertion Delay | 2.4 | 8.8 | 2.4 | 8.8 |
| T ₇ | Clock Rise to IORQ Assertion Delay | 2.6 | 7.0 | 2.6 | 7.0 |
| T ₈ | Clock Rise to IORQ Deassertion Delay | 2.3 | 6.3 | 2.3 | 6.3 |
| T ₉ | Clock Fall to WR Assertion Delay | 1.8 | 4.5 | 1.8 | 4.5 |
| T ₁₀ | Clock Rise to WR Deassertion Delay* | 1.6 | 4.4 | 1.6 | 4.4 |
| | WR Deassertion to ADDR Hold Time | 0.4 | — | 0.4 | — |
| | WR Deassertion to DATA Hold Time | 0.5 | — | 0.5 | — |
| | WR Deassertion to CSx Hold Time | 1.2 | — | 1.2 | — |
| | WR Deassertion to IORQ Hold Time | 0.5 | — | 0.5 | — |

Note: *At the conclusion of a Write cycle, deassertion of WR always occurs before any change to ADDR, DATA, CSx, or IORQ. In certain applications, the deassertion of WR can be concurrent with ADDR, DATA, CSx, or MREQ when buffering is used off-chip.



Wait State Timing for Read Operations

Figure 53 illustrates the extension of the memory access signals using a single WAIT state for a READ operation. This WAIT state is generated by setting CS_WAIT to 001 in the Chip Select Control Register.

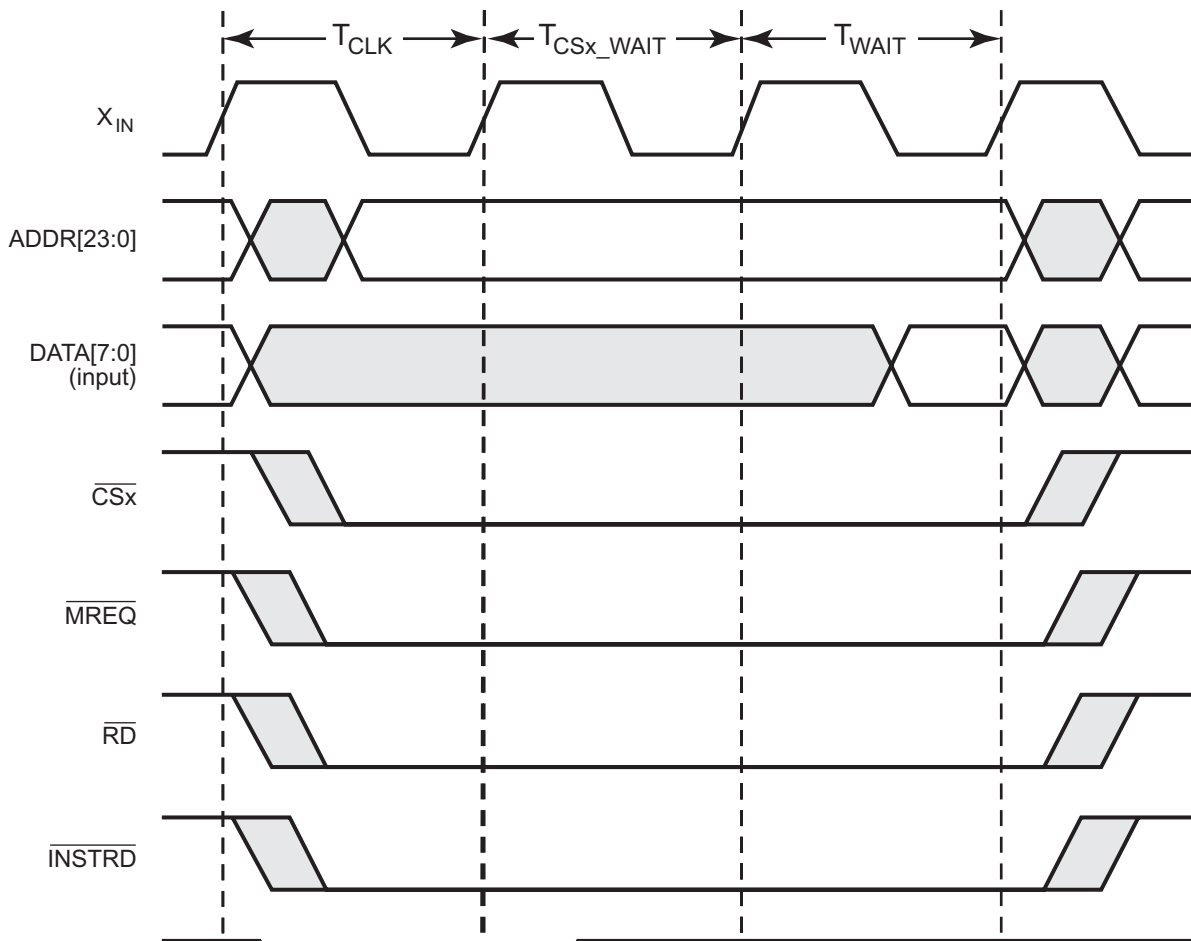

Figure 53. Wait State Timing for Read Operations

Wait State Timing for Write Operations

Figure 54 illustrates the extension of the memory access signals using a single WAIT state for a WRITE operation. This WAIT state is generated by setting CS_WAIT to 001 in the Chip Select Control Register.

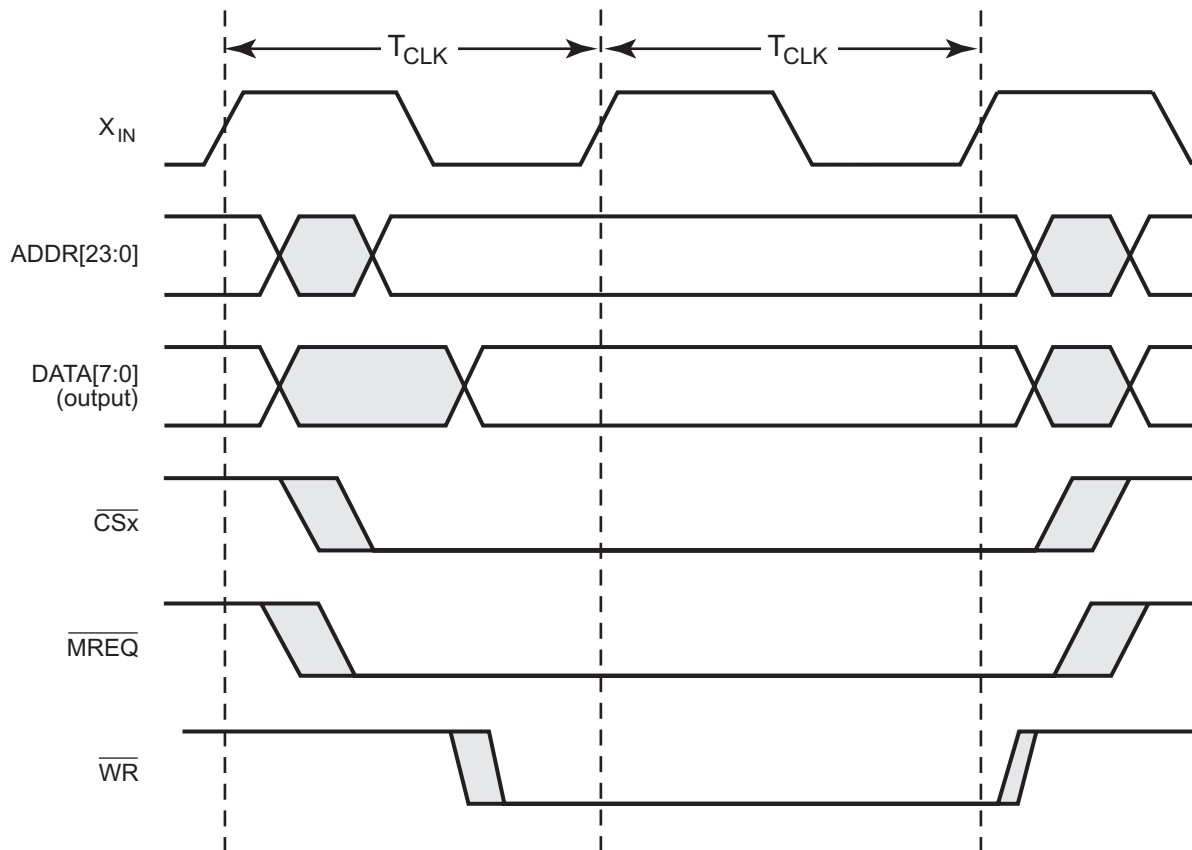

Figure 54. Wait State Timing for Write Operations



General Purpose I/O Port Input Sample Timing

Figure 55 illustrates timing of the GPIO input sampling. The input value on a GPIO port pin is sampled on the rising edge of the system clock. The port value is then available to the CPU on the second rising clock edge following the change of the port value.

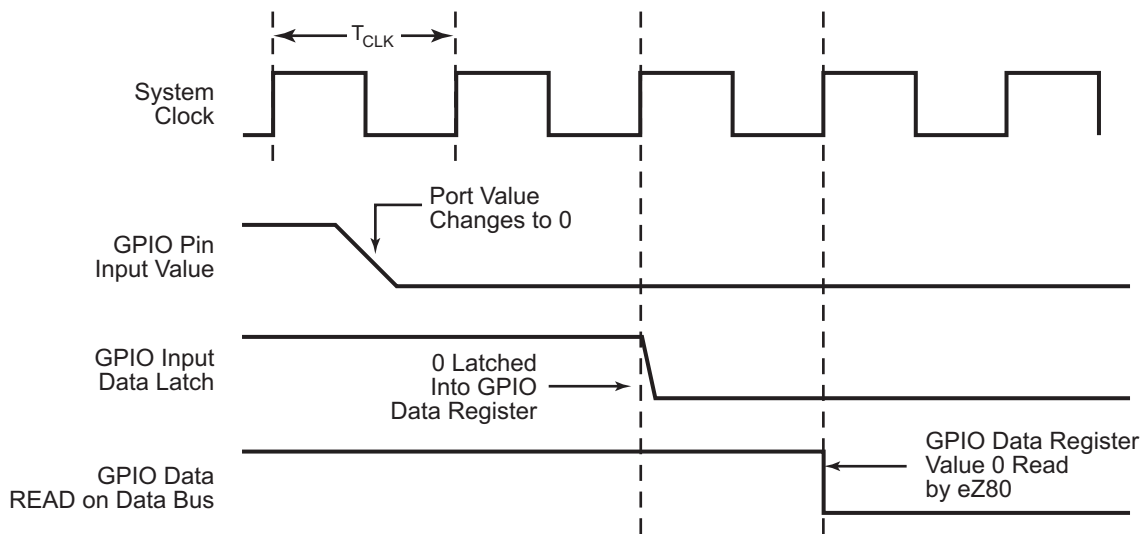

Figure 55. Port Input Sample Timing

General Purpose I/O Port Output Timing

Figure 56 and Table 135 provide timing information for GPIO port pins.

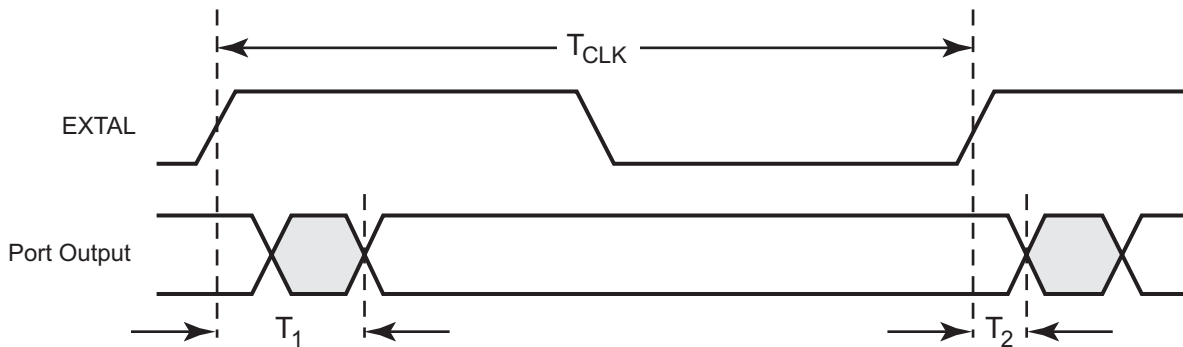

Figure 56. GPIO Port Output Timing



Table 135. GPIO Port Output Timing

| Parameter | Abbreviation | 20MHz (ns) | | 50MHz (ns) | |
|----------------|---------------------------------------|------------|-----|------------|-----|
| | | Min | Max | Min | Max |
| T ₁ | Clock Rise to Port Output Valid Delay | — | 9.3 | — | 9.3 |
| T ₂ | Clock Rise to Port Output Hold Time | 2.0 | — | 2.0 | — |

External Bus Acknowledge Timing

Table 136 provides information on the bus acknowledge timing.

Table 136. Bus Acknowledge Timing

| Parameter | Abbreviation | 20MHz (ns) | | 50MHz (ns) | |
|----------------|---|------------|-----|------------|-----|
| | | Min | Max | Min | Max |
| T ₁ | Clock Rise to <u>BUSACK</u> Assertion Delay | 2.8 | 9.3 | 2.8 | 9.3 |
| T ₂ | Clock Rise to <u>BUSACK</u> Deassertion Delay | 2.5 | 6.5 | 2.5 | 6.5 |

External System Clock Driver (PHI) Timing

Table 137 provides timing information for the PHI pin. The PHI pin allows external peripherals to synchronize with the internal system clock driver on the eZ80L92.

Table 137. PHI System Clock Timing

| Parameter | Abbreviation | 20MHz (ns) | | 50MHz (ns) | |
|----------------|------------------------|------------|-----|------------|-----|
| | | Min | Max | Min | Max |
| T ₁ | Clock Rise to PHI Rise | 1.6 | 4.6 | 1.6 | 4.6 |
| T ₂ | Clock Fall to PHI Fall | 1.8 | 4.3 | 1.8 | 4.3 |



Packaging

Figure 57 illustrates the 100-pin LQFP (low-profile quad flat pack) package for the eZ80L92 devices.

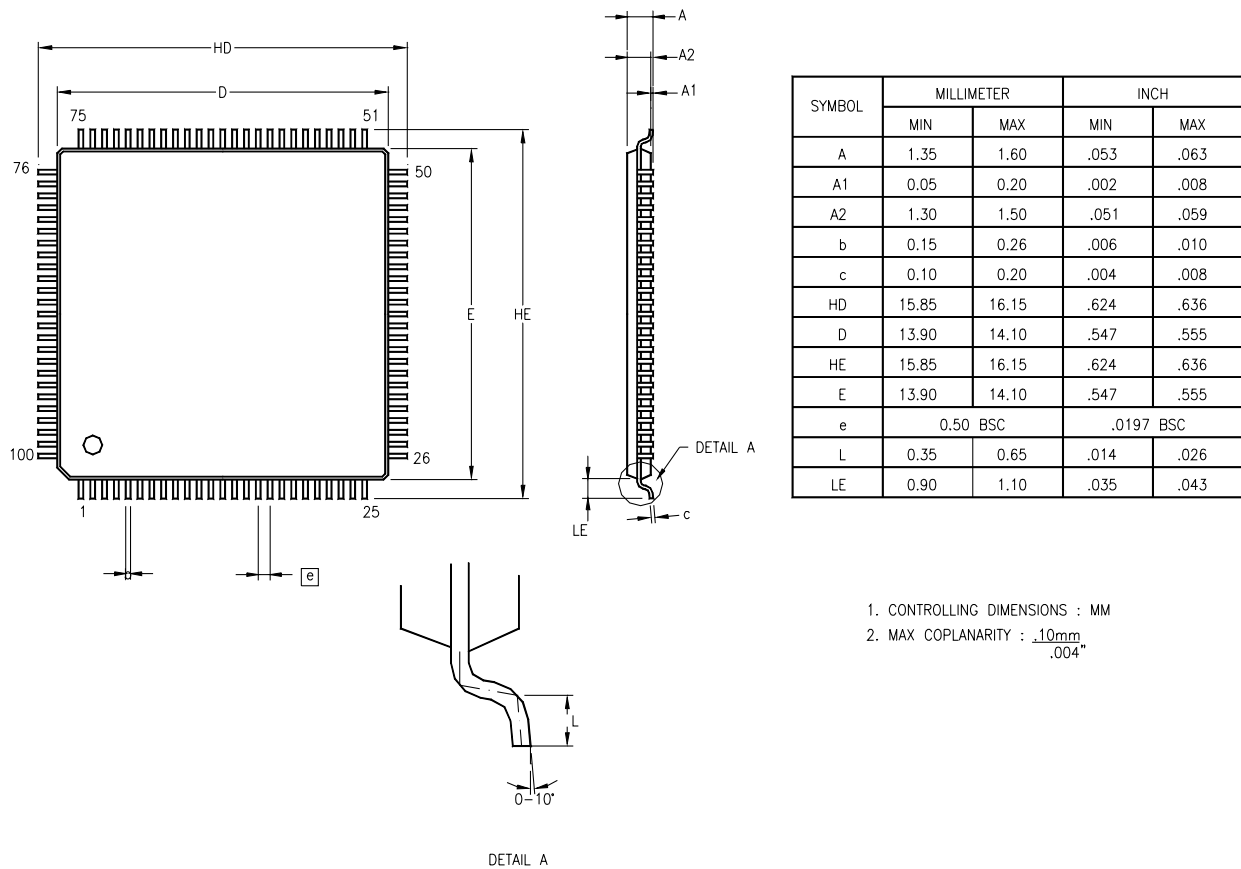

Figure 57. 100-Lead Plastic Low-Profile Quad Flat Package (LQFP)



Ordering Information

Table 138 provides a part number, a product specification index code, and a brief description of each eZ80L92 part.

Table 138. Ordering Information

| Part | PSI | Description |
|---------|----------------|--|
| eZ80L92 | eZ80L92AZ020SC | 100-pin LQFP, 20 MHz, Standard Temperature |
| eZ80L92 | eZ80L92AZ020EC | 100-pin LQFP, 20 MHz, Extended Temperature |
| eZ80L92 | eZ80L92AZ050SC | 100-pin LQFP, 50 MHz, Standard Temperature |
| eZ80L92 | eZ80L92AZ050EC | 100-pin LQFP, 50 MHz, Extended Temperature |

Navigate your browser to ZiLOG's website to order the [eZ80L92](#) MPU. Or, contact your local [ZiLOG Sales Office](#) to order these devices. ZiLOG provides additional assistance on its [Customer Service](#) page, and is also here to help with technical support issues.

For ZiLOG's valuable [software development tools](#) and [downloadable software](#), visit the [ZiLOG website](#).

Part Number Description

ZiLOG part numbers consist of a number of components, as indicated in the following examples:

| ZiLOG Base Products | |
|---------------------|-----------------------------|
| eZ80 | ZiLOG eZ80 [®] CPU |
| L92 | Product Number |
| AZ | Package |
| 050 | Speed |
| S or E | Temperature |
| C | Environmental Flow |



| | |
|-----------------------------|----------------------------------|
| Package | AZ = LQFP (also called the VQFP) |
| Speed | 050 = 50 MHz |
| Standard Temperature | S = 0°C to +70°C |
| Extended Temperature | E = -40°C to +105°C |
| Environmental Flow | C = Plastic Standard |

Example: Part number eZ80L92AZ020SC is an eZ80[®] CPU product in a LQFP package, operating with a 20-MHz external clock frequency over a 0°C to +70°C temperature range and built using the Plastic Standard environmental flow.

Precharacterization Product

The product represented by this document is newly introduced and ZiLOG has not completed the full characterization of the product. The document states what ZiLOG knows about this product at this time, but additional features or nonconformance with some aspects of the document might be found, either by ZiLOG or its customers in the course of further application and characterization work. In addition, ZiLOG cautions that delivery might be uncertain at times, due to start-up yield issues.

ZiLOG, Inc.
532 Race Street
San Jose, CA 95126
Telephone (408) 558-8500
FAX 408 558-8300
Internet: www.zilog.com



Document Information

Document Number Description

The Document Control Number that appears in the footer on each page of this document contains unique identifying attributes, as indicated in the following table:

| | |
|------|--------------------------|
| PS | Product Specification |
| 0130 | Unique Document Number |
| 10 | Revision Number |
| 1003 | Month and Year Published |

Change Log

| Rev | Date | Purpose | By |
|-----|-------|---------------------------------------|------------------------|
| 01 | 01/02 | Original issue | D. Wilson, R. Beebe |
| 02 | 06/02 | Memory timing revisions | J. Eversmann, R. Beebe |
| 03 | 06/02 | Memory timing revisions | J. Eversmann, R. Beebe |
| 04 | 10/02 | Modifications to characteristics data | J. Eversmann, R. Beebe |
| 05 | 11/02 | Modifications to characteristics data | J. Eversmann, R. Beebe |
| 06 | 01/03 | Minor modifications to content | R. Beebe |
| 07 | 02/03 | Minor modifications to content | R. Johnson, R. Beebe |
| 08 | 06/03 | Modifications to characteristics data | C. Bender |
| 09 | 08/03 | Clarification to Tables 24 and 25 | E. Aquino, R. Beebe |
| 10 | 09/03 | Minor modifications | R. Beebe |



Index

Numerics

- 100-pin LQFP package 4, 20
- 20 MHz Primary Crystal Oscillator Operation 196
- 32 KHz Real-Time Clock Crystal Oscillator Operation 199

A

- Absolute Maximum Ratings 201
- AC Characteristics 204
- ACK—see Acknowledge
- Acknowledge 137, 141–145, 148, 152–153
- ADDR0 5, 20
- ADDR1 5, 20
- ADDR2 5, 20
- ADDR3 5, 20
- ADDR4 5, 20
- ADDR5 5, 20
- ADDR6 6, 21
- ADDR7 6, 21
- ADDR8 6, 21
- ADDR9 6, 21
- ADDR10 6, 21
- ADDR11 7, 21
- ADDR12 7, 21
- ADDR13 7, 21
- ADDR14 7, 21
- ADDR15 7, 21
- ADDR16 8, 21
- ADDR17 8, 21
- ADDR18 8, 21
- ADDR19 8, 21
- ADDR20 8, 21
- ADDR21 8, 21
- ADDR22 9, 21
- ADDR23 9, 21
- address bus 5–9, 46, 50, 52–57, 60, 63–64, 67–68, 88, 163–164, 174, 180
 - 24-bit 25

- Addressing 147
- Arbitration 139
- Architectural Overview 1
- asynchronous serial data 13, 15

B

- Baud Rate Generator 102, 107
 - Functional Description 129
- Block Diagram 2
- BRG Control Registers 107
- Bus Acknowledge 11, 22, 52, 164, 173, 180, 214
- Bus Arbitration Overview 135
- Bus Mode Controller 53
- Bus Request 11, 22, 52, 164, 173, 180
- Bus Requests During ZDI Debug Mode 163
- BUSACK—see Bus Acknowledge
- BUSREQ—see Bus Request
- Byte Format 137

C

- Change Log 218
- Characteristics, Electrical
 - Absolute Maximum Ratings 201
- Chip Select Registers 66
- Chip Select x Bus Mode Control Register 69
- Chip Select x Control Register 68
- Chip Select x Lower Bound Register 66
- Chip Select x Upper Bound Register 67
- Chip Select/Wait State Generator block 5–9
- Chip Selects and Wait States 48
- Chip Selects During Bus Request/Bus Acknowledge Cycles 52
- Clear To Send 14, 16, 116, 118
 - Delta Change Of 119
- Clock Peripheral Power-Down Registers 36
- Clock Phase 126–127, 132
- Clock Polarity 127, 132



Clock Synchronization 138
 Clocking Overview 135
 Continuous Mode 77
 CPHA—see Clock Phase
 CPHA bit 128
 CPOL—see Clock Polarity
 CPOL bit 128
 CS0 9, 21, 48–51
 CS1 9, 21, 48–51
 CS2 9, 21, 48, 50–51
 CS3 9, 21, 48, 50–51
 CTS—see Clear To Send
 CTS0 14, 122
 CTS1 16
 Customer Feedback Form 227
 Customer Information 227
 cycle termination signal 63–64

D

data bus 9–10, 52–53, 55–57, 60, 64, 70, 88,
 163–164, 174, 180
 Data Carrier Detect 14, 17, 115, 118
 Delta Change Of 119
 Data Set Ready 14, 16, 116, 118
 Delta Change Of 119
 Data Terminal Ready 14, 16, 116, 118
 Data Transfer Procedure with SPI configured
 as a Slave 130
 Data Transfer Procedure with SPI Configured
 as the Master 130
 data transfer, SPI 133
 Data Validity 136
 DATA0 9, 21
 DATA1 9, 22
 DATA2 10, 22
 DATA3 10, 22
 DATA4 10, 22
 DATA5 10, 22
 DATA6 10, 22
 DATA7 10, 22
 DC Characteristics 202
 DCD—see Data Carrier Detect
 DCD0 14, 122

DCD1 17
 DCTS—see Clear To Send, Delta Change Of
 DDCD—see Data Carrier Detect, Delta
 Change Of
 DDSR—see Data Set Ready, Delta Change Of
 Document Information 218
 Document Number Description 218
 DSR—see Data Set Ready
 DSR0 14, 122
 DSR1 16
 DTACK—see cycle termination signal
 DTR—see Data Terminal Ready
 DTR0 14, 122
 DTR1 16

E

Edge-Triggered Interrupts 42
 EI—see Interrupt Enable
 Op Code Map 189
 Electrical Characteristics 201
 Enabling and Disabling the WDT 72
 endec—see IrDA Encoder/Decoder
 Event Counter 79
 External Bus Acknowledge Timing 214
 External I/O Read Timing 208
 External I/O Write Timing 209
 External Memory Read Timing 204
 External Memory Write Timing 206
 External System Clock Driver (PHI) Timing 214
 eZ80[®] CPU 34–36, 51–52, 56–57, 63–64, 120,
 166, 182
 eZ80[®] CPU Core 32
 eZ80[®] CPU Instruction Set 185
 eZ80[®] Product ID Low and High Byte
 Registers 176
 eZ80[®] Product ID Revision Register 177
 eZ80L92 1–2, 4–5, 9–11, 19–20, 25, 34–35,
 39, 45–46, 48, 50, 71, 75, 79, 105, 107, 147,
 155, 157–158, 160–163, 166, 170–171,
 174–177, 180, 185, 196, 202, 204, 214, 216
 eZ80L92 Block Diagram 3

**F**

FAST mode 135, 155
 Features 1
 eZ80 CPU Core 32
 full-duplex transmission 128
 Functional Description, Infrared Encoder/
 Decoder 120

G

General Purpose I/O Port Input Sample Timing
 213
 General Purpose I/O Port Output Sample
 Timing 213
 General-Purpose Input/Output 39
 GND 2
 GPIO—see General-Purpose Input/Output
 GPIO Control Registers 43
 GPIO Interrupts 42
 GPIO Operation 39
 GPIO Overview 39

H

HALT instruction 11, 35, 170, 178, 187
 Op-Code Map 189
 HALT Mode 1, 36

I

I/O Chip Select Operation 50
 I/O space 5–10, 48, 50
 I²C Clock Control Register 154
 I²C Control Register 149
 I²C Data Register 149
 I²C General Characteristics 135
 I²C Registers 147
 I²C Serial Clock 20, 24, 135–137, 154
 I²C Serial I/O Interface 135
 I²C Slave Address Register 148
 I²C Software Reset Register 155
 I²C Status Register 152
 IEF—see Interrupt Enable Flag

IEF1 46–47, 178
 IEF2 46–47
 IM 0, Op Code Map 192
 IM 1, Op Code Map 192
 IM 2, Op Code Map 192
 Index 219
 Infrared Data Association 120
 Infrared Encoder/Decoder 120
 Register 123
 Signal Pins 122
 Input/Output Request 10–11, 22, 51, 53–54,
 56–57, 60
 INSTRD—see Instruction Read
 Instruction Read 11, 22
 Instruction Store 4
 0 Registers 174
 Intel- 53
 Intel Bus Mode 55
 Multiplexed Address and Data Bus 59
 Separate Address and Data Buses 56
 internal pull-up 40
 Interrupt Controller 45
 Interrupt Enable 11
 bit 87, 104, 150
 Interrupt Enable Flag 47, 178
 interrupt input 13–16, 18–20, 123
 Introduction to On-Chip Instrumentation 182
 Introduction, ZiLOG Debug Interface 156
 IORQ—see Input/Output Request
 IORQ Assertion Delay 208, 210
 IORQ Deassertion Delay 208, 210
 IORQ Hold Time 210
 IrDA—see Infrared Data Association
 IrDA Encoder/Decoder 13, 37, 123
 IrDA Receive Data 13
 IrDA specifications 121
 IrDA standard baud rates 121
 IrDA transceiver 123
 IrDA Transmit Data 13
 IRQ_EN bit 79, 81, 129, 132

J

Jitter, Infrared Encoder/Decoder 122



JTAG Test Mode 12

L

Level-Triggered Interrupts 42

Loopback Testing, Infrared Encoder/Decoder 123

Low-Power Modes 35

M

Maskable Interrupts 45

MASTER Mode 127, 135, 146, 150–155
 Start Bit 150
 Stop Bit 150

MASTER mode, SPI 128

Master Receive 135, 143

MASTER TRANSMIT mode 135, 140

MASTER_EN bit 129

Master-In, Slave-Out 19, 126, 128

Master-Out, Slave-In 126, 128

Memory and I/O Chip Selects 48

Memory Chip Select Example 49

Memory Chip Select Operation 48

Memory Chip Select Priority 49

Memory Request 10–11, 22, 48, 53–54, 56–57, 60

memory space 48, 50

MISO—see Master-In, Slave-Out

Mode Fault 126, 128, 133
 error flag 126, 128

Modem status signal 14, 16

MODF—see Mode Fault

MOSI—see Master-Out, Slave-In

Motorola Bus Mode 62

Motorola-compatible 53

MREQ—see Memory Request

multimaster conflict 128, 133

N

NACK—see Not Acknowledge

New and Improved Instructions, eZ80[®] CPU
 Core 32

NMI—see Nonmaskable Interrupts

Nonmaskable Interrupts 11, 22, 32, 36, 47, 71–73

Not Acknowledge 137, 141–142, 144–145, 150, 153

O

OCI—see On-Chip Instrumentation

OCI Activation 182

OCI Information Requests 184

OCI Interface 183

On-Chip Instrumentation 182

On-Chip Oscillators 196

Op Code maps 189

Open-Drain output 40, 135

open-source output 13–16, 18–20

Operating Modes 140

Operation of the eZ80L92 during ZDI
 Breakpoints 163

Ordering Information 216

Overview, Low-Power Modes 35

P

Packaging 215

Part Number Description 216

PB0 18, 23, 79

PB1 18, 23, 79

PB2 18, 24

PB3 18, 24

PB4 19, 24, 41, 79

PB5 19, 24, 79

PB6 19, 24

PB7 20, 24, 39

PC0 15, 23

PC1 15, 23

PC2 16, 23

PC3 16, 23

PC4 16, 23

PC5 16, 23

PC6 17, 23

PC7 17, 23, 41

PD0 13, 123



PD1 13, 23, 123
 PD2 13, 23, 123
 PD3 14, 23
 PD4 14, 23
 PD5 14, 23
 PD6 14, 23
 PD7 15, 23, 123
 Pin Characteristics 20
 Pin Description 4
 POP, Op Code Map 189, 191, 193
 Port x Alternate Register 1 44
 Port x Alternate Register 2 44
 Port x Data Direction Registers 44
 Port x Data Registers 43
 Power connections 2
 Precharacterization Product 217
 Problem Description or Suggestion 227
 Product Information 227
 Programmable Reload Timer 75
 Operation 76
 Registers 80
 Overview 75
 pull-up resistor, external 40, 135
 PUSH, Op Code Map 189, 191, 193

R

RD—see Read instruction
 RD Assertion Delay 209
 RD Deassertion Delay 209
 Read instruction 10, 11, 22, 48, 51, 53, 56–57, 60
 Reading the Current Count Value 78
 Real-Time Clock 86
 Real-Time Clock Alarm 87
 Control Register 100
 Day-of-the-Week Register 99
 Hours Register 98
 Minutes Register 97
 Seconds Register 96
 Real-Time Clock Battery Backup 87
 Real-Time Clock Century Register 95
 Real-Time Clock Control Register 100
 Real-Time Clock Day-of-the-Month Register 92
 Real-Time Clock Day-of-the-Week Register 91
 Real-Time Clock Hours Register 90
 Real-Time Clock Minutes Register 89
 Real-Time Clock Month Register 93
 Real-Time Clock Oscillator and Source Selection 87
 Real-Time Clock Overview 86
 Real-Time Clock Recommended Operation 87
 Real-Time Clock Registers 88
 Real-Time Clock Seconds Register 88
 Real-Time Clock Year Register 94
 Receive, Infrared Encoder/Decoder 121
 Recommended Usage of the Baud Rate Generator 107
 Register Map 25
 Request To Send 13, 16, 116, 118, 122
 RESET 10–11, 22, 34–36, 40, 48, 71–73, 87–88, 100, 107, 123, 129–130, 168, 170, 182–183
 RESET event 39
 RESET Operation 34
 RESET Or NMI Generation 72
 Reset States 49
 Resetting the I²C Registers 147
 Return Information 227
 RI—see Ring Indicator
 RI0 15, 122
 RI1 17, 41
 Ring Indicator 15, 17, 104, 116, 118
 Trailing Edge 119
 RTS—see Request To Send
 RTS0 13
 RTS1 16
 RxD0 13
 RxD1 15

S

Schmitt Trigger 11
 SCK—see SPI Serial Clock 18, 126
 SCK Idle State 127
 SCK pin 128, 132



SCK Receive Edge 127
 SCK signal 128
 SCK Transmit Edge 127
 SCL—see I²C Serial Clock
 SCL line 138–140
 SDA—see Serial Data 20, 24, 135–137, 139, 146
 serial bus, SPI 133, 134
 Serial Clock 126, 135
 Serial Clock, I²C 20
 Serial Clock, SPI 18, 126
 Serial Data 126, 135
 Serial Data, I²C 20
 Serial Peripheral Interface 1, 37, 45, 125–126, 128
 Setting Timer Duration 76
 Shift Left Arithmetic 142, 144, 148, 188
 Shift Right Arithmetic 188
 SINGLE PASS Mode 76
 SLA—see Shift Left Arithmetic
 SLA, Op Code Map 194, 195
 SLA, Op Code map 190
 SLAVE mode 135, 146, 148, 150, 153
 SLAVE mode, SPI 128
 Slave Receive 135, 146
 Slave Select 18, 126–128, 130, 132
 Slave Transmit 135, 145
 SLEEP Mode 35
 SPI—see Serial Peripheral Interface
 SPI Baud Rate Generator 129
 Register 28
 Registers—Low Byte and High Byte 130
 SPI Block 28
 SPI Control Register 28, 132
 SPI Data Rate 129
 SPI Flags 128, 133
 SPI Functional Description 128
 SPI interrupt service routine 46
 SPI master device 19–20, 130
 SPI MASTER mode 128
 SPI mode 18
 SPI Receive Buffer Register 28, 134
 SPI Registers 130
 SPI serial bus 133

SPI Serial Clock 18, 126
 SPI Signals 126
 SPI slave device 19, 20
 SPI SLAVE mode 128
 SPI Status Register 28, 133
 SPI Status register 129
 SPI Transmit Shift Register 28, 129–130, 133
 SPIF—see SPI Flags
 SPIF status bit 133–134
 SRA—see Shift Right Arithmetic
 SRA, Op Code Map 190, 194
 SS—see Slave Select
 STA—see MASTER Mode Start Bit 150
 standard mode 135
 START and STOP Conditions 136
 supply voltage 1, 40, 135, 201–202
 Switching Between Bus Modes 66
 system clock cycles 11, 51, 53–54, 57, 60, 64, 72, 182
 System Clock Oscillator Input 17
 System Clock Oscillator Output 17

T

TERI—see Ring Indicator, Trailing Edge 119
 Test Mode 183
 Time-Out Period Selection 72
 Timer Control Register 80
 Timer Data Register—High Byte 82
 Timer Data Register—Low Byte 82
 Timer Input Source Select Register 84
 Timer Input Source Selection 79
 Timer Output 79
 Timer Reload Register—High Byte 84
 Transferring Data 137
 Transmit, Infrared Encoder/Decoder 121
 TxD0 13
 TxD1 15

U

UART—see Universal Asynchronous Receiver/Transmitter



UART Baud Rate Generator Register —Low and High Bytes 107
 UART FIFO Control Register 112
 UART Functional Description 102
 UART Interrupt Enable Register 110
 UART Interrupt Identification Register 111
 UART Interrupts 104
 UART Line Control Register 113
 UART Line Status Register 116
 UART Modem Control 104
 Register 115
 UART Modem Status Interrupt 105
 UART Modem Status Register 118
 UART Receive Buffer Register 109
 UART Receiver 103
 Interrupts 104
 UART Recommended Usage 105
 UART Registers 109
 UART Scratch Pad Register 119
 UART Transmit Holding Register 109
 UART Transmitter 103
 Interrupt 104
 Universal Asynchronous Receiver/Transmitter 102

V

V_{CC} 2

W

WAIT 1, 11, 22, 57, 60, 63–64
 WAIT Input Signal 51
 WAIT pin, external 53–54
 Wait State Timing for Read Operations 211
 Wait State Timing for Write Operations 212
 WAIT states 46, 51, 54, 57, 60, 68, 164, 211–212
 Watch-Dog Timer 71
 Control Register 73
 Operation 72
 Overview 71
 Registers 73
 Reset Register 74

WCOL—see Write Collision
 WR—see Write instruction
 Write Collision 128–129, 133
 write collision, SPI 133
 Write instruction 10–11, 22, 48, 51, 54, 57, 60, 210

Z

Z80 Bus Mode 53
 ZCL—see ZDI clock pin
 ZDA—see ZDI data pin
 ZDI—see ZiLOG Debug Interface
 ZDI Address Match Registers 166
 ZDI Block Read 163
 ZDI BLOCK Write 161
 ZDI BREAK Control Register 167
 ZDI Bus Control Register 173
 ZDI Bus Status Register 180
 ZDI Clock and Data Conventions 158
 ZDI clock pin 158, 161, 168
 ZDI data pin 158, 168, 183
 ZDI Master Control Register 170
 ZDI Read Memory Register 180
 ZDI Read Operations 162
 ZDI Read Register Low, High, and Upper 178
 ZDI Read/Write Control Register 171
 ZDI Read-Only Registers 166
 ZDI Register Addressing 160
 ZDI Register Definitions 166
 ZDI SINGLE-BYTE READ 162
 ZDI SINGLE-BYTE Write 161
 ZDI Start Condition 158
 ZDI Status Register 178
 ZDI Write Data Registers 171
 ZDI Write Memory Register 175
 ZDI Write Operations 161
 ZDI Write-Only Registers 164
 ZDI_BUS_STAT 164, 166, 180
 ZDI_BUSACK_EN 163, 180
 ZDI-Supported Protocol 157
 ZiLOG Debug Interface 156
 ZiLOG Developer Studio 216
 ZDS—see ZiLOG Developer Studio



Customer Feedback Form

The eZ80L92 Product Specification

If you experience any problems while operating this product, or if you note any inaccuracies while reading this Product Specification, please copy and complete this form, then mail or fax it to ZiLOG (see *Return Information*, below). We also welcome your suggestions!

Customer Information

| | |
|----------------|---------|
| Name | Country |
| Company | Phone |
| Address | Fax |
| City/State/Zip | Email |

Product Information

| |
|--------------------------------|
| Serial # or Board Fab #/Rev. # |
| Software Version |
| Document Number |
| Host Computer Description/Type |

Return Information

ZiLOG
 System Test/Customer Support
 532 Race Street
 San Jose, CA 95126
 Phone: (408) 558-8500
 Fax: (408) 558-8536
[ZiLOG Customer Support](#)

Problem Description or Suggestion

Provide a complete description of the problem or your suggestion. If you are reporting a specific problem, include all steps leading up to the occurrence of the problem. Attach additional pages as necessary.
