

SMARTSCAN INFORMATION



SMARTSCAN Machinery Safety Systems

T4 LIGHT CURTAIN



The T4 light curtain breaks new ground for safety systems. It contains a core technology which is transported to all the new generation safety components from Smartscan. All T4 devices feature a programmable controller. The light curtain is in fact a programmable controller with I/O just like a safety PLC. The light curtain beams are a sensing unit providing another input to the PLC. Add to this the capability of networking up to 24 T4 components together with no additional hardware and the power of the distributed intelligence is almost limitless. Many other innovations, together with a new manufacturing plant, allow Smartscan to offer this product at a groundbreaking price.

- T4** 0.5-15 Meters Range
- T4** Muting inputs
- T4** Reset input
- T4** EDM input
- T4** Safety Outputs
- T4** 2 Auxiliary outputs
- T4** Zone Control
- T4** Program Selection
- T4** Data Link
- T4** Measuring function
- T4** Rated IP65
- T4** Safety Category 4

T4 SERIES LIGHT CURTAINS HANDBOOK

Smartscan Ltd, Pywell Road, CORBY, NN17 5XJ, UK, Tel: +44 (0) 1536 401313,
Fax: +44 (0) 1536 268954, Email: sales@smartscan.com, www.smartscan.com

	Page
INTRODUCTION	5
FEATURES	7
EXTENDED FEATURES	9
SPECIFICATION	10
LIGHT CURTAIN MODEL LIST	11
CONNECTION INFORMATION	13
INSTALLATION SHEET	16
ACCESSORIES	23
SAFETY SYSTEM SOLUTIONS	28
APPENDIX 1	29

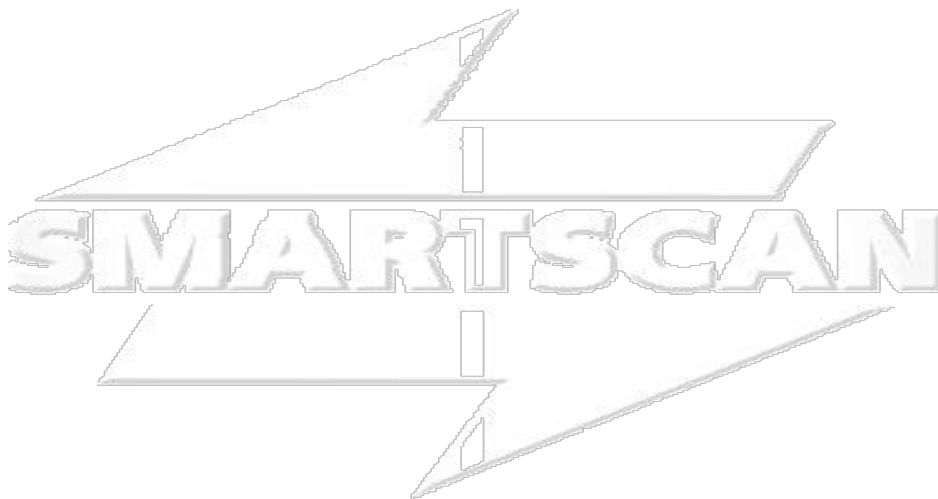

www.smartscan.com

INTRODUCTION

The T4 system is a Category 4 control solution which incorporates safety PLC functionality and a data link facility. The system is incorporated in a range of products manufactured by Smartscan.

The T4 Series meets the very highest standards for safety – Third Party Approved for compliance to the latest European Standards including BS EN 61496-1 and BS IEC 61496-2. Rated as a Type 4 device the T4 Series is suitable for ALL machine applications including those categorised 'high risk'.

The T4 Series Light Curtain offers a wide range of models for finger, hand, leg and body protection.

It is compact in size and provides many sophisticated control features as standard, including 2 and 3 beam floating blanking for press and press brake applications, external test and auto or latched reset control options. A muting function is also provided.



INTRODUCTION

T4 – an innovative Light Curtain system for industrial machinery applications.

Typical machine safeguarding applications include:

- Press brakes
 - Mechanical presses
 - Guillotines
 - Production lines
 - Robots
- 0.5-15 meters range achieved with no range switches
 - Muting inputs
 - Reset input (selectable manual/auto restart)
 - External device monitoring
 - Electronic safety outputs
 - 2 Auxiliary outputs (electronic)
 - Data link supports range of accessories

The T4 light curtain breaks new ground for safety systems. It contains a core technology which is transported to all the new generation of safety products from Smartscan. All T4 devices feature a programmable controller.

The T4 Light Curtain is in fact a programmable controller with inputs and outputs just like a safety programmable logic controller. The Light Curtain beams are a 'built in' sensing unit providing an internal input to the PLC.

The T4 Light curtain is supplied with a data link. This facility may be used to access additional configuration options such as changing timer values or selecting up to 16 additional modes of operation. It also may be used to connect the light curtain to SY4 safety relays or any other T4 compatible devices.

FEATURES

The Smartscan T4 light curtain looks like most other light curtains and can be connected up and used in the usual way. It ships with many features as standard as described in the features section. These allow the unit to be used in almost any application.

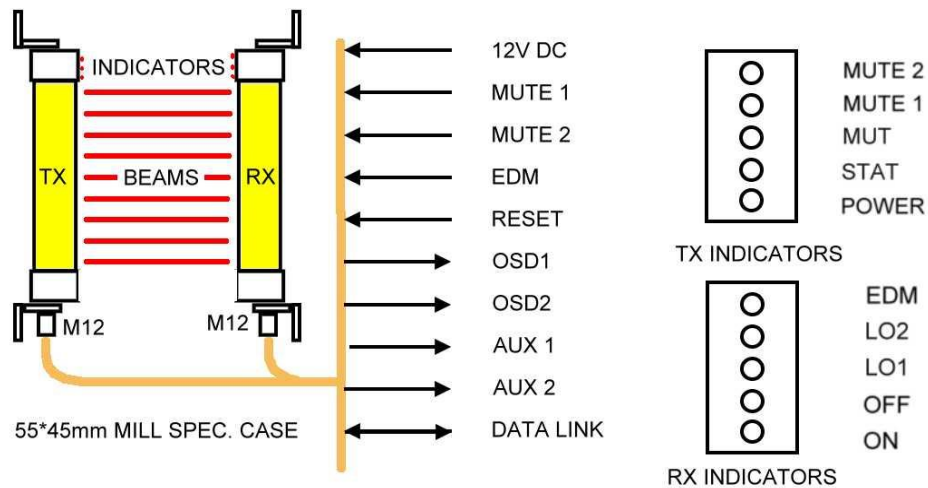

The aluminium extruded case is very robust with a closed cell design. This unique feature separates the sensitive circuits from the plant circuits giving the system outstanding electrical noise immunity while also imparting extremely high torsional strength.

The cables are connected via industry standard M12 connectors to the bottom of the guard.

The indicators are at the top of the guard providing greater visibility.

The robust mounting brackets are made of stainless steel giving many different ways of mounting and adjustment.

There are side slots which may be used in conjunction with a special mounting bracket which clips to a 30mm scaffold pole when a simple floor mount is required.

The unit also features a comprehensive array of LED display lights which give the operations personnel full information as to the state of the guard.

FEATURES

The reset to start control function is shown in the illustration. The user connections are made via 8 pin M12 connectors to both transmitter and receiver.

The light curtain may be operated in one of 2 modes depending on the way the reset and EDM functions are connected. See Installation Sheet Box E.

The reset to start mode incorporates the reset and EDM function. In this mode the guard requires a reset to close the OSSD's. The guard has a muting feature built in, with timers to facilitate the function when used in packaging applications.

The EDM function monitors the user's safety relay for correct operation.

Additionally there are 2 outputs which allow the user to indicate or monitor the status of the safety outputs or the mute function.

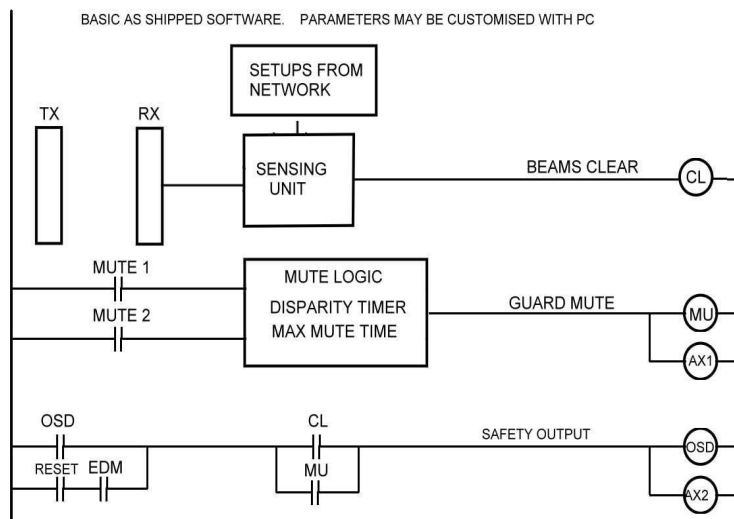

EXTENDED FEATURES

The design also features an RS232 link as standard.

The link can be used in the following ways:

- 1) Setting basic parameters such as mute timers.
- 2) Selecting an alternative logic function.
- 3) Downloading a new application program.
- 4) Operating a network of up to 24 T4 devices.
- 5) Monitoring the working system with PC.
- 6) Height Measuring.
- 7) Muting Functions

A PC can be directly connected to the data link.

T4 Components in a Network

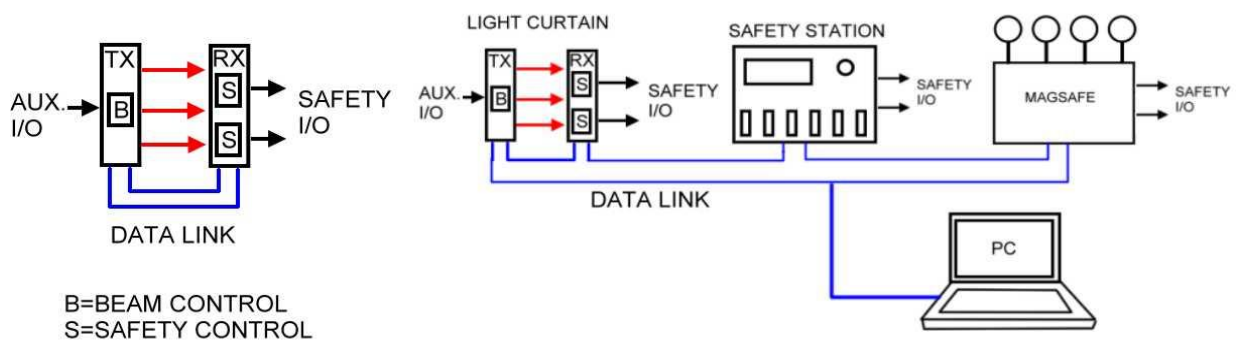

BASIC T4 LIGHT CURTAIN

T4 COMPONENTS IN NETWORK

The network illustration shows how T4 components may be connected together to produce a system. The devices occupy one of 24 nodes in the RS232 network. Any of the devices may be the master with the control program running in it. All devices have access to all the signals in the system.

A PC may form part of the system for problem solving or programming.

The functions shown comprises the default software which runs when the guard is powered up with RESET=0 and EDM=1.

The guard will work in auto-reset mode by powering up with RESET=1 and EDM=0. Mute is still operational and the guard may form a component of an external system which contains a reset function.

SPECIFICATION

T4 Series Light Curtains

Number of beams	1 - 128
Detection height	141 – 2391 mm
Range	Perimeter guard - 20 metres 14 mm guard - 5 metres 30 mm guard - 10 metres 40 mm guard - 15 metres
Light type	IR 880nm
Response time	20ms
Operating temperature	0°C to +50°C Heater Off -30°C to +40°C Heater On
Light curtain enclosure	IP65
Power supply	24V DC 2A ±10%
Current consumption	500mA maximum
Light curtain connection	M12 - 8 way pin - IP65
Finish	Aluminium chromate treated, yellow polyester powder coated
Classification	BS EN 61496-1 Type 4 BS IEC 61496-2 Type 4 BS EN 954-1 Category 4 BS EN 61508 SIL 3
Warranty	1 Year

OUTPUTS

Safety Outputs OSSD1 & OSSD2	Electronic 50 mA
Status Output	Electronic 50 mA
Mute Output	Electronic 50 mA
Status and Mute Indication	Status & condition LED's on Light Curtain

INPUTS

Safety Monitoring (EDM)	ON = +24V DC
Reset	ON = +24V DC 'Reset'
Mode select	Reset - Green = Reset (+) switch Yellow = EDM (+) Auto Reset - Green = L+ Yellow = L-
Muting	Dual Mute Inputs 24V DC = 'on'

LIGHT CURTAIN MODEL LIST

T4 Range of Light Curtains 30mm odc (10 metres range)

Model number	Number of beams	Detection height (mm)	Overall length (M) mm	Weight (TX + RX) Kg
050-301	6	141	317	1.15
050-302	12	291	467	1.72
050-303	18	441	617	2.32
050-304	24	591	767	2.88
050-305	30	741	917	3.50
050-306	36	891	1067	4.10
050-307	42	1041	1217	4.70
050-308	48	1191	1367	5.50
050-309	54	1341	1517	5.12
050-310	60	1491	1667	6.62
050-311	66	1641	1817	7.19
050-312	72	1791	1967	7.90
050-313	78	1941	2117	8.50
050-314	84	2091	2267	9.15
050-315	90	2241	2417	9.60
050-316	96	2391	2567	10.47

T4 Range of Light Curtains 40mm odc (15 metres range)

Model number	Number of beams	Detection height (mm)	Overall length (M) mm	Weight (TX + RX) Kg
050-401	6	141	317	1.15
050-402	12	291	467	1.72
050-403	18	441	617	2.32
050-404	24	591	767	2.88
050-405	30	741	917	3.50
050-406	36	891	1067	4.10
050-407	42	1041	1217	4.70
050-408	48	1191	1367	5.50
050-409	54	1341	1517	5.12
050-410	60	1491	1667	6.62
050-411	66	1641	1817	7.19
050-412	72	1791	1967	7.90
050-413	78	1941	2117	8.50
050-414	84	2091	2267	9.15
050-415	90	2241	2417	9.60
050-416	96	2391	2567	10.47

LIGHT CURTAIN MODEL LIST

T4 Range of Light Curtains 14mm odc (5 metres range)

Model number	Number of beams	Detection height (mm)	Overall length (M) mm	Weight (TX + RX) Kg
050-101	16	141	317	1.25
050-102	32	291	467	1.87
050-103	48	441	617	2.57
050-104	64	591	767	3.147
050-105	80	741	917	4.03
050-106	96	891	1067	4.78
050-107	112	1041	1217	5.43
050-108	128	1191	1367	6.29

T4 Range of Light Curtains for Perimeter Guarding (20 metres range)

Model number	Number of beams	Overall length (M) mm	Weight (TX + RX) Kg
050-602	2 @ 550	767	2.75
050-603	3 @ 450	1067	3.95
050-604	4 @ 400	1367	5.25

Interconnect Cables

Model number	Length (m)
051-005	5
051-010	10
051-020	20

CONNECTION INFORMATION

Note: Do not disconnect cables from the Transmitter (TX) or Receiver (RX) head with the power still connected to a T4 Series Light Curtain.

Safety Outputs OSSD1 and OSSD2 (F1)

Two independent electronic switches provide the failsafe outputs for connection to the machine control system. Connections are

Connections are Grey (OSSD1) and Pink (OSSD2) wires on the Receiver (RX) head cable. Outputs 'on' = 24V. (Light curtain clear/protecting) Outputs 'off' = 0V (Light curtain blocked) maximum switching current = 50mA

LED indicators located at the top of the Receiver (RX) head labelled as ON and OFF show the status of the OSSDs.

Green LED's ON = OSSD1 and OSSD2 active ON
Red LED's ON = OSSD1 and OSSD2 inactive OFF

Manual / Auto Reset Mode

Manual Reset - The Green wire on the Receiver (RX) head cable to be connected to a 'Normally Open' Reset switch contact block and the other side of the switch contact block needs to be at 24V DC. The Yellow wire on the Receiver (RX) head is used for the EDM (External Device Monitoring) with a normally closed contact of the external device and the other side of the contact to 24V DC. Note: If EDM is not used the Yellow wire must be connected to 24V DC.

Auto Reset – The Green wire on the Receiver (RX) head cable to be connected to 24V DC but if the EDM is required the Green wire will need to be connected to normally closed contact of the external device and the other side of the contact to 24V DC. The Yellow wire needs to be permanently connected to 0V DC.

Note: Changing the condition of the light curtain from manual to auto reset and visa-versa must be done with the power supply in the off-state.

LED indicators located at the top of the Receiver (RX) head labelled as EDM shows EDM status.

Yellow LED ON = EDM ON Yellow LED OFF = EDM OFF

Note: In auto reset mode the EDM LED is permanently off.

CONNECTION INFORMATION

Mute Function

There are 2 wires required to enable the mute function of the light curtain, Green wire (mute 1) and Yellow wire (mute 2) on the Transmitter (TX) head cable. The two mute inputs need to be at 24V DC switching to activate the light curtains mute function. Muting is the condition where the light curtain OSSD outputs will not respond to an interruption to the sensing field of the light curtain.

Both mute inputs are monitored with a disparity of 2 seconds therefore both signals must be supplied to the light curtain within 2 seconds of each other.

When the light curtain is in a mute condition it will activate an internal mute timer with a maximum time period of 15 minutes.

LED indicators located at the top of the Transmitter (TX) head labelled as MU1 (Mute 1), MU2 (Mute 2) and MUT (Light curtain Muted) show the status.

MU1 - Yellow LED ON = Mute 1 ON	Yellow LED OFF = Mute 1 OFF
MU2 - Yellow LED ON = Mute 2 ON	Yellow LED OFF = Mute 2 OFF
MUT - Yellow LED ON = Mute ON	Yellow LED OFF = Mute OFF *

*An external electronic mute output signal is also available from the Grey wire on the Transmitter (TX) head cable, mute-on = 24 vdc (rated at 24V DC 50mA) and mute-off = 0 vdc. This can be used to drive an external relay for remote indication via a beacon and/or an input to a PLC.

Status Output

The status output should only be used for non-safety critical application. E.g. connecting an indicator lamp or as feedback to a PLC to conform that the safety outputs have de-energised. The status output, Pink wire on the Transmitter (TX) head cable energises when the safety output OSSDs energise and de-energises when the safety outputs OSSDs de-energises. Status output ON = 24V DC 50mA and OFF = 0V DC

LED indicator located at the top of the Transmitter (TX) head labelled as STAT (Status) shows the condition.

STAT - Yellow LED ON = STATUS ON	Yellow LED OFF = STATUS OFF
----------------------------------	-----------------------------

CONNECTION INFORMATION

Power supply

Use a regulated supply +24V DC $\pm 10\%$, 0.5A. The White wire on both the Transmitter (TX) and Receiver (RX) head cables are to be connected to 24V DC (L+) and the Brown wire on both the Transmitter (TX) and Receiver (RX) head cables are to be connected to 0V DC (L-).

Caution: 0V (L-) of the power supply must be connected to ground.
No signal should exceed +24V DC $\pm 10\%$ (L+) or be less than 0V (L-)

Note: Any input or output signals not used must be terminated to an individual isolated terminal block.

Communication Link

The Transmitter (TX) and Receiver (RX) heads communicate via RS232. The Blue wire from the Transmitter (TX) head cable must be connected to the Blue wire from the Receiver (RX) head cable.

The Red wire from the Transmitter (TX) head cable must be connected to the Red wire from the Receiver (RX) head cable.

Caution: The Data wires are RS232 levels ($\pm 10V$) and must not be connected to any source that is not RS232 compatible.
Do not apply 24V DC to the data wires or it will damage the light curtain.

ACCESSORIES

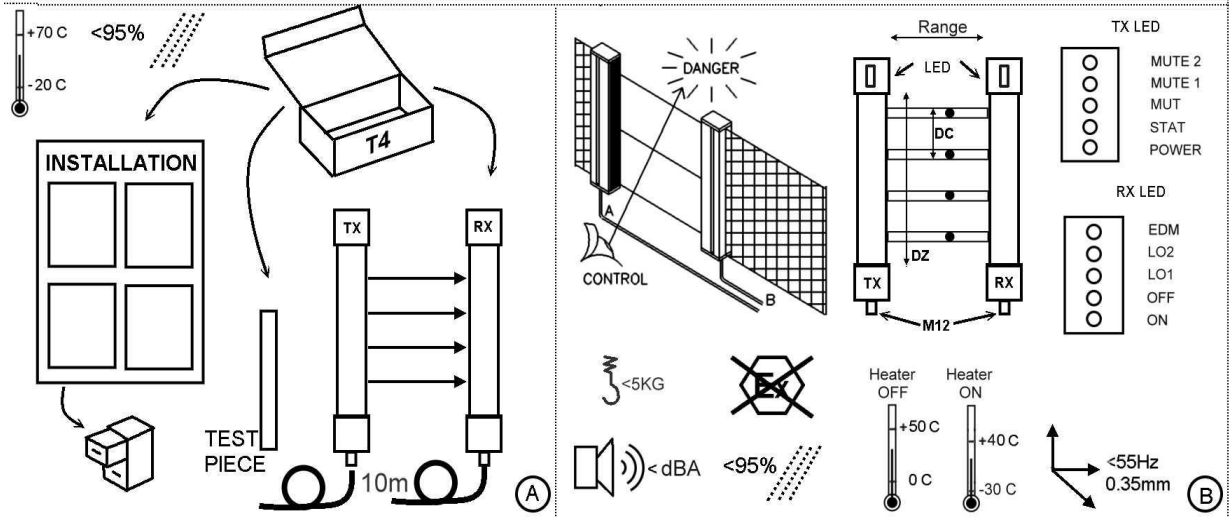

SIGNAL TX	RX	CORE	COLOR	LUM
24V	24V	1	RD	WH
OV	OV	2	BK	BN
MU1	RES	3	BN	GN
MU2	EDM	4	OR	YE
STAT	OSSD1	5	YE	GY
MU	OSSD2	6	GN	PK
RIN	TOUT	7	BU	BU
TOUT	RIN	8	PU	RD
--	--	SH	TAIL	

14mm Range = 5 m
 30mm Range = 10 m
 40mm Range = 15 m
 PERIMETER RG = 20 m

MODEL 30 ODC	MODEL 40 ODC	BEAMS	L
050-301	050-401	6	317
050-302	050-402	12	467
050-303	050-403	18	617
050-304	050-404	24	767
050-305	050-405	30	917
050-306	050-406	36	1067
050-307	050-407	42	1217
050-308	050-408	48	1367
050-309	050-409	54	1517
050-310	050-410	60	1667
050-311	050-411	66	1817
050-312	050-412	72	1967
050-313	050-413	78	2117
050-314	050-414	84	2267
050-315	050-415	90	2417
050-316	050-416	96	2567

MODEL 14 ODC	BEAMS	L
050-101	16	317
050-102	32	467
050-103	48	617
050-104	64	767
050-105	80	917
050-106	96	1067
050-107	112	1217
050-108	128	1367

PERIMETER	MODEL 14 ODC	BEAMS	L
	050-602	2	767
	050-603	3	1067
	050-604	4	1367

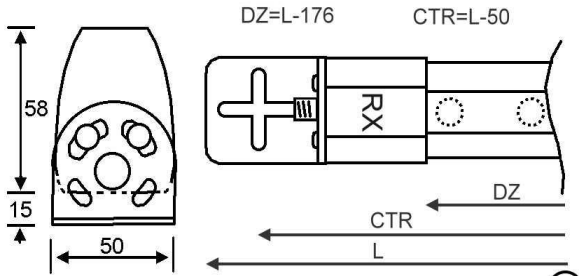

Dimension=mm

Dimension=mm

RESET MODE

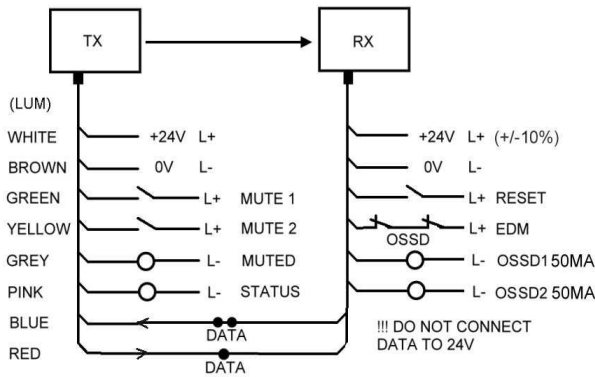

AUTO RESET MODE

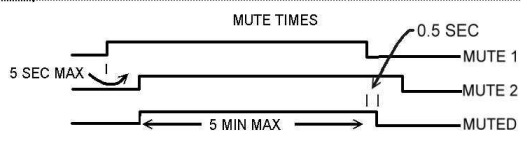
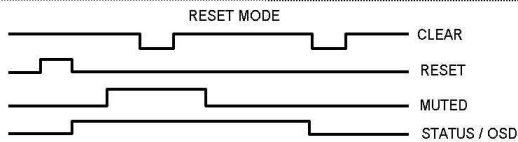
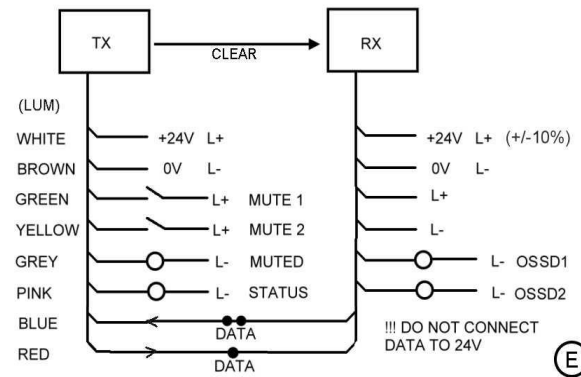

ACCESSORIES

EC DECLARATION OF CONFORMITY

Smartscan T4 Safety Control System

Smartscan Ltd. Pywell Rd. Corby, Northants. NN17 5XJ

declares that the safety component(s) described:
Serial Number: Between 800 000 and 899 999



fulfils the following safety function: Electro-sensitive protective equipment – active opto-electronic protective device (safety light curtain).
conforms to the following Directives:
98/37/EC, 89/336/EEC, 92/31/EEC, 73/23/EEC.
EN61496-1 Type 4 IEC61496-2 Type 4
uses the following standards:
EN292-1, EN292-2, EN60204-1, EN61496-1, IEC61496-2, EN954-1

complies with the examples to which the EC type examination certificate below relates, and is in conformity with the protection requirements of Council Directive 89/336/EEC, as amended, on the approximation of the laws of the Member States relating to electromagnetic compatibility, based on the technical construction file route to compliance in accordance with Article 10(2) of the EMC Directive.

The component is of a type listed in Annex IV of the Machinery Directive. Examples have been submitted for type examination by the approved body identified below:

CE Marking has been applied to this safety component under the terms of Directives 89/336/EEC, 92/31/EEC and 93/88/EEC.

Signature: *[Handwritten Signature]*

Date: *[Handwritten Date]*



MAINTENANCE

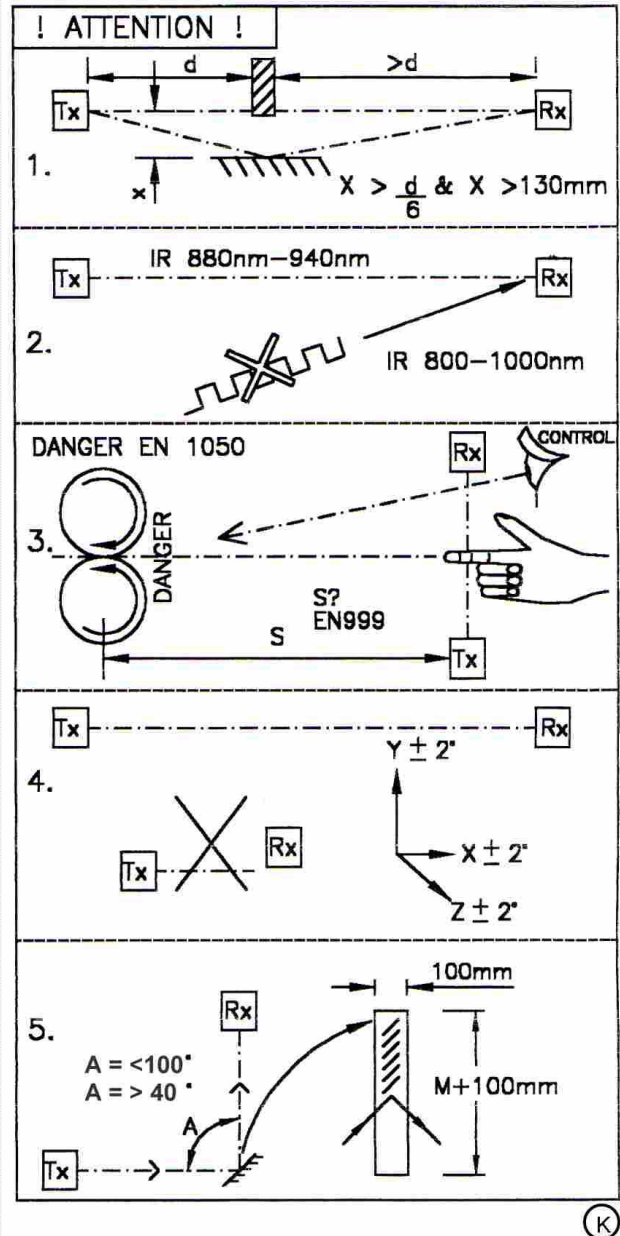
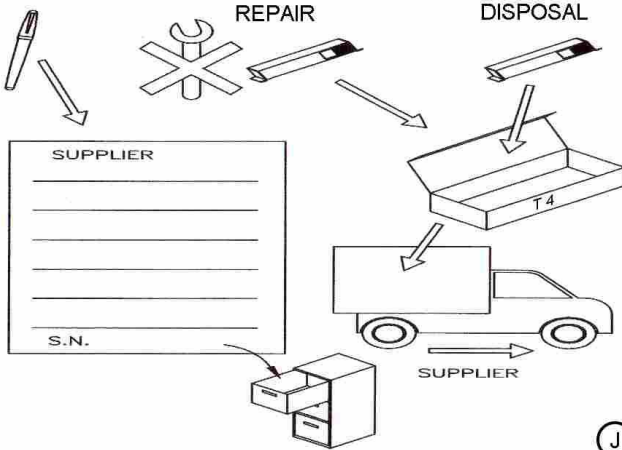
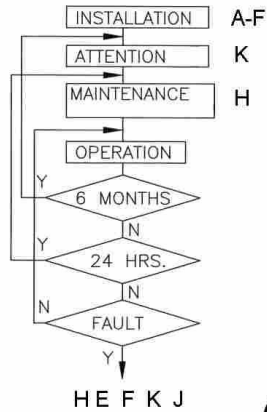
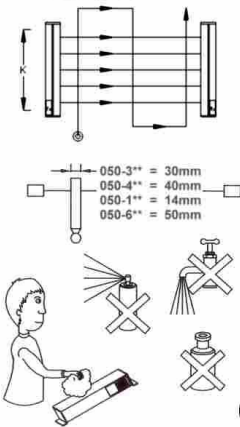

**SMARTSCAN
T-4**

Model 050-302
S.N. 800000
Yr. 2006
DC 30mm
RG 10m
DZ 251mm
IP 65
RESPONSE TIME 20ms
V = 24 I = < 500ma

IEC 61496-2 TYPE 4

Smartscan Ltd.
Corby,
NN17 5XJ, UK.
Tel +44(0)1536 401313
Fax +44(0)1536 268954
Email: Sales@smartscan.com



ACCESSORIES

BOX A

Components in Box A comprise the light curtain, test piece, cables and installation sheet.

The storage temperature should be in the range -20 to +70 Deg C.

BOX B

Running environment temperature should be in the range 0 to 50 Deg C. The guard has space heaters as standard. These are enabled using a PC and adjust the working range to -25 to 40 Deg C.

The designator for range is RG. The 30mm ODC guard has a working range of 0.5 to 10+ meters. The range may be adjusted using a PC. There are High and Low power settings, adjusting maximum range to 15 and 5 meters.

The designator DZ is the detection zone. It is in line with the first indicator lamp. It represents the zone in which the test piece will be detected.

The designator DC is the detection capability. This is the width of the test piece and is the distance between the outer edges of two adjacent beams.

The designator LED shows the position of the LED indicator panels present on both the heads. The 2 LED panels are illustrated.

The guard should not be operated in humidity greater than 95%. This is because water is likely to condense on the infra red window and reduce the maximum range.

The guard is not suitable for explosive environments without additional protection. Check with Smartscan for suitable enclosures.

The guard has no moving parts and emits no detectable sound.

The guard is not tested for vibrations greater than 0.35mm at 55 Hz. Where vibration is an issue - check with Smartscan for special mounting brackets.

BOX C

The Guard has industry standard M12 connectors. This pin-out of the connectors is shown. There are possibly 2 colour codes for the cables, be sure this is checked. The signals on the 8 cores are as shown. Where a screen is found, connect it to chassis ground.

ACCESSORIES

The case dimensions are as shown. The designator L is the overall length of the guard. The heads are the same length.

The Guard is supplied with stainless steel mounting brackets. These allow +/-15° adjustment in three mounting positions (ahead, forward and backwards). They are designed to stand off the guard so that cables can go behind the guard and the bracket mounted facing inwards if space is limited.

BOX D

The model list for 30 mm and 40 mm ODC guards.
The lengths are available in increments of 150mm for hand protection.

The model list for perimeter guards.
The lengths are available in 600mm, 900mm and 1200mm nominal for body protection.

Check with Smartsan for the availability of 14mm ODC guards for finger protection.

BOX E

Connection Information

CAUTION

0V (L-) of the power supply must be connected to ground.

CAUTION

No signal should exceed L+ or be less than L-

CAUTION

The Data wires are RS232 levels (+/-10V) and must not be connected to any source not RS232 compatible.

The input wires are resistively coupled to L- . The user activates the function by connecting the input to L+. The input will then draw 5mA.

The output wires are driven high and low by the guard. They can be used in both sink and source modes. They are rated at 60mA maximum. Damage may result if they are shorted to the supply voltage for an extended time. The outputs are not suitable for the coils of contactors controlling more than 2Kw. Always fit suppressors to inductive loads.

ACCESSORIES

In Reset mode -

The EDM must be at L+ when the guard is energised and must be at L+ in order for the OSSD to close. If external monitoring is not used, connect the EDM to L+. If EDM is used connect it to the relay closed auxiliary contacts.

In Auto Reset mode -

The EDM must be connected to L- at all times. It is not available as a function. The guard will act like a simple switch and the customer must provide the reset function in other equipment. Check with Smartscan for special function relays designed for this purpose.

CAUTION

If the EDM and RESET are not connected as instructed the guard will not start.

BOX F

Timing Diagrams

Reset Mode –

The four lines represent a sequence of events over time, showing how mute affects the output OSD.

The top line shows the clear status of the guard. There are 2 events where the guard is blocked.

The guard starts off in the clear condition. When a reset is applied the OSD will go ON at the time the reset switch is released. This is a fail safe feature of the reset circuit.

Next a mute condition is applied -

While muted the guard is blocked for a time—the OSD stays ON

Next the mute is removed—the OSD stays ON.

The next blocking event occurs when there is no mute and the OSD goes OFF.

CAUTION

Muting is a safe way of bypassing the safety function. The customer must ensure that the machine is in a safe condition at this time.

ACCESSORIES

Mute Times

Muting is a dual circuit safety function. It is necessary to ensure that both circuits are working. In order to do this timers are used.

Disparity Timer. This timer sets a limit on the time difference that occurs between the 2 mute signals when they come on. The default setting is 5 seconds. This time may be adjusted using a PC.

Mute Timeout. This timer sets a limit on the time the mute may remain on. The default setting is 5 minutes. This time may be adjusted using a PC.

Mute Off Timer. This timer is used to allow the product to clear the guard before the mute is cancelled. It is set to 0.5 seconds. The OSSDs will remain on for this period after the mute signal has been removed.

BOX G

It is a legal requirement that a Declaration of Conformity be included in this instruction. The document sets out the tests which the product has passed.

BOX H

The guard should be tested daily using the test piece. Each beam should be tested in the manner shown using the test piece.

The guard should not be cleaned with materials likely to damage the plastic window.

BOX I

Shows the lifetime maintenance procedures of the guard. It cross references the boxes associated with these actions.

BOX J

Note the supplier details and serial number on the installation sheet and file in a safe place. There are no user serviceable parts. A faulty guard must be returned to the supplier for disposal or repair.

ACCESSORIES

BOX K

Caution should be observed when installing the guard near to a reflective surface. Always check the beam nearest to the surface for possible bypass by reflections.

Care should be taken when installing modulated photocells near to the guard. They should not emit directly into the guard Receiver head.

The guard should not be mounted closer to a danger point than specified in EN999.

A Type 4 guard is required to have a very narrow beam angle in order to comply with EN61496 for use on presses with reflective surfaces.

BOX L

Representation of the rating label of the curtain. The same label is on both transmitter and receiver.

Important information shown on the label includes:

- Model Number
- Serial Number
- Year of Manufacture
- Detection Capability
- Maximum Operating Range
- Detection Zone (effective height)
- Response Time
- Operating Voltage and Current

ACCESSORIES

Mirror Units

Two or three sides of a machine can be safeguarded with a single light curtain by using mirrors to deflect the light curtain's infra-red beams.

The Smartscan mirror system provides a sturdy floor mounting kit together with an aluminium column for mounting the mirror. The mirror assembly simply slots onto the column and can be adjusted to the height required for the application.

The special mounting stand enables the mirror unit to be rotated through 360 degrees while also allowing full adjustment in all axes.

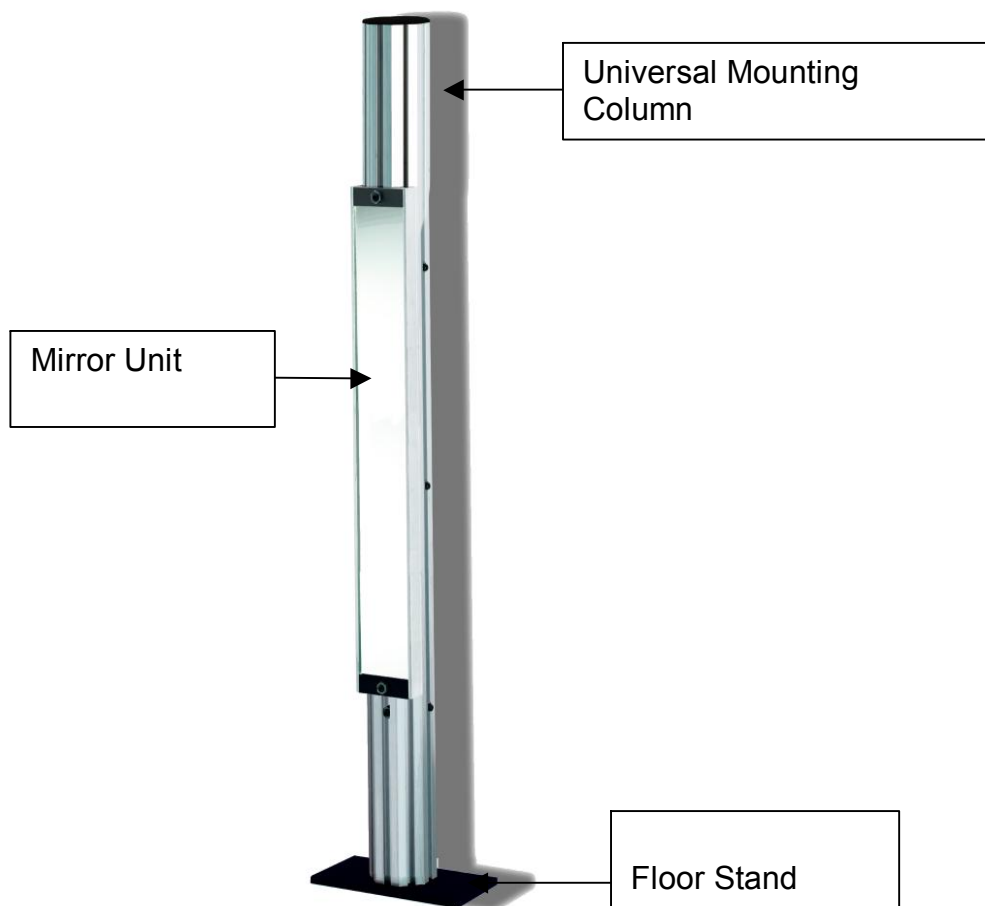

Note: Mirrors cause a reduction in optical efficiency, reducing the effective range of the light curtain. Refer to Appendix 1 for guidance.

ACCESSORIES

Range of the light curtain	Maximum range through 1 mirror	Maximum range through 2 mirrors
0.5m – 15m	9m	6m

Mirrors

Model number	Description
044-252	600mm x 110mm wide mirror unit
044-249	900mm x 110mm wide mirror unit
044-250	1200mm x 110mm wide mirror unit
044-253	1400mm x 110mm wide mirror unit

Note: Mirror length must be a minimum of 100mm longer than the overall length of the light curtain to be installed.

Column & Floor Stand

Model number	Description
044-256	1.1m aluminium universal mounting column
044-257	1.3m aluminium universal mounting column
044-258	1.6m aluminium universal mounting column
044-247	1.8m aluminium universal mounting column
044-262	2.0m aluminium universal mounting column
044-248	Floor stand

Note: A universal mounting column and floor stand is required for each mirror unit.

ACCESSORIES

Power Supply



If a suitable stabilised 24V DC, 2.5A power supply is not available the following unit is recommended.

Model number	Description
071-050	Power supply Input 85 - 264V AC Output 24V DC, 2.5A

Features

- ❑ High reliability
- ❑ High efficiency, low working temp
- ❑ Built in EMI filter, low ripple noise
- ❑ Compact size, lightweight
- ❑ Short circuit, over load, over voltage protection
- ❑ Approvals: UL, TUV, CB, and CE

Specification

Type	Switch mode
Input Voltage	85 - 264V AC
Input frequency	47-63HZ
Inrush current	Cold start, 24A, 115V & 50A, 230V
Output voltage/current rating	24V DC, 2.5A
Operating temperature	0°C to 50°C
Storage temperature	-10°C to +70°C
Connection	5P/9.5mm pitch terminal block
Enclosure	160x98x38mm Din rail mounting
Weight	0.5 Kg.

ACCESSORIES

Mounting Stands

Designed to accommodate our complete range of safety light curtains:

The **Adjustable Stand** (50mm x 50mm) offers the user a flexible mounting option. The stand has adjustable brackets that allow the safety light curtain to be mounted at different positions to suit a specific application.

The **Channel Stand** allows the user to mount the safety light curtain inside a protective housing. This provides protection on three sides to give a more robust installation. Channel stands would typically be used where the safety light curtain is at risk of damage from fork lift truck operations.

Adjustable Mounting Stands

Straight stands

Model number	Description	Height
044 – 408	Pair of adjustable straight stands (with complete bracket set)	2m

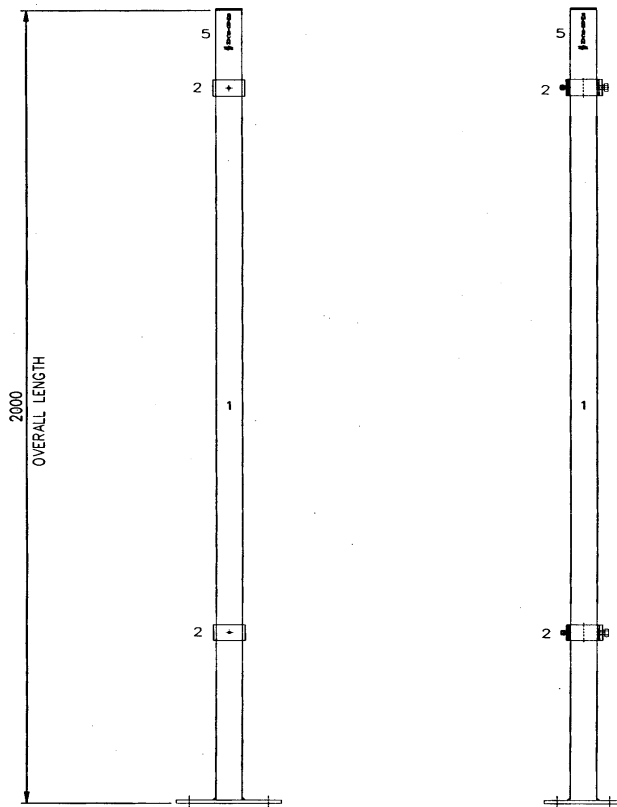

ACCESSORIES

Channel Mounting Stands

Straight stands

Model number	Description	Height
044 - 118	Pair of channel floor stands (straight)	1.5m
044 - 218	Pair of channel floor stands (straight)	2m

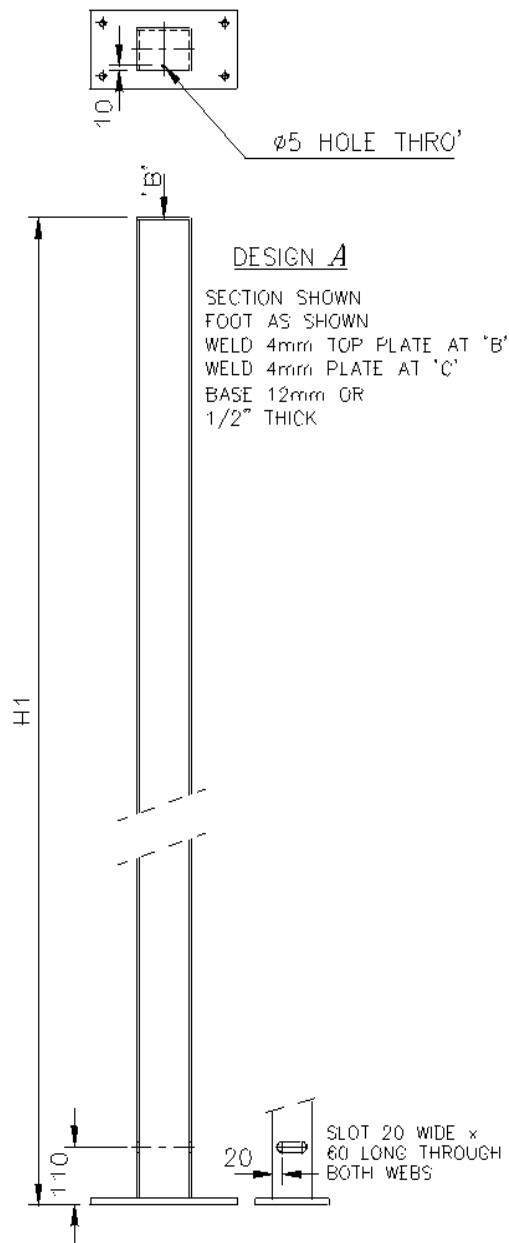

SAFETY SYSTEM SOLUTIONS



Smartsan recognise the difficult balance that customers have to make between meeting Health & Safety legislation requirements and managing their demanding production needs.

Smartsan design and manufacture systems to meet the particular needs of their customer's safety applications - from single machines to full production lines.

We provide our customers with a total service, from initial safety advice through to regular maintenance of their safety systems.



Expert Advice	Risk Assessment
Safety System Design	Product Specification
Safety System Installation	System Maintenance

APPENDIX 1

Mirrors

Reflector mirrors can be provided enabling two or three sides of a machine to be safeguarded with, what is effectively a single light curtain.

When mirrors are employed it is essential that the mounting of the transmitter unit, receiver unit and mirrors themselves are sufficiently rigid. Alignment becomes increasingly critical as the range and number of mirrors increase. Mirrors cause a reduction in optical efficiency, reducing the effective range. A guide to the practicality of using mirrors is given below.

Range of the light curtain	Maximum range through 1 mirror	Maximum range through 2 mirrors
0.5m - 5m	4m	3m
4m -10m	8m	6.5m

Total Light Path	1 Mirror	2 Mirror
2m	Easy	Easy
4m	Easy	Medium
6m	Medium	Hard
8m	Hard	Not Feasible

Note: Perimeter curtains will be easy to align, curtains over 900mm may be more difficult to align. Check with Smartcan technical department prior to ordering for a particular application.

support@smartscan.com, Tel: +44 (0) 1536 401313, Fax : +44 (0) 1536 268354

Note: The angle of the light curtain striking the reflective surface must be within defined limits.

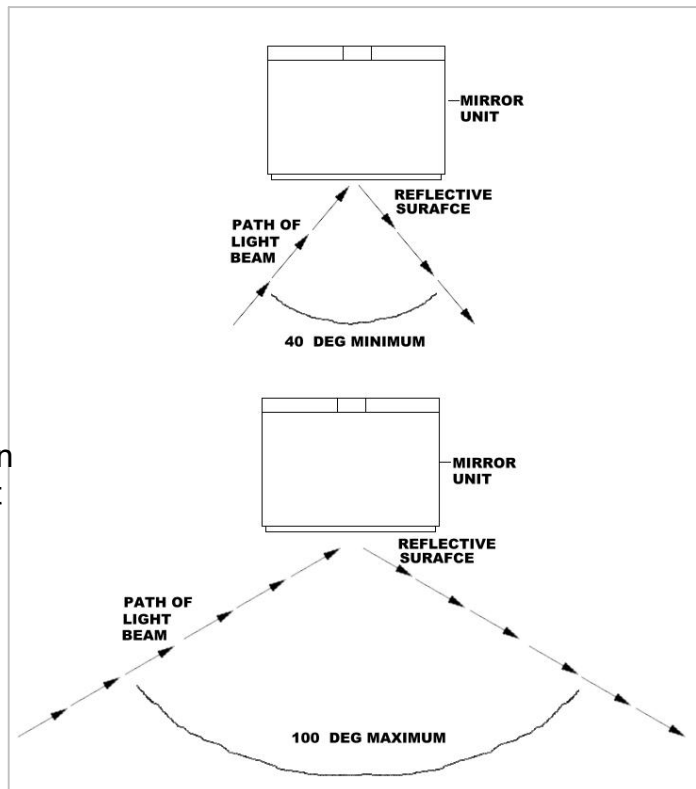

APPENDIX 1

Alignment through one mirror

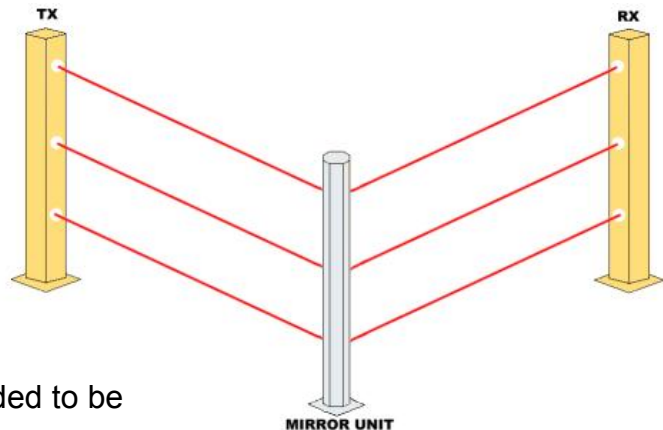

1. Secure the transmitter, receiver and mirror units in the position in which they are intended to be used.
2. Ensure all units are perfectly upright in all planes by using a spirit level.
3. If the units are floor mounted on stands ensure the floor is even. Shim the floor mounts if necessary to ensure the units are all upright.
4. With one eye looking over the top of the receiver unit in line with the centre of the extrusion look towards the reflective surface of the mirror, in a similar manner to looking through a gun sight.
5. A second person must adjust the mirror to the left and right until the Perspex window of the transmitter unit can be seen reflected in the mirror.
6. If the light curtain is scanning over a long range it may be difficult to see the reflection of the transmitter units Perspex window in the mirror. If so, cut a piece of white paper to the size of the Perspex window and mount directly in front of the window. Now repeat step 5.
7. If the reflection of the white paper is difficult to see in the mirror then employ a third person to hold a flashlight in front of the transmitter unit with the light beam pointing directly in line with the Perspex window towards the mirror. Now repeat step 5.
8. Use shims to ensure the mirror is accurately aligned to enable the infra red beams in the light curtain to reach the receiver. Alternatively, fabricate mirror mountings to include some form of adjustment to enable movement both left and right and also forward and backwards from the central axis of the mirror.

APPENDIX 1

Alignment through two mirrors

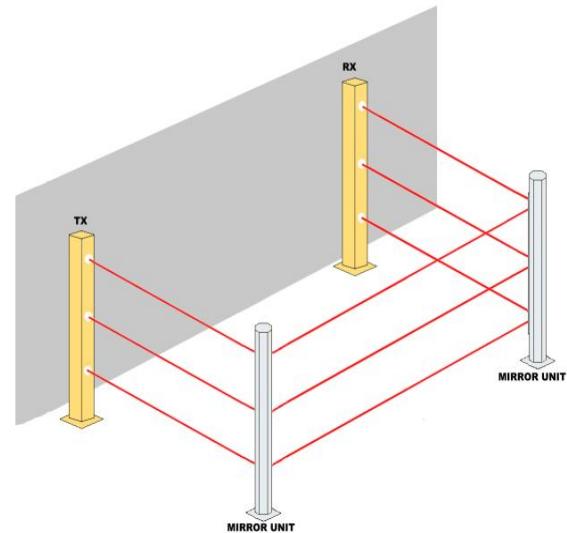

9. Follow instruction 1-4
10. A second person must adjust the position of the first mirror to the left and to the right until the entire length of the second mirror is reflected in the first mirror. If difficulties are experienced in seeing the reflection on the second mirror in the first mirror then use a piece of white paper cut to size and position in front of the second mirror.
11. If the reflection of the white paper is difficult to see in the first mirror then employ a third person to hold a flashlight in front of the second mirror with the light beam pointing directly in line with its mirror housing towards the first mirror. Secure the first mirror.
12. Again follow instructions 1 to 4.
13. The second person must adjust the position of the second mirror to the left and to the right until the entire length of the transmitter unit is reflected through both the first mirror and the second mirror. If difficulties are experienced in seeing the reflection of the transmitter unit through both the first then the second mirrors then use a piece of white paper cut to size and position in front of the transmitter unit.
14. If the reflection of the white paper is still difficult to see through the first and second mirrors then employ a third person to hold a flashlight in front of the transmitter unit with the light beam pointing directly towards the second mirror. Secure the second mirror.
15. Ensure the mirrors are directly aligned thus enabling the infra red beams of the transmitter to reach the receiver. Alternatively, fabricate mirror mountings to include some form of adjustment to enable movement both left and right and also forwards and backwards from the central axis of each mirror.

APPENDIX 1

- Now turn on the power to the light curtain and check that the green LED beam indicator, mounted on the receiver unit is 'on'. If not, it may be necessary to finely adjust each mirror in turn to ensure the infra-red energy from the transmitter unit is being reflected through the mirror(s) to the corresponding receiver unit.

Alignment of the light curtain using mirrors

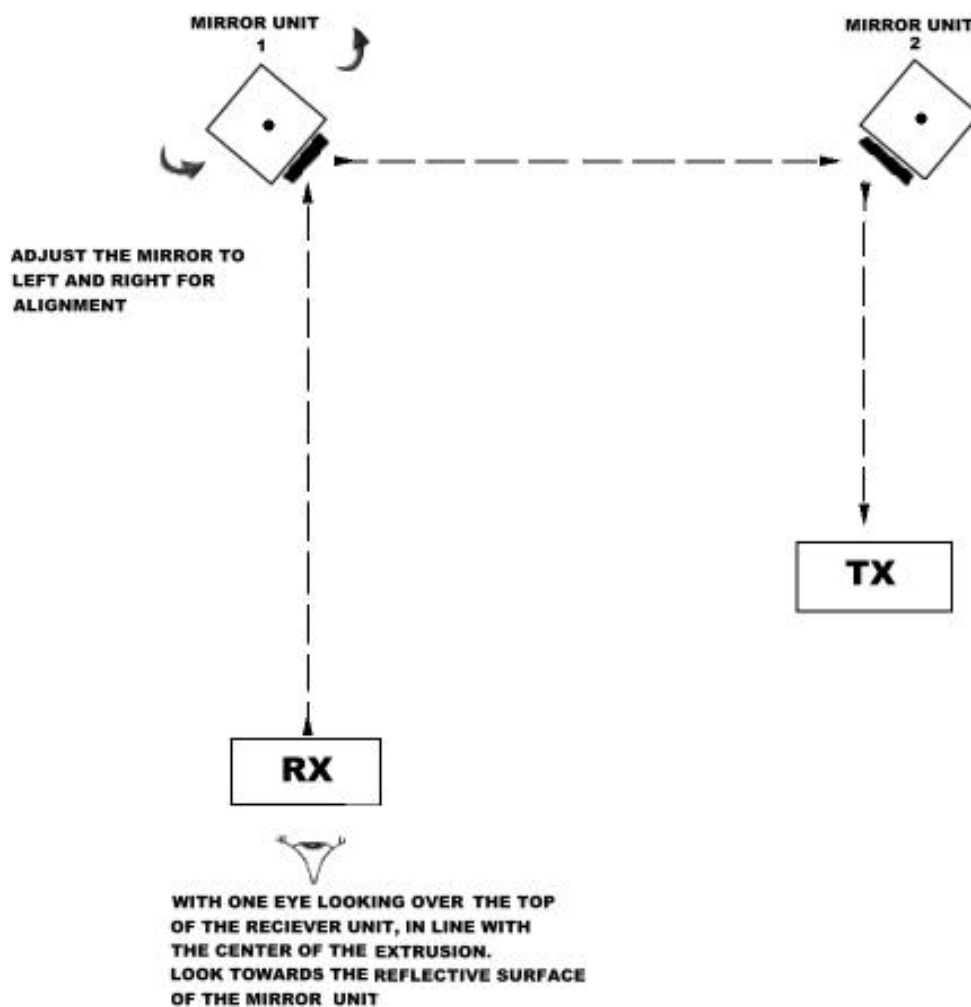

Note: The mirror length must be a minimum of 100mm longer than the overall length of the light curtain to be installed eg. 50mm above and 50mm below either end of the light curtain