

FEMALE END VIEW

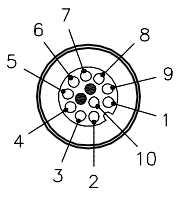

- 1 = WHITE
- 2 = BROWN
- 3 = GREEN
- 4 = YELLOW
- 5 = GREY
- 6 = PINK
- 7 = BLUE
- 8 = RED
- 9 = ORANGE
- 10 = TAN



SPECIFICATIONS

CONTACT CARRIER MATERIAL	NYLON OR TPU
MOLDED HEAD MATERIAL/COLOR	TPU/YELLOW
CONTACT MATERIAL/PLATING	BRASS/GOLD
COUPLING NUT MATERIAL/PLATING	BRASS/NICKEL
RATED CURRENT [A]	2.0 A
RATED VOLTAGE [V]	60 VAC/75 VDC
OUTER CABLE JACKET MATERIAL/COLOR	TPU/GRAY
CONDUCTOR INSULATION MATERIAL	PVC
NUMBER OF CONDUCTORS [AWG]	10x24 AWG
TEMPERATURE RANGE	-40°C to +90°C (-40°F to +194°F)
PROTECTION CLASS	NEMA 1,3,4,6P AND IEC IP68, IP69K

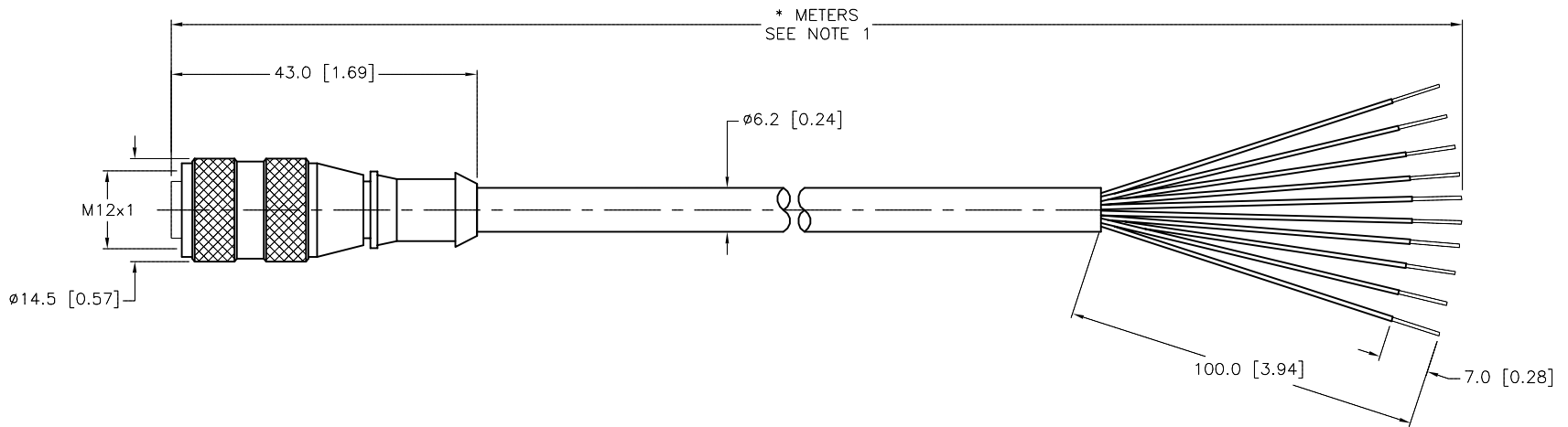

CABLE LENGTH	TOLERANCE*
ALL LENGTHS	+ 4% (OR 50mm) OF LENGTH - 0% (OR 0mm) OF LENGTH WHICHEVER IS GREATER
STRIP LENGTH	TOLERANCE*
0-7mm	±0.5mm
8-29mm	±1.0mm
30-49mm	±2.0mm
50-69mm	±3.0mm
70-100mm	±4.0mm
OVER 100mm	±5.0mm

* UNLESS OTHERWISE SPECIFIED

NOTES:

- "*" INDICATES CABLE LENGTH IN METERS. CONTACT TURCK TO ORDER SPECIFIC LENGTHS.
- "/S90" DESIGNATES THERMOPLASTIC POLYURETHANE (TPU) CABLE JACKET.

SOURCE DRAWING - FOR REFERENCE ONLY

RELATED DOCUMENTS 1. 2. 3. 4.	3RD ANGLE PROJECTION 	THIS DRAWING IS CONFIDENTIAL AND THE PROPERTY OF TURCK INC. USE OF THIS DOCUMENT WITHOUT WRITTEN PERMISSION IS PROHIBITED.		3000 CAMPUS DRIVE MINNEAPOLIS, MN 55441 1-800-544-7769 (763) 553-7300 (763) 553-0708 fax turck.com	
	MATERIAL SEE SPECIFICATIONS	DRFT RDS APVD	DATE 10/24/03 SCALE 1=1.0	DESCRIPTION RK 10T-*/S90	
FINISH SEE SPECIFICATIONS	ALL DIMENSIONS DISPLAYED ON THIS DRAWING ARE FOR REFERENCE ONLY	UNIT OF MEASUREMENT MILLIMETER [INCH]		IDENTIFICATION NO.	REV G
G UPDATE TEMP SPEC	RDS 01/10/13 40914	DO NOT SCALE THIS DRAWING		FILE: 777002666	SHEET 1 OF 1

REV	DESCRIPTION	BY	DATE	ECO NO.
G	UPDATE TEMP SPEC	RDS	01/10/13	40914