

28L28

Precious Metal Commutation System - 9 Segments

11 Watt

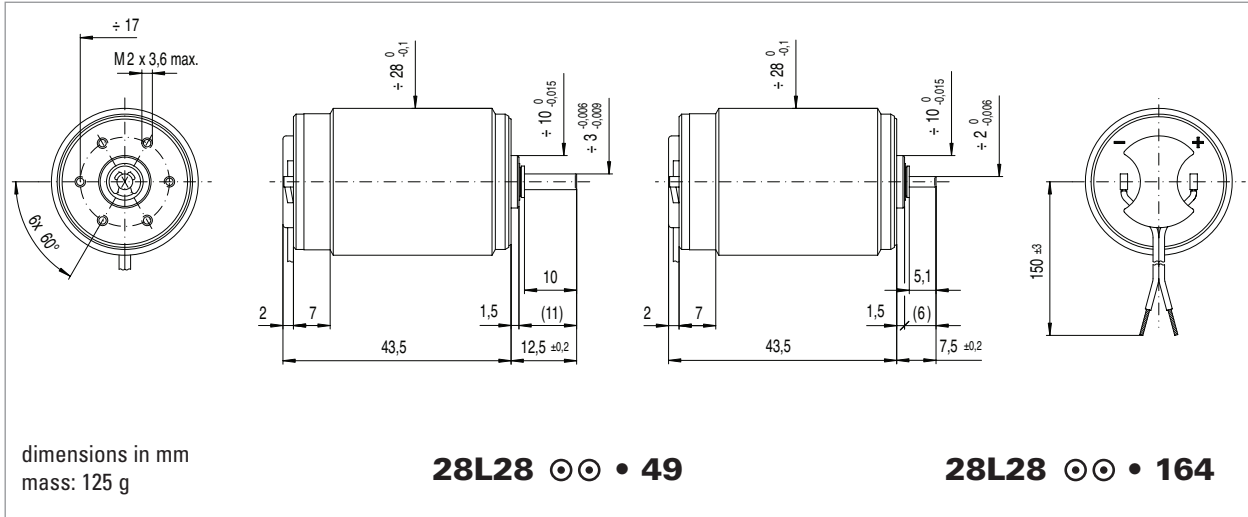

Winding Type	☉☉	-219	-416E	-413E	-410E	-410
Measured Values						
Measuring voltage	V	12.0	24.0	28.0	36.0	36.0
No-load speed	rpm	5300	5600	5300	5000	5000
Stall torque	mNm (oz-in)	43 (6.11)	50 (7.08)	42 (5.96)	34 (4.87)	34 (4.87)
Average No-load current	mA	22.0	11.0	8.8	6.6	6.6
Typical starting voltage	V	0.10	0.15	0.20	0.40	0.40
Max. Recommended Values						
Max. continuous current	A	0.95	0.53	0.40	0.28	0.28
Max. continuous torque	mNm (oz-in)	19.9 (2.82)	21.0 (2.97)	19.7 (2.78)	18.3 (2.58)	18.3 (2.58)
Max. angular acceleration	10 ³ rad/s ²	77	48	58	67	67
Intrinsic Parameters						
Back-EMF constant	V/1000 rpm	2.24	4.26	5.20	7.1	7.1
Torque constant	mNm/A (oz-in/A)	21.4 (3.03)	40.7 (5.76)	49.7 (7.03)	67.8 (9.60)	67.8 (9.60)
Terminal resistance	ohm	5.95	19.5	33.0	71.0	71.0
Motor regulation R/k ²	10 ³ /Nms	13	12	13	15	15
Rotor inductance	mH	0.50	2.40	3.20	7.1	7.1
Rotor inertia	kgm ² 10 ⁻⁷	10.40	17.50	13.50	11.00	11.00
Mechanical time constant	ms	14	21	18	17	17

Executions			
		Single Shaft	Double Shaft for E9
Gearbox	Page	28L28	28L18
R22	239	164	317
M22	240	164	317
RG1/8	245	49	315
RG1/9	246	49	315
R32	243	49	315
K38	244	49	315
K40	247	49	315

- Thermal resistance: rotor-body 5 °C/W
body-ambient 12 °C/W
- Thermal time constant - rotor / stator: 20 s / 760 s
- Max. rated coil temperature: 100°C (210°F)
- Recom. ambient temperature range: -30°C to +85°C (-22°F to +185°F)
- Viscous damping constant: 0.5 x 10⁻⁶ Nms

