

# OV2715 full HD (1080p) product brief



## OmniVision's True 1080p High Definition (HD) Video Image Sensor



available in  
a lead-free  
package

The OV2715 is a native 1080p high definition (HD) CMOS image sensor designed specifically to deliver HD video to security/surveillance applications. Built with OmniVision's proprietary OmniPixel3-HS™ technology, the 1/2.7-inch OV2715 addresses the low-light performance requirements of both IP cameras and HDcctv.

The OV2715 is one of the first no-compromise full 1080p HD sensors available on the market with a display resolution of 1920 x 1080 pixels while operating at 30 frames per second. The sensor delivers low-light sensitivity of 3300 mV/lux-sec and a peak dynamic range of 69 dB. This enables cameras to operate in virtually every lighting condition from bright daylight to nearly complete darkness, a critical capability for security and surveillance cameras.

The sensor provides full frame, sub-sampled or windowed 8-bit/10-bit images in raw RGB format via the digital video port with complete user control over image quality. It incorporates advanced image processing functions, including exposure control, gain control, white balance, lens correction and defective pixel correction, and is fully programmable through the serial camera control bus (SCCB) interface.

Offering a zero degree chief ray angle, the OV2715 allows for the clearest possible picture and best-in-class image quality. The OV2715 is capable of operating within a temperature range of -30°C to +70°C, enabling its implementation in indoor and outdoor security and surveillance applications.

Find out more at [www.ovt.com](http://www.ovt.com).



## Applications

- Security & Surveillance

## Product Features

- programmable controls: gain, exposure, frame rate, image size, horizontal mirror, vertical flip, cropping, windowing, and panning
- automatic image control functions:
  - automatic exposure (AEC)
  - automatic gain control (AGC)
  - automatic white balance (AWB)
  - automatic black level calibration (ABLC)
- serial camera control bus (SCCB)
- lens correction (LENC)
- defective pixel correction (DPC)
- support for digital video port (DVP) parallel output interface
- integrated auto focus filter
- support for one lane MIPI interface (up to 800 Mbps)
- support for 8-/10-bit RAW RGB output format
- support for image sizes:
  - 1080p
  - cropped 720p
  - VGA
  - QVGA
- support for black sun cancellation
- embedded one-time programmable (OTP) memory
- on-chip phase lock loop (PLL)
- built-in 1.5 V regulator for core

# OV2715

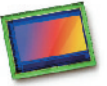

## Ordering Information

- OV2715-A68A (color, lead-free, 68-pin CSP3)

## Product Specifications

- active array size: 1920 x 1080
- dynamic range: 69 dB
- power supply:
  - analog: 3.0 - 3.6 V (3.3 V typical)
  - core: 1.425 - 1.575 V (1.5 V typical)
  - I/O: 1.7 - 3.6 V (1.8 V typical)
- power requirements:
  - active: 350 mW
  - power down: 70  $\mu$ A
- temperature range:
  - operating: -30°C to 70°C
  - stable image: 0°C to 50°C
- output interfaces: 10-bit parallel/one lane MIPI
- output formats: 10-bit RAW RGB
- lens size: 1/2.7"
- lens chief ray angle: 0°
- input clock frequency: 6 - 27 MHz
- maximum image transfer rate:
  - 1080p: 30 fps
  - cropped 720p: 60 fps
  - VGA: 120 fps
  - QVGA: 240 fps
- sensitivity: 3300 mV/lux-sec
- shutter: rolling
- S/N ratio: 39 dB
- pixel size: 3  $\mu$ m x 3  $\mu$ m
- dark current: 20 mV/sec @ 60°C
- well capacity: 13 Ke<sup>-</sup>
- image area: 5856  $\mu$ m x 3276  $\mu$ m
- package dimensions: 7465  $\mu$ m x 5865  $\mu$ m

## Functional Block Diagram

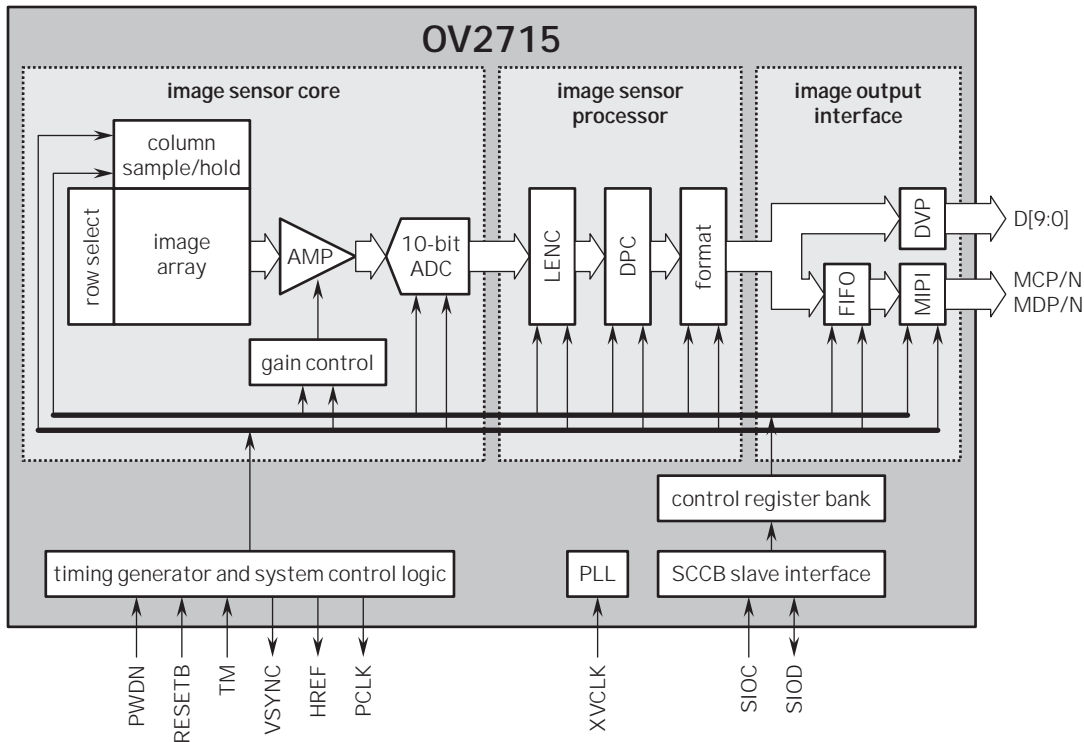

4275 Burton Drive  
Santa Clara, CA 95054  
USA

Tel: + 1 408 567 3000  
Fax: + 1 408 567 3001  
www.ovt.com

OmniVision reserves the right to make changes to their products or to discontinue any product or service without further notice. OmniVision, the OmniVision logo and OmniPixel are registered trademarks of OmniVision Technologies, Inc. OmniPixel3-HS is a trademark of OmniVision Technologies, Inc. All other trademarks are the property of their respective owners.

OmniVision