

Embedded Systems

NEW

VIA VIPRO VP7806

Fanless Panel PC with 6.5"
TFT LCD and Touch Screen



Features

- Fanless and ultra low power consumption
- Built-in VIA new generation 1.3GHz VIA Nano™ processor with L2 cache 1MB memory
- 6.5" TFT LCD panel with 5-wire resistive touch screen
- Built-in 2M CMOS camera, speakers and microphone on the front
- Integrated VIA Chrome9™ HC3, DX9 3D/2D graphics & video processor with MPEG-2/4 and WMV9 decoding acceleration
- Supports two Gigabit Ethernets, four COM ports and four USB 2.0 ports
- IP65 front panel compliant against water and dust



Specifications

Computing System	Processor	1.3GHz VIA Nano™
	Front Side Bus	800 MHz
	L2 Cache	1 MB
	Chipset	VIA VX800 Unified Digital IGP chipset
	BIOS	Award 8MBit SPI Flash BIOS Supports Diskless Boot to BIOS ROM (Free DOS operation system environment)
	System Power Management	Times Power on, ACPI supported
Memory	Technology	1 x DDR2 533/667 200-pin SDRAM SODIMM socket
	Max. Capacity	Up to 2GB memory size
Graphic	Controller	Integrated VIA Chrome9™ HC3 DX9 3D/2D graphics with MPEG-2/4 WMV9 decoding acceleration
	Display Memory	Optimized shared memory architecture, supports up to 256 MB frame buffer using system memory
	External Display interface	Supports 1 x External VGA port by a DB-9 connector Supports 1 x 24-bit signal channel LVDS interface by a DB-26 connector
LCD Display	LCD Type	6.5" color TFT LCD panel LED driving
	Resolution/Color	Up to 640 x 480 @262K
	Pixel Pitch (mm)	0.207 x 0.207
	Viewing Angle	80° (right), 80° (left), 70° (up) and 70° (down)
	Luminance (cd/m²)	700 cd/m ²
	LED Backlight MTBF	50,000 hours (typical)
Touch Screen	Type	5-Wire Analog resistive
	Transparency	80% ± 3%
	Controller	Built-in system a EETI ETP-CP-S5XU, USB interface controller
	Software Driver	Supports Windows XP and Windows 7
	Durability (Knock Test)	35 million
Ethernet	Controller	Built-in system two VIA VT6130 Gigabit Ethernet controllers
	Interface	Supports two RJ45 connector Supports Wake-on LAN (WOL) Supports Preboot Execution Environment (PXE)
Audio	Controller	VIA VT1708B High Definition Audio Codec
	External Speakers	Supports left and right speakers on front bezel
	External Microphone	Supports microphone on front bezel
Serial	USB	4 x USB ports, USB 2.0 compliant
	Serial Ports	4 x COM ports of 2 x RS-232 & 2x RS-232/422/485 (BIOS selectable)
Storage	HDD	1 x 2.5" drive bay
	Compact Flash	1 x Type I/II socket
System Indicator	Power Status LED	1 x Red color LED
	HDD Activity LED	1 x Green color LED

Top System I/O

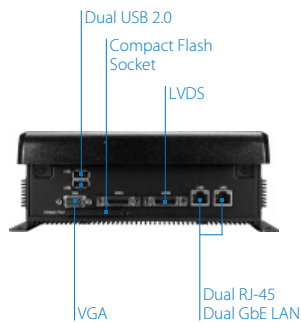

Bottom System I/O

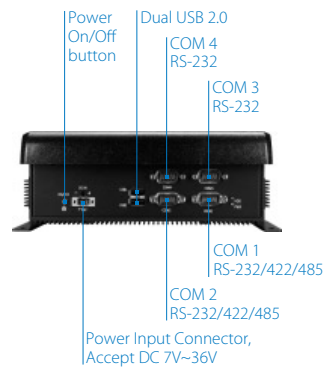

Front & Side I/O

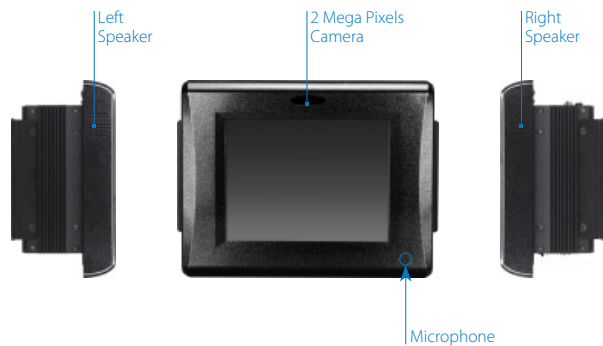

Specifications

Other	Camera	Built-in a 2 Mega Pixels of CMOS camera on the front bezel
Watchdog Timer	Output	System reset
	Interval	Programmable 1~255 sec
System I/O	Top I/O Coastline on PC Unit	1 x DB-9 connector for a VGA/CRT interface 2 x USB mini-DIN connectors 1 x DB-26 connector for a 24-bit single channel LVDS interface 2 x RJ45 connectors for dual Gigabit Ethernet connection
	Bottom I/O coastline on PC Unit	1 x HDD & PWR LED 2 x RS-232/422/485 COM port connectors as COM 1 and COM2 2 x RS-232 COM port connectors as COM3 and COM4 2 x USB mini-DIN connectors 1 x 2-pole of Phoenix power input connector 1 x ATX power on/off switch
Power Supply	Input Voltage	Built-in onboard DC-to-DC converter Accept wide range of power input of DC 7V ~ 36V Typical power input 7 VDC @ 2.64 A 12 VDC @ 1.54 A 16 VDC @ 1.15 A 19 VDC @ 0.97 A 24 VDC @ 0.77 A 36 VDC @ 0.51 A
	Input Power Protection	Supports over voltage protection Supports over current protection Supports under voltage protection
Mechanical	Construction	Aluminum mixed with heavy-duty steel
	Mounting	Panel/wall/table mountable
	Dimensions (W x H x D)	203 x 165 x 78.42 mm (7.9" x 6.5" x 3")
	Weight	3 kg (6.6 lbs)
Environmental Specification	Operating Temperature	0°C ~ 45 °C for HDD, -20 ~ 60°C for CF
	Storage Temperature	-20°C ~ 70 °C
	Relative Humidity	0 ~ 90% @ 45°C, non-condensing
	Vibration Loading During Operation	When system is equipped with 2.5" hard disk drive: up to 1Grms, IEC 60068-2-64, random, 5 ~ 500Hz, 1 Oct./min, 1hr/axis When system is equipped with Compact Flash disk: up to 5Grms, IEC 60068-2-64, random, 5 ~ 500Hz, 1 Oct./min, 1hr/axis
	Shock During Operation	When system is equipped with 2.5" hard disk drive: up to 20G, IEC 60068-2-27, half size, 11ms duration When system is equipped with Compact Flash disk: up to 50G, IEC 60068-2-27, half size, 11ms duration
	Front Panel Protection	IP65 compliant
	EMC Approved	CE, FCC Class A
	Safety Approved	CB, CCC
	Front Panel Protection	IP65 compliant
	Operation System	Microsoft Widows XP, Windows 7, Windows XP Embedded, Ubuntu Linux
Software Compatibility		

Ordering Information

Part Number	System Built-in CPU	Description
VP-7806-R1N13A1	1.3GHz Nano™	1.3GHz Nano™ CPU Based Fanless 6.5" Touch Panel PC, with VGA, LVDS, 4 x USB 2.0, 4 x COM, 2 x GbE, Microphone, 2 Mega Pixels Camera, Left/Right Speakers, DC-in 7~36V

Optional Accessories

External AC-to-DC Adapter and Power Cable

Part Number	Description
99G63-020186	AC-to-DC adapter, DC 19V/90W with 2-pole Phoenix power plug
99G33-02058C	Power cable, 180 cm, USA type
99G33-02057C	Power cable, 180 cm, Europe type

Embedded OS (Only available for T-Parts OEM service)

Part Number	Description
POS-MXPELI-ENS04	Windows XP Embedded SP3 OS image and license, English version
VOS-UMELXI-ENS04	Linux, MID Edition, OS image only, English Version

Certificated RAM Module, Flash Disk, and 2.5" Hard Disk Drive

Part Number	Description
99G06-010408	2GB DDR2 667MHz, 128Mx8 SDRAM SODIMM, industrial grade, for using at environmental temperature up to 50°C
99G06-010398	1GB DDR2 667MHz, 128Mx8 SDRAM SODIMM, industrial grade, for using at environmental temperature up to 50°C
99G06-010338	1GB DDR2 667MHz, 64Mx8 SDRAM SODIMM, industrial grade, Tc of 0 ~ 85°C
99G61-060011	1GB Compact Flash Disk, industrial grade, -40°C ~ 85°C
99G61-060021	2GB Compact Flash Disk, industrial grade, -40°C ~ 85°C
99G61-060031	4GB Compact Flash Disk, Innodisk, industrial grade, -40°C ~ 85°C
99G61-020114	250GB, Fujitsu 2.5" SATA HDD 5400RPM

Dimensions

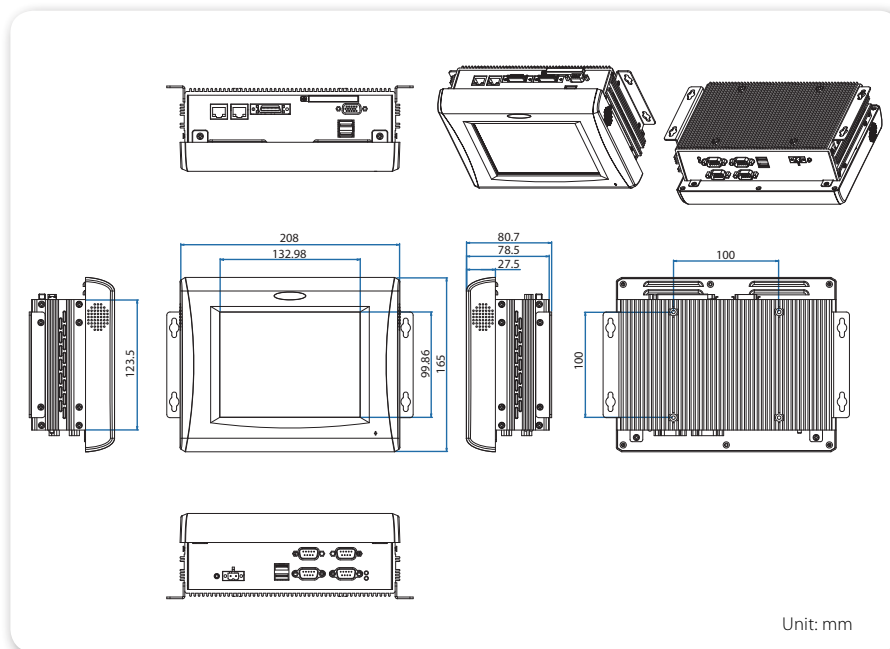

Packing List

- 1 x VP-7806 unit
- 1 x Driver & Utility CD disk
- 2 x Wall-mount bracket
- 2 x Panel-mount bracket
- 1 x Power cable, 2-pole Phoenix plug to DC-Jack
- 1 x Tube of Syringe with 0.5cc thermally conductive dispensable gel