

Datasheet

SPDT Toggle Switch On-On, PCB

RS Stock number [401-686](#)

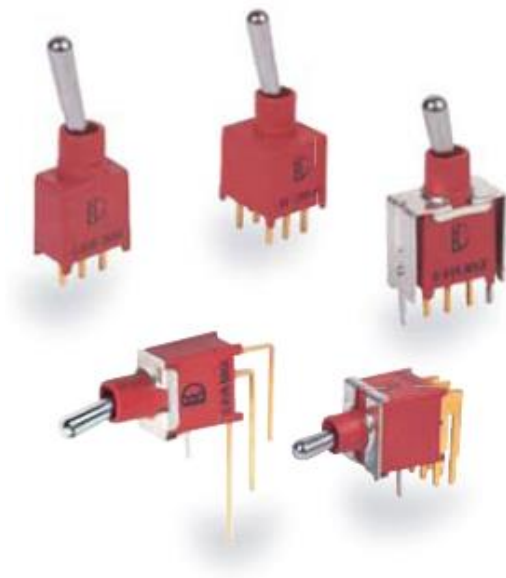

SPECIFICATIONS

CONTACT RATING: Dependent upon contact material

MECHANICAL LIFE: 30,000 make-and-break cycles.

CONTACT RESISTANCE: 20 m Ω max. initial @ 2-4VDC

100mA for both silver and gold plated contacts.

INSULATION RESISTANCE: 1,000 M Ω min.

DIELECTRIC STRENGTH: 1,000 Vrms min.@sea level.

OPERATING TEMPERATURE: -30°C to 85°C.

MATERIALS

CASE & BUSHING: Glass filled nylon 6/6, flame retardant,
heat stabilized (UL94v-0).

ACTUATOR: Brass, chrome plated, internal O-ring seal.

Standard for all actuators.

SWITCH SUPPORT: Brass, tin plated.

CONTACT / TERMINALS: Copper alloy with Silver or gold plated.

SWITCH FUNCTION

NO. POLES	UL/CSA MODEL NO.	MODEL NO.	SWITCH FUNCTION			CONNECTED TERMINALS / SCHEMATIC		
			POS.1	POS.2	POS.3	POS.1	POS.2	POS.3
SP	Q22A11	2AS1	ON	NONE	ON	2-3	N/A	2-1
	Q22A12	2AS2	ON	NONE	MOM			
	Q22A13	2AS3	ON	OFF	ON			
	Q22A14	2AS4	MOM	OFF	MOM		OPEN	
	Q22A15	2AS5	ON	OFF	MOM			
	Q22A16	2AS6	OFF	NONE	ON	OPEN		
DP	Q22A21	2AD1	ON	NONE	ON	2-3,5-6	N/A	2-1,5-4
	Q22A22	2AD2	ON	NONE	MOM			
	Q22A23	2AD3	ON	OFF	ON		OPEN	
	▲ Q22A26	2AD6	ON	ON	ON	2-3,5-6		

MOM=MOMENTARY

▲ Please check the availability in advance before order

POLE OPTIONS

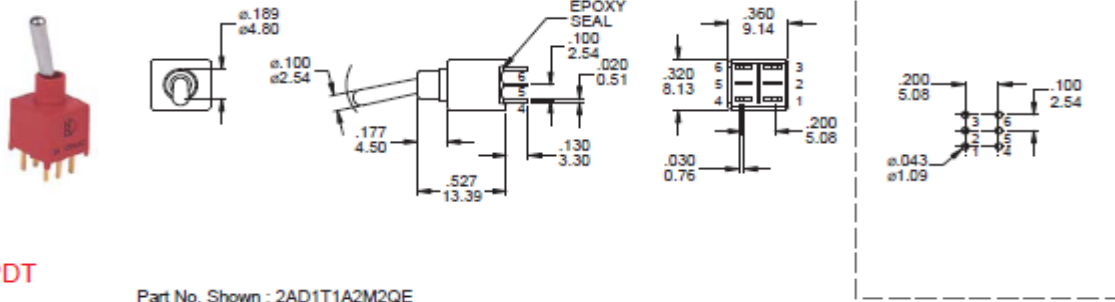
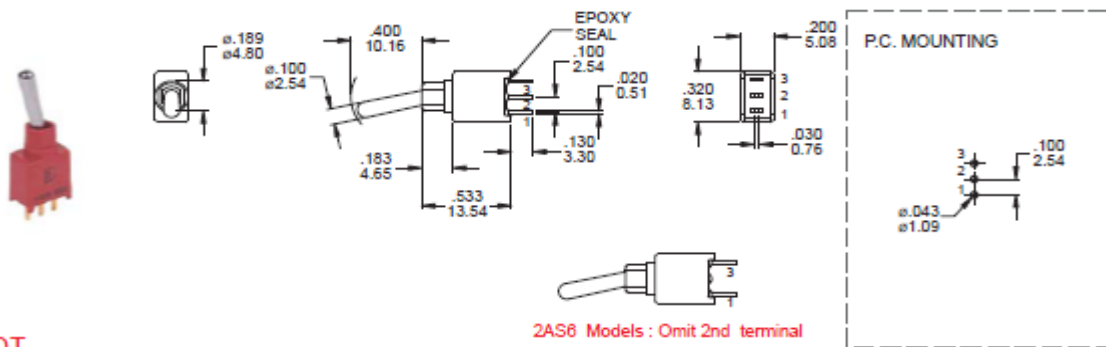

ACTUATOR OPTIONS

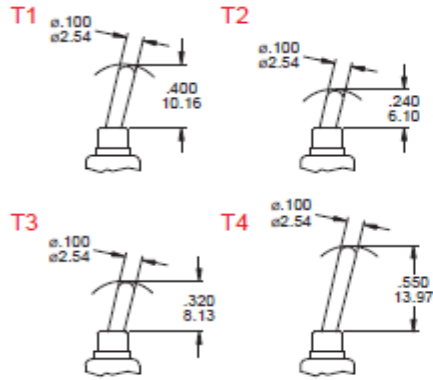

Actuator shown with A1 Bushing, sub .020 (0.50) for A3 Bushing.

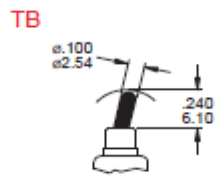
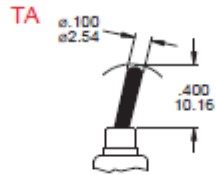

ESD
PLASTIC ACTUATOR

BUSHING OPTIONS

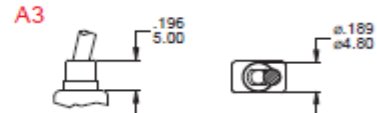
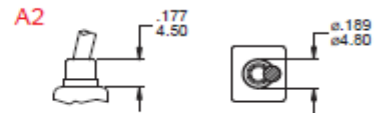
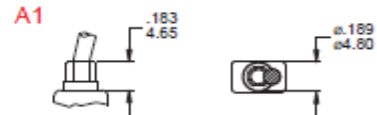

A1, A3 FOR SPDT / A2 FOR DPDT

TERMINATION OPTIONS

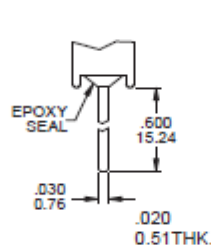
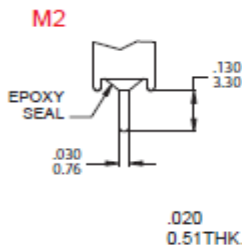

OTHER TERMINATION OPTIONS

- M6 RIGHT ANGLE P.C. MOUNT
- M6N RIGHT ANGLE P.C. MOUNT
SNAP-IN BRACKET
- M7 RIGHT ANGLE P.C. MOUNT
- VS2 VERTICAL BRACKET P.C. MOUNT

M6

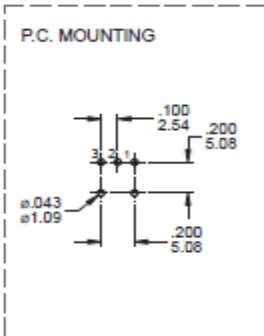
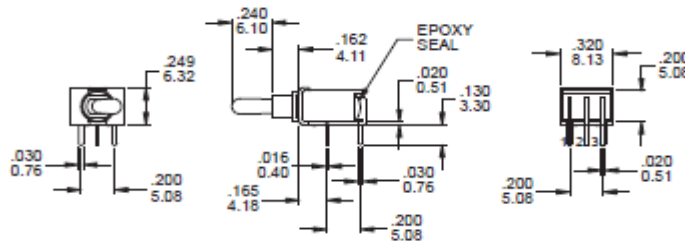

SPDT

Part No. Shown : 2AS1T2A1M6QE

M6

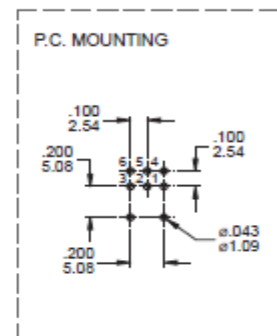
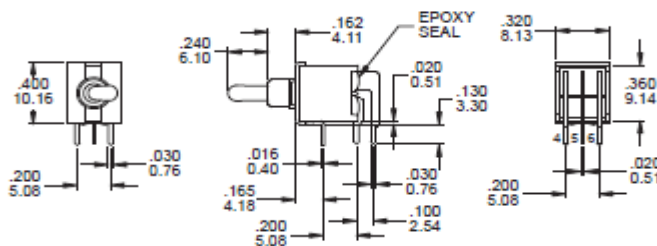

DPDT

Part No. Shown : 2AD1T2A2M6RE

M7

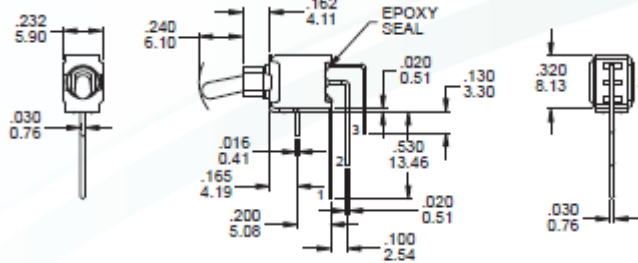

P.C. MOUNTING

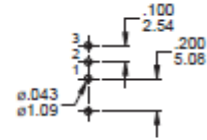

SPDT

Part No. Shown : 2AS1T2A1M7RE

M7

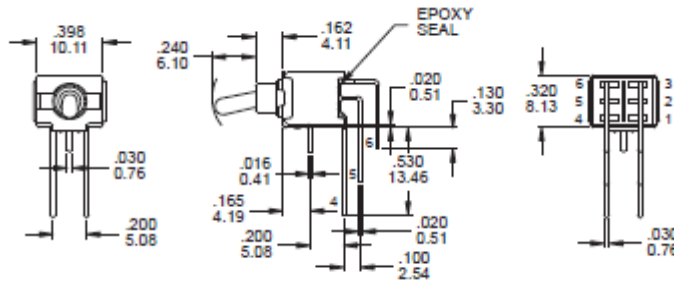

P.C. MOUNTING

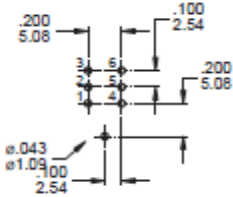

DPDT

Part No. Shown : 2AD1T2A2M7QE

VS2

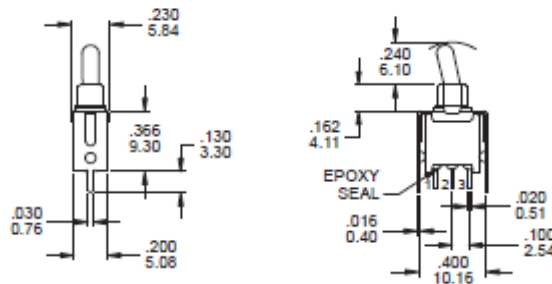

P.C. MOUNTING

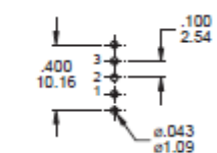

SPDT

Part No. Shown : 2AS1T2A1VS2RE

VS2

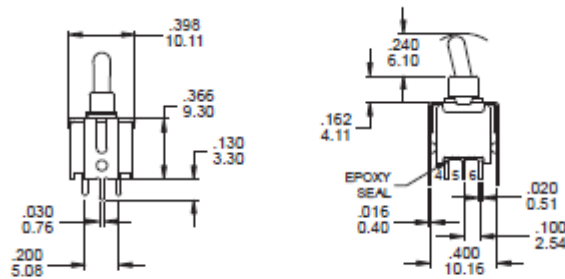

P.C. MOUNTING

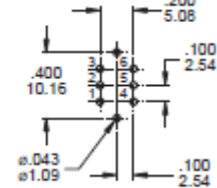

DPDT

Part No. Shown : 2AD1T2A2VS2QE

SNAP-IN TERMINATION OPTIONS

M6N



M7N

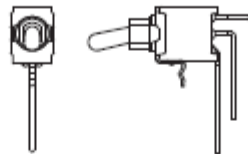

V2N

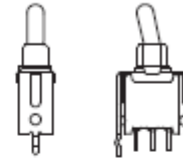

CONTACT MATERIAL OPTIONS

	CONTACT PLATING	TERMINAL PLATING	RATINGS
Q	Silver	Q = Gold flash over silver	3 Amps with resistant load @ 120VAC or 28VDC 1 Amps with resistant load @ 250VAC
S		S = Gold flash over silver,pure - tin	
C	Gold over Silver	C = Gold over silver	
K		K = Gold over silver,pure - tin	
R	Gold	R = Gold	0.4 Volt - Amps (VA) max. @ 20V max. (AC or DC)
G		G = Gold,pure - tin	

SOLDERING PROCESSES

MANUAL SOLDERING: Use soldering iron of 30 watts, controlled at 350°C approximately 5 seconds while applying solder.

WAVE SOLDERING: Recommended Soldering Temperature: 260 ± 5°C
Duration of Solder Immersion: Max 5 sec. (PCB is 1.6mm in thickness)