

Compact Lubricator - P32

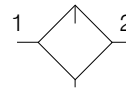

Symbols



- Integral 1/4, 3/8 or 1/2 ports (BSPP & NPT)
- Robust but lightweight aluminium construction
- Proportional oil delivery over a wide range of air flows.
- Finger tip ratchet control for precise oil drip rate adjustment
- Fill from top under system pressure

Options:

<b>P 3 2</b>	<b>L A</b>			<b>L</b>		<b>N</b>	<b>N</b>
<b>Thread type</b>		<b>Port size</b>		<b>Bowl type</b>		<b>Mounting</b>	
BSPP	<b>1</b>	1/4	<b>2</b>	Poly bowl with bowl guard	<b>G</b>	No bracket	<b>N</b>
NPT	<b>9</b>	3/8	<b>3</b>	Metal bowl with sight glass	<b>S</b>		
		1/2	<b>4</b>				
<b>Type</b>				<b>Drain type</b>			
Oil mist standard sight dome				No drain; closed end			
				<b>L</b>			<b>N</b>

Port size	Description	Order Code	Flow dm <sup>3</sup> /s (scfm)	Max bar (psi)	Height mm (Inches)	Width mm (Inches)	Depth mm (Inches)
1/4"	Poly bowl - No drain	<b>P32LA12LGNN</b>	18 (38)	10 (150)	211 (8.3)	60 (2.36)	60 (2.36)
1/4"	Metal bowl - No drain	<b>P32LA12LSNN</b>	18 (38)	17 (250)	211 (8.3)	60 (2.36)	60 (2.36)
3/8"	Poly bowl - No drain	<b>P32LA13LGNN</b>	32 (68)	10 (150)	211 (8.3)	60 (2.36)	60 (2.36)
3/8"	Metal bowl - No drain	<b>P32LA13LSNN</b>	32 (68)	17 (250)	211 (8.3)	60 (2.36)	60 (2.36)
1/2"	Poly bowl - No drain	<b>P32LA14LGNN</b>	47 (100)	10 (150)	211 (8.3)	60 (2.36)	60 (2.36)
1/2"	Metal bowl - No drain	<b>P32LA14LSNN</b>	47 (100)	17 (250)	211 (8.3)	60 (2.36)	60 (2.36)

\* flow with 6.3 bar (91.3 psig) inlet pressure and 0.5 (7.2 psig) pressure drop.

## Specifications

Flow Capacity*	1/4	18 dm <sup>3</sup> /s (38 scfm)
	3/8	32 dm <sup>3</sup> /s (68 scfm)
	1/2	47 dm <sup>3</sup> /s (100 scfm)
Operating Temperature	Plastic Bowl	-10°C (14°F) to 52°C (125°F)
	Metal Bowl	-10°C (14°F) to 65.5°C (150°F)
Max Supply Pressure	Plastic Bowl	10 bar (150 psi)
	Metal Bowl	17 bar (250 psi)
Useful Retention		121 cm <sup>3</sup> (4.09 US oz.)
Port Size	BSPP / NPT	1/4, 3/8, 1/2
Weight		0.31 kg (0.68 lbs)

\*Inlet pressure 6.3 bar. Pressure drop 0.5 bar.

## Materials of Construction

Body	Aluminium	
Body Cap	ABS	
Bowls	Plastic Bowl	Polycarbonate
	Metal Bowl	Aluminium
Seals	Plastic Bowl	Nitrile
	Metal Bowl	Nitrile
Sight Dome	Polycarbonate	
Sight Gauge	Metal Bowl	Polycarbonate
Suggested Lubricant	ISO / ASTM VG32	
Pick-up Filter	Sintered Bronze	

## Dimensions

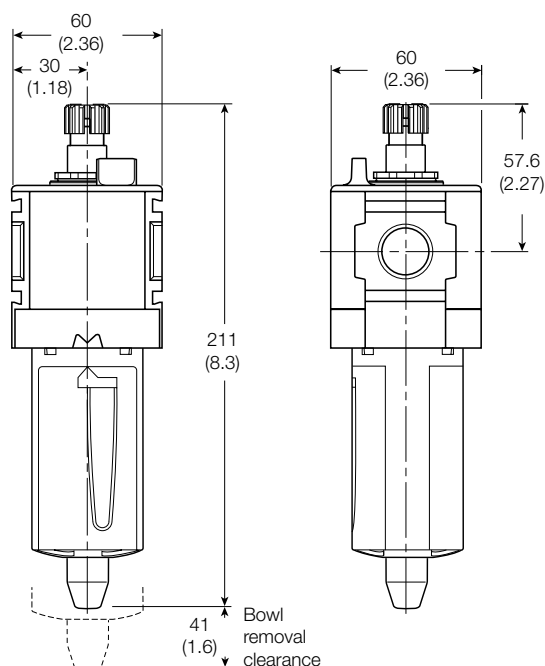

## Flow Charts

### 1/4 Lubricator

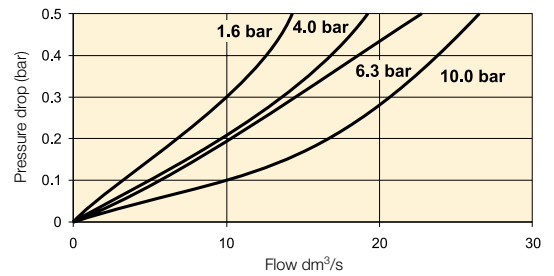

### 3/8 Lubricator

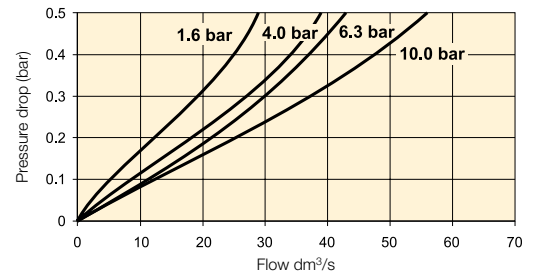

### 1/2 Lubricator

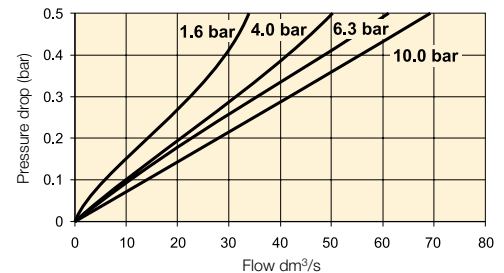

## Repair and Service Kits

Plastic bowl / Bowl guard no drain	<b>P32KA00BGN</b>
Metal bowl / Sight gauge no drain	<b>P32KA00BSN</b>
Drip control assembly	<b>P32KA00PG</b>
L-Bracket (fits to body)	<b>P32KA00ML</b>
T-Bracket (fits to body connector)	<b>P32KA00MB</b>
T-Bracket with body connector	<b>P32KA00MT</b>
Body connector	<b>P32KA00CB</b>
Lubricator Oil - VG15:ISO 3448 - 100ml	<b>P3XKA00PPA</b>
Lubricator Oil - VG32 - 1 litre	<b>P3YKA00PPBB</b>