

# KR 47 PPA

## Dimensions

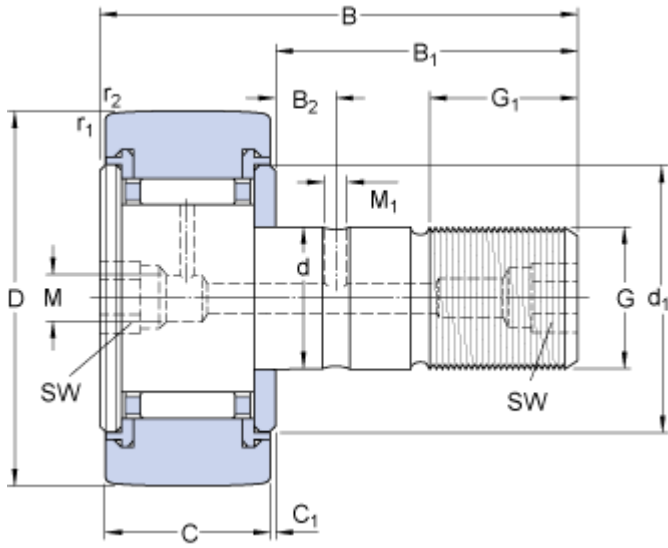

|           |          |    |
|-----------|----------|----|
| D         | 47       | mm |
| d         | 20       | mm |
| B         | 66       | mm |
| C         | 24       | mm |
| $B_1$     | 40.5     | mm |
| $B_2$     | 9        | mm |
| $C_1$     | 0.8      | mm |
| $d_1$     | 36.5     | mm |
| G         | M 20x1.5 |    |
| $G_1$     | 21       | mm |
| M         | 6        | mm |
| $M_1$     | 4        | mm |
| SW        | 10       | mm |
| $r_{1,2}$ | min. 1   | mm |

## Calculation data

|                                |          |      |       |
|--------------------------------|----------|------|-------|
| Basic dynamic load rating      | C        | 14.7 | kN    |
| Basic static basic load rating | $C_0$    | 24.5 | kN    |
| Fatigue load limit             | $P_u$    | 2.9  | kN    |
| Maximum dynamic radial loads   | $F_r$    | 23.6 | kN    |
| Maximum static radial loads    | $F_{0r}$ | 33.5 | kN    |
| Limiting speed                 |          | 3000 | r/min |

## Mass

|                   |       |    |
|-------------------|-------|----|
| Mass cam follower | 0.381 | kg |
|-------------------|-------|----|

## Mounting information

|                               |     |     |
|-------------------------------|-----|-----|
| Recommended tightening torque | 120 | N·m |
|-------------------------------|-----|-----|

## Appertaining products

Grease fitting

NIP A2x7.5

Hexagonal nut

M 20x1.5

**Appropriate products**

---

Lubrication adapter

AP 10