

FEMALE END VIEW

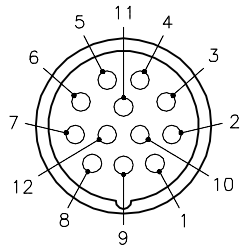

- 1 = BROWN
- 2 = ORANGE
- 3 = BLUE
- 4 = WHITE
- 5 = GREEN
- 6 = YELLOW
- 7 = GRAY
- 8 = PINK
- 9 = RED
- 10 = BLACK
- 11 = VIOLET
- 12 = GREEN/YELLOW

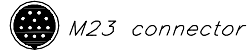

PANEL CUTOUT (TYPICAL)

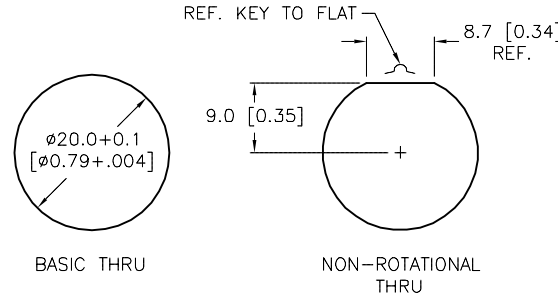

SPECIFICATIONS

CONTACT CARRIER MATERIAL	NYLON or PBT
CONTACT MATERIAL/PLATING	BRASS/GOLD
CONNECTOR HOUSING MATERIAL/PLATING	BRASS/NICKEL
O-RING/GASKET MATERIAL	RUBBER (NBR or FPM)
RATED CURRENT [A]	6.0 A
RATED VOLTAGE [V]	300 V
CONDUCTOR INSULATION MATERIAL	PVC
NUMBER OF CONDUCTORS (AWG)	12x18 AWG
TEMPERATURE	-40°C TO +105°C (-40°F TO +221°F)
PROTECTION CLASS	MEETS IEC IP67
MAXIMUM PANEL THICKNESS	3.5 [0.138]

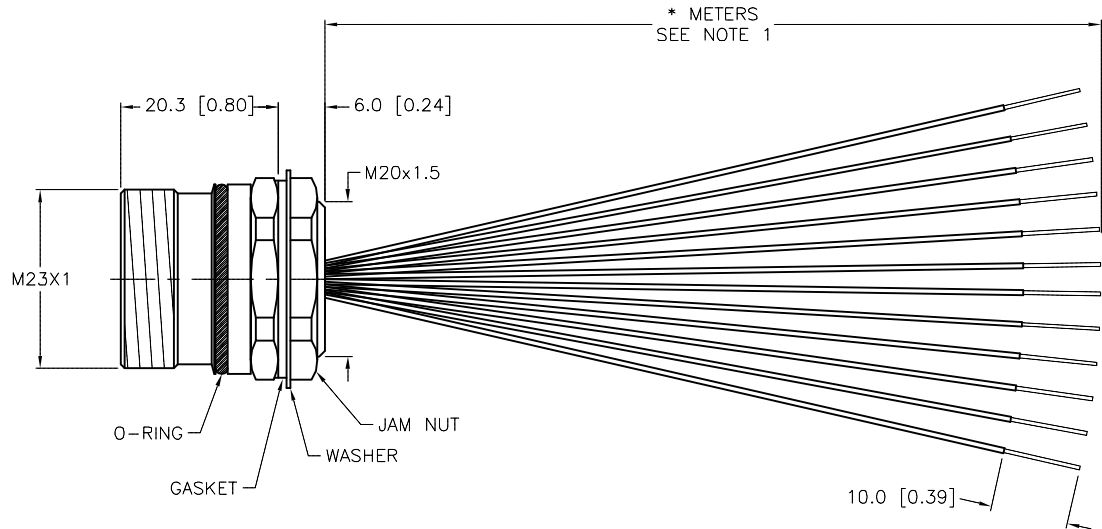
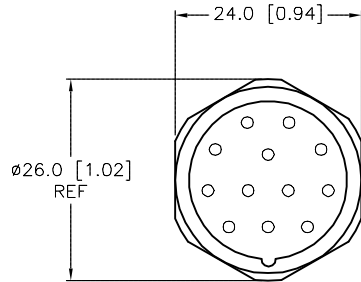

CABLE LENGTH	TOLERANCE*
ALL LENGTHS	+ 4% (OR 50mm) OF LENGTH - 0% (OR 0mm) OF LENGTH WHICHEVER IS GREATER
STRIP LENGTH	TOLERANCE*
0-7mm	±0.5mm
8-29mm	±1.0mm
30-49mm	±2.0mm
50-69mm	±3.0mm
70-100mm	±4.0mm
OVER 100mm	±5.0mm

\* UNLESS OTHERWISE SPECIFIED

NOTES:  
1."\*" INDICATES LEAD LENGTH IN METERS. CONTACT TURCK TO ORDER SPECIFIC LENGTHS.

SOURCE DRAWING - FOR REFERENCE ONLY

RELATED DOCUMENTS 1. 2. 3. 4.	3RD ANGLE PROJECTION 	THIS DRAWING IS CONFIDENTIAL AND THE PROPERTY OF TURCK INC. USE OF THIS DOCUMENT WITHOUT WRITTEN PERMISSION IS PROHIBITED.		3000 CAMPUS DRIVE MINNEAPOLIS, MN 55441 1-800-544-7769 (763) 553-7300 (763) 553-0708 fax turck.com	
		DRFT	RDS	DATE 07/03/03	DESCRIPTION CKF 12-12-*
MATERIAL SEE SPECIFICATIONS	ALL DIMENSIONS DISPLAYED ON THIS DRAWING ARE FOR REFERENCE ONLY	APVD	SCALE 1=1.0	IDENTIFICATION NO.	
FINISH SEE SPECIFICATIONS		UNIT OF MEASUREMENT <b>MILLIMETER [ INCH ]</b>		REV C	
DO NOT SCALE THIS DRAWING		FILE: 777005431		SHEET 1 OF 1	

C	UPDATE SPECIFICATIONS	NF	12/11/14	48161
REV	DESCRIPTION	BY	DATE	ECO NO.