



M2M

The measure of efficiency

The importance of control

Measurement and advanced analysis of electrical parameters

To make equipment as efficient as possible, it is essential to know the details of its behaviour and consumption. This allows energy losses to be identified and eliminated as well as optimising the use of electricity. It is possible to perform more efficiently, starting with measuring the electrical parameters.

The new M2M network analyser has advanced analysis functions which allow effective measurement of the main single-phase or three-phase electrical parameters: voltage, current, frequency, power factor, active and reactive power, active and reactive energy.

Fitted to low- and medium-voltage electrical panels, the new analyser allows the measurement and analysis in real time of electrical parameters, also verifying the quality of the energy thanks to THD measurement.

M2M also keeps the system's consumption under control, giving figures in CO₂ kg and Euros to ensure more efficient and rational use of energy. Bidirectional metering of energy and power on the 4 quadrants allows both production and consumption of energy to be monitored with a single device.

Aside from optimising the use of loads, real time measurement contributes to containing both environmental and budgetary impact.

All information gathered by the analyser can be transmitted quickly to remote locations through specific communication interfaces – RS485 or RJ45, with the support of numerous protocols including Modbus RTU, Modbus TCP/IP and Profibus DP.

Interaction with the control and supervision systems is possible via different inputs and outputs, all programmable.



The value of flexibility

Versatility in its different applications and completeness of functions

With the new front-panel M2M network analysers, ABB offers the solution for measuring and analysing electrical parameters for all distribution systems, both low- and medium-voltage, single-phase or three-phase with or without neutral.

Fixing clips which ensure the device is held reliably on the front-panel, making it immune to vibrations and temperature fluctuations

Auxiliary multi-voltage power supply, from 24 V DC to 230 V AC

Real time display of energy consumption also in Euros and kg CO₂



Multilingual backlit display with two lines of scrolling text to guide and help the user in reading data and programming. Safety password for protecting settings

Communication without limits thanks to the availability of different protocols for all types of network and programmable analogue and digital inputs/outputs

Reduced depth: only 57 mm inside the panel. Ease of cabling guaranteed by removable terminals

Intuitive and easy-to-use front keypad for navigating screens and configuring the device. IP50 protection on the front case

M2M

The measure of energy efficiency

Monitoring and optimisation of consumption thanks to unique technological characteristics and solutions.



Display of produced and consumed energy in CO₂ kg



Display of produced and consumed energy in Euros

With the M2M analyser it is possible to keep the **electrical consumption** of all types of system under control, measuring them in real time both in economic and environmental impact terms, thanks to the **immediate conversion into Euros and CO₂ kg**.

Bidirectional reading allows the amount of produced and consumed energy, saved money and avoided pollution to be displayed, optimal in systems generating energy from renewable sources.

In industrial systems where energy consumption is relevant, monitoring of absorbed power by measuring maximum demand is indispensable to avoid paying penalties to the electricity distributor.

Added to this is the possibility of keeping the quality of electrical parameters under control, with positive results on safety and operating costs.



The advantages of communication

Intuitive analyser with multiple integrated functions, which communicates also via digital and analogue I/O

The integration of electrical consumption measurement in a supervision system allows 360° analysis of system performances, anticipating malfunctions and wasted energy as well as bad management of loads.

This device is able to transmit all measured parameters via the most advanced communication protocols, facilitating its integration into **Modbus RTU**, **Modbus TCP/IP** and **Profibus DP networks**.

For interaction with control and supervision systems are available **digital pulse outputs** to remotely control active and reactive energy consumption, **digital outputs** programmable as threshold alarms with activation delay and return hysteresis, **relay outputs** with nominal current up to 16 A, and **analogue outputs** with programmable span (0 - 20 mA or 4 - 20 mA) for remoting status and events.

Digital inputs allow pulse acquisition from other energy counters or users. Using the digital input it is possible to synchronise energy metering between multiple meters connected in a network or with the utility meter. To facilitate maintenance operations, there is a countdown timer of the system operating time activated upon achievement of a programmable threshold value of total current. Upon expiry of the set period an icon will appear on the display. A further count-up timer keeps track of the device's working time.



M2M: Made to Measure Easy to install

The reduced depth inside the panel – only 57 mm – makes installing the analyser on the panel simple, even with reduced space.

The **removable terminals**, accessible from three sides, along with wiring parallel to the panel guarantee ease of installation. The amperometric measurement circuits are fastened with screws to ensure safety and operating precision. The fixing system allows the device to be installed safely and reliably on the panel, not only upon installation but also during the working period when the unit is subject to vibrations and temperature fluctuations. The network analyser performs constant verification of correct

wiring thanks to its **autodiagnostic function**, signalling any operating errors: check of voltages and currents sequence, check of consistency between wiring and set configuration, check of uniformity of current signs.

The new network analyser's compact dimensions are one of its key features. At only 96 mm x 96 mm x 77 mm – coupled with **the reduced depth inside the panel of only 57 mm** – it still contains everything necessary to measure power quality parameters in real time.

The reduced depth of only 57 mm makes the analyser ideal for installation even in panels with reduced space. The removable terminal boxes facilitate assembling, while the screw fastenings of the amperometric measurement circuits offer reliability and precision.

The front case offers IP 50 protection and is fitted with navigation buttons and a **backlit multilingual display**. The **two scrolling lines of text** allow even the least prepared user to easily program the device and correctly understand and interpret the displayed parameters.



M2M: Made to Measure

Ease of use

The display provides the user with clear indications which guide him both to make settings and to understand and interpret the displayed values correctly, thanks to the two lines of scrolling text in the user's language.

The display's white background makes it easy to be read in any lighting condition.

The backlight is also adjustable, with an **energy-saving** function which automatically switches off the backlight after three minutes of keypad inactivity.

The intuitive and easy-to-use front keypad simplifies navigation of the screens and configuration of the device.

The possibility to set a **safety password** prevents unauthorised personnel from making changes to the settings.

The device is supplied with an installation manual, mini CD with technical documentation regarding the device and communication protocols.



Questions and answers

Technical details on the M2M measuring device

Question: Is it possible to install M2M in a Modbus RTU network with ANR and/or DMTME already installed?

Answer: Yes, it is possible, as the M2M analyser's Modbus RTU protocol is compatible with that of the other measuring devices. It is also compatible with all equipment fitted with a Modbus RTU serial output.

Modbus protocol compatibility is guaranteed by the ability to set all communication parameters: communication speed (baud rate), parity number and stop bit.

Q: What is the difference between $\cos\varphi$ and power factor?

A: $\cos\varphi$ is the displacement angle between the voltage and current in an alternating current electrical system. In a purely resistive system, the phase displacement is zero and $\cos\varphi$ is equal to 1. The Power Factor is the ratio between the active power and the apparent power. In the presence of power lines with harmonic content it is necessary to talk of Power Factor in that the harmonic effect is also considered in the ratio. For non-sinusoidal operations it therefore makes sense to talk about the power factor as opposed to $\cos\varphi$.

Q: Direct and indirect measurements: how do you set the correct transformation ratio?

A: The direct connection to the line defines a direct measurement of the size, since the device is connected to the measurement point without the interposition of adapters. The direct measurement is only possible when the size to measure has a level within the capacity of the device. When the size to be measured is larger than the capacity of the measuring device, it is necessary to interpose a transformer that reduces the size and supplies the device with values compatible with its capacity. The reading implemented through a measurement transformer is defined as indirect measurement, because it does not occur directly on the line examined.

All digital multifunction devices require an indirect insertion through CT current transformers and, sometimes, with VT voltage transformers. The main measurement parameters to set up are the transformation ratios of the CT and the VT, defined as a mathematical ratio between nominal value and secondary value; for example, setting the transformation ratio (kCT) of a CT CT3/100 with secondary at 5 A means setting $kCT = 100 / 5 = 20$.

Q: What does total harmonic distortion mean, measured and displayed on the device as THD?

A: The harmonics are sinusoidal waves with frequency equal to whole multiples of the fundamental wave. Non-linear loads are sources of current harmonics. The current harmonics interact with the impedance of the distribution system, creating voltage distortions and energy losses.

THD, Total Harmonic Distortion, is the total harmonic distortion of the fundamental wave, considering the contribution of all the harmonic components present. THD is expressed as a percentage with respect to the fundamental wave and is a valid indicator of the presence of harmonic disturbances in the network.

Q: Is it possible to view energy counts in CO₂ kg and Euros on the M2M analyser after setting them in the conversion factors setup menu? How are the conversions defined and where can they be found?

A: The CO₂ emissions avoided are an indicator of environmental benefits deriving from the mix of resources used during generation and the efficiency which accompanies these phases from their use up to use of the finished products.

As such the correct value of the energy conversion factor depends on the mix of energy sources used for generating the electricity. This value is listed on electricity bills; the power company must specify how much electricity has been produced using different energy sources.

The Euro conversion is also clearly listed on the bill in order to put a value on electricity consumption. If, on the other hand, you need to put a monetary value on the electricity produced by the system, this depends on the state incentives in force based on type of system.

The following default values are memorised in the device upon installation: 0.18€/kWh and 0.15 CO₂ kg/kWh.

M2M

Technical features

Auxiliary power supply

Voltage range	[V]	From 24 to 240 V AC/DC From 48 to 240 V AC/DC M2M I/O From 24 to 240 V DC and from 48 to 240 V AC M2M ETHERNET, M2M PROFIBUS
Frequency range	[Hz]	45 - 65
Protection fuse		T 0.5 A from 24 V to 100 V T 0.25 A from 100 V to 240 V

Power consumption

	[VA]	7 max
--	------	-------

Measurement type

		Sampling TRMS
--	--	---------------

Measurement accuracy

Voltage		±0.5% F.S. ±1 digit
Current		±0.5% F.S. ±1 digit
Frequency		40.0 - 99.9 Hz: ± 0,2% ± 0,1 100 - 500 Hz: ± 0.2% ± 1
Power factor		± 1% ± 1 digit (from $\cos\varphi=0.3$ Inductive to $\cos\varphi=0.3$ Capacitive)
Active power		± 1% ± 0.1% F.S (from $\cos\varphi=0.3$ Inductive to $\cos\varphi=0.3$ Capacitive)
Active energy		Class 1

Measurement range

Voltage	[V]	From 10 to 500 approx. TRMS VL-N. No decimal places
Current		From 50 mA to 5 A TRMS 2 decimal places displayed
Frequency	[Hz]	From 40 to 500 1 decimal place displayed up to 99,9 and in integers above 100
Power factor		2 decimal places displayed

Installation

Distribution networks		Low and medium voltage Low voltage M2M LV, M2M LV MODBUS Single-phase connection Three-phase with neutral - Three-phase without neutral
Current inputs	[A]	Always use external CT Primary from 1 to 10,000 A AC approx. Secondary 5 A and 1 A AC approx. N.B.: in case of CT secondary at 1 A the accuracy class is reduced to 2.5% F.S. ±1 digit, in the range 5-100% F.S.
Voltage inputs	[V]	Direct insertion up to 500 AC approx. Indirect insertion with VT: Primary from 60 to 60,000 V AC approx - secondary from 60 to 190 V AC N.B.: In case of VT secondary at less than 100 V the accuracy class is reduced to 2.5% F.S. ±1 digit, in the range 5-100% F.S.
Protection fuse for voltage inputs	[A]	0.1

Data update frequency

		2 times/second
--	--	----------------

M2M

Technical features

Harmonic distortion count	[Hz]	Band measurement up to 500
----------------------------------	------	----------------------------

Energy measurement

Single-phase maximum value counted		10 GWh / GVarh / GVAh
Three-phase maximum value counted		30 GWh / GVarh / GVAh
Energy balance maximum value counted		10 GWh / GVarh / GVAh with sign
Input pulses maximum energy value counted		40 GWh / GVarh

Terminal characteristics

Current inputs		Cross section 6 mm ² - Step 6.35 mm
Voltage inputs		Cross section 2.5 mm ² - Step 7.62 mm
Impulsive outputs		Cross section 2.5 mm ² - Step 5.08 mm
RS485 Serial port		Cross section 2.5 mm ² - Step 5.08 mm
Relay outputs		Cross section 2.5 mm ² - Step 5.08 mm

Overall dimensions		96 mm x 96 mm x 77 mm (Depth inside switchboard: 57 mm)
---------------------------	--	---

Weight	[Kg]	0.400 max
---------------	------	-----------

Standards

Overall dimensions		IEC 61554
Protection degree		IEC 60529
Accuracy class		IEC 60688, IEC 61326-1, IEC 62053-21 , IEC 62053-23, IEC 62053-31.
Electrical safety		IEC 61010-1

User interface

Display		Scrolling text in user-selectable language
Display type		LCD with backlighting which can be set by user
Display dimensions	[mm]	72x57

Communication interface

RS485 (M2M MODBUS, M2M LV MODBUS, M2M ALARM, M2M I/O)

- Protocol		Modbus RTU
- Electrical standard		RS485 with optical isolation
- Baud rate		4.8, 9.6, 19.2 kbps
- Parity number		Odd, Even, None
- Stop bit		1, 2
- Address		1-247
- Connectors		4-pole terminal (integrated 120 Ohm termination)

Profibus (M2M PROFIBUS)

- Protocol		Profibus with slave DP-V0 function in compliance with IEC 61158 regulations
- Electrical standard		RS485 with optical isolation
- Baud rate		Automatic detection [9.6 - 12 Mbps]
- LED indicators		Green for communication status and Red for communication error
- Address		0-126
- Connectors		DB 9 female connector (do not use connectors with 90° cable outlet)

Ethernet (M2M ETHERNET)

- Protocol		Modbus TCP/IP
- Connectors		RJ45

Digital output programmed as pulse

Contact supply external voltage	[V]	48 max (peak AC/DC)
Maximum current	[mA]	100 (peak AC/DC)
Pulse duration	[ms]	50 OFF (min) / 50 ON closed contact
Pulse frequency		10 pulses/s (max)

Digital output programmed as alarm

Contact supply external voltage	[V]	48 max (peak AC/DC)
Maximum current	[mA]	100 (peak AC/DC)
Alarm activation delay	[s]	1 - 900 s (programmable)
Alarm return hysteresis		0 - 40% (programmable)

Relay output (M2M ALARM)

Normal current	[A]	16 AC1 - 3 AC15
Max. instantaneous current	[A]	30
Nominal voltage	[V]	250 V AC
Max. instantaneous voltage	[V]	400 V AC
Nominal load	[VA]	4000 AC1 - 750 AC15

Analogue output (M2M I/O)

Programmable electrical parameters		Span [0 - 20 mA or 4 - 20 mA]
Load		Typical 250 Ohm, max 600 Ohm

Digital inputs (M2M I/O)

Nominal voltage	[V]	24 V DC (absorption = 13 mA)
Maximum voltage	[V]	32 V DC (absorption = 22 mA)
Max. voltage for OFF status	[V]	8 V DC
Min. voltage for ON status	[V]	18 V DC

Hour counters

Countdown timer		Countdown of system operating time with the activation of a programmable threshold on total current. Upon expiry of the maintenance period set an icon will appear on the display.
Count-up timer		Operational time of device

Climatic conditions

Storage	[°C]	from -10 to +60
Operation	[°C]	from -5 to +55
Relative humidity		Max 93% (non-condensing) at 40°C

Protection degree

Frontal		IP50
At terminals		IP25

M2M

Order codes

Type	Description	Protocol	Serial port	ABB code	Bbn 8012542 EAN
M2M	2 digital outputs programmable as threshold alarms or pulses	-	-	2CSG299883R4052	998839
M2M MODBUS	2 digital outputs programmable as threshold alarms or pulses	Modbus RTU	RS485	2CSG299893R4052	998938
M2M ETHERNET	2 digital outputs programmable as threshold alarms or pulses	Modbus TCP/IP	RJ45	2CSG299903R4052	999034
M2M PROFIBUS	2 digital outputs programmable as threshold alarms or pulses	Profibus	RS485	2CSG299913R4052	999133
M2M ALARM	2 digital outputs programmable as threshold alarms or pulses, 2 programmable relay outputs	Modbus RTU	RS485	2CSG299923R4052	999232
M2M I/O	2 digital outputs programmable as threshold alarms or pulses, 3 digital inputs and 2 analogue outputs	Modbus RTU	RS485	2CSG299933R4052	999331
M2M LV	2 digital outputs programmable as threshold alarms or pulses, suitable only for low voltage applications	-	-	2CSG299943R4052	999430
M2M LV MODBUS	2 digital outputs programmable as threshold alarms or pulses, suitable only for low voltage applications	Modbus RTU	RS485	2CSG296992R4052	969921

Installation of the M2M network analyser is completed with:

- CT current transformers and VT voltage transformers to transfer the measurement signals to the device
- E 9F fuses and E 90 fuse holder for protection of auxiliary power supply and voltage inputs
- CP-D power supplies for 24V DC auxiliary power supply
- TS-C, TM-S and TM-C transformers for AC auxiliary power supply

M2M

Overall dimensions

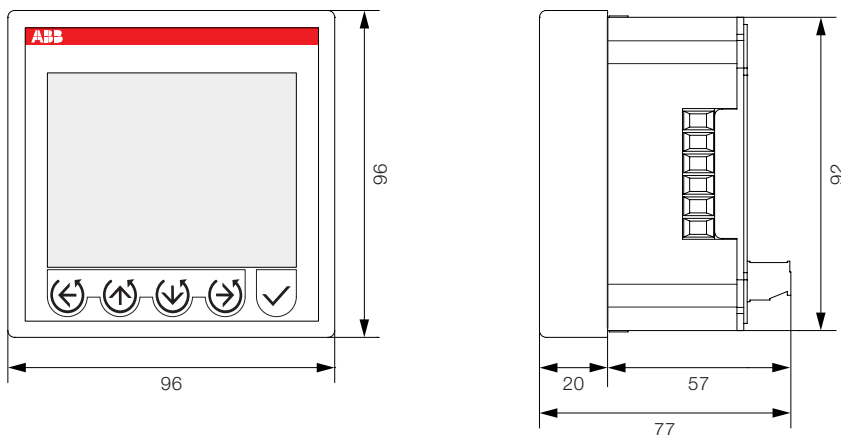

M2M

Wiring diagrams

Measurement input and auxiliary power supply connections

Three-phase + neutral with 3 CT

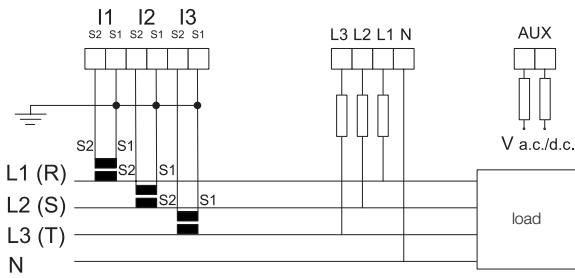

Three-phase with 3 CT

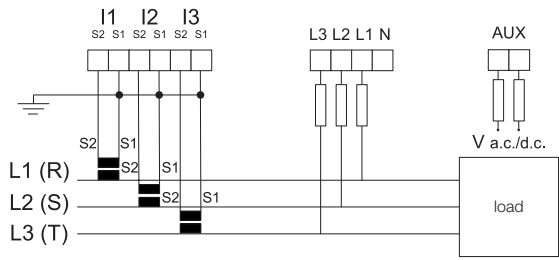

Three-phase + neutral with 3 CT and 3 VT

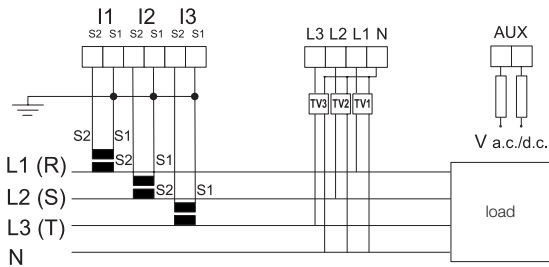

ARON Three-phase with 2 CT and 2 VT

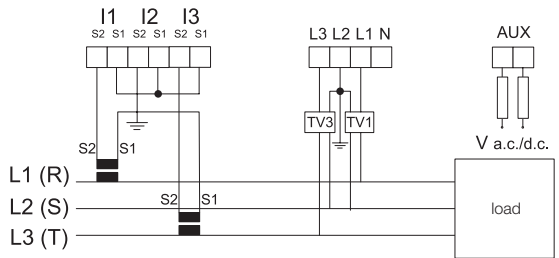

Not suitable for the M2M LV and M2M LV MODBUS models.

Single-phase with 1 CT

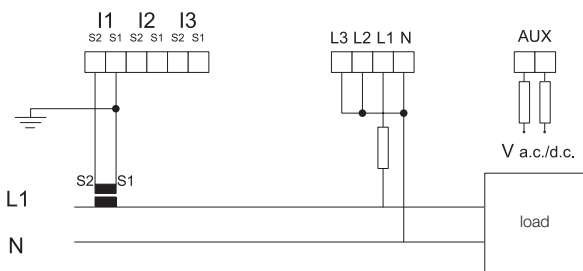

Balanced three-phase with 1 CT

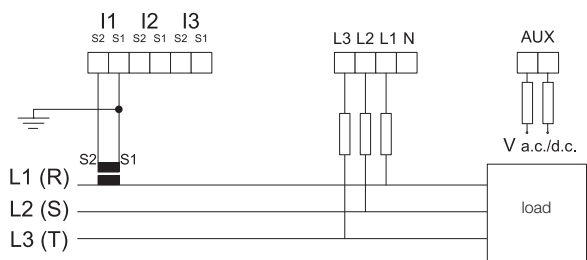

M2M

Wiring diagrams

Analogue and digital output connections, digital inputs

Digital outputs as alarms with external relay for control of loads

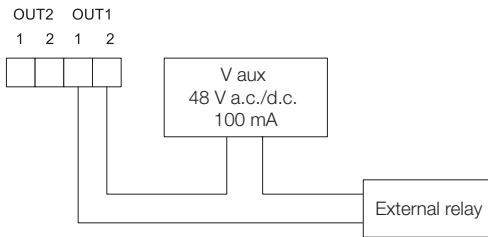

Digital outputs as pulses

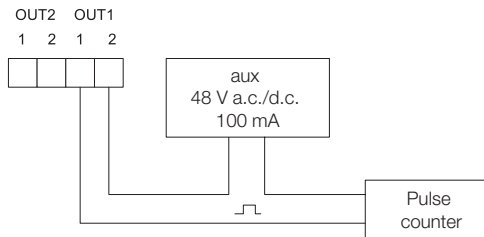

M2M ALARM electromechanical relay outputs

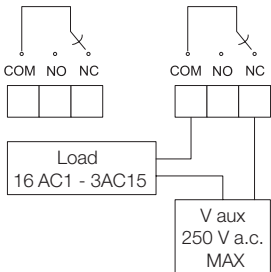

M2M I/O digital inputs (example in NPN mode)

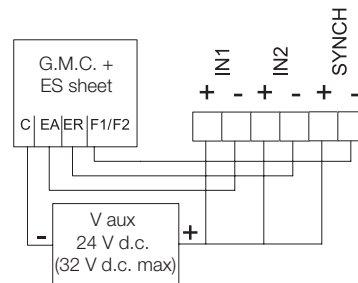

M2M I/O analogue outputs

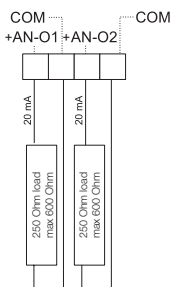

Install the free QRCode reader application on your mobile.
Use the app to scan the QRCode or take a picture of it with your mobile camera to view the instruction manual.



Can you always put a value on efficiency? Certainly.

The solution for measuring and analysing electrical parameters for all distribution systems, both low and medium voltage: the new M2M network analysers, compact and easy to install, show the energy consumed and the energy produced in a very clear way on the high visibility display expressed both in currency (Euro) as well as in kg of CO₂. To always have the effective consumption of a system under control, even remotely thanks to various communication protocols. To optimise performance and not waste energy. To reduce environmental impact and increase efficiency.

<http://www.abb.com/abblibrary/DownloadCenter/>
- 2CSC400002D0907



Contacts

ABB SACE

A division of ABB S.p.A.

Via L. Lama, 33

20099 Sesto S. Giovanni (MI) - Italy

Tel.: +39 02 2414 1

Fax: +39 02 2414 3892

www.abb.com

The data and illustrations are not binding. We reserve the right to modify the contents of this document on the basis of technical development of the products, without prior notice.

Copyright 2013 ABB. All rights reserved.

2CSC445021B0202 - 07/2013