

LV-120-230AC/110DC

Order No.: 2833738



Plug-in module, for mounting on PR1 and PR2, with varistor and yellow LED, input voltage: 120 - 230 V AC/110 V DC \pm 20%

Commercial data

EAN	 4 017918 933920
Pack	10
Customs tariff	85366990
Gross weight in pieces	2.91 g
Country of Origin	CN
Catalog page information	Page 72 (IF-2011)

Product notes

WEEE/RoHS-compliant since:
01/03/2006

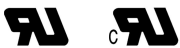

Please note that the data given here has been taken from the online catalog. For comprehensive information and data, please refer to the user documentation at <http://www.download.phoenixcontact.com>. The General Terms and Conditions of Use apply to Internet downloads.

Certificates

Certification

cULus Recognized

Certifications applied for:

Certification Ex:

Drawings

Circuit diagram

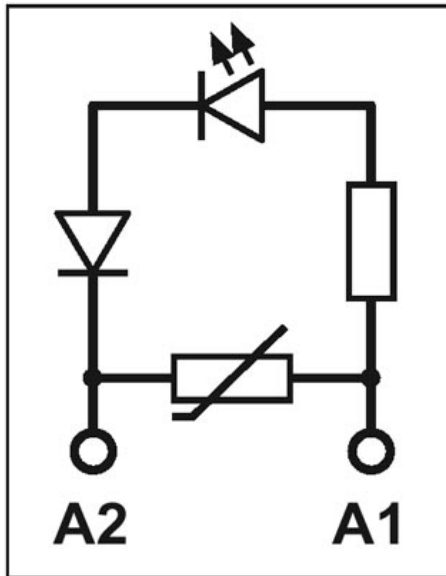

Address

PHOENIX CONTACT Ltd
Halesfield 13
Telford / Shropshire / TF7 4PG, England
Phone 01952 681 700
Fax 01952 681 799
<http://www.phoenixcontact.co.uk>



Phoenix Contact Ltd.
Technical modifications reserved;