

Panel Mount "Hockey Puck" Relays and DIN Rail Mounted Solid State Relays up to 120 Amps



With forty years of experience, Gefran is the world leader in the design and production of solutions for measuring, controlling, and driving industrial production processes. Gefran's know-how and experience guarantee continuity and tangible solutions. Gefran's line of solid state relays are the ideal solution for applications where high speed switching and long life are essential. In specific applications, solid state relays offer many advantages over electromechanical devices including no moving parts or contact arcing. In addition, solid state relays are directly compatible with logic components such as microprocessors and PLCs.

leakage. This feature is important in certain medical, residential and industrial applications. The Gefran solid state relays also include built-in metal oxide varistor (MOV) protection to protect against internal damage to the solid state relay.

Output Circuit Features

The Gefran solid state relays feature zero voltage turn-on, which means they are designed to turn on at the next zero crossover after application of the control voltage. This limits electromagnetic interference, reducing the chance of damage to downstream equipment. A built-in MOV reduces the likelihood of damage to the relay from rapid changes in voltage (dv/dt) and transient voltages.

Many safety and convenience features

All Gefran solid state relays come standard with an LED to indicate when the relay is in an operational state. This increases safety and speeds troubleshooting.

In addition, all GQ hockey puck type relays come standard with a load side cover that provides touch protection. The GTS DIN-Rail mounted relays also offer touch protection through the use of a removable protective cover plate.

Common Applications

- Heating controls*
- Injection molding machines*
- Semiconductor manufacturing equipment*
- Glass processing*
- Welding controls*
- Food processing*
- Industrial & commercial ovens*
- Soldering machines*
- Medical equipment*
- Office machinery*
- Robotics*

Broad selection for many applications

The Gefran GQ solid state relays are available in single phase "hockey puck" models up to 90 amps and the GTS DIN-rail single phase units with integral heatsink up to 120 amps. The GTZ three phase models with integral heatsink up to 55 amps are also available.

Opto-isolated input limits current leakage

All Gefran solid state relays feature opto-isolated inputs where an internal LED signals a photosensitive element when output switching is to occur. This provides up to 4,000V isolation between the input voltage and the output voltage and also limits current



Integral heatsink with DIN-rail mounting

A complete selection of solid state relays are available with a built-in heatsink (GTS/GTZ models). This eliminates the hassle of selecting and installing a properly sized heatsink, or mounting to a panel mount relay directly on the back pan with silicone thermoconductive grease.

Approvals

The Series GQ and GTZ solid state relays are cURus approved and CE marked. The GTZ DIN-rail solid state relays are cULus Listed and CE marked.



- ❶ Finger Safe Protection Covers
- ❷ AC or DC Input Connections
- ❸ AC Output Connection Models
- ❹ LED Status Indicator
- ❺ Internal MOV protection
- ❻ Integrated or optional heatsinks
- ❼ cURus, CE
- ❽ cULus, CE

Catalog Number Quick Guide

GQ- 15 - 24 - D - 1 - 4

	Nominal Current		Nominal Voltage		Control Voltage		Overshooting		Connectors	
Hockey Puck	15	15A AC	24	230V AC	D	3...32V DC	1	Internal protection	4	Two-pin screw connector, low profile enclosed
1-Phase	25	25A AC	60	600V AC	A	20...260V AC				
Panel Mount	50	50A AC								
	90	90A AC								

GTS- 25 / 60 - D - 0 -

	Rated Current		Rated Voltage		Control Voltage		Alarm Output		Fan	
1-Phase	15	15A AC	48	480V AC	D	6...32V DC	0	None	VEN-90	230V 14W
DIN Rail mount	25	25A AC	60	600V AC	A	20...260V AC/DC				80x80x40
	40	40A AC							VEN-91	115V 14W
	50	50A AC								80x80x40
	60	60A AC								
	75	75A AC								
	90	90A AC								
	120	120A AC								Required on 120A models only

GTZ 40 / 60 - D - 0 - VEN-91

	Nominal Current		Nominal Voltage		Control Voltage		Alarm Output		Fan	
3-Phase	25	25A AC	48	480V AC	D	5...32V DC	0	None	VEN-90	230V 14W
DIN Rail mount	40	40A AC	60	600V AC	A	20...260V AC/DC				80x80x40
	55	55A AC							VEN-91	115V 14W
										80x80x40
										Required on 40A & 55A models only

Gefran Solid State Relays

1 Pole Panel Mount Relay, 3-32V DC Control, 230V AC Output



Specifications	15 Amp		25 Amp		50 Amp		90 Amp	
	Catalog Number	Price	Catalog Number	Price	Catalog Number	Price	Catalog Number	Price
		GQ-15-24-D-1-4	45	GQ-25-24-D-1-4	50	GQ-50-24-D-1-4	79	GQ-90-24-D-1-4
Input								
Voltage Range	3 - 32V DC		3 - 32V DC		3 - 32V DC		3 - 32V DC	
Turn-on Voltage (min.)	≥ 2.7V DC		≥ 2.7V DC		≥ 2.7V DC		≥ 2.7V DC	
Turn-off Voltage (max.)	≤ 1V DC		≤ 1V DC		≤ 1V DC		≤ 1V DC	
Consumption	≤ 13mA @ 32V		≤ 13mA @ 32V		≤ 13mA @ 32V		≤ 13mA @ 32V	
Reverse Voltage	< 36V DC		< 36V DC		< 36V DC		< 36V DC	
Output								
Amp Rating AC51	15		25		50		90	
Nominal Voltage	24...230V AC		24...230V AC		24...230V AC		24...230V AC	
Maximum Voltage	20...253V AC		20...253V AC		20...253V AC		20...253V AC	
Zero Switching Voltage	≤ 20V		≤ 20V		≤ 20V		≤ 20V	
Frequency Range	45...65 Hz		45...65 Hz		45...65 Hz		45...65 Hz	
Dimension (mm)	58 (H) x 45 (W) x 30.5 (D), from base to top of control terminal 45 (D)							

1 Pole Panel Mount Relay, 20-260V AC Control, 230V AC Output



Specifications	15 Amp		25 Amp		50 Amp		90 Amp	
	Catalog Number	Price	Catalog Number	Price	Catalog Number	Price	Catalog Number	Price
		GQ-15-24-A-1-4	53	GQ-25-24-A-1-4	55	GQ-50-24-A-1-4	88	GQ-90-24-A-1-4
Input								
Voltage Range	20...260V AC		20...260V AC		20...260V AC		20...260V AC	
Turn-on Voltage (min.)	≥ 15V AC		≥ 15V AC		≥ 15V AC		≥ 15V AC	
Turn-off Voltage (max.)	≤ 6V AC		≤ 6V AC		≤ 6V AC		≤ 6V AC	
Consumption	≤ 8mA @ 260V AC		≤ 8mA @ 260V AC		≤ 8mA @ 260V AC		≤ 8mA @ 260V AC	
Output								
Amp Rating AC51	15		25		50		90	
Nominal Voltage	24...230V AC		24...230V AC		24...230V AC		24...230V AC	
Maximum Voltage	20...253V AC		20...253V AC		20...253V AC		20...253V AC	
Zero Switching Voltage	≤ 20V		≤ 20V		≤ 20V		≤ 20V	
Frequency Range	45...65 Hz		45...65 Hz		45...65 Hz		45...65 Hz	
Dimension (mm)	58 (H) x 45 (W) x 30.5 (D), from base to top of control terminal 45 (D)							

1 Pole Panel Mount Relay, 3-32V DC Control, 600V AC Output



Specifications	50 Amp		90 Amp	
	Catalog Number	Price	Catalog Number	Price
	GQ-50-60-D-1-4	96	GQ-90-60-D-1-4	134
Input				
Voltage Range	3 - 32V DC		3 - 32V DC	
Turn-on Voltage (min.)	≥ 2.7V DC		≥ 2.7V DC	
Turn-off Voltage (max.)	≤ 1V DC		≤ 1V DC	
Consumption	≤ 13mA @ 32V		≤ 13mA @ 32V	
Reverse Voltage	< 36V DC		< 36V DC	
Output				
Amp Rating AC51	50		90	
Nominal Voltage	48...600V AC		48...600V AC	
Maximum Voltage	40...660V AC		40...660V AC	
Zero Switching Voltage	≤ 40V		≤ 40V	
Frequency Range	45...65 Hz		45...65 Hz	
Dimension (mm)	58 (H) x 45 (W) x 30.5 (D), from base to top of control terminal 45 (D)			

1 Pole Panel Mount Relay, 20-260V AC Control, 600V AC Output



Specifications	50 Amp		90 Amp	
	Catalog Number	Price	Catalog Number	Price
	GQ-50-60-A-1-4	104	GQ-90-60-A-1-4	145
Input				
Voltage Range	20...260V AC		20...260V AC	
Turn-on Voltage (min.)	≥ 15V AC		≥ 15V AC	
Turn-off Voltage (max.)	≤ 6V AC		≤ 6V AC	
Consumption	≤ 8mA @ 260V AC		≤ 8mA @ 260V AC	
Output				
Amp Rating AC51	50		90	
Nominal Voltage	48...600V AC		48...600V AC	
Maximum Voltage	40...660V AC		40...660V AC	
Zero Switching Voltage	≤ 40V		≤ 40V	
Frequency Range	45...65 Hz		45...65 Hz	
Dimension (mm)	58 (H) x 45 (W) x 30.5 (D), from base to top of control terminal 45 (D)			

1 Pole DIN-Rail Mount Relay, 6-32V DC Control, 480V AC Output

**DISCONTINUED
SEE 600V**



Specifications	15 Amp		25 Amp		40 Amp		50 Amp	
	Catalog Number	Price	Catalog Number	Price	Catalog Number	Price	Catalog Number	Price
		GTS-15/480-0	99	GTS-25/480-0	111	GTS-40/480-0	134	GTS-50/480-0
Input	6 - 32V DC		6 - 32V DC		6 - 32V DC		6 - 32V DC	
Voltage Range	6 - 32V DC		6 - 32V DC		6 - 32V DC		6 - 32V DC	
Turn-on Voltage (min.)	> 5.1V DC		> 5.1V DC		> 5.1V DC		> 5.1V DC	
Turn-off Voltage (max.)	< 3V DC		< 3V DC		< 3V DC		< 3V DC	
Consumption	≤ 10mA @ 32V		≤ 10mA @ 32V		≤ 10mA @ 32V		≤ 10mA @ 32V	
Reverse Voltage	< 36V DC		< 36V DC		< 36V DC		< 36V DC	
Output	15		25		40		50	
Amp Rating AC51	15		25		40		50	
Nominal Voltage	24...480V AC		24...480V AC		24...480V AC		24...480V AC	
Maximum Voltage	20...530V AC		20...530V AC		20...530V AC		20...530V AC	
Zero Switching Voltage	< 20V		< 20V		< 20V		< 20V	
Frequency Range	45...65 Hz		45...65 Hz		45...65 Hz		45...65 Hz	
Dimension (mm)	100 (H) x 24 (W) x 107 (D)		108 (H) x 35 (W) x 142 (D)		108 (H) x 60 (W) x 142 (D)		108 (H) x 60 (W) x 142 (D)	

1 Pole DIN-Rail Mount Relay, 20-260V AC Control, 480V AC Output

**DISCONTINUED
SEE 600V**



Specifications	15 Amp		25 Amp		40 Amp		50 Amp	
	Catalog Number	Price	Catalog Number	Price	Catalog Number	Price	Catalog Number	Price
		GTS-15/480-0-AC	108	GTS-25/480-0-AC	117	GTS-40/480-0-AC	147	GTS-50/480-0-AC
Input	20...260V AC		20...260V AC		20...260V AC		20...260V AC	
Voltage Range	20...260V AC		20...260V AC		20...260V AC		20...260V AC	
Turn-on Voltage (min.)	≥ 15V AC		≥ 15V AC		≥ 15V AC		≥ 15V AC	
Turn-off Voltage (max.)	≤ 6V AC		≤ 6V AC		≤ 6V AC		≤ 6V AC	
Consumption	≤ 8mA @ 260V AC		≤ 8mA @ 260V AC		≤ 8mA @ 260V AC		≤ 8mA @ 260V AC	
Output	15		25		40		50	
Amp Rating AC51	15		25		40		50	
Nominal Voltage	24...480V AC		24...480V AC		24...480V AC		24...480V AC	
Maximum Voltage	24...530V AC		24...530V AC		24...530V AC		24...530V AC	
Zero Switching Voltage	< 20V		< 20V		< 20V		< 20V	
Frequency Range	45...65 Hz		45...65 Hz		45...65 Hz		45...65 Hz	
Dimension (mm)	100 (H) x 24 (W) x 107 (D)		108 (H) x 35 (W) x 142 (D)		108 (H) x 60 (W) x 142 (D)		108 (H) x 60 (W) x 142 (D)	

R/F = Refer to factory for availability

1 Pole DIN-Rail Mount Relay, 6-32V DC Control, 480V AC Output

DISCONTINUED
SEE 600V

Specifications	60 Amp		75 Amp		90 Amp		120 Amp	
	Catalog Number	Price	Catalog Number	Price	Catalog Number	Price	Catalog Number	Price
without integrate fan (not required)	GTS-60/480-0	301	GTS-75/480-0	358	GTS-90/480-0	633		
with integrated fan 230V							GTS-120/480-0-VEN-90	750
with integrated fan 115V							GTS-120/480-0-VEN-91	
Input	Voltage Range 6 - 32V DC		6 - 32V DC		6 - 32V DC		6 - 32V DC	
	Turn-on Voltage (min.) > 5.1V DC		> 5.1V DC		> 5.1V DC		> 5.1V DC	
	Turn-off Voltage (max.) < 3V DC		< 3V DC		< 3V DC		< 3V DC	
	Consumption ≤ 10mA @ 32V		≤ 10mA @ 32V		≤ 10mA @ 32V		≤ 10mA @ 32V	
	Reverse Voltage < 36V DC		< 36V DC		< 36V DC		< 36V DC	
Output	Amp Rating @ 40°C 60		75		90		120	
	Nominal Voltage 24...480V AC		24...480V AC		24...480V AC		24...480V AC	
	Maximum Voltage 24...530V AC		24...530V AC		24...530V AC		24...530V AC	
	Zero Switching Voltage < 20V		< 20V		< 20V		< 20V	
	Frequency Range 45...65 Hz		45...65 Hz		45...65 Hz		45...65 Hz	
Dimension (mm)	108 (H) x 80 (W) x 107 (D)		108 (H) x 127 (W) x 142 (D)		108 (H) x 127 (W) x 142 (D)		108 (H) x 127 (W) x 158 (D)	

1 Pole DIN-Rail Mount Relay, 20-260V AC Control, 480V AC Output

DISCONTINUED
SEE 600V

Specifications	60 Amp		75 Amp		90 Amp		120 Amp	
	Catalog Number	Price	Catalog Number	Price	Catalog Number	Price	Catalog Number	Price
without integrate fan (not required)	GTS-60/480-0-AC	316	GTS-75/480-0-AC	366	GTS-90/480-0-AC	646		
with integrated fan 230V							GTS-120/480-0-AC-VEN-90	770
with integrated fan 115V							GTS-120/480-0-AC-VEN-91	
Input	Voltage Range 20...260V AC		20...260V AC		20...260V AC		20...260V AC	
	Turn-on Voltage (min.) ≥ 15V AC		≥ 15V AC		≥ 15V AC		≥ 15V AC	
	Turn-off Voltage (max.) ≤ 6V AC		≤ 6V AC		≤ 6V AC		≤ 6V AC	
	Consumption ≤ 8mA @ 260V AC		≤ 8mA @ 260V AC		≤ 8mA @ 260V AC		≤ 8mA @ 260V AC	
Output	Amp Rating @ 40°C 60		75		90		120	
	Nominal Voltage 24...480V AC		24...480V AC		24...480V AC		24...480V AC	
	Maximum Voltage 24...530V AC		24...530V AC		24...530V AC		24...530V AC	
	Zero Switching Voltage < 20V		< 20V		< 20V		< 20V	
	Frequency Range 45...65 Hz		45...65 Hz		45...65 Hz		45...65 Hz	
Dimension (mm)	108 (H) x 80 (W) x 107 (D)		108 (H) x 127 (W) x 142 (D)		108 (H) x 127 (W) x 142 (D)		108 (H) x 127 (W) x 158 (D)	

R/F = Refer to factory for availability

GTS Relays are cUL (E243386)

1 Pole DIN-Rail Mount Relay, 6-32V DC Control, 600V AC Output

NEW





Specifications	15 Amp		25 Amp		40 Amp		50 Amp	
	Catalog Number	Price	Catalog Number	Price	Catalog Number	Price	Catalog Number	Price
		GTS-15/60-D-0	109	GTS-25/60-D-0	122	GTS-40/60-D-0	147	GTS-50/60-D-0
Input	6 - 32V DC		6 - 32V DC		6 - 32V DC		6 - 32V DC	
Voltage Range	6 - 32V DC		6 - 32V DC		6 - 32V DC		6 - 32V DC	
Turn-on Voltage (min.)	> 5.1V DC		> 5.1V DC		> 5.1V DC		> 5.1V DC	
Turn-off Voltage (max.)	< 3V DC		< 3V DC		< 3V DC		< 3V DC	
Consumption	≤ 10mA @ 32V		≤ 10mA @ 32V		≤ 10mA @ 32V		≤ 10mA @ 32V	
Reverse Voltage	< 36V DC		< 36V DC		< 36V DC		< 36V DC	
Output	15		25		40		50	
Amp Rating AC51	15		25		40		50	
Nominal Voltage	24...600V AC		24...600V AC		24...600V AC		24...600V AC	
Maximum Voltage	20...660V AC		20...660V AC		20...660V AC		20...660V AC	
Zero Switching Voltage	< 20V		< 20V		< 20V		< 20V	
Frequency Range	50/60 Hz		50/60 Hz		50/60 Hz		50/60 Hz	
Dimension (mm)	100 (H) x 24 (W) x 107 (D)		108 (H) x 35 (W) x 142 (D)		108 (H) x 60 (W) x 142 (D)		108 (H) x 60 (W) x 142 (D)	

1 Pole DIN-Rail Mount Relay, 20-260V AC Control, 600V AC Output





NEW

Specifications	15 Amp		25 Amp		40 Amp		50 Amp	
	Catalog Number	Price	Catalog Number	Price	Catalog Number	Price	Catalog Number	Price
		GTS-15/60-A-0	119	GTS-25/60-A-0	129	GTS-40/60-A-0	162	GTS-50/60-A-0
Input	20...260V AC/DC		20...260V AC/DC		20...260V AC/DC		20...260V AC/DC	
Voltage Range	20...260V AC/DC		20...260V AC/DC		20...260V AC/DC		20...260V AC/DC	
Turn-on Voltage (min.)	≥ 15V AC/DC		≥ 15V AC/DC		≥ 15V AC/DC		≥ 15V AC/DC	
Turn-off Voltage (max.)	≤ 6V AC/DC		≤ 6V AC/DC		≤ 6V AC/DC		≤ 6V AC/DC	
Consumption	≤ 8mA @ 260V AC/DC		≤ 8mA @ 260V AC/DC		≤ 8mA @ 260V AC/DC		≤ 8mA @ 260V AC/DC	
Output	15		25		40		50	
Amp Rating AC51	15		25		40		50	
Nominal Voltage	24...600V AC		24...600V AC		24...600V AC		24...600V AC	
Maximum Voltage	20...660V AC		20...660V AC		20...660V AC		20...660V AC	
Zero Switching Voltage	< 20V		< 20V		< 20V		< 20V	
Frequency Range	50/60 Hz		50/60 Hz		50/60 Hz		50/60 Hz	
Dimension (mm)	100 (H) x 24 (W) x 107 (D)		108 (H) x 35 (W) x 142 (D)		108 (H) x 60 (W) x 142 (D)		108 (H) x 60 (W) x 142 (D)	

1 Pole DIN-Rail Mount Relay, 6-32V DC Control, 600V AC Output

									
	Specifications		60 Amp		75 Amp		90 Amp		120 Amp
	Catalog Number	Price	Catalog Number	Price	Catalog Number	Price	Catalog Number	Price	
without integrate fan (not required)	GTS-60/60-D-0	331	GTS-75/60-D-0	394	GTS-90/60-D-0	696			
with integrated fan 230V							GTS-120/60-D-0-VEN-90		
with integrated fan 115V							GTS-120/60-D-0-VEN-91	825	
Input	Voltage Range	6 - 32V DC	6 - 32V DC	6 - 32V DC	6 - 32V DC	6 - 32V DC	6 - 32V DC		
	Turn-on Voltage (min.)	> 5.1V DC	> 5.1V DC	> 5.1V DC	> 5.1V DC	> 5.1V DC	> 5.1V DC		
	Turn-off Voltage (max.)	< 3V DC	< 3V DC	< 3V DC	< 3V DC	< 3V DC	< 3V DC		
	Consumption	≤ 10mA @ 32V	≤ 10mA @ 32V	≤ 10mA @ 32V	≤ 10mA @ 32V	≤ 10mA @ 32V	≤ 10mA @ 32V		
	Reverse Voltage	< 36V DC	< 36V DC	< 36V DC	< 36V DC	< 36V DC	< 36V DC		
Output	Amp Rating @ 40°C	60	75	90	120	120	120		
	Nominal Voltage	24...600V AC	24...600V AC	24...600V AC	24...600V AC	24...600V AC	24...600V AC		
	Maximum Voltage	20...660V AC	20...660V AC	20...660V AC	20...660V AC	20...660V AC	20...660V AC		
	Zero Switching Voltage	< 20V	< 20V	< 20V	< 20V	< 20V	< 20V		
	Frequency Range	50/60 Hz	50/60 Hz	50/60 Hz	50/60 Hz	50/60 Hz	50/60 Hz		
	Dimension (mm)	108 (H) x 80 (W) x 107 (D)		108 (H) x 127 (W) x 142 (D)		108 (H) x 127 (W) x 142 (D)		108 (H) x 127 (W) x 158 (D)	

1 Pole DIN-Rail Mount Relay, 20-260V AC Control, 600V AC Output

									
	Specifications		60 Amp		75 Amp		90 Amp		120 Amp
	Catalog Number	Price	Catalog Number	Price	Catalog Number	Price	Catalog Number	Price	
without integrate fan (not required)	GTS-60/60-A-0	348	GTS-75/60-A-0	403	GTS-90/60-A-0	711			
with integrated fan 230V							GTS-120/60-A-0-VEN-90		
with integrated fan 115V							GTS-120/60-A-0-VEN-91	847	
Input	Voltage Range	20...260V AC/DC	20...260V AC/DC	20...260V AC/DC	20...260V AC/DC	20...260V AC/DC	20...260V AC/DC		
	Turn-on Voltage (min.)	≥ 15V AC/DC	≥ 15V AC/DC	≥ 15V AC/DC	≥ 15V AC/DC	≥ 15V AC/DC	≥ 15V AC/DC		
	Turn-off Voltage (max.)	≤ 6V AC/DC	≤ 6V AC/DC	≤ 6V AC/DC	≤ 6V AC/DC	≤ 6V AC/DC	≤ 6V AC/DC		
	Consumption	≤ 8mA @ 260V AC/DC	≤ 8mA @ 260V AC/DC	≤ 8mA @ 260V AC/DC	≤ 8mA @ 260V AC/DC	≤ 8mA @ 260V AC/DC	≤ 8mA @ 260V AC/DC		
Output	Amp Rating @ 40°C	60	75	90	120	120	120		
	Nominal Voltage	24...600V AC	24...600V AC	24...600V AC	24...600V AC	24...600V AC	24...600V AC		
	Maximum Voltage	20...660V AC	20...660V AC	20...660V AC	20...660V AC	20...660V AC	20...660V AC		
	Zero Switching Voltage	< 20V	< 20V	< 20V	< 20V	< 20V	< 20V		
	Frequency Range	50/60 Hz	50/60 Hz	50/60 Hz	50/60 Hz	50/60 Hz	50/60 Hz		
	Dimension (mm)	108 (H) x 80 (W) x 107 (D)		108 (H) x 127 (W) x 142 (D)		108 (H) x 127 (W) x 142 (D)		108 (H) x 127 (W) x 158 (D)	

Gefran Solid State Relays

GTS Relays are cUL (E243386)

3 Pole DIN-Rail Mount Relay, 5-32V DC Control, 480V AC Output

**DISCONTINUED
SEE 600V**



Specifications		25 Amp		40 Amp		55 Amp	
		Catalog Number	Price	Catalog Number	Price	Catalog Number	Price
	Without integrated fan (not required)	GTZ25/480-0-0	285				
	with integrated fan 230V AC			GTZ40/480-0-0-VEN-90	330	GTZ55/480-0-0-VEN-90	390
	with integrated fan 115V AC			GTZ40/480-0-0-VEN-91		GTZ55/480-0-0-VEN-91	
Input	Voltage Range	5 - 32V DC		5 - 32V DC		5 - 32V DC	
	Turn-on Voltage (min.)	> 4.5V DC		> 4.5V DC		> 4.5V DC	
	Turn-off Voltage (max.)	≤ 3V DC		≤ 3V DC		≤ 3V DC	
	Consumption	18 mA @ 5V DC - 22mA @ 32V DC		18 mA @ 5V DC - 22mA @ 32V DC		18 mA @ 5V DC - 22mA @ 32V DC	
	Reverse Voltage	< 36V DC		< 36V DC		< 36V DC	
Output	Amp Rating AC51	25		40		55	
	Nominal Voltage	24...480V AC		24...480V AC		24...480V AC	
	Maximum Voltage	24...530V AC		24...530V AC		24...530V AC	
	Zero Switching Voltage	< 20V		< 20V		< 20V	
	Frequency Range	45...65 Hz		45...65 Hz		45...65 Hz	
Dimension (mm)		100 (H) x 24 (W) x 107 (D)		108 (H) x 35 (W) x 142 (D)		108 (H) x 60 (W) x 142 (D)	

3 Pole DIN-Rail Mount Relay, 5-32V DC Control, 600V AC Output

**DISCONTINUED
SEE 600V**



Specifications		40 Amp		55 Amp	
		Catalog Number	Price	Catalog Number	Price
	with integrated fan 230V AC	GTZ40/600-0-0-VEN-90	350	GTZ55/600-0-0-VEN-90	410
	with integrated fan 115V AC	GTZ40/600-0-0-VEN-91		GTZ55/600-0-0-VEN-91	
Input	Voltage Range	5 - 32V DC		5 - 32V DC	
	Turn-on Voltage (min.)	> 4.5V DC		> 4.5V DC	
	Turn-off Voltage (max.)	≤ 3V DC		≤ 3V DC	
	Consumption	18 mA @ 5V DC - 22mA @ 32V DC		18 mA @ 5V DC - 22mA @ 32V DC	
	Reverse Voltage	< 36V DC		< 36V DC	
Output	Amp Rating AC51	40		55	
	Nominal Voltage	24...600V AC		24...600V AC	
	Maximum Voltage	24...660V AC		24...660V AC	
	Zero Switching Voltage	< 20V		< 20V	
	Frequency Range	45...65 Hz		45...65 Hz	
Dimension (mm)		108 (H) x 35 (W) x 142 (D)		108 (H) x 60 (W) x 142 (D)	

GTZ Relays are cUR (E243386). Not CSA.

3 Pole DIN-Rail Mount Relay, 5-32V DC Control, 600V AC Output

NEW



Specifications		25 Amp		40 Amp		55 Amp	
		Catalog Number	Price	Catalog Number	Price	Catalog Number	Price
	Without integrated fan (not required)	GTZ25/60-D-0	305				
	with integrated fan 230V AC			GTZ40/60-D-0-VEN-90	350	GTZ55/60-D-0-VEN-90	410
	with integrated fan 115V AC			GTZ40/60-D-0-VEN-91		GTZ55/60-D-0-VEN-91	
Input	Voltage Range	5 - 32V DC		5 - 32V DC		5 - 32V DC	
	Turn-on Voltage (min.)	> 4.5V DC		> 4.5V DC		> 4.5V DC	
	Turn-off Voltage (max.)	≤ 3V DC		≤ 3V DC		≤ 3V DC	
	Consumption	18 mA @ 5V DC - 22mA @ 32V DC		18 mA @ 5V DC - 22mA @ 32V DC		18 mA @ 5V DC - 22mA @ 32V DC	
	Reverse Voltage	< 36V DC		< 36V DC		< 36V DC	
Output	Amp Rating AC51	40		40		55	
	Nominal Voltage	24...600V AC		24...600V AC		24...600V AC	
	Maximum Voltage	24...660V AC		24...660V AC		24...660V AC	
	Zero Switching Voltage	< 20V		< 20V		< 20V	
	Frequency Range	50/60 Hz		50/60 Hz		50/60 Hz	
Dimension (mm)		100 (H) x 24 (W) x 107 (D)		108 (H) x 35 (W) x 142 (D)		108 (H) x 60 (W) x 142 (D)	

3 Pole DIN-Rail Mount Relay, 20...260V AC Control, 600V AC Output





NEW

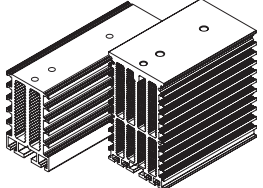
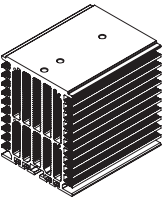
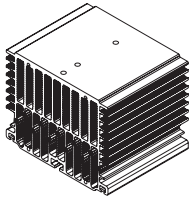

Specifications		25 Amp		40 Amp		55 Amp	
		Catalog Number	Price	Catalog Number	Price	Catalog Number	Price
	Without integrated fan (not required)	GTZ25/60-A-0	342				
	with integrated fan 230V AC			GTZ40/60-A-0-VEN-90	392	GTZ55/60-A-0-VEN-90	459
	with integrated fan 115V AC			GTZ40/60-A-0-VEN-91		GTZ55/60-A-0-VEN-91	
Input	Voltage Range	20...260V AC/DC		20...260V AC/DC		20...260V AC/DC	
	Turn-on Voltage (min.)	≥ 15V AC/DC		≥ 15V AC/DC		≥ 15V AC/DC	
	Turn-off Voltage (max.)	≤ 6V AC/DC		≤ 6V AC/DC		≤ 6V AC/DC	
	Consumption	≤ 8mA @ 260V AC/DC		≤ 8mA @ 260V AC/DC		≤ 8mA @ 260V AC/DC	
Output	Amp Rating @ 40°C	60		60		55	
	Nominal Voltage	24...600V AC		24...600V AC		24...600V AC	
	Maximum Voltage	24...660V AC		24...660V AC		24...660V AC	
	Zero Switching Voltage	< 20V		< 20V		< 20V	
	Frequency Range	50/60 Hz		50/60 Hz		50/60 Hz	
Dimension (mm)		100 (H) x 24 (W) x 107 (D)		108 (H) x 35 (W) x 142 (D)		108 (H) x 60 (W) x 142 (D)	

GTZ Relays are cUR (E243386). Not CSA.

Accessories

Heatsinks	Description	Catalog Number	Price
 <p>DIS-25GD DIS-50G</p>	Heatsink – Extruded aluminum DIN-rail mount for mounting one GQ relay. Includes PAN-1 kit attachment for panel mounting. <ul style="list-style-type: none"> - For use with GQ 15A & 25A relays - 100 x 24 x 65mm - Thermal Resistance $R_{th} > 2.8$ K/W 	DIS-25GD	97
	<ul style="list-style-type: none"> - For use with GQ 25A & 50A relays - 100 x 60 x 100mm - Thermal Resistance $R_{th} > 8.3$ K/W 	DIS-50G	97
	Heatsink – Extruded aluminum DIN-rail mount for mounting one GQ relay. Includes PAN-1 kit attachment for panel mounting. <ul style="list-style-type: none"> - For use with GQ 50A relays - 100 x 80 x 100mm - Thermal Resistance $R_{th} > 0.66$ K/W 	DIS-60G	115
	Heatsink – Extruded aluminum DIN-rail mount for mounting one GQ relay. Includes PAN-1 kit attachment for panel mounting. <ul style="list-style-type: none"> - For use with GQ 90A relays - 100 x 126 x 100mm - Thermal Resistance $R_{th} > 0.56$ K/W 	DIS-90G	145
	Kit Attachment – Allows for panel mounting the GTS Series and DIS heat sinks. Includes 2 plastic supports, 2 screws, and 2 washers.	PAN-1	19
	Silicone thermoconductive paste – for coupling the GQ Relay power module to the heat sink. 100 g tube.	SIL-1	82
	Graphite Film – 35 x 55 mm graphite film for GQ relays. <ul style="list-style-type: none"> - 0.12 mm thick, 2.1 W (m^2K). - 200 x 240 mm sheet with 25 adhesives 	SIL-GQ	79

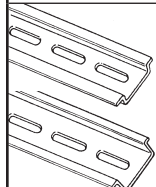
Accessory	Description	Catalog Number	Price
	DIN-rail - 2 meter lengths (6'6") Top Hat, low profile (price per rail) Top Hat, high profile (package of 20, price per rail)	3F 3AF	See page A51

Cross Reference Series SAR/SAS to Gefran Solid State Relays

Sprecher+Schuh Catalog Number	Gefran Catalog Number	Gefran Product Status
SAR Series DIN-Rail Mount		
SAR6-25-1D	GTS-25/60-D-0	
SAR6-25-1	GTS-25/60-A-0	
SAR6-40-1D	GTS-40/60-D-0	
SAR6-40-1	GTS-40/60-A-0	
SAR6-50-1D	GTS-50/60-D-0	
SAR6-50-1	GTS-50/60-A-0	
SAR6-75-1D	GTS-75/60-D-0	
SAR6-75-1	GTS-75/60-A-0	
SAR6-100-1D	GTS-90/60-D-0	Select GTS-120/60-D... For above 90A+
SAR6-100-1	GTS-90/60-A-0	Select GTS-120/60-A... For above 90A+
~	GTS-120/60-D-0-VEN*	New 120A offering
~	GTS-120/60-A-0-VEN*	New 120A offering
SAR6-30-3D	GTZ25/60-D-0	Select GTZ40/60-D-0-VEN* for above 25A+
SAR6-30-3	GTZ25/60-A-0	Select GTZ40/60-A-0-VEN* for above 25A+
~	GTZ40/60-D-0-VEN*	New 40A offering
~	GTZ40/60-A-0-VEN*	New 40A offering
~	GTZ55/60-D-0-VEN*	New 55A offering
~	GTZ55/60-A-0-VEN*	New 55A offering
SAS Series Panel Mount		
SAS3-10-1D	GQ-15-24-D-1-4	
SAS3-10-1	GQ-15-24-A-1-4	
SAS3-25-1D	GQ-25-24-D-1-4	
SAS3-25-1	GQ-25-24-A-1-4	
SAS3-50-1D	GQ-50-24-D-1-4	
SAS3-50-1	GQ-50-24-A-1-4	
SAS3-75-1D	GQ-90-24-D-1-4	
SAS3-75-1	GQ-90-24-A-1-4	
SAS6-50-1D	GQ-50-60-D-1-4	
SAS6-50-1	GQ-50-60-A-1-4	
SAS6-75-1D	GQ-90-60-D-1-4	
SAS6-75-1	GQ-90-60-A-1-4	

* Suffix code for selected fan voltage

Technical Information

			GQ-15-24-...	GQ-25-24-...	GQ-50-24-...	GQ-90-24-...	GQ-50-60-...	GQ-90-60-...
Amp Rating	AC51	[A rms]	15	25	50	90	50	90
	AC53	[A rms]	3	5	15	20	15	20
Min. load current		[A rms]	0.1	0.3	0.3	0.5	0.3	0.5
Repetitive overcurrent (t = 1s)		[A rms]	≤ 35	≤ 60	≤ 125	≤ 150	≤ 125	≤ 150
Non-repetitive overcurrent (t = 20 s)		[A p]	200	300	600	1500	600	1500
Current drop at nominal voltage and frequencies		[mA rms]	≤ 8	≤ 8	≤ 8	≤ 10	≤ 8	≤ 10
I ² t for fusing (t = 1-10 ms)		[A ² s]	≤ 200	≤ 450	≤ 1,800	≤ 11,200	≤ 1,800	≤ 11,200
Critical di/dt		[A/μs]	≥ 100	≥ 100	≥ 100	≥ 100	≥ 100	≥ 100
Voltage drop at nominal current		[V rms]	≤ 1.45	≤ 1.45	≤ 1.35	≤ 1.35	≤ 1.35	≤ 1.35
Critical dV/dt off state		[V/μs]	≥ 1000	≥ 1000	≥ 1000	≥ 1000	≥ 1000	≥ 1000
I _{th}		[A]	15	25	50	90	50	90

Input

DC Control

Voltage Range	3 - 32V DC
Turn-on Voltage (min.)	≥ 2.7V DC
Turn-off Voltage (max.)	≤ 1V DC
Consumption	≤ 13mA @ 32V
Reverse Voltage	< 36V DC

AC Control

Voltage Range	20...260V AC/V DC
Turn-on Voltage (min.)	≥ 15V AC/V DC
Turn-off Voltage (max.)	≤ 6V AC/V DC
Consumption	≤ 8mA ac/cc @ 260V AC/V DC

Output

Nominal Voltage	24...230V AC	48...600V AC
Maximum Voltage	20...253V AC	40...660V AC
Non-repetitive Voltage	600Vp	1200Vp
Zero Switching Voltage	≤ 20V	≤ 40V
Frequency Range	45...65 Hz	45...65 Hz

Insulation

Nominal voltage	input/output	[V ac]	≥ 4000
	output/case	[V ac]	≥ 2500
Resistance	input/output	[Ω]	≥ 10 ¹⁰
	output/case	[Ω]	≥ 10 ¹⁰
Capacity	input/output	[pF]	≤ 8
	output/case	[pF]	≤ 100

Ambient Conditions

Ambient temperature	-25...+80°C [-13...176°F]
Storage temperature	-55...+100°C [-67...212°F]
Maximum relative humidity	50% at 40°C
Maximum installation altitude	2000 m above sea level
Pollution level	3

Thermal Features

Junction temperature	≤ 125°C [257°F]						
R _{th}	junction/ambient	[K/W]	≤ 12	≤ 12	≤ 12	≤ 12	≤ 12
	junction/case	[K/W]	≤ 1.25	≤ 1.25	≤ 0.65	≤ 0.30	≤ 0.65

Heatsink

$$R_{th} = (90^{\circ}\text{C} - \text{max. amb. T} / P_d)$$

Where P_d = dissipated power

Max. amb. T = max. air temperature inside the electrical cabinet

Use a heatsink with thermal resistance less than the calculated R_{th} value

Terminals and Leads

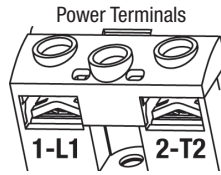

Command Terminals

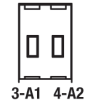

Terminal Type

Screw (m4) contact area (LxP) 13 x 11 mm

screw M2.5 MORS4 (22...16 AWG)

1(L1) 2(T1)		3(A1) 4(A2)		
	1x 2,5...6 mm ² 1x 14...10 AWG 2x 1,5...2,5 mm ² 2x 16...14 AWG 2x 2,5...6 mm ² 2x 14...10 AWG		1x 0,2...2,5 mm ² 1x 24...14 AWG 2x 0,2...1,5 mm ² 2x 24...16 AWG	
	1x 1,5...6 mm ² 1x 16...10 AWG 2x 1,5...6 mm ² 2x 16...10 AWG		1x 0,25...2,5 mm ² 1x 23...14 AWG 2x 0,25...1 mm ² 2x 23...18 AWG	
	1x 2,5...25 mm ² 1x 14...4 AWG			
	2...2,4 Nm 18...21 lbxin			
	GQ..15.. 2,5 mm ² 14 AWG	GQ..25.. 6 mm ² 10 AWG	GQ..50.. 12 mm ² (2x6) 7 AWG (2x10)	GQ..90.. 25 mm ² 4 AWG

Recommended Fuses (by others)

HIGH SPEED FUSES			
Model	Size I ^T	Bussman Part No.	Dissipated power @ I _n
GQ15...	16A 150A ² S	FWC16A10F 338470	3,5W
	25A 390A ² S	FWC25A10F 338474	6W
GQ25...	375A ² S	FWC25A14F 338130	7W
	50A 1800A ² S	FWC50A14F 338079	9W
GQ50...	50A 1600A ² S	FWC50A22F 338127	9,5W
	80A 6600A ² S	FWP80A22F 338199	14W
GQ90...	100A 12500A ² S	FWP100A22F 338478	16W

Heatsink / Thermal Resistance

Model	Gefran Heatsink (see accessories)	Thermal Resistance
GQ15... GQ25...	DIS 25GD DIS 50G	$R_{th} \geq 2,8 \text{ K/W}$ $R_{th} \geq 0,83 \text{ K/W}$
GQ50...	DIS 50G	$R_{th} \geq 0,83 \text{ K/W}$
GQ90...	DIS 90G	$R_{th} \geq 0,56 \text{ K/W}$

Data relating to 40°C ambient temperature, heatsink in vertical position with 15 cm of free air above and below.

Section Cable

Model	Section
GQ15...	2.5mm ² / 14 AWG
GQ25...	6mm ² / 10 AWG
GQ50...	12mm ² / 7 AWG
GQ90...	25mm ² / 4 AWG

Minimum allowed rated section based on the rated currents of the power solid state relays, for copper leads isolated in PVC in continuous use and at room temperature of 40°C, according to standards CEI 44-5, CEI 17-11, IEC 408 pursuant to standard EN60204-1.

Power terminals in compliance with standard EN60947-1

EMC Emission

EN 61000-6-4	Emissions conducted at radiofrequency	Class A (Industrial devices)
EN 61000-6-4	Emissions irradiated at radiofrequency	Class A (Industrial devices)

The product is designed for type A environments. Use of the product in type B environments may cause undesired electromagnetic noise. In this case, the user should take appropriate steps for improvement.

EMC Immunity

EN 61000-6-2	Immunity for industrial environments	
EN 61000-4-2	Electrostatic discharges 4kV by contact; 8 kV in air.	Performance criterion 2
EN 61000-4-6	Electromagnetic field at radiofrequency Test level 3. 0.15-80MHz	Performance criterion 1
EN 61000-4-3	Electromagnetic field at radiofrequency Test level 10V/m. 80-1000MHz	Performance criterion 1
EN 61000-4-4	Immunity to burst	Test level 2kV/100 KHz. Performance criterion 2
EN 61000-4-5	Immunity to surge	Test level: 2kV (Phase-ground); 1kV (Phase-phase). Performance criterion 2

Safety

EN 61010-1	Safety requirements
------------	---------------------

Technical Information

Amp Rating		GTS-15	GTS-25	GTS-40	GTS-50	GTS-60	GTS-75	GTS-90	GTS-120
Rated Current @ 40°C (continuous service)	[A rms]	15	25	40	50	60	75	90	120
Non-repetitive overcurrent (t = 20 ms)	[A]	400	400	600	1150	1150	1300	1500	1500
I ² t for blowout	[A ² s]	≤ 450	≤ 645	≤ 1010	≤ 6600	≤ 6600	≤ 8000	≤ 11,200	≤ 11,200
dV/dt critical with output deactivated	[V/μs]	1000	1000	1000	1000	1000	1000	1000	1000

Input

DC Control	Voltage Range	6 - 32V DC
	Turn-on Voltage (min.)	> 5.1V DC
	Turn-off Voltage (max.)	< 3V DC
	Consumption	≤ 10mA @ 32V
	Reverse Voltage	< 36V DC
AC Control	Voltage Range	20...260V AC/DC
	Turn-on Voltage (min.)	≥ 15V AC/DC
	Turn-off Voltage (max.)	≤ 6V AC/DC
	Consumption	≤ 8mA @ 260V AC/DC

Output

Nominal Voltage	24...600V AC
Maximum Voltage	20...660V AC
Non-repetitive Voltage	500Vp for 230V models, 1200Vp for 480V models
Zero Switching Voltage	< 20V
Frequency Range	50/60 Hz

Isolation

Rated voltage input/output	[V ac]	≥ 4000
----------------------------	--------	--------

Ambient Conditions

Ambient temperature	0°...+80°C [32°...+176°F] according to dissipation curves
Storage temperature	-20...+85°C [-4°...+185°F]
Maximum relative humidity	50% at 40°C
Maximum installation altitude	2000m above sea level
Pollution level	3

Dissipation Curves

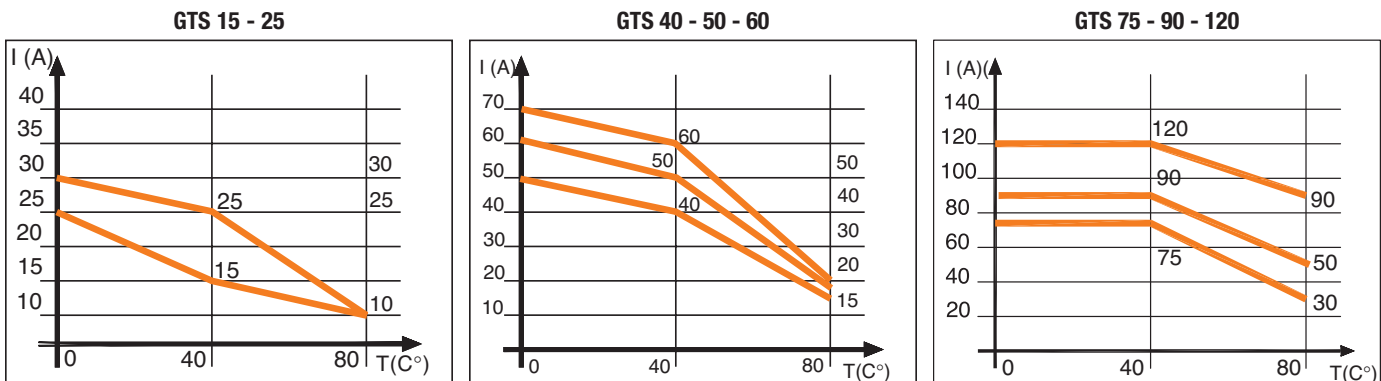

N.B.: Curves for the GTS 120 refer to the device complete with standard running.

Technical Information

Terminal and Conductors

Size	Terminal	Contact area (WxD) screw type	Type of preisolated terminal ②	Max section. ① conductor tightening torque
15/20A	C	6.4x9 M3	1, 2, 4	6mm ² / 10AWG 0.6Nm max
	P	6.4x9 M3	1, 2, 4	6mm ² / 10AWG 0.4 - 0.6Nm
	G	9x12 M5	1	6mm ² / 10AWG 1.3 - 1.8Nm
25A	C	6.4x9 M3	1, 2, 4	6mm ² / 10AWG 0.6Nm max
	P	6.4x9 M3	1, 2	6mm ² / 10AWG 0.4 - 0.6Nm
	G	9x12 M5	1	6mm ² / 10AWG 1.3 - 1.8Nm
40A	C	6.3x9 M3	1, 2, 3	2.5mm ² / 14AWG 0.6Nm max
	P	12x12 M5	1, 2	16mm ² / 6AWG 1.5 - 2.2Nm
	G	11.5x12 M5	1	16mm ² / 6AWG 1.5 - 2.2Nm
50/60A	C	6.3x9 M3	1, 2, 3	2.5mm ² / 14AWG 0.6Nm max
	P	16x18 M6	1, 2	50mm ² / 0AWG 3.5 - 6Nm
	G	14x16 M5	1	50mm ² / 0AWG 1.8 - 2.5Nm
75-90A	C	6.3x9 M3	1, 2, 3	2.5mm ² / 14AWG 0.6Nm max
	P	16x18 M6	1, 2	50mm ² / 0AWG 3.5 - 6Nm
	G	14x16 M5	1	50mm ² / 0AWG 1.8 - 2.5Nm
120A	C	6.3x9 M3	1, 2, 3	2.5mm ² / 14AWG 0.6Nm max
	P	16x18 M6	1, 2	50mm ² / 0AWG 3.5 - 6Nm
	G	14x16 M5	1	50mm ² / 0AWG 1.8 - 2.5Nm

Terminal: C = Control, P = Power, G = Ground

Terminal Types



1. Eyelet



2. Fork



3. Tip



4. Faston

- ① The max. sections specified refer to unipolar copper wires isolated in PVC..
- ② The screw terminals must be suitable for field wiring connection only when the wire is provided with eyelet tube terminal type 1.

Technical Information

Amp Rating		GTZ-25/60	GTZ-40/60	GTZ-55/60	GTZ-40/60	GTZ-55/60
Category AC51, AC53a	[A rms]	25	40	55	40	55
Nominal current (I_{max})	[A rms]	3x25	3x40	3x55	3x40	3x55
Non-repetitive overcurrent (t = 20 ms)	[A]	400	600	1150	600	1150
I^2t for blowout	[A ² s]	645	1010	6600	1010	6600
DC Control Input	Voltage Command Circuit (U_c)	5...32V DC				
	Turn-on Voltage (min.)	> 4.5V DC				
	Turn-off Voltage (max.)	< 3V DC				
	Consumption	≤ 18mA @ 5V DC - 22mA @ 32V DC				
	Reverse Voltage	< 36V DC				
AC Control INPUT	Voltage Range	20...260V AC/DC				
	Turn-on Voltage (min.)	≥ 15V AC/DC				
	Turn-off Voltage (max.)	≤ 6V AC/DC				
	Consumption	≤ 8mA @ 260V AC/DC				
	Frequency Range	50/60 Hz				
Activation Time		≤ 1/2 cycle				
Deactivation Time		≤ 1/2 cycle				
Critical dV/dt OFF-state	[V/μs]	1000				
Potential drop at rated current	[Vrms]	≤ 1.4				
Peak Voltage		>1200V DC				
Protection		IP20				
Isolation						
Nominal voltage (U)	[V ac]	600				
Insulation						
Nominal voltage input/output	[KV ac]	4				
Nominal impulse withstand (U_{imp})	[V AC]	2500				
Ambient Conditions						
Working temperature		-20...+80°C [-4°...176°F]				
Storage temperature		-20...+85°C [-4°...185°F]				
Maximum relative humidity		50% at 40°C				
Maximum installation altitude		1000m asl				
Pollution level		3 (suitable for use in degree 2 environment)				
Class		A (industrial device)				

Dissipation Curve

GTZ 25 - 40 - 55

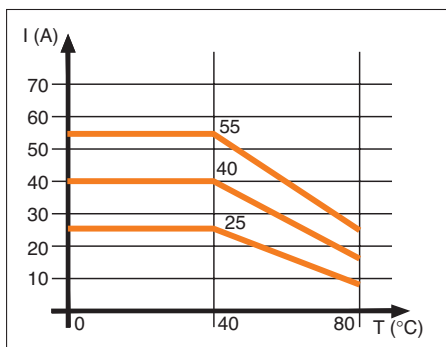

Technical Information

Terminals and Conductors

Size	Nominal Section Cable mm ²	Control Terminal (A1, A2, B1, B2)			Power Terminal (L1, L2, L3, T1, T2, T3)			Ground Terminal ❶	
		Contact area (WxD) screw type	Type of preisolated terminal	Section con- ductor tighten- ing torque ❷	Contact area (WxD) screw type	Type of preisolated terminal	Max. section conductor tightening torque	Contact area (WxD) screw type	Max. section conductor tightening torque
25A	6	6.3x9 M3	Eye / fork / tip	min. 0.35 mm ² max. 2.5 mm ² 0.6 Nm Max	12 x 12 M5	Eye / fork / tip	Tip Terminal min. 1mm ² (17AWG) max. 10mm ² (7AWG)	12x12 self-tapping screw 3.9x12 DIN7981	min. 1mm ² (17AWG) max. 16mm ² (5AWG) 1.5 ...1.8Nm
40A	10						Eye or Fork Terminal min. 1mm ² (17AWG) max. 16mm ² (5AWG)		
55A	16						1.5 ...2.2Nm	12x12 M5	min. 1mm ² (17AWG) max. 16mm ² (5AWG) 2.5Nm

❶ Note: The maximum sections specified refer to unipolar copper wires isolated in PVC. For the ground terminal, an eye wire terminal is required.
(WxD) = Width x depth

❷ The minimum acceptable nominal section based on the nominal currents of the power solid state units is given for copper conductors isolated in PVC, under continuous operating conditions and at 40°C ambient temperature according to standards CEI 44-5, CEI 17-11, IEC 408 in accordance with EN60204-1.

Connection Examples

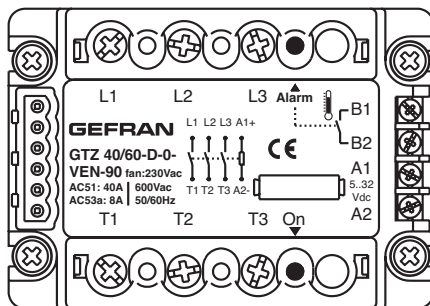

- L1 : Phase 1 input
- L2 : Phase 2 input
- L3 : Phase 3 input
- T1 : Phase 1 output
- T2 : Phase 2 output
- T3 : Phase 3 output
- A1 : Control signal (+)
- A2 : Control signal (-)
- B1 : Alarm output (+) (Special unit)
- B2 : Alarm output (-) (Special unit)
- Led1: Red led signal indicator
- Led2: Yellow led (alarm overtemperature junction)

Series GQ Solid State Relays

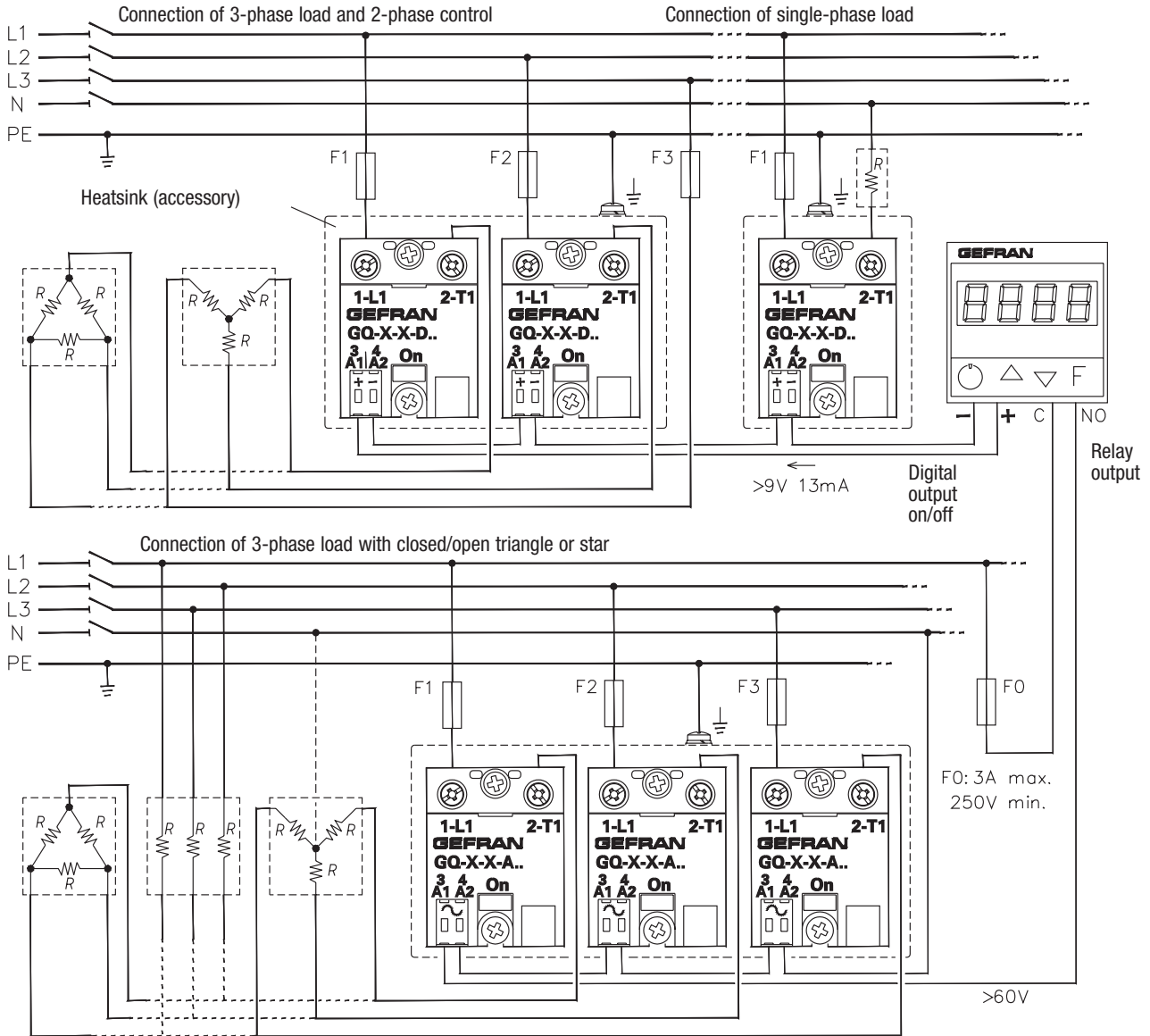

Series GQ Fuse Connections

The solid state group must be connected using proper fuses against short circuits

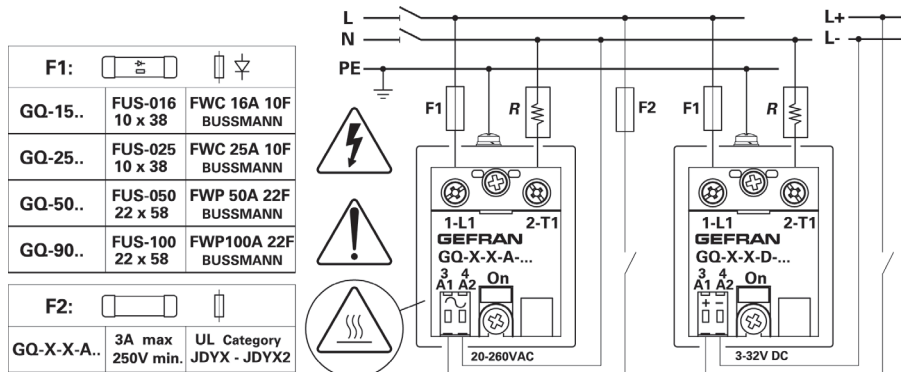

Series GTS Solid State Relays

Single-phase connection

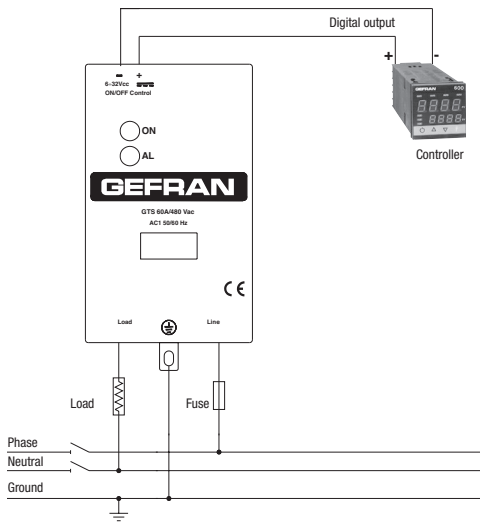

Three-phase Star connection with neutral

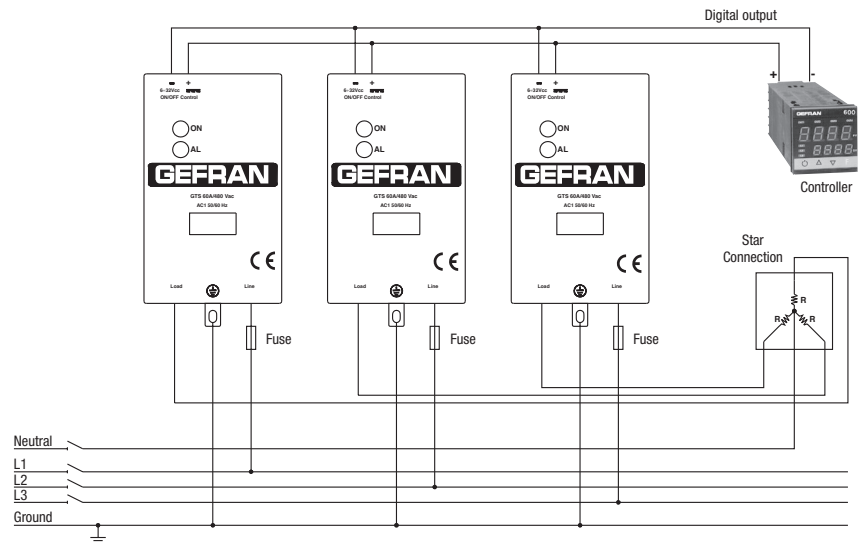

Three-phase Triangle or Star connection without neutral on two phases

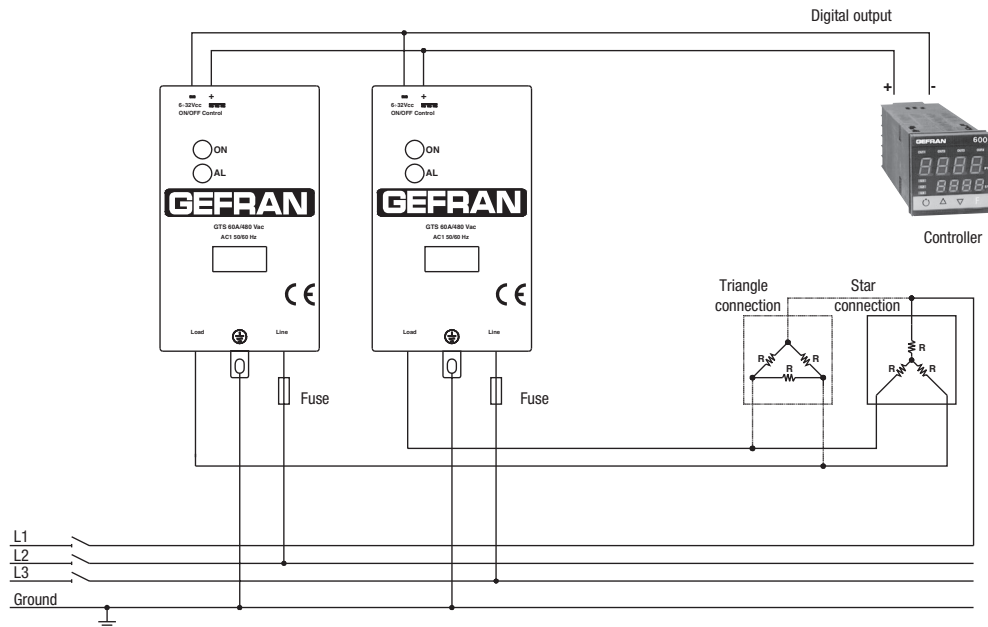

Gefran Solid State Relays

Series GTZ Solid State Relays

Three-phase Triangle or Star connection (with and without neutral)

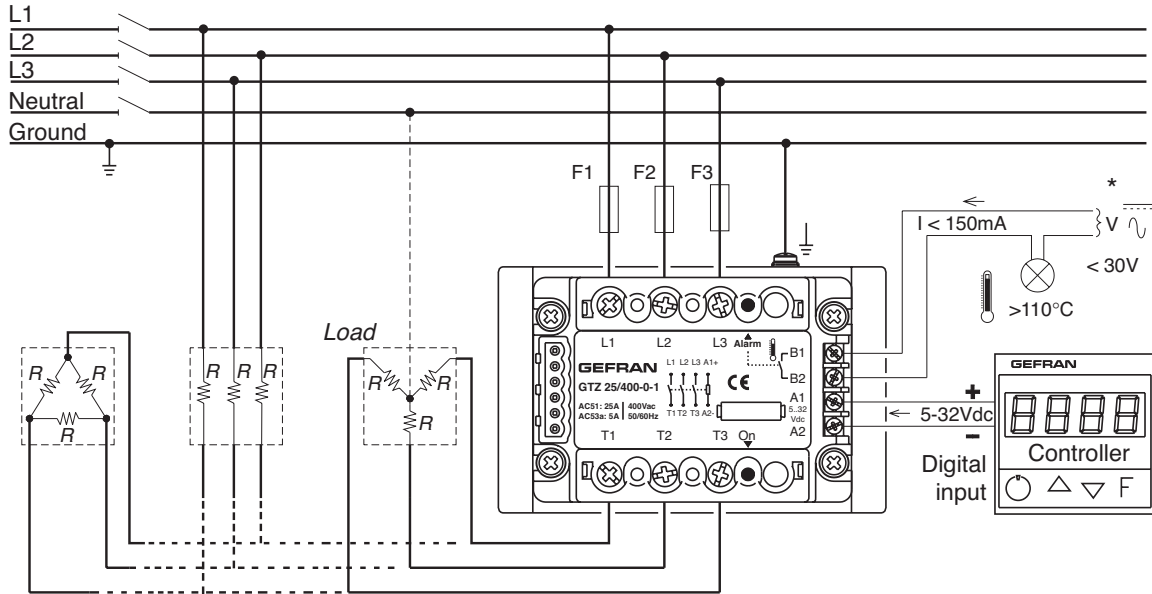

* Only in the version with option overtemperature alarm output

GQ Panel Mount Relays

Dimensions are in millimeters (inches). Dimensions not intended for manufacturing purposes.

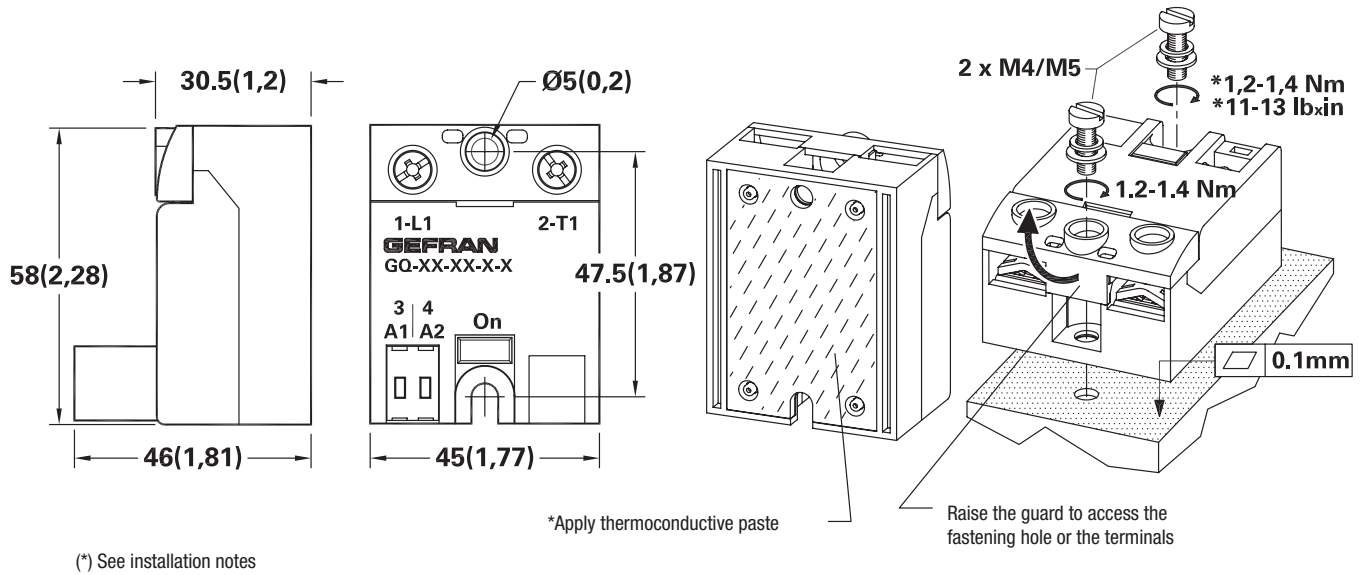

GTS 1-Pole DIN-Rail Mount Relays

Dimensions are in millimeters (inches). Dimensions not intended for manufacturing purposes.

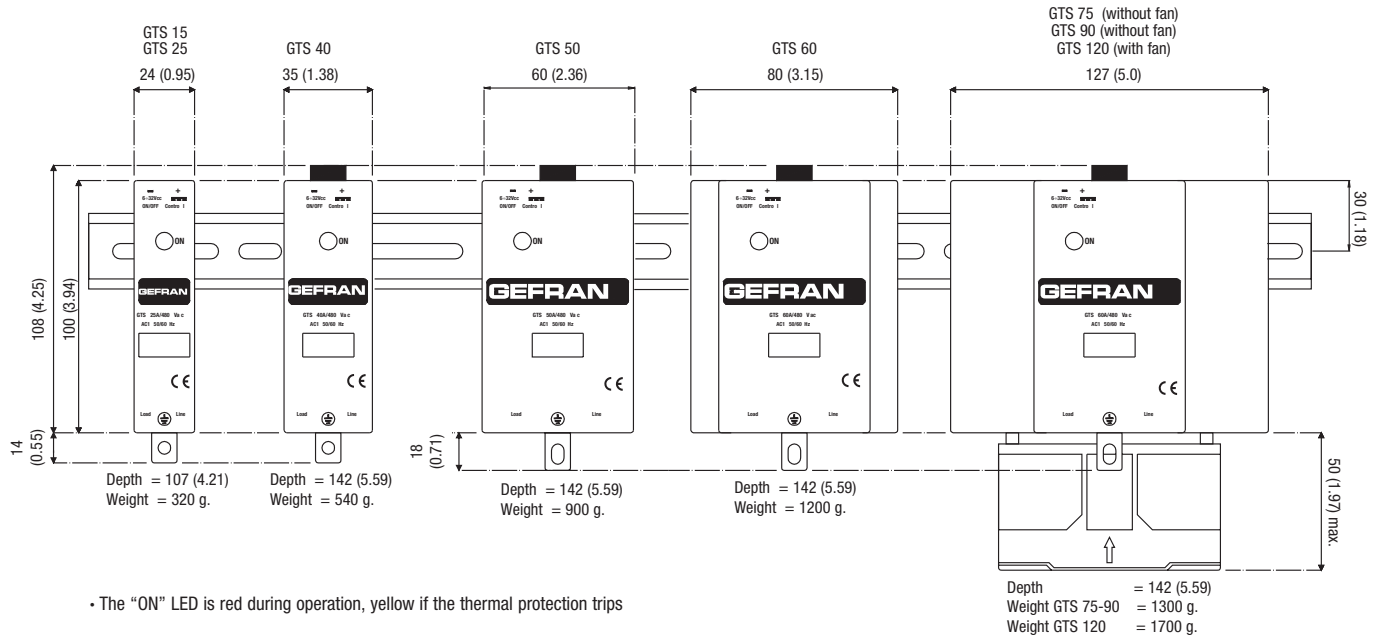

PAN-1 Panel Mount Accessory for GTS - Hole Template

GTS 1-Pole Relays	Length	Width
	mm (inches)	mm (inches)
GTS-15...25	112 (4.41)	0 (0.00)
GTS-40	112 (4.41)	25 (0.98)
GTS-50...60	112 (4.41)	44 (1.73)
GTS-90...120	112 (4.41)	113 (4.45)

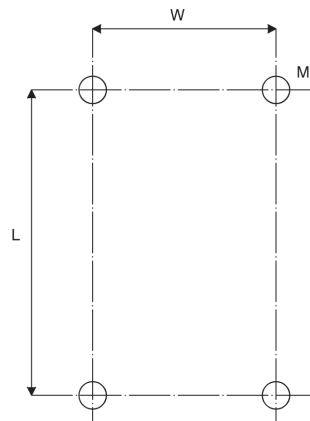

GTZ 3-Pole DIN-Rail Mount Relays

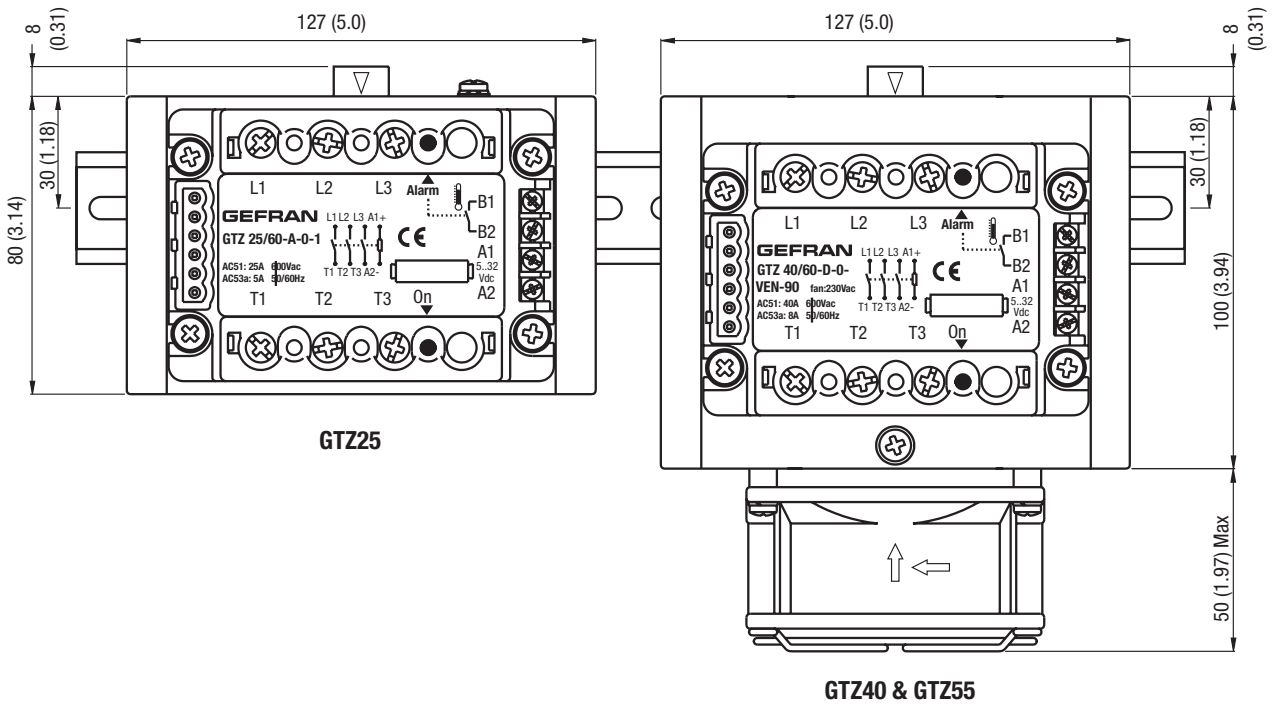

General Application Notes

Heatsinks

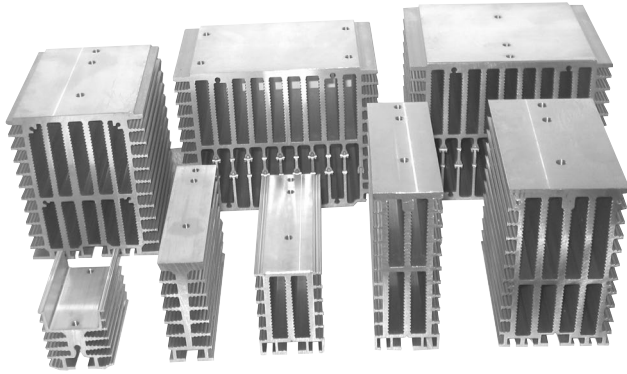

Different models of heatsinks have been designed and tested to meet size and dimension needs.

How to choose a heatsink

- Set max. air temperature inside the panelboard (T_{max_a})
- Set max. operating current: $I_{max} = I_{nom. load} + 10\%$
- Draw on the “graphs” T_{max_a} , I_{max} points.
- Choose the smallest heatsink (starting from upwards), which point [T_{max_a} , I_{max}] is in the gray working area of dissipation curves
- Respect installation distances

Installation

In order to obtain best reliability, it is important to install a heatsink correctly inside the panel, to reach an adequate thermal exchange between the device and the surrounding air in natural convection conditions.

How to install it correctly:

Mount it vertically (max. 10° inclination from the vertical axis)

- Vertical distance between a heatsink and the panel wall: 100 mm at least.
- Horizontal distance between a heatsink and the panel wall: 20 mm at least.
- Vertical distance between two heatsinks: 300 mm at least.
- Horizontal distance between two heatsinks: 40 mm at least.

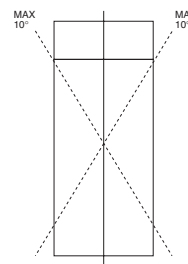

Check that cable channels do not reduce these distances; should it happen, mount the relays overhanging from the panel, so that the air can flow vertically on the heatsink without obstacles (see Fig.1).

Fig. 1

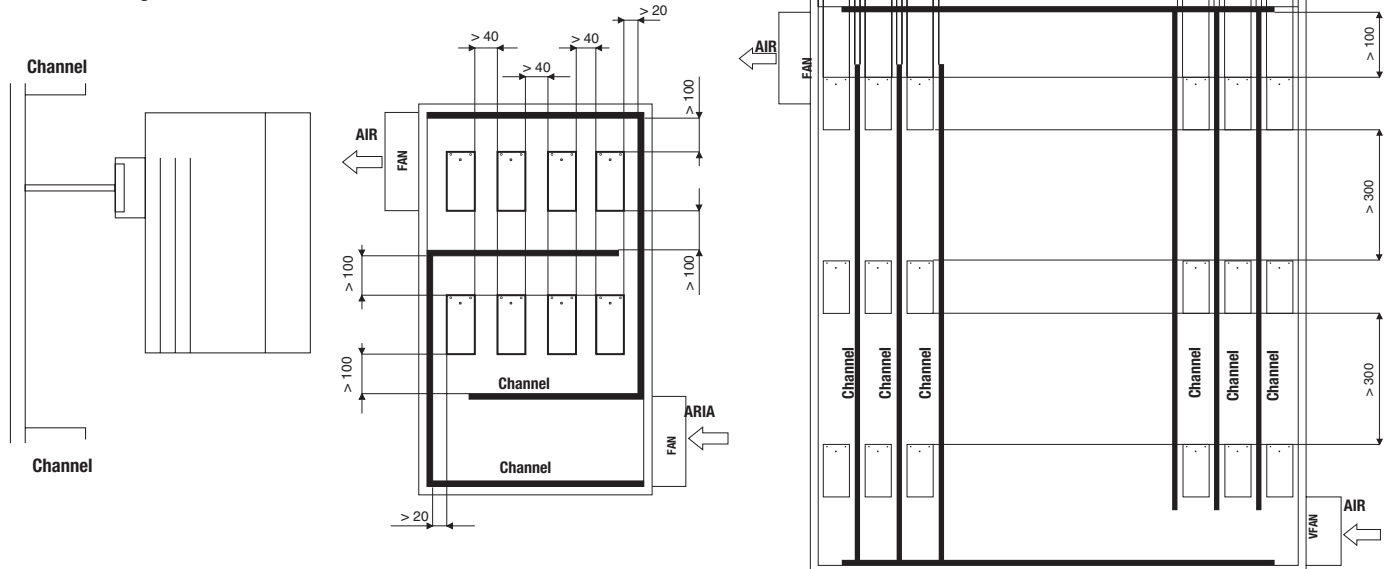

General Application Notes (continued)

Dissipation Curves

Effective current controllable based on room temperature

DIS 25GD

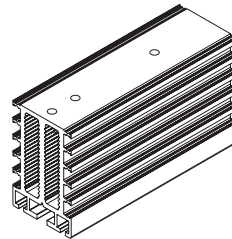
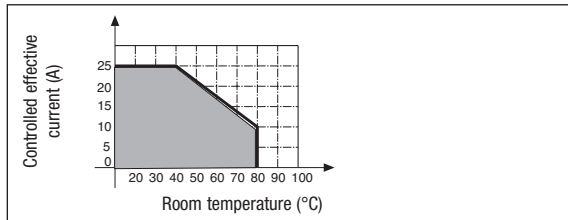

$h = 100\text{mm}$
 $R_{\theta j} = 2.8^{\circ}\text{C/W}$
 (*)

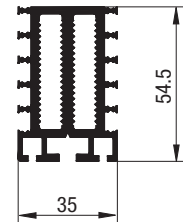

DIS 50G

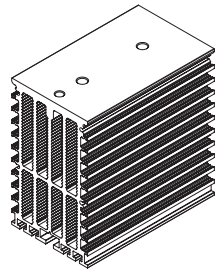
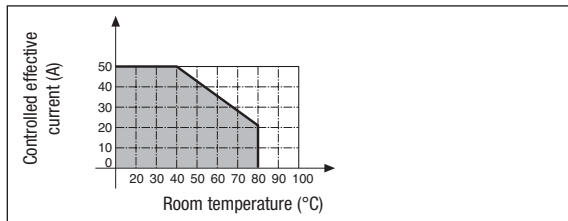

$h = 100\text{mm}$
 $R_{\theta j} = 0.83^{\circ}\text{C/W}$
 (*)

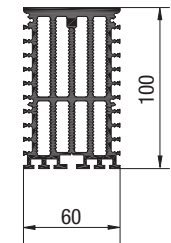

DIS 60G

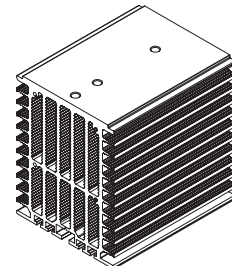
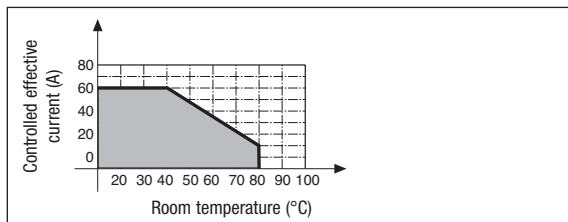

$h = 100\text{mm}$
 $R_{\theta j} = 0.66^{\circ}\text{C/W}$
 (*)

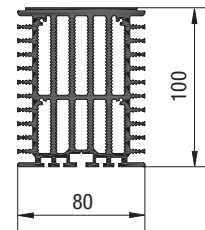

DIS 90G

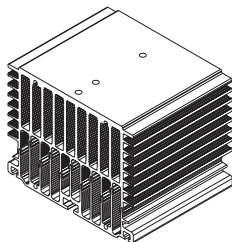
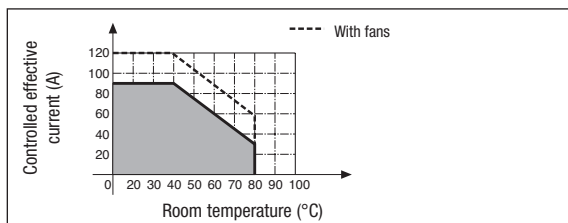

$h = 100\text{mm}$
 $R_{\theta j} = 0.56^{\circ}\text{C/W}$
 (*)

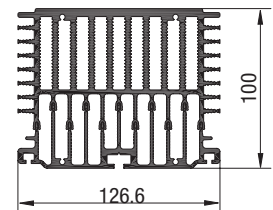

G
Gefran Solid State Relays

General Application Notes (continued)

Varistors (MOV)

If your application is located near inductive loads, or shares power sources with large inductive loads that are creating transients in excess of the blocking voltage of the Gefran solid state relay, then you must install a metal oxide varistor (MOV) to protect the solid state relay. It is up to the installation company to properly size the MOV to the application! Ideally, the MOV protection is near the noise generating inductive load (such as a motor, drive, or other large inductive coil) or you can place MOVs directly across the output terminals of the SSR.

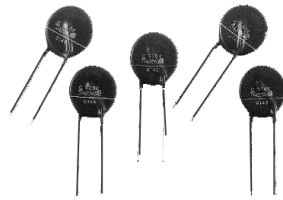

Fuses and Fuse Holders

These fuses ensure the maximum safety in solid state relay applications. Fuses with a very high cutoff power are used for this kind of applications. See Table 1.



Table 1.

Recommended Fuses (by others) for GQ, GTS & GTZ Relays					
Type relay	i ² t	Nominal voltage	Size	Dimensions (mm)	Bussman Part No.
GQ 15A	450	230 480	16A	10x38	FWC16A10F
GTS 25A GQ 25A	645 450	230 480 600	25A	10x38	FWC25A10F
GTS 40A	1010	230 480	40A	14x51	FWP40A14
GTS 50A GQ 50A	6600	230 480 600	63A	22x58	FWP63A22F
GTS 60A	6600	230 480 600	80A	22x58	FWP80A22F
GTS 75A	8000	230 480	80A	22x58	FWP80A22F
GTS 90A GQ 90A	11200	230 480 600	100A	22x58	FWP100A22F
GTS 120A	11200	230 480 600	125A	0-0-0-TN/80 100x51x30	170M1418000-TN/80
GTZ 25A	450 645	400 480	25A	12x32	FWC25A10F
GTZ 40A	1010	480 600	40A	14x51	FWP40A14
GTZ 55A	6600	480 600	63A	22x58	FWP63A22F

(*) PF for fuseholders: LEGRAND, PFI for fuseholders: ITALWEBER

Recommended MOVs from EPCOS:

Part Number	Working Voltage (V)
S20K300	120-290 V AC
S20K420	291-400 V AC
S20K510	401-500 V AC

The Gefran solid state relays include technology that dramatically reduces your need to install an external MOV except in extremely noisy environments or inductive load applications.

General Application Notes (continued)

Series GQ Installation notes

- The heat sink must be grounded.
- Power controllers are designed to assure a switching function that does not include protection of the load line or of devices connected to it. The customer must provide all necessary safety and protection devices in conformity to current electrical standards and regulations.
- Protect the solid state relay by using an appropriate heat sink (accessory). The heat sink must be sized according to room temperature and load current.

Dissipated Power Calculation

Single-phase relay

$P_d \text{ GQ..15/25} = 1.45 * I_{RMS} [W]$

$P_d \text{ GQ..50/90} = 1.35 * I_{RMS} [W]$

I_{RMS} = single-phase load current

Heatsink Thermal Resistance Calculation

$R_{th} = (90^\circ C - \text{max amb. } T) / P_d$

- where P_d = dissipated power
- Max. amb. T = max air temperature inside the electrical cabinet.

Use a heatsink with thermal resistance inferior to the calculated one (R_{th}).

Maximum surrounding air temperature $40^\circ C$ suitable for use in pollution degree 2 or better.

Procedure for mounting on heat sink:

The module-heat sink contact surface must have a maximum planarity error of 0.05mm. and maximum roughness of 0.02mm. The fastening holes on the heat sink must be threaded and countersunk.

Attention: spread 1 gram of thermoconductive silicone (we recommend DOW CORNING 340 HeatSink) on the dissipative metal surface of the module. The surfaces must be clean and there must be no impurities in the thermoconductive paste. As alternative it is also possible to use the graphite film SIL-GQ available as accessory.

- Alternately tighten the two fastening screws until reaching a torque of 0.4...0.6 Nm. Wait 5 minutes for any excess paste to drain.
- Alternately tighten the two fastening screws until reaching a torque of 1.2...1.4 Nm.

Installation on sink:

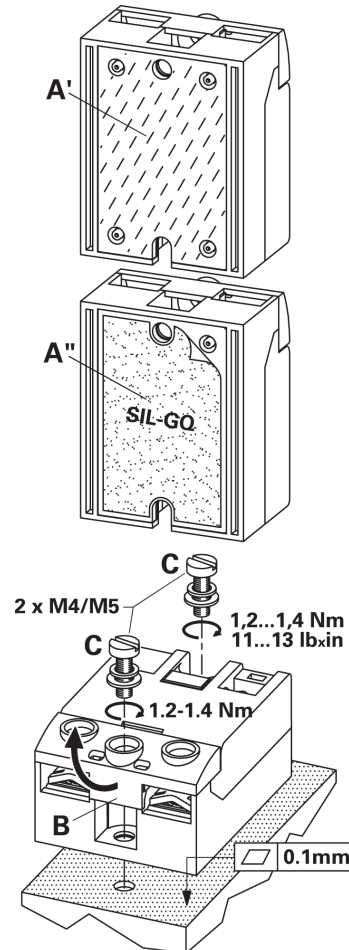

General Application Notes (continued)

Series GTS Installation notes

Power controllers are designed to assure a switching function that does not include protection of the load line or of devices connected to it. The customer must provide all necessary safety and protection devices in conformity to current electrical standards and regulations.

To assure maximum reliability, it is essential to install the unit correctly in the panel in order to guarantee adequate heat exchange between the heat sink and the room under natural convection conditions.

Maximum surrounding air temperature 40°C “Open Type Equipment” suitable for use in pollution degree 2 or better.

Install the unit vertically (max 10° inclination from vertical axis).

- Vertical distance between unit and panel wall >100 mm
- Horizontal distance between unit and panel wall at least 20 mm
- Vertical distance between one unit and the next at least 300 mm
- Horizontal distance between one unit and the next at least 20 mm

Make sure that the wire raceways do not reduce such distances. If they do, install the units cantilevered to the panel so that air can flow vertically onto the heat sink without obstruction.

Equipment should be short circuit protected by semiconductor fuse type:

Model	Fuse manufacturer	Fuse Model size
GTS 15/230	Bussmann Div Cooper (UK) Ltd	FWC16A10F 10x38
GTS 25/480		FWC25A10F 10x38
GTS 40/230, GTS 40/480		FWP40A14F 14x51
GTS 50/230, GTS 50/480		FWP63A22F 22x58
GTS 60/230, GTS 60/480, GTS 75/230, GTS 75/480		FWP80A22F 22x58
GTS 90/230, GTS 90/480		FWP100A22F 22x58
GTS 120/230, GTS 120/480	Bussmann Intrn'l Inc. USA	170M1418 000-TN/80

Series GTZ Installation notes

Power controllers are designed to assure a switching function that does not include protection of the load line or of devices connected to it. The customer must provide all necessary safety and protection devices in conformity to current electrical standards and regulations.

To assure maximum reliability, it is essential to install the unit correctly in the panel in order to guarantee adequate heat exchange between the heat sink and the room under natural convection conditions.

Install the unit vertically (max 10° inclination from vertical axis).

- Vertical distance between a heatsink and panel wall >100 mm
- Horizontal distance between a heatsink and panel wall at least 20 mm
- Vertical distance between two heatsink at least 300 mm
- Horizontal distance between two heatsink at least 20 mm

Make sure that the cable raceways do not reduce such distances. If they do, install the GTZ overhanging from the panel, so that the air can flow vertically on the heatsink without obstruction.

General Application Notes *(continued)*

Warnings

During continuous operation, the heat sink can reach very high temperatures, and keeps a high temperature even after the unit is turned off due to its high thermic inertia.



DO NOT work on the power section without first cutting out electrical power to the panel.



Follow the instructions in the technical manual.

