

**Features**

- Advanced Process Technology
- Ultra Low On-Resistance
- 175°C Operating Temperature
- Fast Switching
- Repetitive Avalanche Allowed up to Tjmax
- Lead-Free

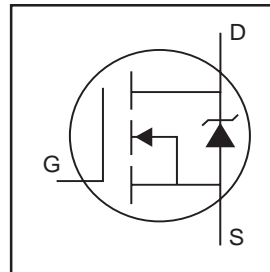

|                           |
|---------------------------|
| $V_{DSS} = 40V$           |
| $R_{DS(on)} = 9.0m\Omega$ |
| $I_D = 42A$               |

**Description**

Specifically designed for Automotive applications, this HEXFET® Power MOSFET utilizes the latest processing techniques to achieve extremely low on-resistance per silicon area. Additional features of this design are a 175°C junction operating temperature, fast switching speed and improved repetitive avalanche rating. These features combine to make this design an extremely efficient and reliable device for use in Automotive applications and a wide variety of other applications.

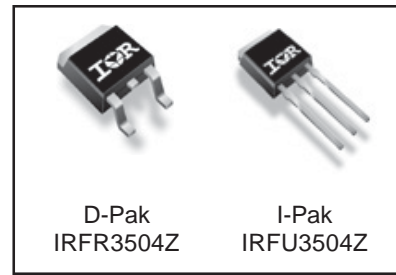

**Absolute Maximum Ratings**

|                              | Parameter  | Max.                     | Units |
|------------------------------|--|--------------------------|-------|
| $I_D @ T_C = 25^\circ C$     | Continuous Drain Current, $V_{GS} @ 10V$ (Silicon Limited) | 77                       | A     |
| $I_D @ T_C = 100^\circ C$    | Continuous Drain Current, $V_{GS} @ 10V$                   | 54                       |       |
| $I_D @ T_C = 25^\circ C$     | Continuous Drain Current, $V_{GS} @ 10V$ (Package Limited) | 42                       |       |
| $I_{DM}$                     | Pulsed Drain Current ①                                     | 310                      |       |
| $P_D @ T_C = 25^\circ C$     | Power Dissipation  | 90                       | W     |
|                              | Linear Derating Factor                                     | 0.60                     | W/°C  |
| $V_{GS}$                     | Gate-to-Source Voltage                                     | $\pm 20$                 | V     |
| $E_{AS}$ (Thermally limited) | Single Pulse Avalanche Energy ②                            | 77                       | mJ    |
| $E_{AS}$ (Tested )           | Single Pulse Avalanche Energy Tested Value ③               | 110                      |       |
| $I_{AR}$                     | Avalanche Current ④  | See Fig.12a, 12b, 15, 16 | A     |
| $E_{AR}$                     | Repetitive Avalanche Energy ⑤                              |                          | mJ    |
| $T_J$                        | Operating Junction and                                     | -55 to + 175             | °C    |
| $T_{STG}$                    | Storage Temperature Range                                  |                          |       |
|                              | Soldering Temperature, for 10 seconds                      | 300 (1.6mm from case )   |       |
|                              | Mounting Torque, 6-32 or M3 screw                          | 10 lbf•in (1.1N•m)       |       |

**Thermal Resistance**

|                 | Parameter                         | Typ. | Max. | Units |
|-----------------|-----------------------------------|------|------|-------|
| $R_{\theta JC}$ | Junction-to-Case                  | —    | 1.66 | °C/W  |
| $R_{\theta JA}$ | Junction-to-Ambient (PCB mount) ⑥ | —    | 40   |       |
| $R_{\theta JA}$ | Junction-to-Ambient               | —    | 110  |       |

HEXFET® is a registered trademark of International Rectifier.

## Electrical Characteristics @ T<sub>J</sub> = 25°C (unless otherwise specified)

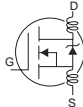
|  | Parameter                            | Min. | Typ.  | Max. | Units | Conditions  |
|--|--------------------------------------|------|-------|------|-------|---|
| V <sub>(BR)DSS</sub>                   | Drain-to-Source Breakdown Voltage    | 40   | —     | —    | V     | V <sub>GS</sub> = 0V, I <sub>D</sub> = 250μA  |
| ΔV <sub>(BR)DSS</sub> /ΔT <sub>J</sub> | Breakdown Voltage Temp. Coefficient  | —    | 0.032 | —    | V/°C  | Reference to 25°C, I <sub>D</sub> = 1mA   |
| R <sub>DS(on)</sub>                    | Static Drain-to-Source On-Resistance | —    | 8.23  | 9.0  | mΩ    | V <sub>GS</sub> = 10V, I <sub>D</sub> = 42A ③   |
| V <sub>GS(th)</sub>                    | Gate Threshold Voltage               | 2.0  | —     | 4.0  | V     | V <sub>DS</sub> = V <sub>GS</sub> , I <sub>D</sub> = 250μA                            |
| g <sub>fs</sub>                        | Forward Transconductance             | 32   | —     | —    | S     | V <sub>DS</sub> = 10V, I <sub>D</sub> = 42A   |
| I <sub>DSS</sub>                       | Drain-to-Source Leakage Current      | —    | —     | 20   | μA    | V <sub>DS</sub> = 40V, V <sub>GS</sub> = 0V   |
|  |                                      | —    | —     | 250  |       | V <sub>DS</sub> = 40V, V <sub>GS</sub> = 0V, T <sub>J</sub> = 125°C                   |
| I <sub>GSS</sub>                       | Gate-to-Source Forward Leakage       | —    | —     | 200  | nA    | V <sub>GS</sub> = 20V   |
|  | Gate-to-Source Reverse Leakage       | —    | —     | -200 |       | V <sub>GS</sub> = -20V  |
| Q <sub>g</sub>                         | Total Gate Charge                    | —    | 30    | 45   | nC    | I <sub>D</sub> = 42A  |
| Q <sub>gs</sub>                        | Gate-to-Source Charge                | —    | 9.6   | —    |       | V <sub>DS</sub> = 32V   |
| Q <sub>gd</sub>                        | Gate-to-Drain ("Miller") Charge      | —    | 12    | —    |       | V <sub>GS</sub> = 10V ③   |
| t <sub>d(on)</sub>                     | Turn-On Delay Time                   | —    | 15    | —    | ns    | V <sub>DD</sub> = 20V   |
| t <sub>r</sub>                         | Rise Time                            | —    | 74    | —    |       | I <sub>D</sub> = 42A  |
| t <sub>d(off)</sub>                    | Turn-Off Delay Time                  | —    | 30    | —    |       | R <sub>G</sub> = 15 Ω   |
| t <sub>f</sub>                         | Fall Time                            | —    | 38    | —    |       | V <sub>GS</sub> = 10V ③   |
| L <sub>D</sub>                         | Internal Drain Inductance            | —    | 4.5   | —    | nH    | Between lead,<br>6mm (0.25in.)<br>from package<br>and center of die contact           |
| L <sub>S</sub>                         | Internal Source Inductance           | —    | 7.5   | —    |       |  |
| C <sub>iss</sub>                       | Input Capacitance                    | —    | 1510  | —    | pF    | V <sub>GS</sub> = 0V  |
| C <sub>oss</sub>                       | Output Capacitance                   | —    | 340   | —    |       | V <sub>DS</sub> = 25V   |
| C <sub>rss</sub>                       | Reverse Transfer Capacitance         | —    | 190   | —    |       | f = 1.0MHz  |
| C <sub>oss</sub>                       | Output Capacitance                   | —    | 1100  | —    |       | V <sub>GS</sub> = 0V, V <sub>DS</sub> = 1.0V, f = 1.0MHz                              |
| C <sub>oss</sub>                       | Output Capacitance                   | —    | 340   | —    |       | V <sub>GS</sub> = 0V, V <sub>DS</sub> = 32V, f = 1.0MHz                               |
| C <sub>oss eff.</sub>                  | Effective Output Capacitance         | —    | 460   | —    |       | V <sub>GS</sub> = 0V, V <sub>DS</sub> = 0V to 32V ④                                   |

## Source-Drain Ratings and Characteristics

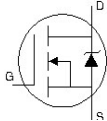
|                 | Parameter                                 | Min.   | Typ. | Max. | Units | Conditions  |
|-----------------|---|--|------|------|-------|---|
| I <sub>S</sub>  | Continuous Source Current<br>(Body Diode) | —  | —    | 42   | A     | MOSFET symbol<br>showing the<br>integral reverse<br>p-n junction diode.               |
| I <sub>SM</sub> | Pulsed Source Current<br>(Body Diode) ①   | —  | —    | 310  |       |  |
| V <sub>SD</sub> | Diode Forward Voltage                     | —  | —    | 1.3  | V     | T <sub>J</sub> = 25°C, I <sub>S</sub> = 42A, V <sub>GS</sub> = 0V ③                   |
| t <sub>rr</sub> | Reverse Recovery Time                     | —  | 18   | 27   | ns    | T <sub>J</sub> = 25°C, I <sub>F</sub> = 42A, V <sub>DD</sub> = 20V                    |
| Q <sub>rr</sub> | Reverse Recovery Charge                   | —  | 9.2  | 14   | nC    | di/dt = 100A/μs ③   |
| t <sub>on</sub> | Forward Turn-On Time                      | Intrinsic turn-on time is negligible (turn-on is dominated by LS+LD) |      |      |       |   |

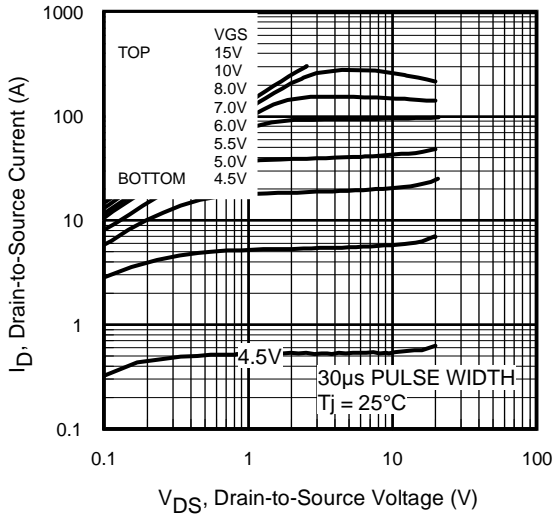

**Fig 1.** Typical Output Characteristics

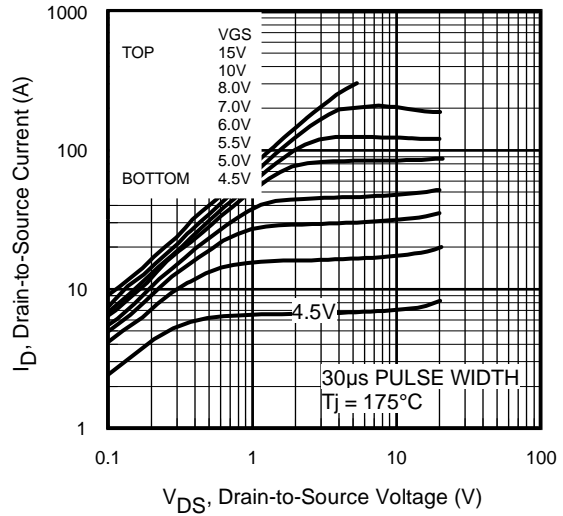

**Fig 2.** Typical Output Characteristics

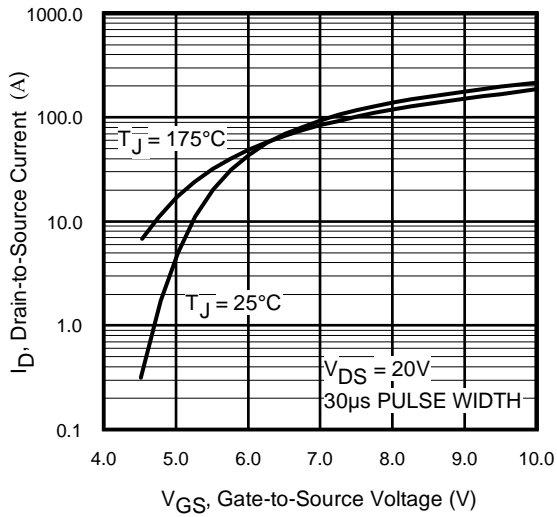

**Fig 3.** Typical Transfer Characteristics

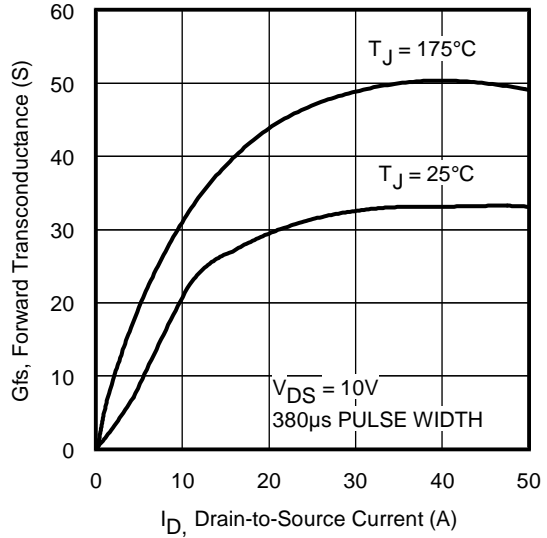

**Fig 4.** Typical Forward Transconductance Vs. Drain Current

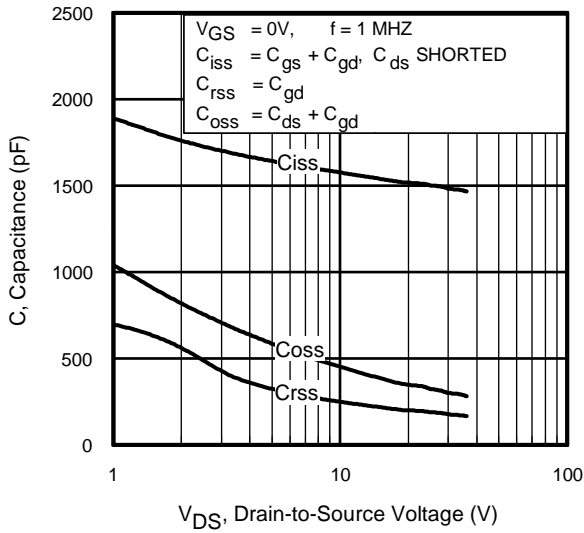

**Fig 5.** Typical Capacitance Vs. Drain-to-Source Voltage

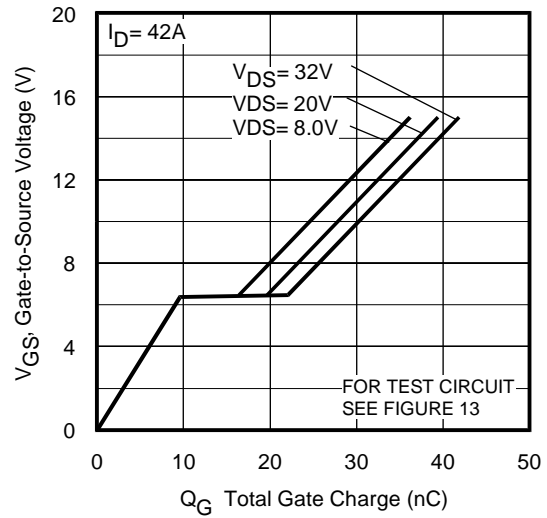

**Fig 6.** Typical Gate Charge Vs. Gate-to-Source Voltage

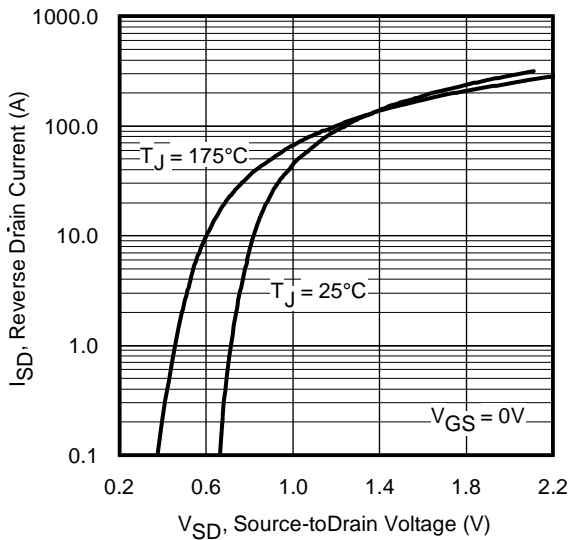

**Fig 7.** Typical Source-Drain Diode Forward Voltage

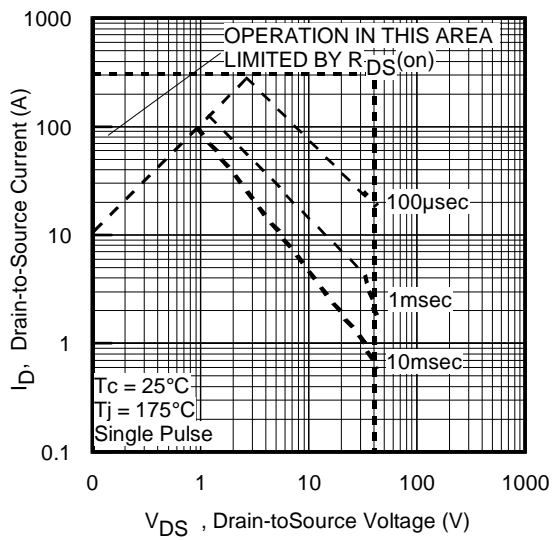

**Fig 8.** Maximum Safe Operating Area

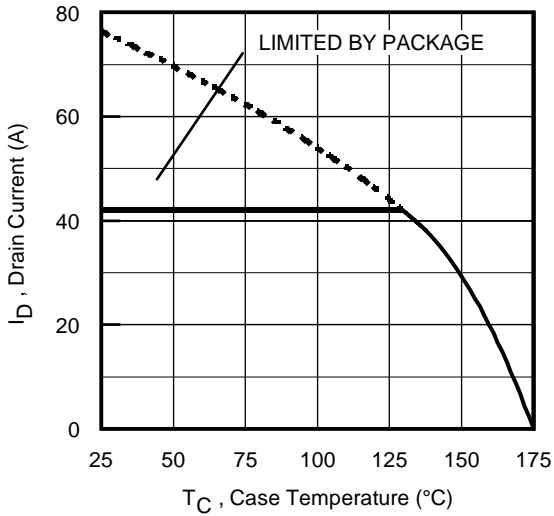

**Fig 9.** Maximum Drain Current Vs. Case Temperature

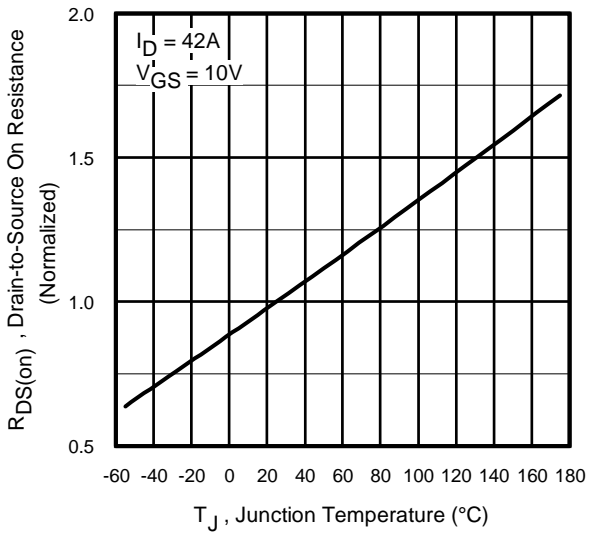

**Fig 10.** Normalized On-Resistance Vs. Temperature

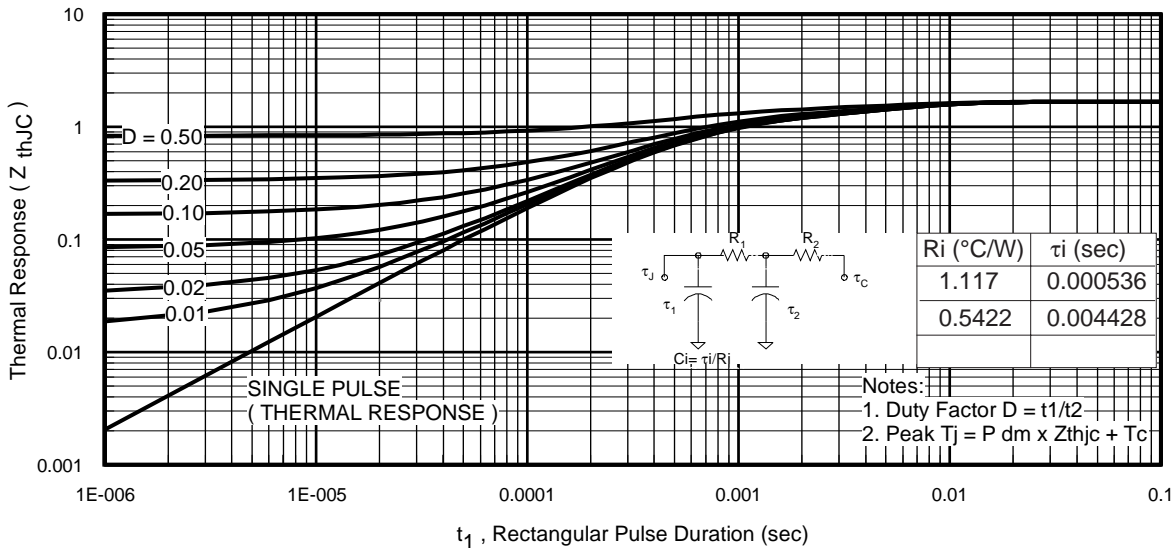

**Fig 11.** Maximum Effective Transient Thermal Impedance, Junction-to-Case

# IRFR/U3504ZPbF

International  
**IR** Rectifier

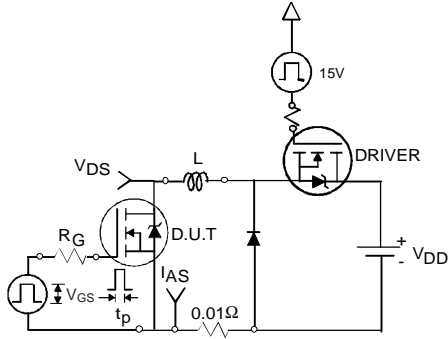

**Fig 12a.** Unclamped Inductive Test Circuit

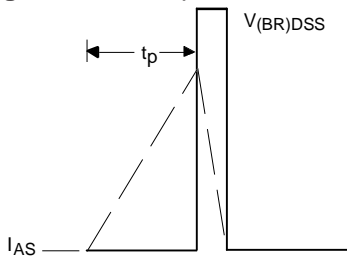

**Fig 12b.** Unclamped Inductive Waveforms

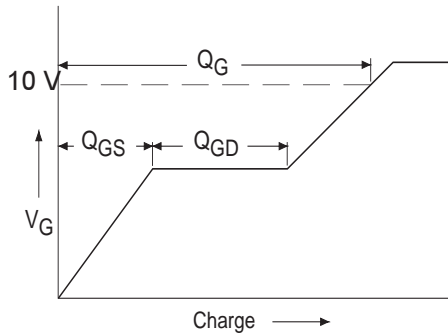

**Fig 13a.** Basic Gate Charge Waveform

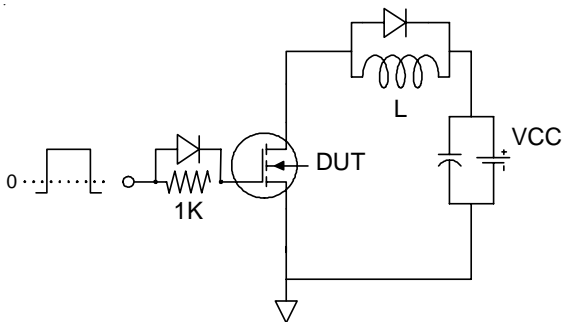

**Fig 13b.** Gate Charge Test Circuit

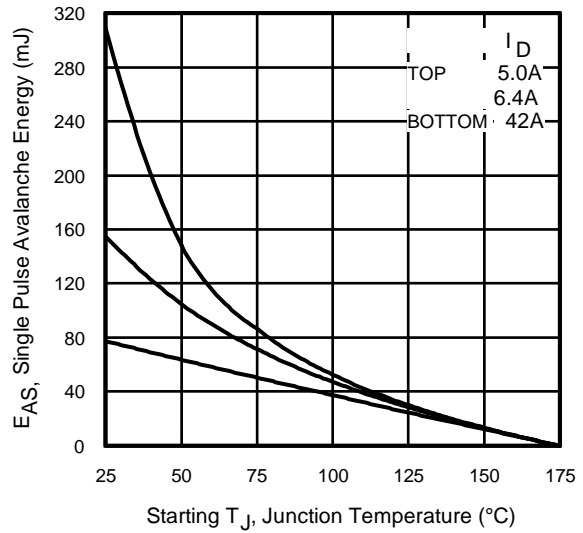

**Fig 12c.** Maximum Avalanche Energy Vs. Drain Current

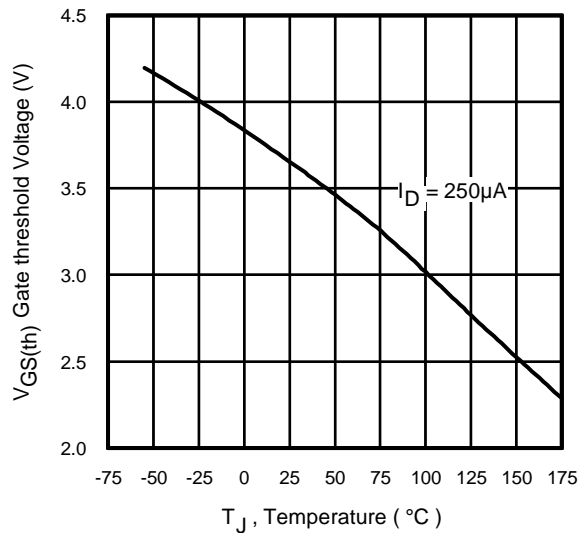

**Fig 14.** Threshold Voltage Vs. Temperature

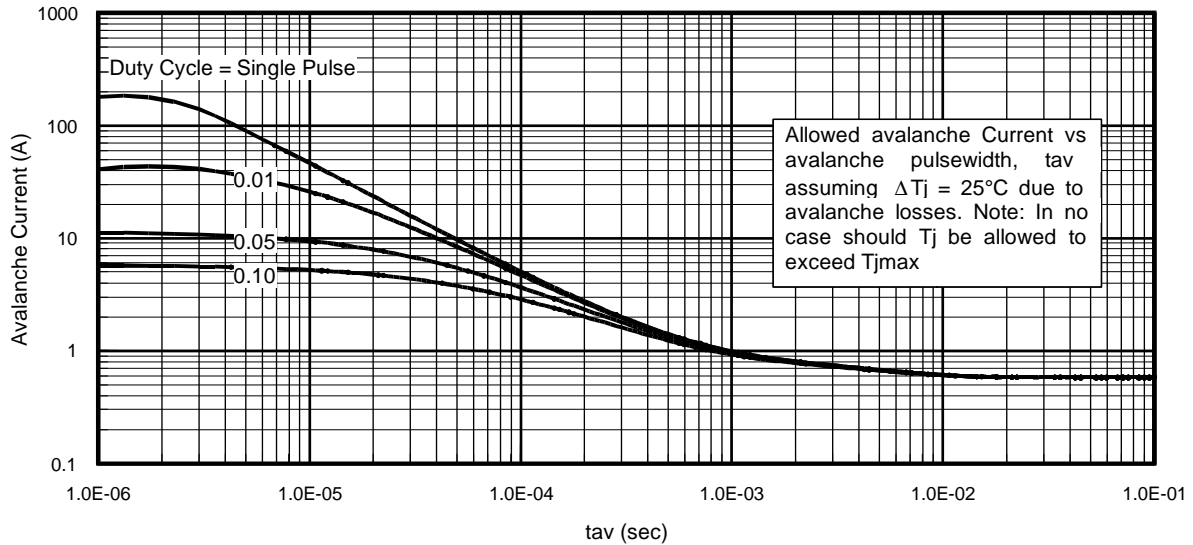

Fig 15. Typical Avalanche Current Vs.Pulsewidth

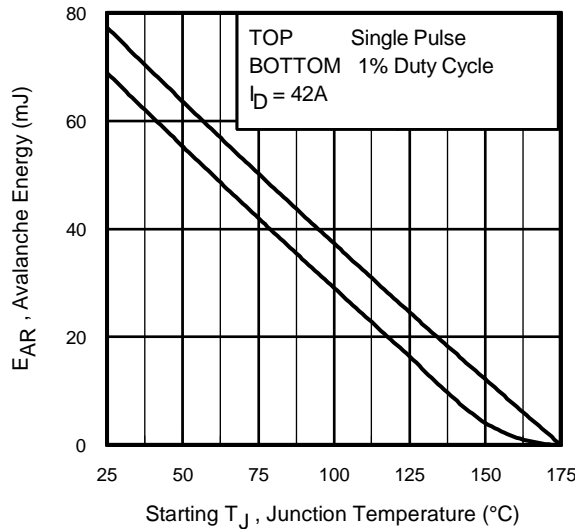

Fig 16. Maximum Avalanche Energy Vs. Temperature

**Notes on Repetitive Avalanche Curves , Figures 15, 16:**  
(For further info, see AN-1005 at [www.irf.com](http://www.irf.com))

1. Avalanche failures assumption:  
Purely a thermal phenomenon and failure occurs at a temperature far in excess of  $T_{jmax}$ . This is validated for every part type.
2. Safe operation in Avalanche is allowed as long as  $T_{jmax}$  is not exceeded.
3. Equation below based on circuit and waveforms shown in Figures 12a, 12b.
4.  $P_{D(ave)}$  = Average power dissipation per single avalanche pulse.
5.  $BV$  = Rated breakdown voltage (1.3 factor accounts for voltage increase during avalanche).
6.  $I_{av}$  = Allowable avalanche current.
7.  $\Delta T$  = Allowable rise in junction temperature, not to exceed  $T_{jmax}$  (assumed as 25°C in Figure 15, 16).  
 $t_{av}$  = Average time in avalanche.  
 $D$  = Duty cycle in avalanche =  $t_{av} \cdot f$   
 $Z_{thJC}(D, t_{av})$  = Transient thermal resistance, see figure 11)

$$P_{D(ave)} = 1/2 ( 1.3 \cdot BV \cdot I_{av} ) = \Delta T / Z_{thJC}$$

$$I_{av} = 2\Delta T / [1.3 \cdot BV \cdot Z_{th}]$$

$$E_{AS(AR)} = P_{D(ave)} \cdot t_{av}$$

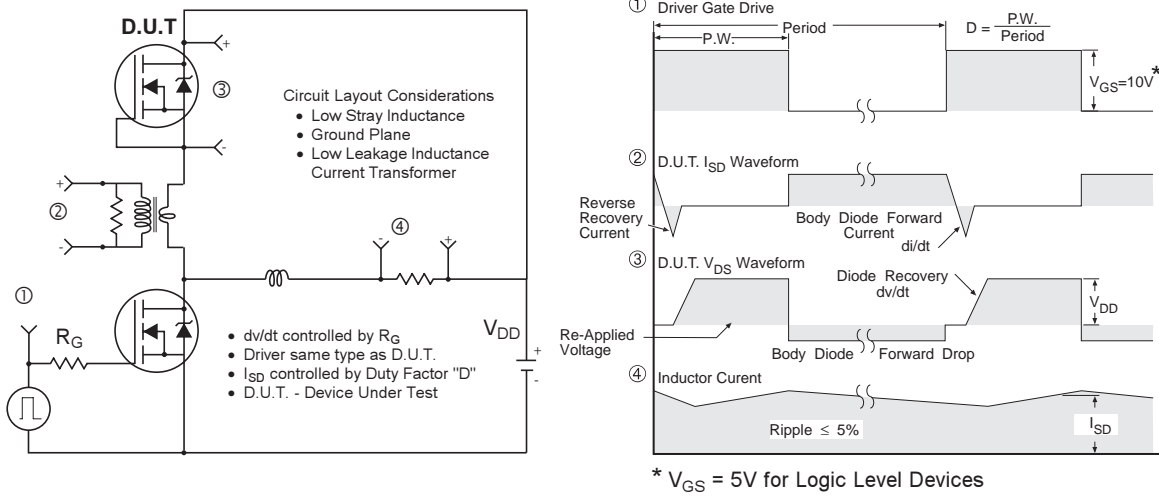

**Fig 17. Peak Diode Recovery  $dv/dt$  Test Circuit for N-Channel HEXFET® Power MOSFETs**

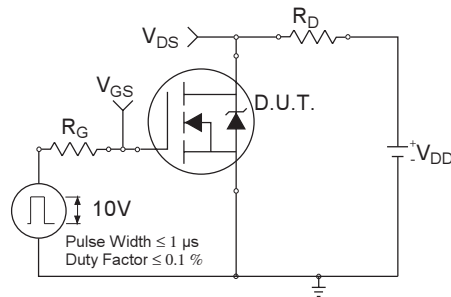

**Fig 18a. Switching Time Test Circuit**

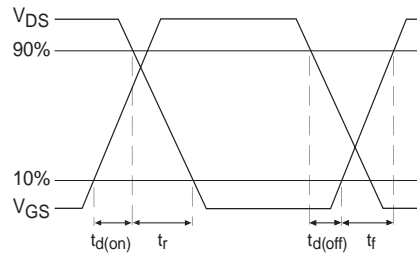

**Fig 18b. Switching Time Waveforms**

## D-Pak (TO-252AA) Package Outline

Dimensions are shown in millimeters (inches)

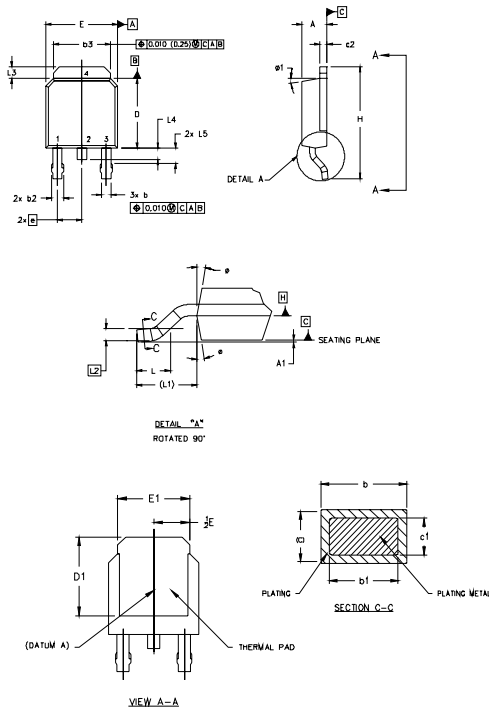

**NOTES:**

- 1.0 DIMENSIONING AND TOLERANCING PER ASME Y14.5 M- 1994.
- 2.0 DIMENSIONS ARE SHOWN IN INCHES [MILLIMETERS].
- 3.0 LEAD DIMENSION UNCONTROLLED IN L5
- 4.0 DIMENSION D1 AND E1 ESTABLISH A MINIMUM MOUNTING SURFACE FOR THERMAL PAD.
- 5.0 SECTION C-C DIMENSIONS APPLY TO THE FLAT SECTION OF THE LEAD BETWEEN .005 [0.127] AND .010 [0.2540] FROM THE LEAD TIP.
- 6.0 DIMENSION D & E DO NOT INCLUDE MOLD FLASH. MOLD FLASH SHALL NOT EXCEED .005" (0.127) PER SIDE. THESE DIMENSIONS ARE MEASURED AT THE OUTERMOST EXTREMES OF THE PLASTIC BODY.
- 7.0 OUTLINE CONFORMS TO JEDEC OUTLINE TO-252AA.

| SYMBOL | DIMENSIONS  |       |           |       | NOTES |
|--------|-------------|-------|-----------|-------|-------|
|        | MILLIMETERS |       | INCHES    |       |       |
|        | MIN.        | MAX.  | MIN.      | MAX.  |       |
| A      | 2.18        | 2.39  | .086      | .094  |       |
| A1     |             | 0.13  |           | .005  |       |
| b      | 0.64        | 0.89  | .025      | .036  | 5     |
| b1     | 0.64        | 0.79  | .025      | 0.031 | 5     |
| b2     | 0.76        | 1.14  | .030      | .045  |       |
| b3     | 4.95        | 5.46  | .195      | .215  |       |
| c      | 0.46        | 0.61  | .018      | .024  | 5     |
| c1     | 0.41        | 0.56  | .016      | .022  | 5     |
| c2     | .046        | 0.89  | .018      | .035  | 5     |
| D      | 5.97        | 6.22  | .235      | .245  | 6     |
| D1     | 5.21        | -     | .205      | -     | 4     |
| E      | 6.35        | 6.73  | .250      | .265  | 6     |
| E1     | 4.32        | -     | .170      | -     | 4     |
| e      | 2.29        |       | .090 BSC  |       |       |
| H      | 9.40        | 10.41 | .370      | .410  |       |
| L      | 1.40        | 1.78  | .055      | .070  |       |
| L1     | 2.74 REF.   |       | .108 REF. |       |       |
| L2     | 0.051 BSC   |       | .020 BSC  |       |       |
| L3     | 0.89        | 1.27  | .035      | .050  |       |
| L4     |             | 1.02  |           | .040  |       |
| L5     | 1.14        | 1.52  | .045      | .060  |       |
| ø      | 0"          | 10"   | 0"        | 10"   | 3     |
| ø1     | 0"          | 15"   | 0"        | 15"   |       |

LEAD ASSIGNMENTS

HEXFET

- 1.- GATE
- 2.- DRAIN
- 3.- SOURCE
- 4.- DRAIN

IGBTs, CoPACK

- 1.- GATE
- 2.- COLLECTOR
- 3.- EMITTER
- 4.- COLLECTOR

## D-Pak (TO-252AA) Part Marking Information

EXAMPLE: THIS IS AN IRFR120  
WITH ASSEMBLY  
LOT CODE 1234  
ASSEMBLED ON WW 16, 1999  
IN THE ASSEMBLY LINE "A"

Note: "P" in assembly line position  
indicates "Lead-Free"

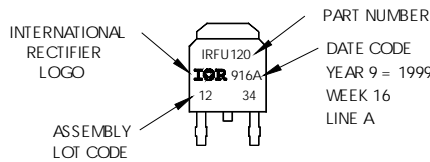

OR

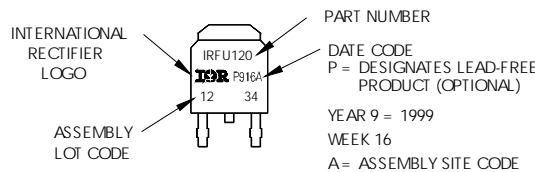

# IRFR/U3504ZPbF

International  
**IR** Rectifier

## I-Pak (TO-251AA) Package Outline

Dimensions are shown in millimeters (inches)

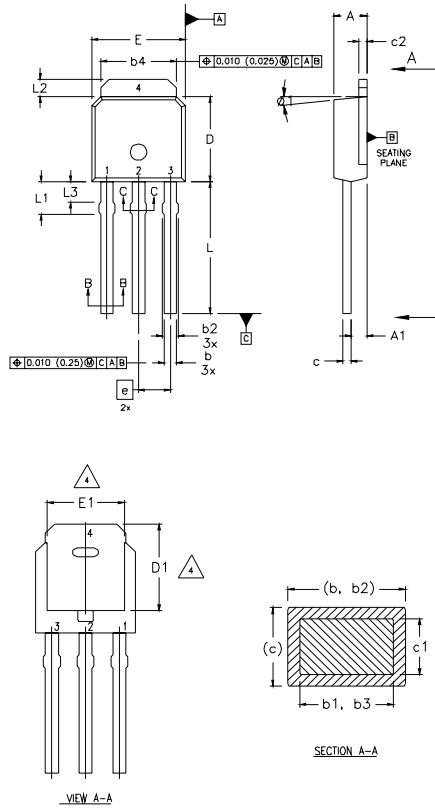

### NOTES:

- 1 DIMENSIONING AND TOLERANCING PER ASME Y14.5 M- 1994.
- 2 DIMENSIONS ARE SHOWN IN MILLIMETERS [INCHES].
- 3 DIMENSION D & E DO NOT INCLUDE MOLD FLASH. MOLD FLASH SHALL NOT EXCEED 0.005" (0.127) PER SIDE. THESE DIMENSIONS ARE MEASURED AT THE OUTERMOST EXTREMES OF THE PLASTIC BODY.
- 4 THERMAL PAD CONTOUR OPTION WITHIN DIMENSION b4, L2, E1 & D1.
- 5 LEAD DIMENSION UNCONTROLLED IN L3.
- 6 DIMENSION b1, b3 APPLY TO BASE METAL ONLY.
- 7 OUTLINE CONFORMS TO JEDEC OUTLINE TO-251AA.
- 8 CONTROLLING DIMENSION : INCHES.

### LEAD ASSIGNMENTS

#### HEXFET

- 1.- GATE
- 2.- DRAIN
- 3.- SOURCE
- 4.- DRAIN

| SYMBOL | DIMENSIONS  |      |           |       | NOTES |
|--------|-------------|------|-----------|-------|-------|
|        | MILLIMETERS |      | INCHES    |       |       |
|        | MIN.        | MAX. | MIN.      | MAX.  |       |
| A      | 2.18        | 2.39 | 0.086     | .094  |       |
| A1     | 0.89        | 1.14 | 0.035     | 0.045 |       |
| b      | 0.64        | 0.89 | 0.025     | 0.035 |       |
| b1     | 0.64        | 0.79 | 0.025     | 0.031 | 4     |
| b2     | 0.76        | 1.14 | 0.030     | 0.045 |       |
| b3     | 0.76        | 1.04 | 0.030     | 0.041 |       |
| b4     | 5.00        | 5.46 | 0.195     | 0.215 | 4     |
| c      | 0.46        | 0.61 | 0.018     | 0.024 |       |
| c1     | 0.41        | 0.56 | 0.016     | 0.022 |       |
| c2     | .046        | 0.86 | 0.018     | 0.035 |       |
| D      | 5.97        | 6.22 | 0.235     | 0.246 | 3, 4  |
| D1     | 5.21        | -    | 0.205     | -     | 4     |
| E      | 6.35        | 6.73 | 0.250     | 0.265 | 3, 4  |
| E1     | 4.32        | -    | 0.170     | -     | 4     |
| e      | 2.29        |      | 0.090 BSC |       |       |
| L      | 8.89        | 9.60 | 0.350     | 0.380 |       |
| L1     | 1.91        | 2.29 | 0.075     | 0.090 |       |
| L2     | 0.89        | 1.27 | 0.035     | 0.050 | 4     |
| L3     | 1.14        | 1.52 | 0.045     | 0.060 | 5     |
| ø1     | 0"          | 15"  | 0"        | 15"   |       |

## I-Pak (TO-251AA) Part Marking Information

EXAMPLE: THIS IS AN IRFU120  
WITH ASSEMBLY  
LOT CODE 5678  
ASSEMBLED ON WW 19, 1999  
IN THE ASSEMBLY LINE "A"  
**Note:** "P" in assembly line  
position indicates "Lead-Free"

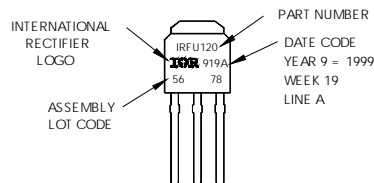

OR

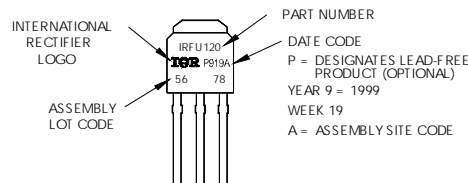

## D-Pak (TO-252AA) Tape & Reel Information

Dimensions are shown in millimeters (inches)

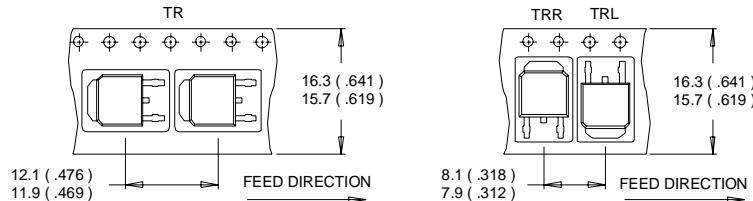

- NOTES :
1. CONTROLLING DIMENSION : MILLIMETER.
  2. ALL DIMENSIONS ARE SHOWN IN MILLIMETERS ( INCHES ).
  3. OUTLINE CONFORMS TO EIA-481 & EIA-541.

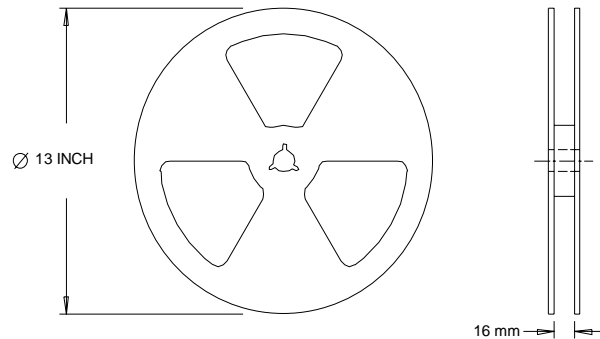

- NOTES :
1. OUTLINE CONFORMS TO EIA-481.

**Notes:**

- ① Repetitive rating; pulse width limited by max. junction temperature. (See fig. 11).
- ② Limited by  $T_{Jmax}$ ; starting  $T_J = 25^\circ\text{C}$ ,  $L = 0.09\text{mH}$ ,  $R_G = 25\Omega$ ,  $I_{AS} = 42\text{A}$ ,  $V_{GS} = 10\text{V}$ . Part not recommended for use above this value.
- ③ Pulse width  $\leq 1.0\text{ms}$ ; duty cycle  $\leq 2\%$ .
- ④  $C_{OSS}$  eff. is a fixed capacitance that gives the same charging time as  $C_{OSS}$  while  $V_{DS}$  is rising from 0 to 80%  $V_{DSS}$ .
- ⑤ Limited by  $T_{Jmax}$ , see Fig.12a, 12b, 15, 16 for typical repetitive avalanche performance.
- ⑥ This value determined from sample failure population. 100% tested to this value in production.
- ⑦ When mounted on 1" square PCB (FR-4 or G-10 Material). For recommended footprint and soldering techniques refer to application note #AN-994

Data and specifications subject to change without notice.  
 This product has been designed and qualified for the Automotive [Q101] market.  
 Qualification Standards can be found on IR's Web site.