

SPECIFICATIONS	
CONTACT CARRIER MATERIAL	TPU OR NYLON
MOLDED HEAD MATERIAL/COLOR	TPU/BLACK
CONTACT MATERIAL/PLATING	BRASS/GOLD
COUPLING NUT MATERIAL/PLATING	BRASS/NICKEL
RATED CURRENT [A]	4.0 A
RATED VOLTAGE [V]	250 V
OUTER CABLE JACKET MATERIAL/COLOR	PVC/BLACK
CONDUCTOR INSULATION MATERIAL	HDPE
NUMBER OF CONDUCTORS [AWG]	2x20 AWG
DRAIN/SHIELD	22 AWG DRAIN/POLYESTER FOIL SHIELD/BRAID
TEMPERATURE RANGE	-40°C to +80°C (-40°F to +176°F)
PROTECTION CLASS	MEETS NEMA 1,3,4,6P AND IEC IP68

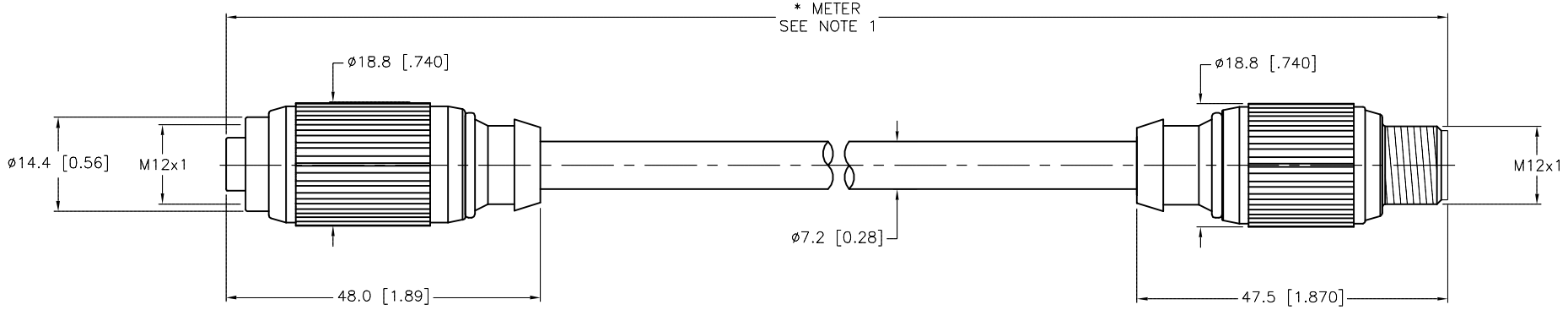

CABLE LENGTH	TOLERANCE*
ALL LENGTHS	+ 4% (OR 50mm) OF LENGTH - 0% (OR 0mm) OF LENGTH WHICHEVER IS GREATER
STRIP LENGTH	TOLERANCE*
0-7mm	±0.5mm
8-29mm	±1.0mm
30-49mm	±2.0mm
50-69mm	±3.0mm
70-100mm	±4.0mm
OVER 100mm	±5.0mm

* UNLESS OTHERWISE SPECIFIED

NOTES:

- "*" INDICATES CABLE LENGTH IN METERS. CONTACT TURCK TO ORDER SPECIFIC LENGTHS.
- "/CS10545" DESIGNATES SPECIAL CABLE AND WIRING. BLACK PLUG BODY.

SOURCE DRAWING - FOR REFERENCE ONLY

RELATED DOCUMENTS	3RD ANGLE PROJECTION	THIS DRAWING IS CONFIDENTIAL AND THE PROPERTY OF TURCK INC. USE OF THIS DOCUMENT WITHOUT WRITTEN PERMISSION IS PROHIBITED.		 3000 CAMPUS DRIVE MINNEAPOLIS, MN 55441 1-800-544-7769 (763) 553-7300 (763) 553-0708 fax turck.com	
1.		DRFT	RWC	DATE	08/11/05
2.		APVD		SCALE	1=1.0
3.	ALL DIMENSIONS DISPLAYED ON THIS DRAWING ARE FOR REFERENCE ONLY	UNIT OF MEASUREMENT		DESCRIPTION	
4.		MILLIMETER [INCH]		RKG 4.2T-*--RSG 4.2T/CS10545	
MATERIAL	CONTACT TURCK FOR MORE INFORMATION	IDENTIFICATION NO.		REV	
SEE SPECIFICATIONS				D	
FINISH	DO NOT SCALE THIS DRAWING	FILE: 777012068		SHEET 1 OF 1	
SEE SPECIFICATIONS					

D	UPDATE CONDUCTOR INSULATION MATERIAL	KMY	09/03/14	44975
REV	DESCRIPTION	BY	DATE	ECO NO.