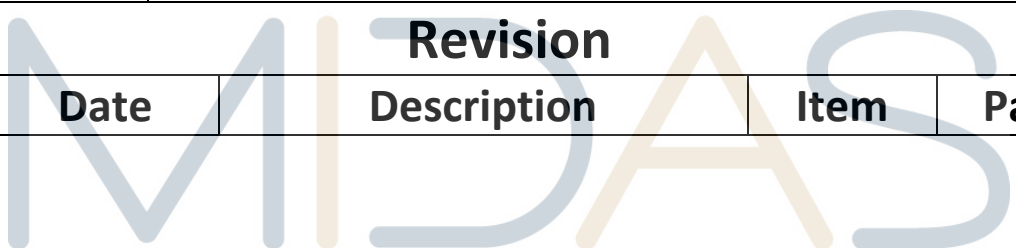

Specification				
Part Number:		MCCOG132064A		
Version:				
Date:				
Revision				
No.	Date	Description	Item	Page
				

Midas LCD Part Number System

MC COG 132033 A * 6 W * * - S N T L W * *
1 2 3 4 5 6 7 8 9 - 10 11 12 13 14 15 16

- 1 = **MC:** Midas Components
- 2 = **Blank:** COB (chip on board) **COG:** chip on glass
- 3 = **No of dots** (e.g. 240064 = 240 x 64 dots) (e.g. 21605 = 2 x 16 5mm C.H.)
- 4 = **Series**
- 5 = **Series Variant:** A to Z – see addendum
- 6 = **3:** 3 o'clock **6:** 6 o'clock **9:** 9 o'clock **12:** 12 o'clock
- 7 = **S:** Normal (0 to + 50 deg C) **W:** Wide temp. (-20 to + 70 deg C) **X:** Extended temp (-30 + 80 Deg C)
- 8 = **Character Set**

Blank: Standard (English/Japanese)
C: Chinese Simplified (Graphic Displays only)
CB: Chinese Big 5 (Graphic Displays only)
H: Hebrew
K: European (std) (English/German/French/Greek)
L: English/Japanese (special)
M: European (English/Scandinavian)
R: Cyrillic
W: European (English/Greek)
U: European (English/Scandinavian/Icelandic)

9 = **Bezel Height** (where applicable /available)

	Top of Bezel to Top of PCB	LED Connection Common (via pins 1 and 2) via pins 15+ 16-	Array or Edge Lit
Blank	9.5mm / not applicable		Array
2	8.9 mm	Common	Array
3	7.8 mm	Separate	Array
4	7.8 mm	Common	Array
5	9.5 mm	Separate	Array
6	7 mm	Common	Array
7	7 mm	Separate	Array
8	6.4 mm	Common	Edge
9	6.4 mm	Separate	Edge
A	5.5 mm	Common	Edge
B	5.5 mm	Separate	Edge
D	6.0mm	Separate	Edge
E	5.0mm	Separate	Edge
F	4.7mm	Common	Edge
G	3.7mm	Separate	EL
H	7 mm	Separate	Edge

- 10 = **T:** TN **S:** STN **B:** STN Blue **G:** STN Grey **F:** FSTN **F2:** FFSTN **V:** VA (Vertically Aligned)
- 11 = **P:** Positive **N:** Negative
- 12 = **R:** Reflective **M:** Transmissive **T:** Transflective
- 13 = **Backlight:** **Blank:** Reflective **L:** LED
- 14 = **Backlight Colour:** **Y:** Yellow-Green **W:** White **B:** Blue **R:** Red **A:** Amber **O:** Orange **G:** Green **RGB:** R.G.B.
- 15 = **Driver Chip:** **Blank:** Standard **I:** I²C **S:** SPI **T:** Toshiba T6963C **A:** Avant SAP1024B **R:** Raio RA6963
- 16 = **Voltage Variant:** e.g. **3** = 3v

LIST

I . General Specifications-----	(4-12)
II . The Characteristics and Reliability Test-----	(13-14)
III. The LCD Measuring Method and Equipment-----	(15-17)
IV. Standard Specifications for Product Quality-----	(18-21)
V . Attached Drawing-----	(22)
VI.Packing -----	(23)
VII. Precautions For Use-----	(24-25)

MIDAS

design • manufacture • supply

I . General Specifications

1. Features

A. Drive Method:Bi-stable display 1/64 Duty, 1/9 Bias

B. The Module Operating Voltage: 3.0V;

C. The LCD Operating Voltage : 30V;

D. Viewing Direction: Free

E. Operating Temperature: 0°C~50°C

F. Storage Temperature: -20°C~70°C

G.Display Technology Description:

Bi-stable display is a reflective LCD with extremely low power consumption characteristics. Due to the non-volatile memory feature of the technology, zero power is required to retain the image of the display. Energy is only required to change the displayed image. No backlighting is required, only ambient lighting from the surrounding is required. Readability when under direct sunlight is excellent and good contrast from viewing at very wide angles are possible.

2. Mechanical Data:

(1) Module Size ----- 70.5(w) * 44.3(h)mm

(2) Viewing Area ----- 67.5(w)*35.3(h) mm

(3) Dot Size ----- 0.46(w) * 0.46(h) mm

(4) Dot Quality----- 132 * 64

(5) Outline Dimensions----- See Attached Drawing

3. Front Cover Material Selection:

The following front cover requirements are necessary to insure image quality during the life of the display module:

- (1): bi-stable Liquid Crystal materials require protection from UV light. A UV blocking material with a minimum 98% cut off at 380nm and lower spectral components is required.
- (2) The finished product design should incorporate a transparent cover such as acrylic, polycarbonate, etc., to protect the viewing area of the display. Place the protective cover as close to the display module as possible. The protective cover should be sufficient thickness to resist flexing, or if flexed should not touch the surface of display.
- (3) Adding an anti-glare and or anti-reflective surface film or finish to the viewing side of the protectible cover may improve the optical performance in certain display applications and lighting conditions.

4. Absolute Maximum Ratings

(Voltage Reference to $V_{SS} = 0V$)

Symbol	Parameter	Value	Unit
V_{DD}	Supply Voltage	-0.3 to +3.6	V
V_{DDIO}		-0.3 to $\text{Min}(V_{DD} + 0.5, +3.6)$	V
V_0		-0.3 to 38	V
V_{CI}		-0.3 to +3.6	V
V_{in}	Input Voltage	$V_{SS} - 0.3$ to $V_{DDIO} + 0.3$	V

Maximum Ratings are those beyond which damage to the device may occur. Functional operation should be restricted to the limits in the Electrical Characteristics tables or Pin Description.

design • manufacture • supply

5.Pin Connections:

Pin No.	Symbol	Function
1	V0	It is the high voltage power input pin and panel driving voltage
2-5	V4-V1	Panel driving voltage
6-8	PS0,PS1,PS2	These pins are for selecting different bus interface
9	D/C#	This pin is Data/Command control pin
10	E(RD#)	This pin is MCU interface input
11	R/W #	This pin is MCU interface input
12	CS1#	These pins are the chip select inputs for communication between MCU.
13	RES#	This pin is the reset signal input
14-21	D0-D7	Data bus
22	BUSY	A high level indicates busy status of the driver.
23	VDD	Power supply
24	VSS	Ground
25	VCP1	Charge pump output voltage
26-27	C1P, C1N	Charge pump flying capacitor terminal
28	VCP2	Charge pump intermediate output voltage
29-30	C2P, C2N	Charge pump flying capacitor terminal
31	VCP3	Charge pump intermediate output voltage
32-33	C3P,C3N	Charge pump flying capacitor terminal
34	VCP4	Charge pump intermediate output voltage
35-36	C4P, C4N	Charge pump flying capacitor terminal

6. Timing Characteristics:

Conditions:

$T_A = -35$ to 85°C

$V_{DD} = V_{CI} = V_{DDIO} = 2.4\text{V}$ to 3.5V

Parallel 6800-series Interface Timing Characteristics

Symbol	Parameter	Min	Typ	Max	Unit
t_{cycle}	Clock Cycle Time	100	-	-	ns
t_{AS}	Address Setup Time	0	-	-	ns
t_{AH}	Address Hold Time	20	-	-	ns
t_{DSW}	Write Data Setup Time	30	-	-	ns </td
t_{DHW}	Write Data Hold Time	20	-	-	ns
t_{DHR}	Read Data Hold Time	10	-	50	ns
t_{OH}	Output Disable Time	-	-	40	ns
t_{ACC}	Access Time (RAM)	15	-	-	ns
	Access Time (Command)	15	-	-	ns
PW_{CSL}	Chip Select Low Pulse Width (read RAM)	250	-	-	ns
	Chip Select Low Pulse Width (read Command)	250	-	-	ns
	Chip Select Low Pulse Width (write)	50	-	-	ns
PW_{CSH}	Chip Select High Pulse Width (read)	100	-	-	ns
	Chip Select High Pulse Width (write)	50	-	-	ns
t_{R}	Rise Time	-	-	10	ns
t_{F}	Fall Time	-	-	10	ns

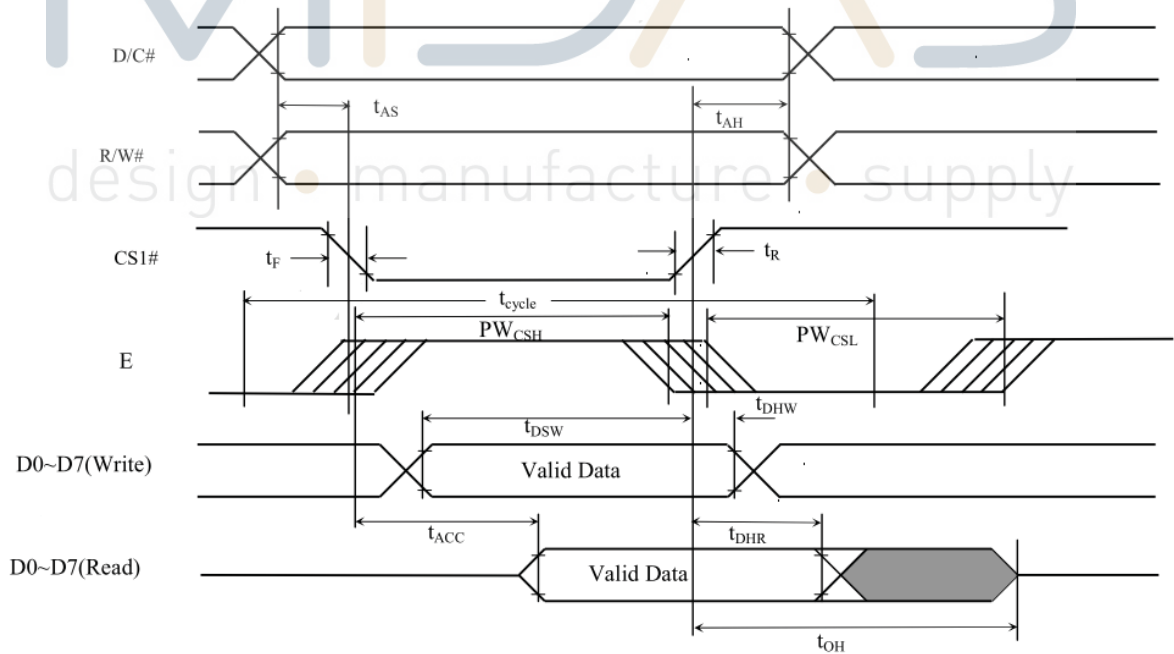

The PW_{CSH} timing reference is 50% of the rising / falling edge of E or CS1# pin.

The t_{DSW} and t_{DHW} timing is reference to the 50% of rising / falling edge of E or CS1# pin.

Conditions:

$T_A = -35$ to 85°C

$V_{DD} = V_{CI} = V_{DDIO} = 2.4\text{V}$ to 3.5V

Parallel 8080-series Interface Timing Characteristics

Symbol	Parameter	Min	Typ	Max	Unit
t_{cycle}	Clock Cycle Time	100	-	-	ns
t_{AS}	Address Setup Time	0	-	-	ns
t_{AH}	Address Hold Time	20	-	-	ns
t_{DSW}	Write Data Setup Time	30	-	-	ns
t_{DHW}	Write Data Hold Time	20	-	-	ns
t_{DHR}	Read Data Hold Time	10	-	50	ns
t_{OH}	Output Disable Time	-	-	40	ns
t_{ACC}	Access Time (RAM)	15	-	-	ns
	Access Time (Command)	15	-	-	ns
PW_{CSL}	Chip Select Low Pulse Width (read RAM)	250	-	-	ns
	Chip Select Low Pulse Width (read Command)	250	-	-	ns
	Chip Select Low Pulse Width (write)	50	-	-	ns
PW_{CSH}	Chip Select High Pulse Width (read)	100	-	-	ns
	Chip Select High Pulse Width (write)	50	-	-	ns
t_{R}	Rise Time	-	-	10	ns
t_{F}	Fall Time	-	-	10	ns

Write Cycle

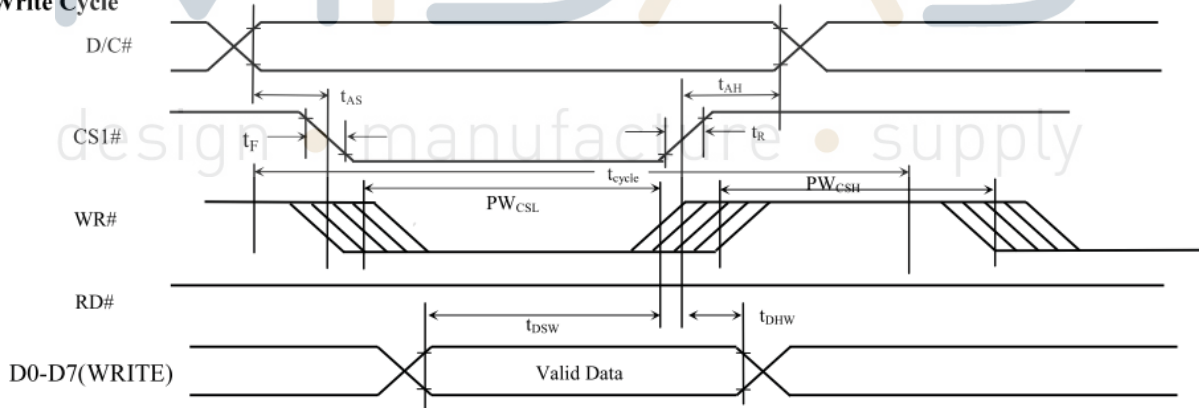

The PW_{CSL} timing reference is 50% of the rising / falling edge of WR# or CS1# pin.

The t_{DSW} and t_{DHW} timing is reference to the 50% of rising / falling edge of WR# or CS1# pin.

Read Cycle

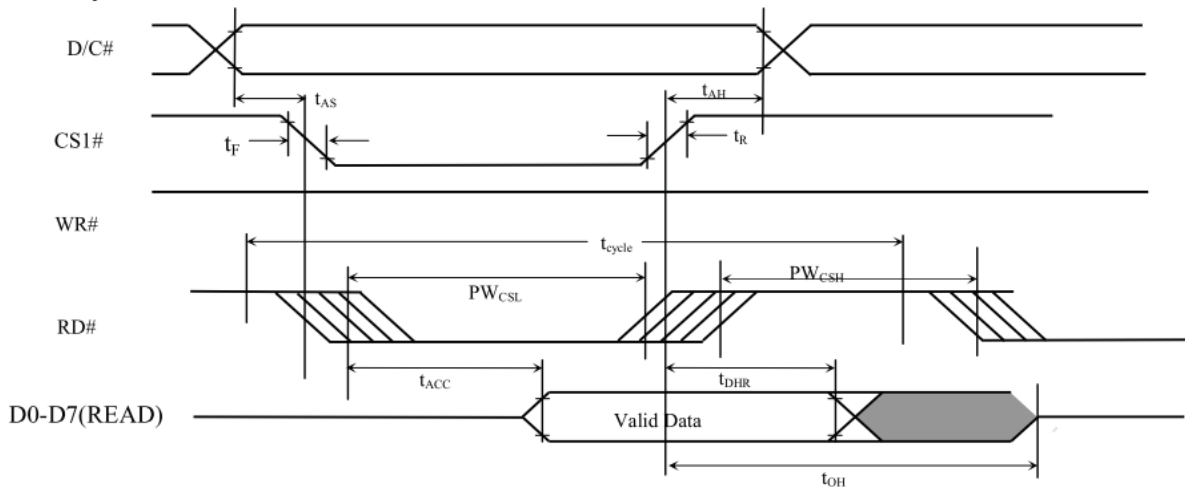

The PW_{CSL} timing reference is 50% of the rising / falling edge of RD# or CS1# pin.
 The t_{DSW} and t_{DHW} timing is reference to the 50% of rising / falling edge of RD# or CS1# pin.

Conditions:

$T_A = -35$ to 85°C

$V_{DD} = V_{CI} = V_{DDIO} = 2.4\text{V to }3.5\text{V}$

4-wires Serial Interface Timing Characteristics

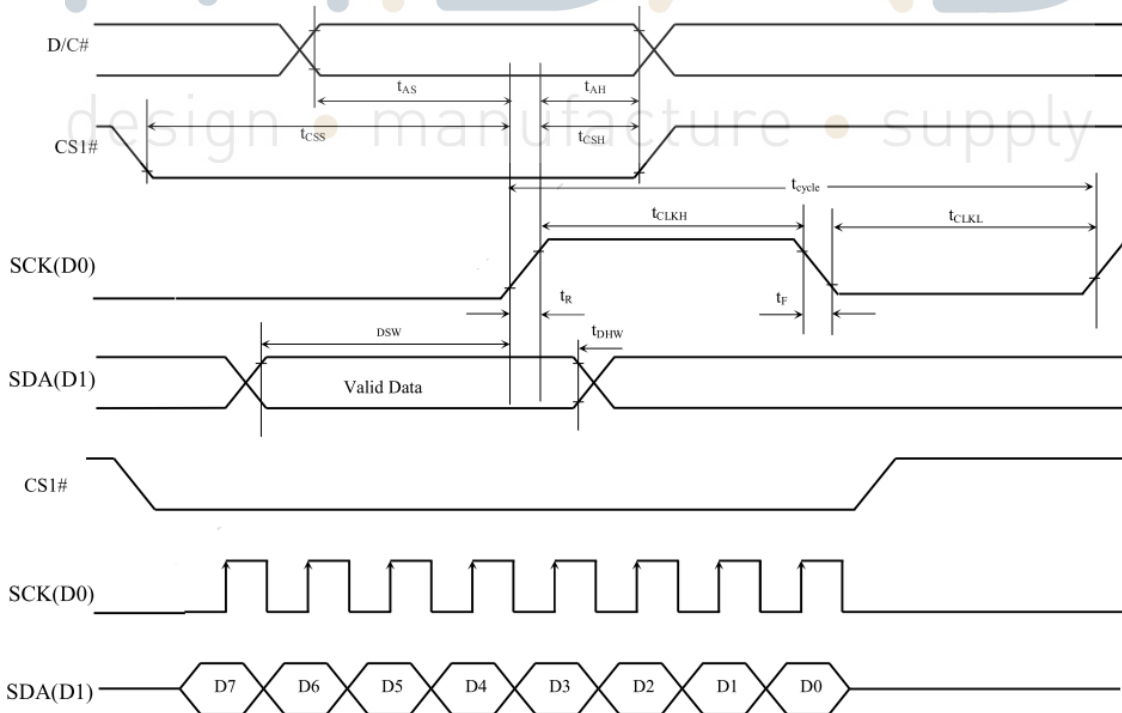

Conditions:

$T_A = -35$ to 85°C

$V_{DD} = V_{CI} = V_{DDIO} = 2.4\text{V}$ to 3.5V

3-wire Serial Interface Timing Characteristics

Symbol	Parameter	Min	Typ	Max	Unit
t_{cycle}	Clock Cycle Time	80	-	-	ns
t_{AS}	Address Setup Time	20	-	-	ns
t_{AH}	Address Hold Time	20	-	-	ns
t_{CSS}	Chip Select Setup Time	30	-	-	ns
t_{CSH}	Chip Select Hold Time	20	-	-	ns
t_{DSW}	Write Data Setup Time	20	-	-	ns
t_{DHW}	Write Data Hold Time	20	-	-	ns
t_{CLKL}	Clock Low Time	40	-	-	ns
t_{CLKH}	Clock High Time	40	-	-	ns
t_{R}	Rise Time	-	-	10	ns
t_{F}	Fall Time	-	-	10	ns

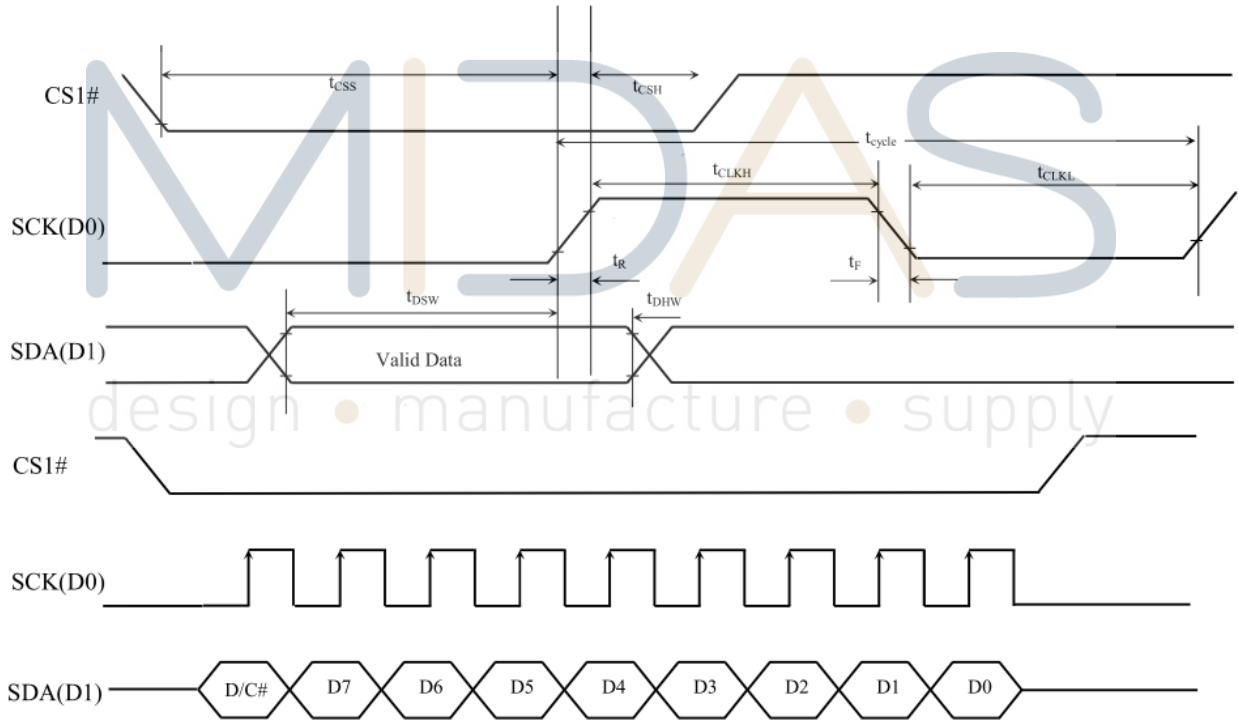

Conditions: $T_A = -35$ to 85°C $V_{DD} = V_{CI} = V_{DDIO} = 2.4\text{V}$ to 3.5V **4-wires Serial Interface Timing Characteristics**

Symbol	Parameter	Min	Typ	Max	Unit
t_{cycle}	Clock Cycle Time	2.5	-	-	us
t_{HSTART}	Start condition Hold Time	0.6	-	-	us
t_{SD}	Data Setup Time	100	-	-	ns
t_{SSTART}	Start condition Setup Time (Only relevant for a repeated Start condition)	0.6	-	-	us
t_{SSTOP}	Stop condition Setup Time	0.6	-	-	us
t_{R}	Rise Time for data and clock pin	-	-	300	ns
t_{IDLE}	Idle Time before a new transmission can start	1.3	-	-	us

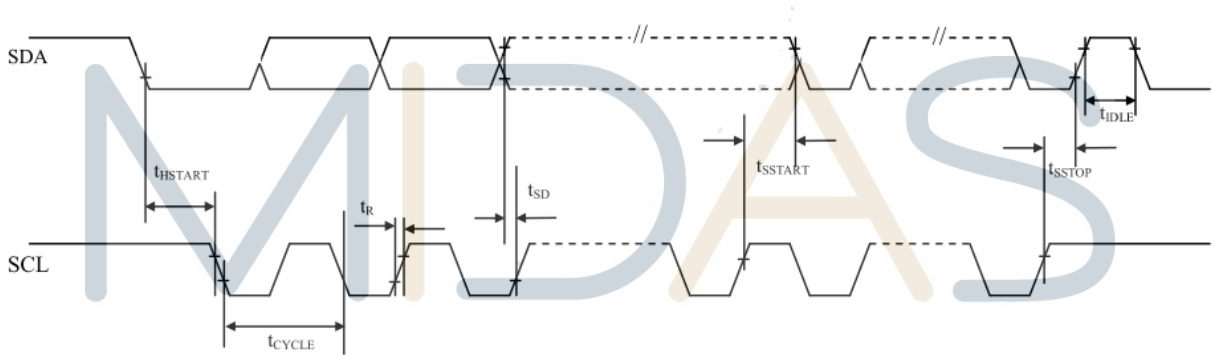

design • manufacture • supply

7.Charge Pump Application Circuit

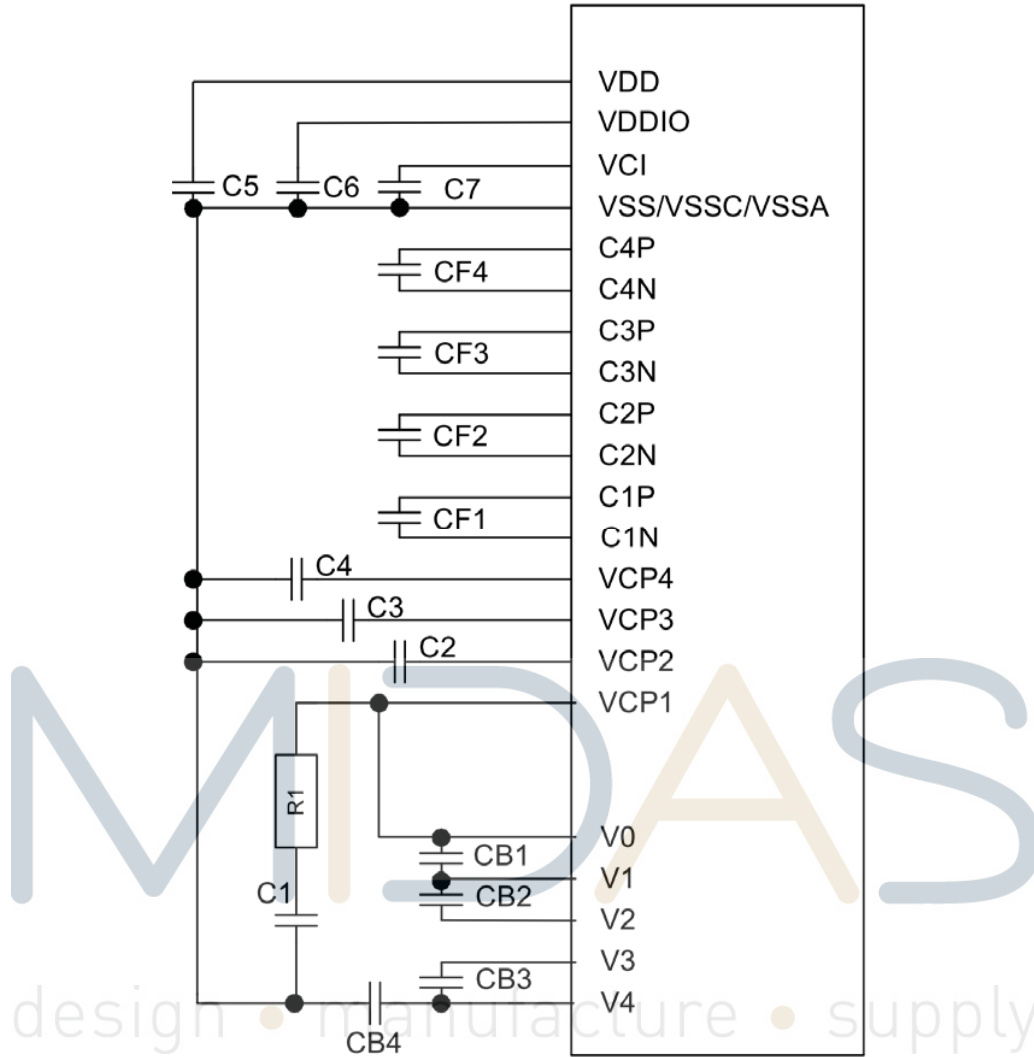

Reference Capacitor Value

Part reference	Value (uF)	Min Rating
CF1	1.0	50V
CF2	1.0	25V
CF3	1.0	25V
CF4	1.0	10V
C1	4.7	50V
C2	0.1	25V
C3	0.1	10V
C4	0.1	10V
C5	1.0	10V
C6	1.0	10V
C7	1.0	10V
CB1	1.0	10V
CB2	1.0	10V
CB3	1.0	10V
CB4	1.0	10V
Part reference	Value (Ohm)	Remark
R1	0	For Typical case

Capacitor values requirement depends on panel loading and voltage setting.

II. The Characteristics and The Reliability Test

1. Electro-Optic Characteristics:

Condition: TEMP=(23±3)°C Hum=(70±5)%RH

NO	Item	Symbol	Min	Typ.	Max	Unit	Condition
1	Supply Voltage(Logic)	Vdd-Vss		3.0		V	
2	LCD Operating Voltage	Vdd-V ₀		30.2		V	0°C
			29.8	30.0	30.2		25°C
				29.8			50°C
3	Image refresh time	-		8.0		s	25°C
4	Contrast Ratio	CR		6			
5	Viewing Angle	12H	θ 1		80	Deg	(CR≥2.0)
		6H	θ 2		80		
		3H	θ 3		80		
		9H	θ 4		80		
6	Sleep mode current	Islp		1		μ A	

MIDAS

design • manufacture • supply

2. Reliability Test

No	Items	Test Condition	Equipment	Test Result
1	High TEMP Storage	TEMP: $70 \pm 2^{\circ}\text{C}$ Time: 96h Restore: 24h	Tenny	Passed
2	Low TEMP Storage	TEMP: $-20 \pm 3^{\circ}\text{C}$ Time: 96h Restore: 24h	Tenny	Passed
3	High TEMP Operating	TEMP: $50 \pm 2^{\circ}\text{C}$ Vop: 3.0V Time: 24h Restore: 24h	Tenny	Passed
4	Low TEMP Operating	TEMP: $0 \pm 2^{\circ}\text{C}$ Vop: 3.0V Time: 24h Restore: 24h	Tenny	Passed
5	High TEMP High Hum Storage	TEMP: $40 \pm 2^{\circ}\text{C}$ Hum: 95%Rh Time: 96h Restore: 24h	Tenny	Passed
6	Thermal Shock	<p>TEMP: ($^{\circ}\text{C}$)</p> <p>The diagram shows a thermal shock profile with 5 cycles. The temperature starts at 25°C, drops to -20°C, dwells for 30 minutes, rises to 70°C, dwells for 5 minutes, drops to 25°C, dwells for 30 minutes, and rises to 70°C. This sequence repeats for 5 cycles. The total duration is labeled as 5 Cycles and Restore: 24h.</p> <p>70°C 25°C -20°C</p> <p>30 5 30 5 Min</p> <p>5 Cycles Restore: 24h</p>	Tenny	Passed

III. The LCD Measuring Method and Equipment

1. Threshold Voltage and Response Time Measuring

(1) Equipment

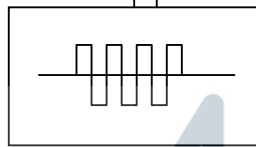
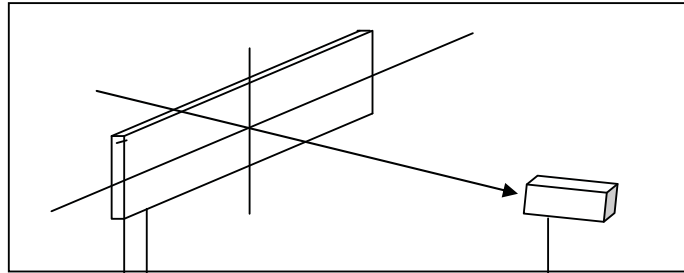

Oscilloscope

Waveform Generator

(2) Definition

A. Threshold Voltage (V_{th})

Brightness

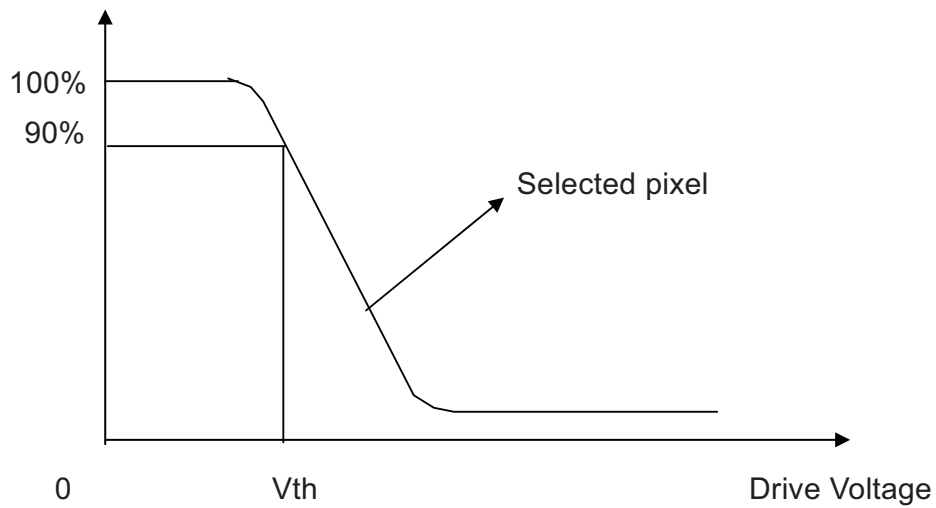

B. Response Time

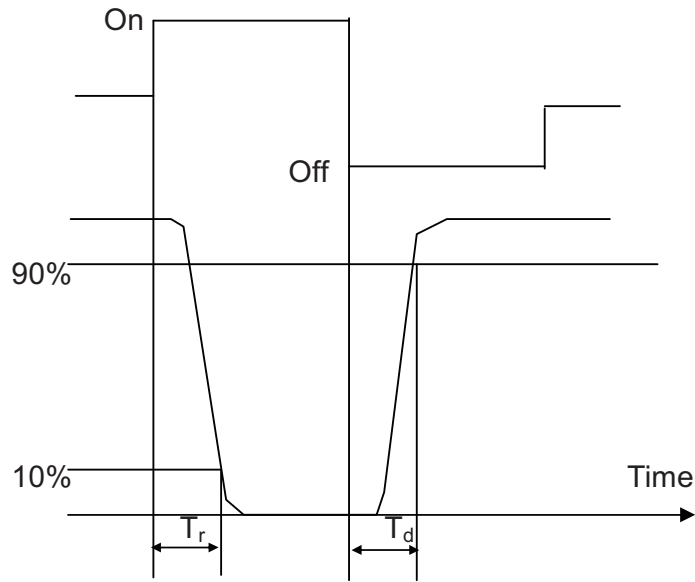

2. Contrast Measuring (1) Equipment

MIDAS

design • manufacture • supply

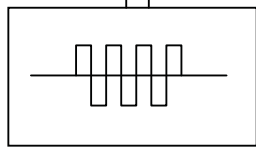
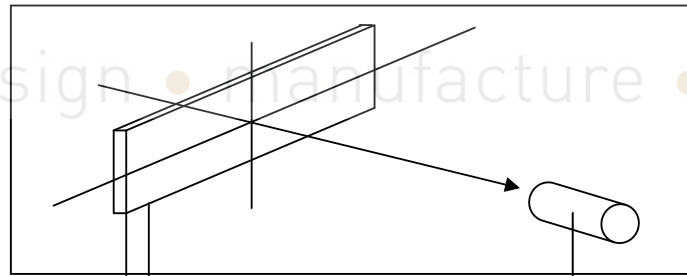

Waveform Generator

Spectrophotometer

(2) Definition:

A. Viewing Angle:

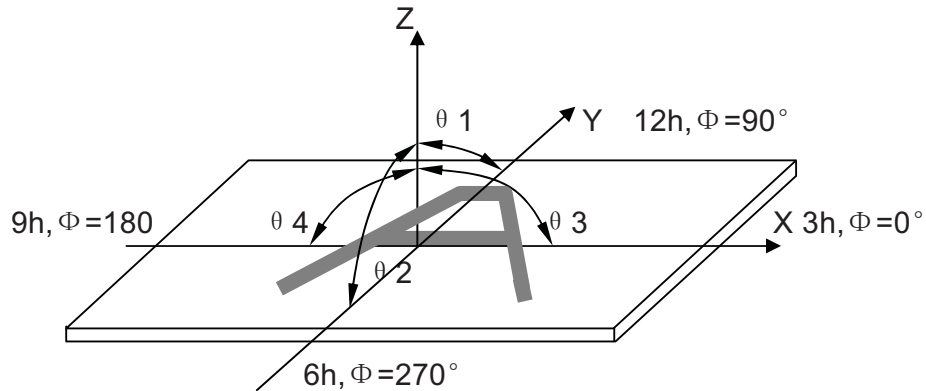

B. Contrast Ratio (Positive)

$$CR = \frac{\text{Brightness of non-selected pixel}}{\text{Brightness of selected pixel}}$$

3. Reliability Test: • design • manufacture • supply
Equipment : TENNY

IV. Standard Specifications for Product Quality

1. MTBF

More than 50,000 hours.

2. Method of Test:

(1) The Test Must Be Under 40W Fluorescent Lamp, And The Distance Of View Must Be At 30cm.

(2) The eye's Test Direction Is Based On the vertical direction 15° - 45° .

3. Definition Of Defects

(1) Major Defects

A: Non-Display

B: Segment Missing

C: Over Current

D: Segment Short

E: Wrong Polarizer Direction

(2) Minor Defects: The Others.

4. Major Defects Should Be In AQL 0.25, and The Minor In AQL 1.00

The sampling inspection plan is in accordance with the Level II and normal inspection.

Definition of area:

I area: viewing area

II area: Outside of viewing area

A area: The area outside sealing

G area : Electrode pad area

F area : Without electrode pad area

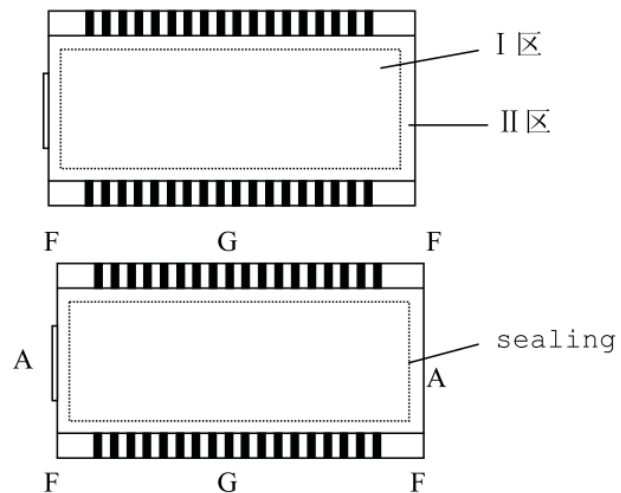

5. Inspection Item and Standards

Item	The Standard Of Quality Inspection	Checking Method	Quantity Ratio
Frame	Smooth and even surface, no crack, no scratch, no rusty, and not be wrenched out of shape. the range between convex and concave is: $d \leq 0.35\text{mm}$, and the frame must be connected with the ground pad.	Checking With Eyes And Using Vernier Caliper, Multimeter	100%
The Relative Position of LCD and Frame	The end seal of the LCD must be at the same side with the frame's opening.	Checking With Eyes	100%
The Relative Position of PCB/Panel /Frame	The frame installing direction must be correct. the twisted angle of the leg is from 45° to 60° , the leg is vertical to PCB panel and it must be in the middle position of the installing holes.	Checking With Eyes	100%
Function Test	<ol style="list-style-type: none"> 1. The major defects must be reject. 2. Background changes evenly and no disorderly displaying phenomenon. 3. Display no shortage. 	Check It When Displaying	100%

LCD:

Standard of appearance test: (unit: mm)

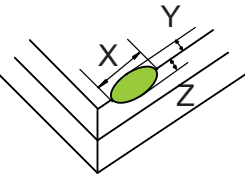
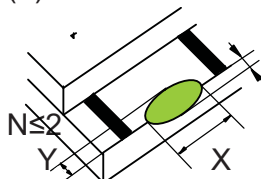
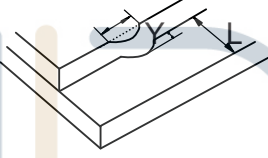
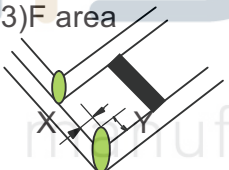
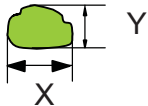
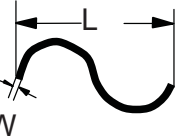
№	Items	Criterion	Checking manner
1	<p>Substrate crack</p> <p>X: defect Length</p> <p>Y: defect Width</p> <p>Z: defect Depth</p> <p>T: glass Thickness</p> <p>N: defect QTY</p> <p>L: Connector Width</p>	<p>(1) A area</p>  <p>$X \leq 3.0$ Y: Don't allowed hurt sealing $Z \geq T/2$ $N \leq 3$ $X \leq 5.0$ Y: Don't allowed hurt sealing $Z \leq T/2$ $N \leq 3$ $X \leq 1.0$ $Y \leq 0.5$ $Z \leq T/3$ No check</p> <p>(2) G area</p>  <p>Z $X \leq 3.0$ $Y \leq 0.5$ $Z \leq T/2$ $N \leq 2$</p>  <p>$X \leq 1/2$ total length $Y \leq 1/4L$ $N \leq 1$ Over the drawing tolerance is not allowed</p> <p>(3) F area</p>  <p>$X \leq 2.0$ $Y \leq 3$ $Z \leq T$ $N \leq 3$ Don't allowed hurt sealing</p>	<p>checking with eyes</p>
2	<p>Black spot white spot $D = (X+Y)/2$</p> <p>Line</p>	<p>(1)</p>  <p>$0.2 < D \leq 0.25$ $N \leq 1$ $0.1 < D \leq 0.2$ $N \leq 3$ $D \leq 0.1$ No check II area No check</p> <p>(2)</p>  <p>$L \leq 2.0$ $W \leq 0.03$ $N \leq 2$ $L \leq 1.0$ $W \leq 0.05$ $N \leq 1$ II area No check</p>	<p>Checking on the table with light and polarizer and checking with eyes directly.</p>

No	Items	Criterion	Checking manner
3	Polarizer Bubble	$D \leq 0.15$ No check $0.15 < D \leq 0.4$ $N \leq 2$ II area No check	Checking on the table with light and polarizer, and checking with eyes directly
4	Rainbow Color	Allow tiny rainbow Allow 5% color contrast or accord limitative sample	Checking on the table with light and polarizer, And checking with eyes directly
5	Polarizer or pad appearance	No dirty	Checking with eyes

Standard of display test

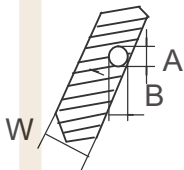
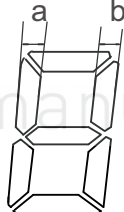
No	Items	Criterion	Checking manner
1	Pin hole $D = (A+B)/2$ W: segment width	 $W \leq 0.4$ $D \leq 0.20$ And $D \leq 1/2W$ $N \leq 1$ $W > 0.4$ $D \leq 0.25$ And $D \leq 1/3W$ $N \leq 2$ $D \leq 0.05$ No check	Checking at the display state
2	Different width of segment	 $ a-b < 0.25$ or $ a-b \leq 1/4W$ No check	Checking at the display state

Note: d ~ Diameter n ~ Quantity Unit: mm

V.Attached Drawing

Customer :

Customer NO. :

Customer Approve By :

REV. A0

DESCRIPTION OF MODIFY I' ST, DESIGN

MODIFY BY :

DATE

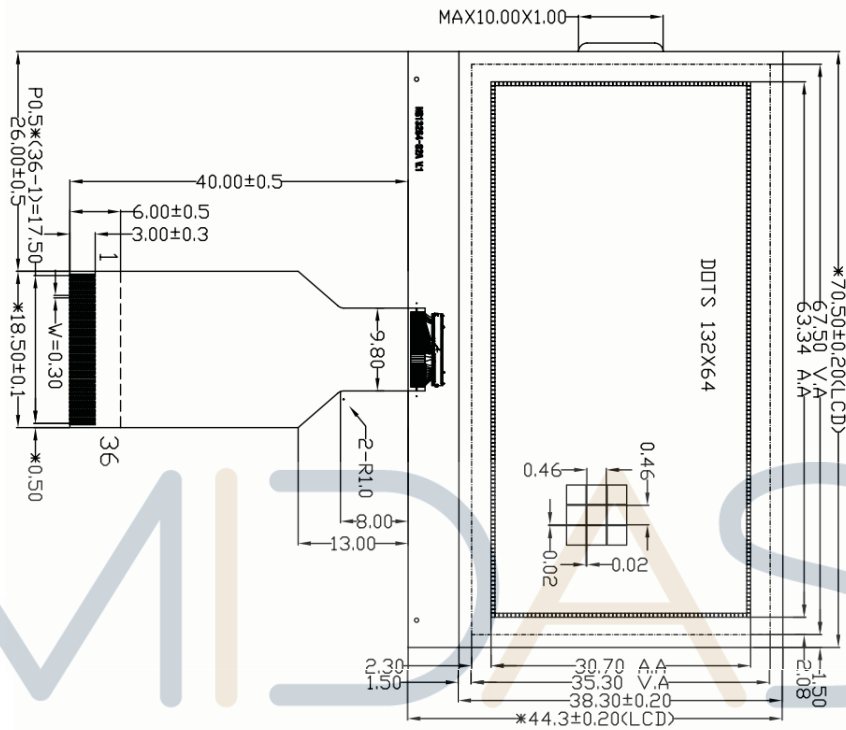

NO	PIN	NO	PIN
1	V0	19	D5
2	V4	20	D6
3	V3	21	D7
4	V2	22	BUSY
5	V1	23	VDD
6	PS0	24	VSS
7	PS1	25	VCP1
8	PS2	26	CIP
9	D/C#	27	CIN
10	E(RD#)	28	VCP2
11	R/W#	29	C2P
12	CS1#	30	C2N
13	RES#	31	VCP3
14	D0	32	C3P
15	D1	33	C3N
16	D2	34	VCP4
17	D3	35	C4P
18	D4	36	C4N

1	Operating Voltage:	3.0V	VLCD: 3.0V
2	Drive method:	Bi-stable driving 1/6duty, 1/30ms	
3	Viewing Direction:	ALL VIEWING ANGLE	
4	Operating Temp:	-20~70°C	
5	Storage Temp:	-30~70°C	
6	Display Area:	Position	
7	Useful field tolerance:	±0.2	
8	LCD controller/driver:		
9	Backlight:		
10	Customer No.:		
11	Dimensions with mark * are important		
12	RoHS compliant		

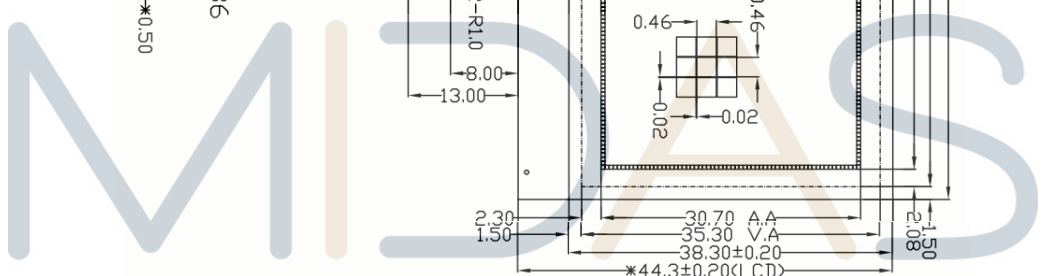

LCM NO. : T 000U0FH0E1 I CE1DWG NO.	UNIT: MM	SIZE: A4
ME BY :	SHEET: 1 OF 1	REV: A0
EE BY :	APPROVED BY :	

VI. Packing

PACKING ORDER:

1) Putting 16 pcs Modules on each EPE tray.

2) Putting 8 pcs EPE trays together with EPE paper on the top of EPE tray.

3) Assembling the boards and the tray together with adhesive tape

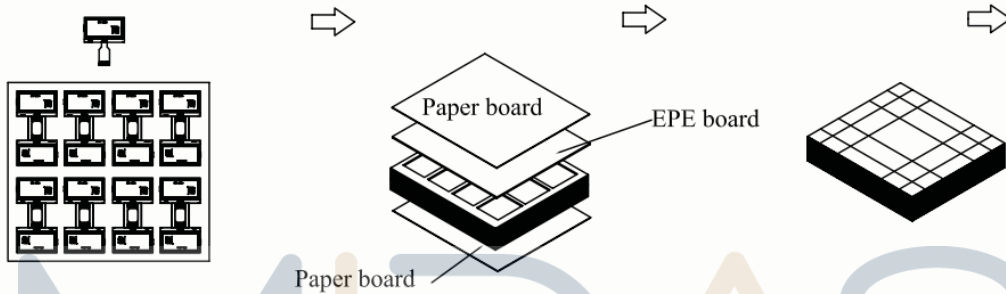

4) Putting in the inner small carton (TYPE:H82)

5) Putting 5 small cartons into one outcarton

6) Packing finished

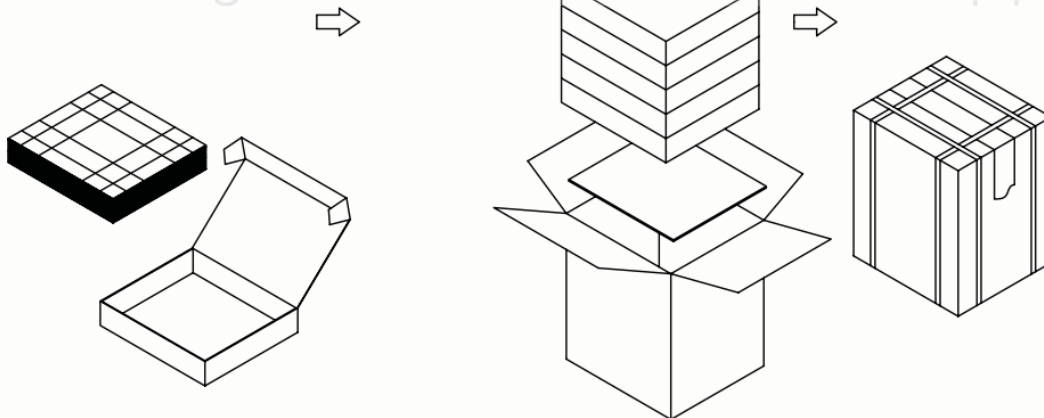

Note: 16 pcs in a tray, 8 trays in a inner carton, 5 inner cartons in a out carton, so $16 \times 8 \times 5 = 640$ pcs/Outcarton

Dimension (Small carton): 385*325*87mm

Dimension (Out carton): 394*344*470mm

VII. Precautions For Use

1. Safety

- (1) Do not swallow any liquid crystal, even if there is no proof that liquid crystal is poisonous.
- (2) If the LCD panel breaks, be careful not to get liquid crystal to touch your skin.
- (3) If skin is exposed to liquid crystal, wash the area thoroughly with alcohol or soap.

2. Storage Conditions

- (1) Store the panel or module in a dark place where the temperature is $23\pm 5^{\circ}\text{C}$ and the humidity is below $50\pm 20\% \text{RH}$.
- (2) Store in anti-static electricity container.
- (3) Store in clean environment, free from dust, active gas, and solvent.
- (4) Do not place the module near organics solvents or corrosive gases.
- (5) Do not crush, shake, or jolt the module.
- (6) Do not exposed to direct sun light of fluorescent lamps.

3. Installing LCD Module

Attend to the following items when installing the LCM.

- (1) Cover the surface with a transparent protective plate or touch panel to protect the polarizer and LC cell.
- (2) When assembling the LCM into other equipment, the spacer to the bit between the LCM and the fitting plate should have enough height to avoid causing stress to the module surface, refer to the individual specifications for measurements.

4. Precautions For Operation

- (1) Viewing angle varies with the change of liquid crystal driving voltage (V_0). Adjust V_0 to show the best contrast.
- (2) Driving the LCD in the voltage above the limit will shorten its lifetime.
- (3) Response time is greatly delayed at temperature below the operating temperature range. However, this does not mean the LCD will be out of the order. It will recover when it returns to the specified temperature range.
- (4) When turning the power on, input each signal after the positive/negative voltage

becomes stable.

(5) Do not apply water or any liquid on product which composed of T/P.

5.Handling Precautions

(1) Avoid static electricity which can damage the CMOS LSI; please wear the wrist strap when handling.

(2) The polarizing plate of the display is very fragile. Handle it very carefully.

(3) Do not give external shock.

(4) Do not apply excessive force on the surface; it may cause display abnormal .

(5) Do not wipe the polarizing plate with a dry cloth, as it may easily scratch the surface of plate.

(6) Do not use ketonics solvent & Aromatic solvent, use with a soft cloth soaked with a cleaning naphtha solvent.

(7) Do not operate it above the absolute maximum rating.

(8) Do not remove the panel or frame from the module.

(9) Do not apply water or any liquid on product which composed of T/P.

MIDAS

design • manufacture • supply