

## Main applications

- Extruders and injection moulding machines for the plastics industry
- Polymerisation and synthetic fibre production plants
- Rubber vulcanisation plants
- Climatic chambers and test benches
- Furnaces for ceramics and bricks
- Chemical and pharmaceutical industries
- Ovens
- Food processing plants
- Painting cabinets
- Water treatment
- Siderurgy industry



## Main features

- Universal input configurable from the faceplate
- Acquisition of the input signal every 120msec ; resolution 30000steps
- Two control outputs: relay, logic or analogue with Heat/Cool function
- 3 configurable alarms
- 2 analogue outputs (setpoint retransmission)
- 2 digital inputs with configurable function
- Auxiliary input for C.T. or remote setpoint
- Heater Break or shortcircuit probe alarm
- Self and Auto-tuning, Soft-start, Local/Remote setpoint, Auto/Man
- Function multiset, rampa di set, timer

## GENERAL

Microprocessor controller, format 48x96 / 96x96 (1/8 DIN - 1/4 DIN) manufactured using SMT.

The instrument provides a complete operator interface, protected by a Lexan membrane that ensures level IP65 faceplate protection.

It has 4 keys, two green LED displays, each with 4 digits, 4 red indicating LED's for the 4 logic or relay outputs, and a further 3 LED's that are programmable to indicate the various operational states of the instrument.

The main input for the process variable is universal and provides the possibility to connect many types of input sensor: thermocouple type J, K, R, S, T, B, E, N, Ni-Ni18Mo, L; resistance thermometer Pt100 3-wires; thermistor PTC; linear inputs 0-50mV, 10-50mV, 2-10V, 0-10V, 0-20mA, 4-20mA, and potentiometer, all with the possibility of custom linearisation that can be defined using the faceplate keys.

The type of input is selected from the faceplate keys and no external shunts or adapter are required.

A second auxiliary isolated analogue input is available, which can also be configured for a linear input (0-10V, 2-10V, 0-20mA / 4-20mA), for remote setpoint, potentiometer or current transformer.

The auxiliary input function is completely configurable, including the possibility of a custom linearization.

It is possible to configure the 2 available isolated digital inputs for selection of up to 4 local setpoints; start, stop and reset of internal timer; Auto/Man, Loc/Rem functions; alarms memory reset; input hold function.

The instrument can have up to 4 relay (3A/250V) or logic (12Vdc, 20mA) outputs and up to 2 isolated analogue outputs in voltage or current.

The function of each output is completely configurable by faceplate.

The available functions include: control output, alarm output, timer, digital input repetition, retransmission of process value, setpoints, deviation, alarm setpoint or value read from digital communication. A further isolated output (10 or 24Vdc, 30mA max.) is available for powering external transmitters or potentiometers. The optional serial communications can be Current Loop, RS232 or RS485, while the protocol can be selected between Gefran (Cencal) and Modbus.

Using these it is possible to write to any of the instrument parameters.

All the programming procedures of the instrument are facilitated by the grouping of the parameters in function blocks (CFG

for the control parameters, **Inp** for the inputs, **Out** for the outputs, etc.) and by the possibility of selecting a simplified menu for entering the most frequently used parameters.

To simplify the configuration even further, a programming kit is available for PC, which includes a menu driven configuration program for Windows and the necessary cable to connect the instrument (see data sheet cod. 80021).

## TECHNICAL DATA

### INPUTS

Accuracy 0,2% f.s.  $\pm 1$ digit.

Acquisition of the input signal 120msec.

### TC - Thermocouples

**J** (Fe-CuNi) 0...1000°C / 32...1832°F

**K** (NiCr-Ni) 0...1300°C / 32...2372°F

**R** (Pt13Rh-Pt) 0...1750°C / 32...3182°F

**S** (Pt10Rh-Pt) 0...1750°C / 32...3182°F

**T** (Cu-CuNi) -200...400°C / -328...752°F

**B** (Pt30Rh-Pt6Rh) 44...1800°C / 111...3272°F

**E** (NiCr-CuNi) -100...750°C / -148...1382°F

**N** (NiCrSi-NiSi) 0...1300°C / 32...2372°F

**(Ni-Ni18Mo)** 0...1100°C / 32...2012°F

**L-GOST** (NiCr-CuNi) 0...600°C / 32...1112°F

### RTD 3-wires

Pt100 -200...600°C / -328...1112°F

JPt100 (JIS C 1609/81)

-200...600°C / -328...1112°F

### PTC

(alternative to RTD)

-55...120°C / -67...248°F

### DC - Linear

0...50mV

10...50mV

0...20mA

4...20mA

0...10V

2...10V

Custom linearisation with 32 segment

### Auxiliary input

insulation 1500V

For remote setpoint:

(0...10V, 2...10V,  $R_i=1M\Omega$ )

(0...20mA, 4...20mA,  $R_i=5\Omega$ )

potentiometer > 500 $\Omega$

For current transformer:

CT 50mAac, 50/60Hz,  $R_i=1,5\Omega$

### Logic

Insulation 1500V

NPN 24V/4,5mA (PNP 24V/3,6mA)

Configurable function: Man/Auto,

Loc/Rem, Alarms Reset, Hold,

Setpoint selection.

### OUTPUTS

Outputs fully configurable for: single alarm, "OR" or "AND" of multiple alarms, logic input repetition.

### Relay

With rating: 5A/250V,  $\cos\varphi=1$

(order code R)

### Logic

11Vdc,  $R_{out}=220\Omega$ .=(20mA, max.6V)

(order code D)

### Retransmission

isolated 1500V

- Up to 2 analogue outputs for control or retransmission (input signal, setpoint, auxiliary input, alarm setpoint).

- Scale range selectable from keyboard.

- Configurable output 0...10Vdc;

0...20/4...20mA

- Resolution 4000 steps

### SERIAL LINE

Optoisolated 4-wires

Passive Current Loop configurable (1200 baud) interface, RS232 and RS422/485 (1200, 2400, 4800, 9600 baud).

Protocol: GEFTRAN CENCAL or MODBUS

### POWER SUPPLY

Standard: 100 to 240Vac/dc  $\pm 10\%$

on request: 20 to 27Vac/dc  $\pm 10\%$

50/60Hz; 12VAmax.

Protection by internal fuse not serviceable by the user

### Transmitter Supply

isolatedxd 1500V

10/24Vdc max. 30mA short circuit protection

### AMBIENT CONDITION

Working temperature range: 0...50°C

Storage temperature range: -20...70°C

Humidity: 20...85%Ur non condensing

### Control

Cooling setpoint relative to Heating setpoint

On/Off, P, PD, PID for heating and cooling with configurable parameters.

• Proportional band 0,0...999,9% f.s.

• Integral time 0,0...999,9 min

• Derivative time 0,0...99,99 min

• Max control output power limitation:

0,0...100,0%

• Manual Reset -999...999 digit

• Power Reset -100,0...100,0%

• Cycle time 0...200sec

• Soft-start 0,0...500,0 min

### Alarms

- Up to 3 alarms, settable as absolute, deviation or symmetrical deviation alarm with respect to the control setpoint with configurable function (Hi or Lo).

- The alarm point may be set anywhere within the configured scale.

- Heater Break Alarm

- Loop Break Alarm

- Alarm Hysteresis configurable

- Alarms can be assigned to main input, auxiliary input or control SP.

### WEIGHT

400g (1600); 600g (1800) in complete version

## FACEPLATE DESCRIPTION

A - PV Display: process variable

B - SV Display: setpoint value

C - "Function" key

D - "Lower" key

E - "Raise" key

F - "Automatic/Manual" selection

G - Function indication

H - Indication of active outputs

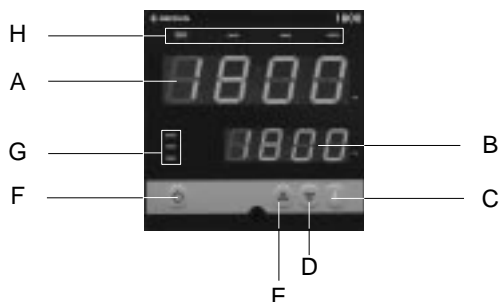
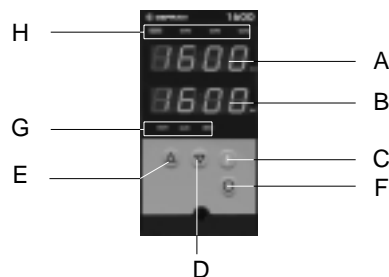

Double green LED display (4 Digit)

Faceplate protection IP65

## DIMENSIONS AND CUT OUT

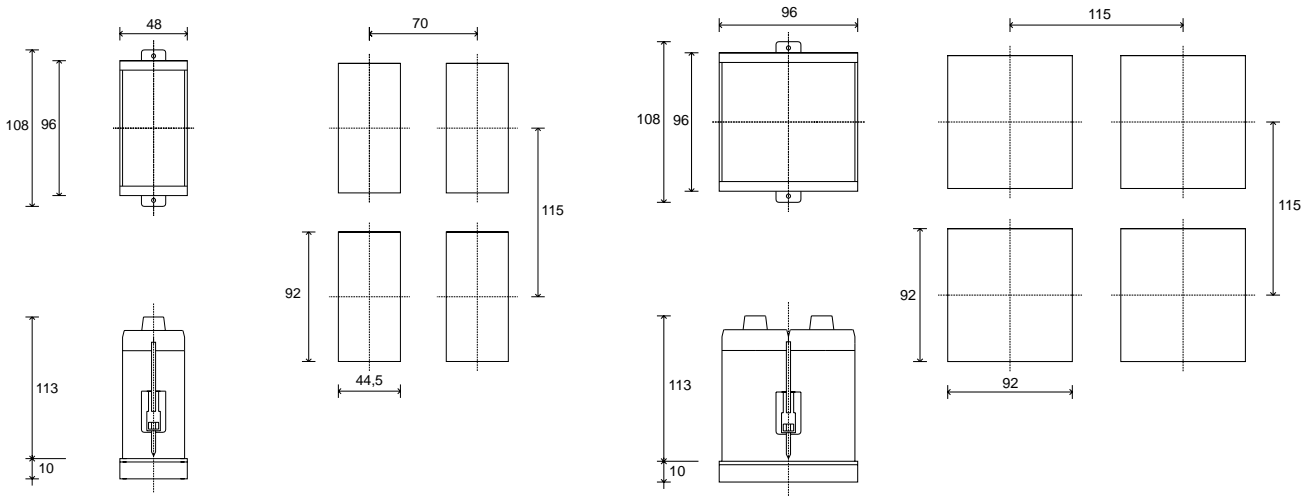

Dimensions: 48x96mm - 96x96mm (1/8DIN - 1/4DIN), depth 113mm

## CONNECTION DIAGRAM

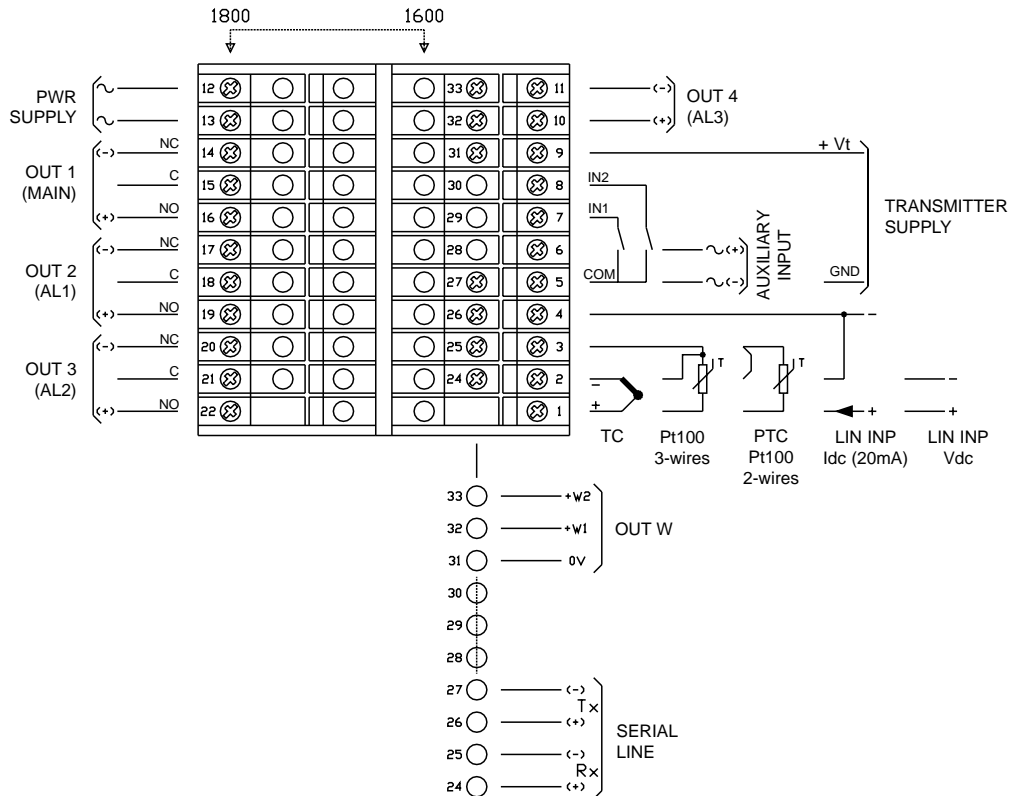

 Apply user's manual warnings for a correct installation

# ORDER CODE

MODEL	
1600	1600
1800	1800

POWER SUPPLY	
0	20...27Vac/dc
1*	100...240Vac/dc

OUTPUT 1,2,3,4 (R/D)	
Out1 (R)	R000
Out1 (R) + Out2 (R)	RR00
Out1 (R) + Out2 (R) + Out3 (R)	RRR0*
Out1 (R) + Out2 (R) + Out3 (R) + Out4 (R)	RRRR
Out1 (D)	D000
Out1 (D) + Out2 (R)	DR00
Out1 (D) + Out2 (R) + Out3 (R)	DRR0
Out1 (D) + Out2 (R) + Out3 (R) + Out4 (R)	DRRR
Out1 (D) + Out2 (D)	DD00
Out1 (D) + Out2 (D) + Out3 (R)	DDR0
Out1 (D) + Out2 (D) + Out3 (R) + Out4 (R)	DDRR
Out1 (D) + Out2 (D) + Out3 (D)	DDD0
Out1 (D) + Out2 (D) + Out3 (D) + Out4 (R)	DDDR
Out1 (D) + Out2 (D) + Out3 (D) + Out4 (D)	DDDD

DIGITAL COMMUNICATION	
0*	None
1	Current Loop
2	RS 485
3	RS 232C

AUXILIARY INPUTS	
00*	None
01	IN1, IN2 NPN
02	IN1, IN2 PNP
03**	Transmitter supply 10V
04**	IN1, IN2 NPN + Transmitter supply 10V
05**	IN1, IN2 PNP + Transmitter supply 10V
06**	IN SPR (0...1V) + Transmitter supply 10V
07**	IN SPR (0...10V) / IN Potentiometer # + Transmitter supply 10V
08**	IN SPR (0/4...20mA) + Transmitter supply 10V
09**	CT (50mAac) + Transmitter supply 10V
10**	IN1, IN2 NPN IN SPR (0...1V) + Transmitter supply 10V
11**	IN1, IN2 NPN IN SPR (0...10V) / IN Potentiometer # + Transmitter supply 10V
12**	IN1, IN2 NPN IN SPR (0/4...20mA) + Transmitter supply 10V
13**	IN1, IN2 PNP CT (50mAac) + Transmitter supply 10V
14**	IN1, IN2 PNP IN SPR (0...1V) + Transmitter supply 10V
15**	IN1, IN2 PNP IN SPR (0...10V) / IN Potentiometer # + Transmitter supply 10V
16**	IN1, IN2 PNP IN SPR (0/4...20mA) + Transmitter supply 10V
17**	IN1, IN2 PNP CT (50mAac) + Transmitter supply 10V
33	IN SPR (0...1V)
34	IN SPR (0...10V)
35	IN SPR (0/4...20mA)
36	CT (50mAac)

OUTPUT 5, 6	
None	00*
OUT 5 (W1) 0...10V	V0
OUT 5 (W1) 0/4...20mA	I0
OUT 5 (W1) 0...10V OUT 6 (W2) 0...10V	VV
OUT 5 (W1) 0/4...20mA OUT 6 (W2) 0...10V	IV
OUT 5 (W1) 0...10V OUT 6 (W2) 0/4...20mA	VI
OUT 5 (W1) 0/4...20mA OUT 6 (W2) 0/4...20mA	II

(\*) Standard version  
 (\*\*) Adding + 15 to obtain 24V transmitter supply  
 # Potentiometer input requires 10V transmitter supply

For PTC input specific calibration must be required

GEFRAN spa reserves the right to make any kind of design or functional modification at any moment without prior notice.

	In conformity to ECC 89/336/CEE and 73/23/CEE with reference to standards: - EN 50082-2 (immunity in industrial environment) - EN 50081-1 (emission in residential environment) - EN 61010-1 (safety)

In a short while it will also conform to the CSA / CSA NRTL marks.



GEFRAN spa via Sebina, 74 - 25050 Provaglio d'Iseo (BS)  
 Tel. 03098881 - fax 0309839063 - Internet: <http://www.gefran.com>



cod. 84291 - 07/00