

Jun.1.2018 Copyright 2018 HIROSE ELECTRIC CO., LTD. All Rights Reserved.  
 In case of consideration for using Automotive equipment /  
 device which demand high reliability, kindly contact our sales window correspondents.

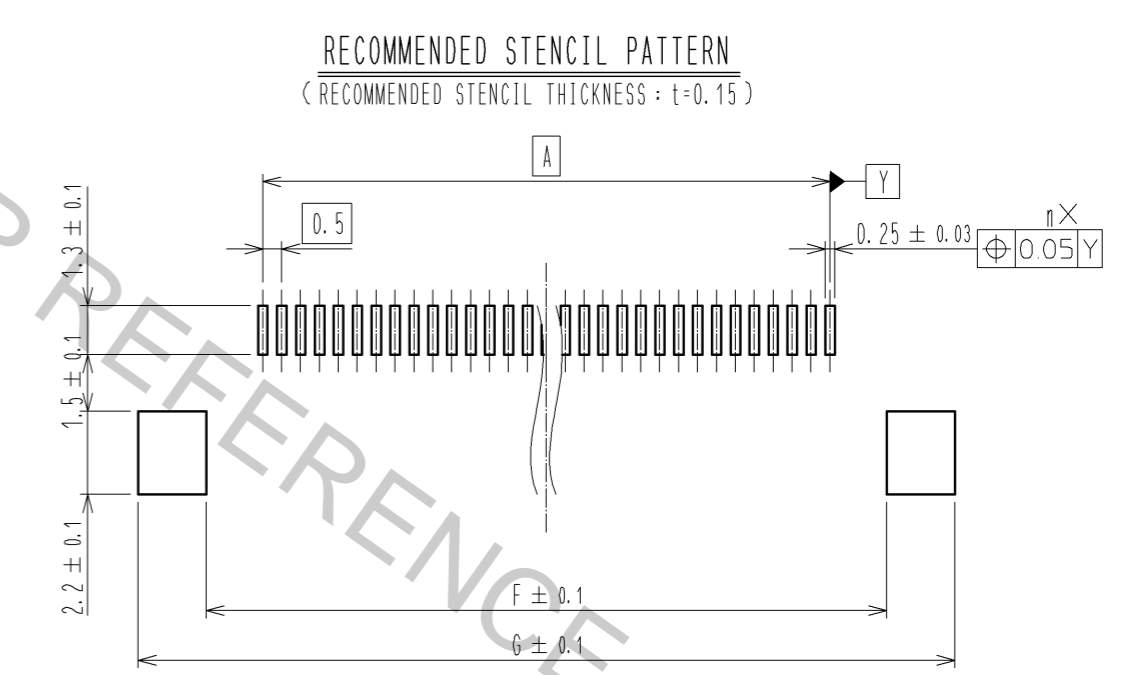
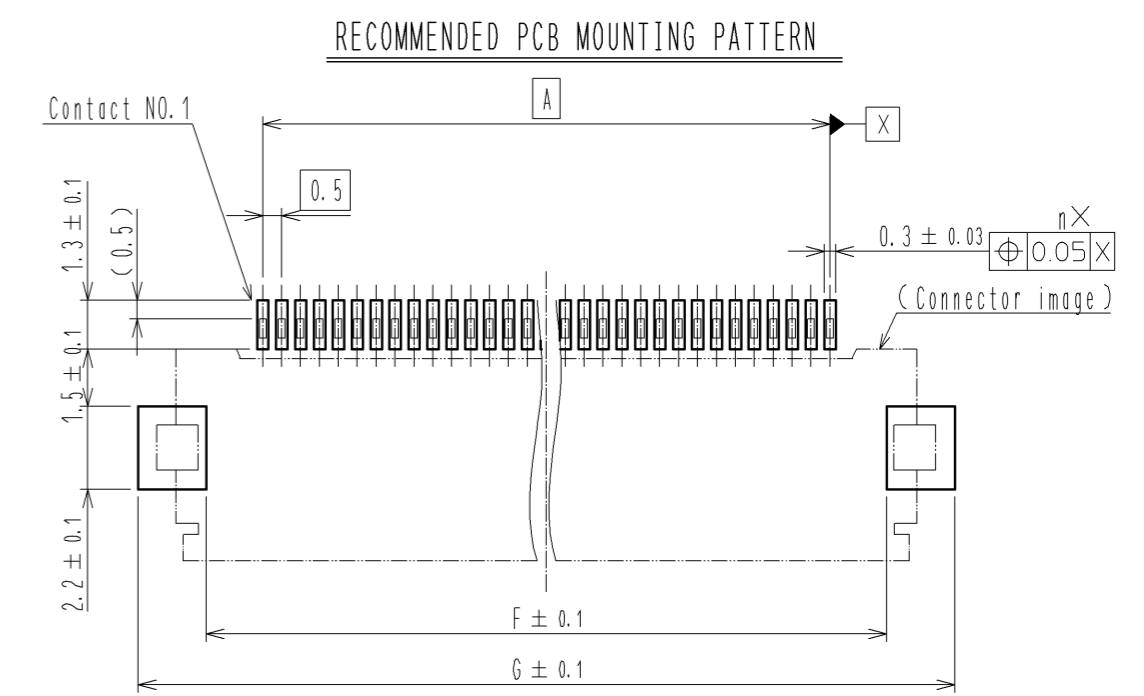
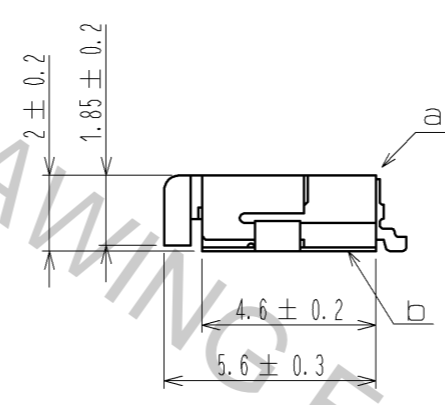
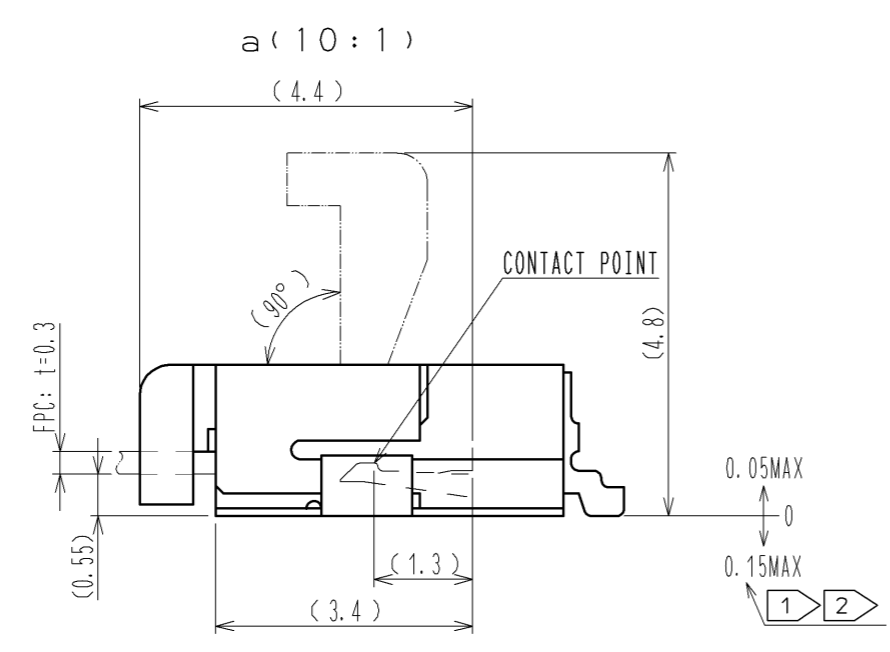
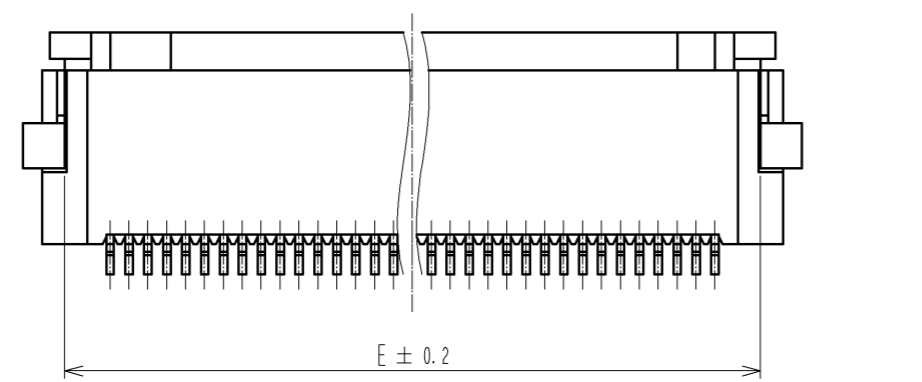
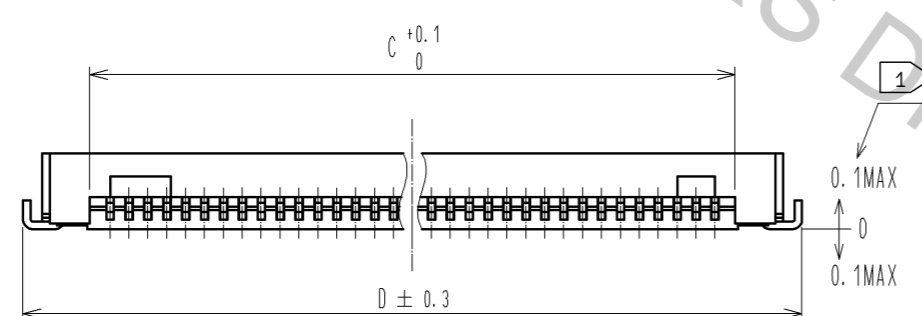
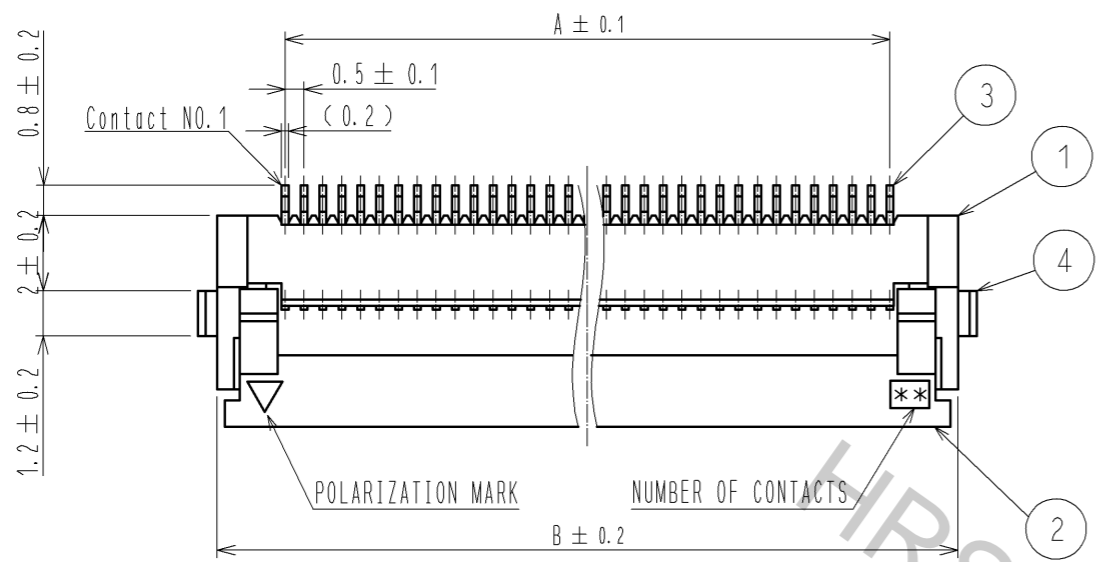

NOTE ① REFERENCE IS b.  
 ② LEAD CO-PLANARITY SHALL BE 0.1 MAX.  
 ③ 'n' REPRESENTS THE NUMBER OF CONTACTS.

< 35 CONTACT OR MORE >

<b>HRS</b>	DRAWING NO.	EDC3-150229-11
	PART NO.	FH12-**S-0.5SH(55)
	CODE NO.	CL586
		△ 2/5

Jun.1.2018 Copyright 2018 HIROSE ELECTRIC CO., LTD. All Rights Reserved.  
 In case of consideration for using Automotive equipment /  
 device which demand high reliability, kindly contact our sales window correspondents.

RECOMMENDED FPC/FFC (15:1)

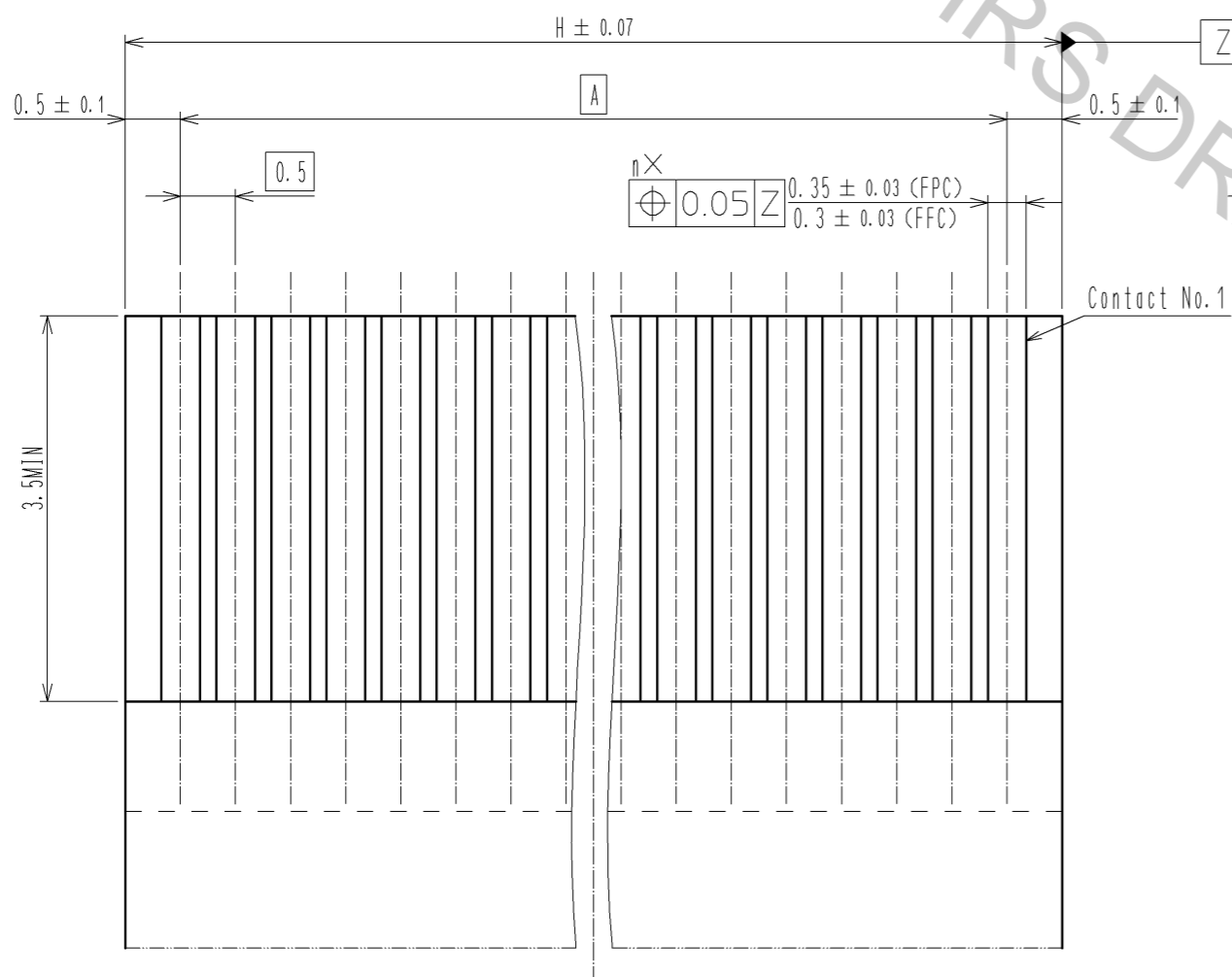

4 THICKNESS OF SUPPORTING TAPE SHALL BE 0.188(7.5MIL) MIN.

FPC CONFIGURATION (REFERENCE EXAMPLE) (SCALE:FREE)

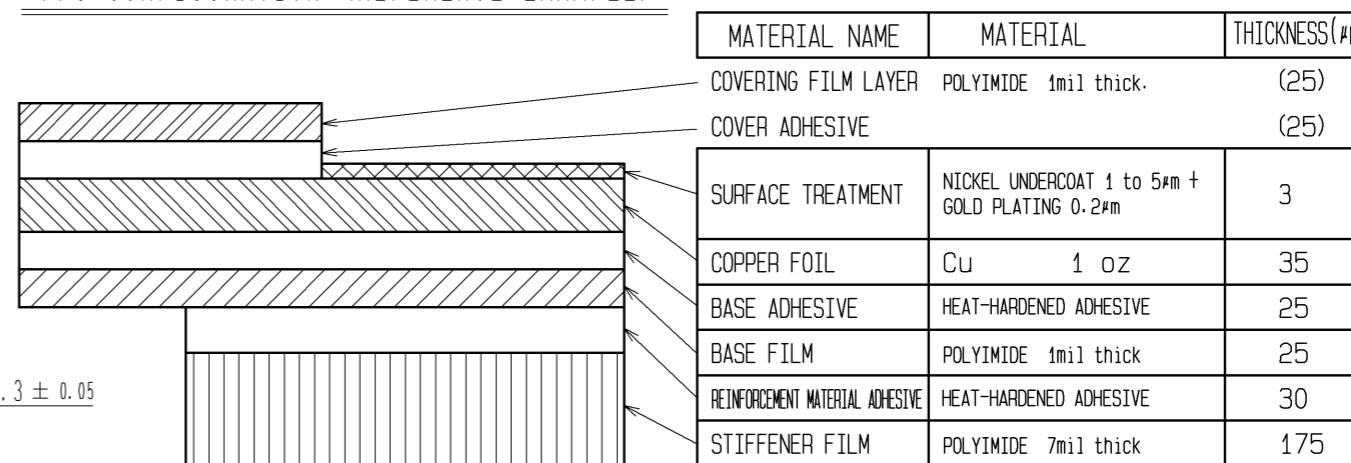

FFC CONFIGURATION (REFERENCE EXAMPLE) (SCALE:FREE)

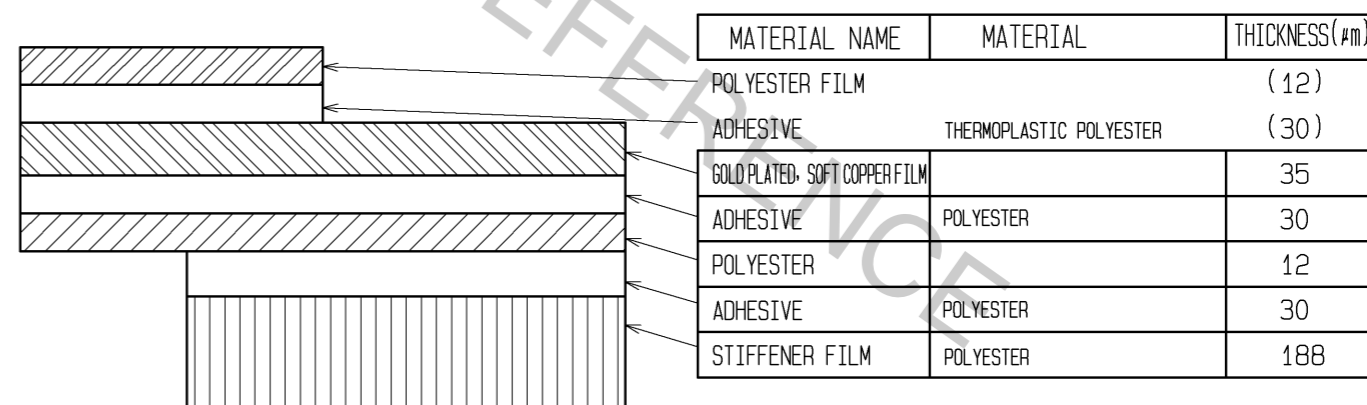

<b>HRS</b>	DRAWING NO.	EDC3-150229-11
	PART NO.	FH12-**S-0.5SH(55)
	CODE NO.	CL586

3/5

EMBOSSED CARRIER TAPE DIMENSION(2:1)

TAPE WIDTH:32mm MIN

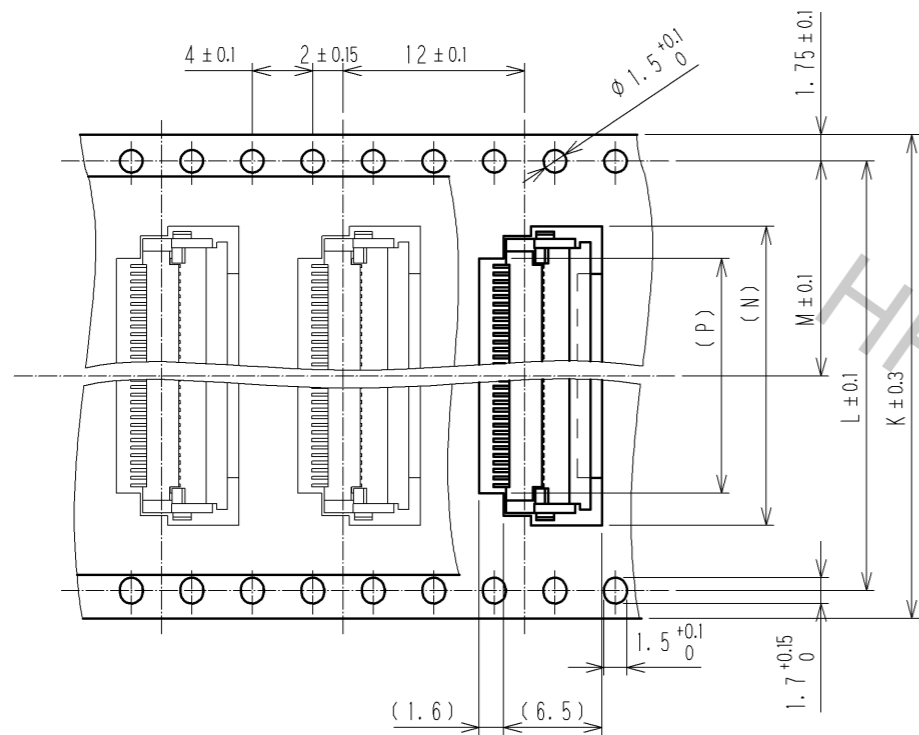

DIRECTION OF UNREELING



TAPE WIDTH:24mm MAX

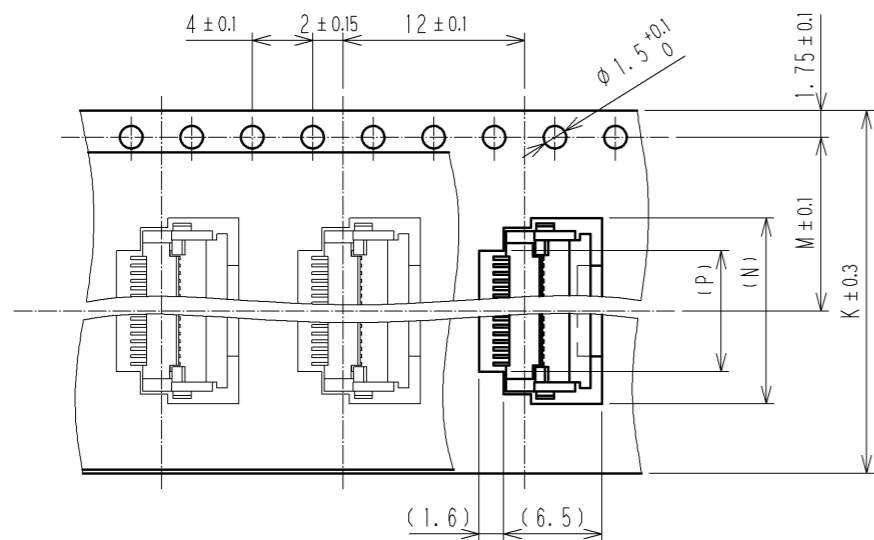

DIRECTION OF UNREELING

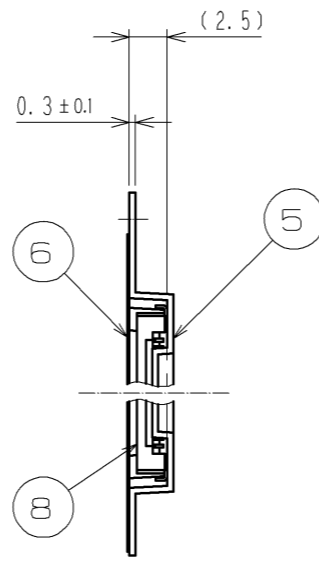
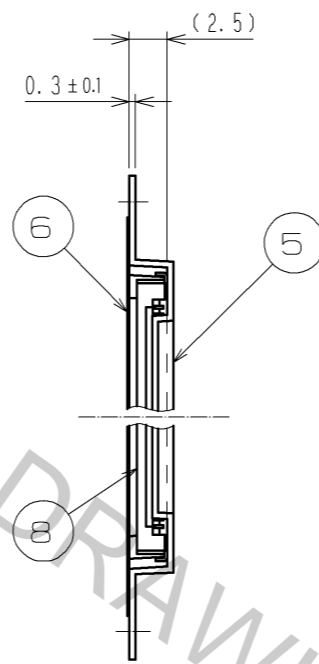

REEL DIMENSION (FREE)

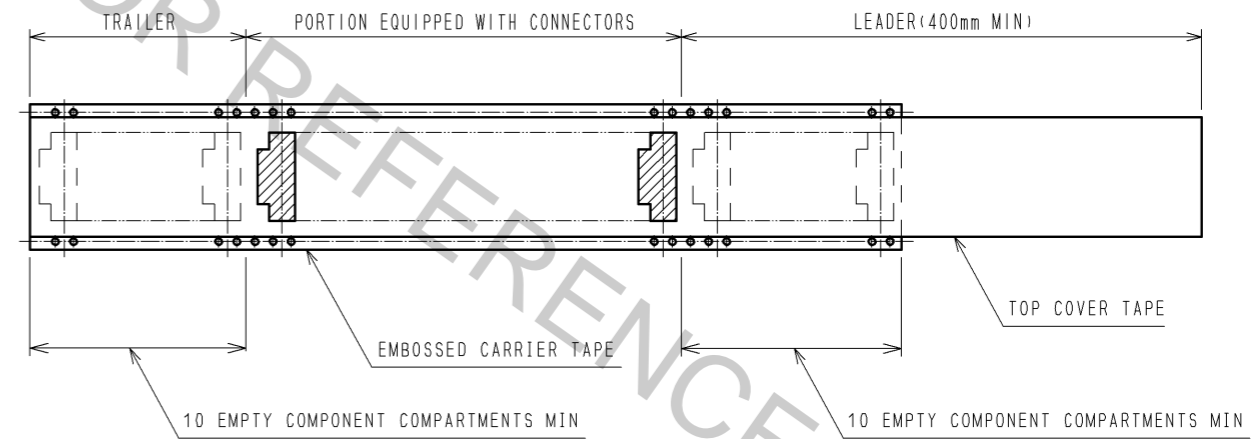
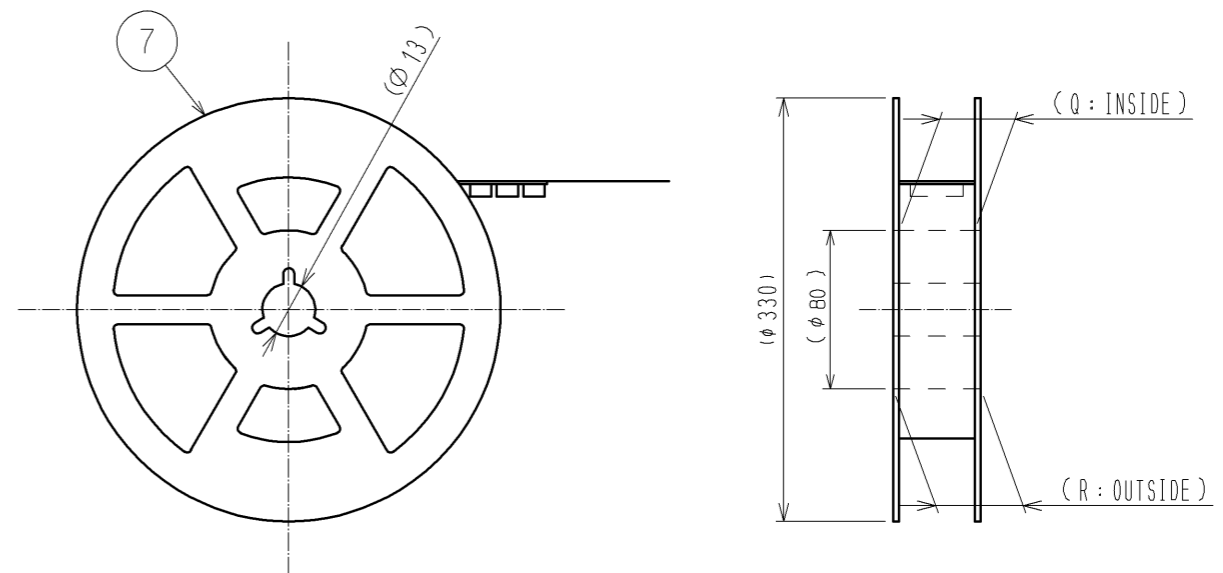

- 5 THE DIMENSIONS IN PARENTHESES ARE FOR REFERENCE.
- 6 PER REEL:2000 CONNECTORS.
- 7 SEE DIMENSION TABLE IN THE APPENDIX.

<DRAWING FOR PACKING>

<b>HRS</b>	DRAWING NO.	EDC3-150229-11
	PART NO.	FH12-**S-0.5SH(55)
	CODE NO.	CL586
		4/5

Jun.1.2018 Copyright 2018 HIROSE ELECTRIC CO., LTD. All Rights Reserved. In case of consideration for using Automotive equipment / device which demand high reliability, kindly contact our sales window correspondents.

Jun.1.2018 Copyright 2018 HIROSE ELECTRIC CO., LTD. All Rights Reserved.  
 In case of consideration for using Automotive equipment /  
 device which demand high reliability, kindly contact our sales window correspondents.

PART NO.	CODE NO.	NUMBER OF CONTACT	DIMENSION TABLE OF CONNECTOR, FPC, FFC, PCB MOUNTING PATTERN AND STENCIL PATTERN								DIMENSION TABLE OF DRAWING FOR PACKING						
			A	B	C	D	E	F	G	H	K	L	M	N	P	Q	R
FH12- 6S-0.5SH(55)	CL586-0582-5-55	6	2.5	6.1	3.57	7.1	4.9	4.5	8.1	3.5	16	—	7.5	7.8	3.5	17.4	21.4
FH12- 8S-0.5SH(55)	CL586-0744-5-55	8	3.5	7.1	4.57	8.1	5.9	5.5	9.1	4.5	16	—	7.5	8.8	4.5	17.4	21.4
FH12-10S-0.5SH(55)	CL586-0522-3-55	10	4.5	8.1	5.57	9.1	6.9	6.5	10.1	5.5	16	—	7.5	9.8	5.5	17.4	21.4
FH12-11S-0.5SH(55)	CL586-0600-5-55	11	5	8.6	6.07	9.6	7.4	7	10.6	6	16	—	7.5	10.3	6	17.4	21.4
FH12-12S-0.5SH(55)	CL586-0704-0-55	12	5.5	9.1	6.57	10.1	7.9	7.5	11.1	6.5	24	—	11.5	10.8	6.5	25.4	29.4
FH12-13S-0.5SH(55)	CL586-0549-0-55	13	6	9.6	7.07	10.6	8.4	8	11.6	7	24	—	11.5	11.3	7	25.4	29.4
FH12-14S-0.5SH(55)	CL586-0533-0-55	14	6.5	10.1	7.57	11.1	8.9	8.5	12.1	7.5	24	—	11.5	11.8	7.5	25.4	29.4
FH12-15S-0.5SH(55)	CL586-0523-6-55	15	7	10.6	8.07	11.6	9.4	9	12.6	8	24	—	11.5	12.3	8	25.4	29.4
FH12-16S-0.5SH(55)	CL586-0531-4-55	16	7.5	11.1	8.57	12.1	9.9	9.5	13.1	8.5	24	—	11.5	12.8	8.5	25.4	29.4
FH12-17S-0.5SH(55)	CL586-0606-1-55	17	8	11.6	9.07	12.6	10.4	10	13.6	9	24	—	11.5	13.3	9	25.4	29.4
FH12-18S-0.5SH(55)	CL586-0530-1-55	18	8.5	12.1	9.57	13.1	10.9	10.5	14.1	9.5	24	—	11.5	13.8	9.5	25.4	29.4
FH12-19S-0.5SH(55)	CL586-0534-2-55	19	9	12.6	10.07	13.6	11.4	11	14.6	10	24	—	11.5	14.3	10	25.4	29.4
FH12-20S-0.5SH(55)	CL586-0524-9-55	20	9.5	13.1	10.57	14.1	11.9	11.5	15.1	10.5	24	—	11.5	14.8	10.5	25.4	29.4
FH12-22S-0.5SH(55)	CL586-0532-7-55	22	10.5	14.1	11.57	15.1	12.9	12.5	16.1	11.5	24	—	11.5	15.8	11.5	25.4	29.4
FH12-24S-0.5SH(55)	CL586-0521-0-55	24	11.5	15.1	12.57	16.1	13.9	13.5	17.1	12.5	24	—	11.5	16.8	12.5	25.4	29.4
FH12-25S-0.5SH(55)	CL586-0692-3-55	25	12	15.6	13.07	16.6	14.4	14	17.6	13	24	—	11.5	17.3	13	25.4	29.4
FH12-26S-0.5SH(55)	CL586-0576-2-55	26	12.5	16.1	13.57	17.1	14.9	14.5	18.1	13.5	24	—	11.5	17.8	13.5	25.4	29.4
FH12-28S-0.5SH(55)	CL586-0612-4-55	28	13.5	17.1	14.57	18.1	15.9	15.5	19.1	14.5	32	28.4	14.2	18.8	14.5	33.4	37.4
FH12-30S-0.5SH(55)	CL586-0525-1-55	30	14.5	18.1	15.57	19.1	16.9	16.5	20.1	15.5	32	28.4	14.2	19.8	15.5	33.4	37.4
FH12-32S-0.5SH(55)	CL586-0681-7-55	32	15.5	19.1	16.57	20.1	17.9	17.5	21.1	16.5	32	28.4	14.2	20.8	16.5	33.4	37.4
FH12-33S-0.5SH(55)	CL586-0520-8-55	33	16	19.6	17.07	20.6	18.4	18	21.6	17	32	28.4	14.2	21.3	17	33.4	37.4
FH12-34S-0.5SH(55)	CL586-0617-8-55	34	16.5	20.1	17.57	21.1	18.9	18.5	22.1	17.5	32	28.4	14.2	21.8	17.5	33.4	37.4
FH12-35S-0.5SH(55)	CL586-0740-4-55	35	17	20.6	18.07	21.6	19.4	19	22.6	18	44	40.4	20.2	22.3	18	45.4	49.4
FH12-36S-0.5SH(55)	CL586-0526-4-55	36	17.5	21.1	18.57	22.1	19.9	19.5	23.1	18.5	44	40.4	20.2	22.8	18.5	45.4	49.4
FH12-40S-0.5SH(55)	CL586-0527-7-55	40	19.5	23.1	20.57	24.1	21.9	21.5	25.1	20.5	44	40.4	20.2	24.8	20.5	45.4	49.4
FH12-45S-0.5SH(55)	CL586-0528-0-55	45	22	25.6	23.07	26.6	24.4	24	27.6	23	44	40.4	20.2	27.3	23	45.4	49.4
FH12-50S-0.5SH(55)	CL586-0529-2-55	50	24.5	28.1	25.57	29.1	26.9	26.5	30.1	25.5	44	40.4	20.2	29.8	25.5	45.4	49.4
FH12-53S-0.5SH(55)	CL586-0595-7-55	53	26	29.6	27.07	30.6	28.4	28	31.6	27	44	40.4	20.2	31.3	27	45.4	49.4

<b>HRS</b>	DRAWING NO.	EDC3-150229-11
	PART NO.	FH12- ** S-0.5SH(55)
	CODE NO.	CL586
		△ 5/5