

CR35H – 3535 Ceramic LED



Introduction

Features

- Package : Ceramic Substrate LED Package
- View Angle: 125 °
- Precondition : JEDEC Level 2
- Dimension : 3.5 x 3.5 x 1.89 mm
- ESD withstand Voltage : up to ± 5 KV [HBM]
- Reliability Test : IES-LM-80-08 qualified

Applications

- INDOOR LIGHTING : Spot light, Down light
- OUTDOOR LIGHTING : Street light, Security light, Tunnel light, Parking lots light
- INDUSTRIAL LIGHTING : High-bay light, Low-bay light
- CONSUMER LIGHTING : Torch light

SAMSUNG ELECTRONICS

95, Samsung2-Ro, Giheung-Gu,
Yongin-City, Gyeonggi-Do 446-711, KOREA

Copyright © 2009-2011 SAMSUNG ELECTRONICS Co.,Ltd. All rights reserved. The information in this document is subject to change without notice. SAMSUNG,  SAMSUNG is a registered trademark of SAMSUNG ELECTRONICS.

Contents

1. Luminous Flux Characteristics	-----	3
2. Characteristics	-----	8
3. Typical Characteristics Graph	-----	9
4. Outline Drawing & Dimension	-----	15
5. Reliability Test Items and Conditions	-----	16
6. Solder Conditions	-----	17
7. Tape & Reel	-----	18
8. Label Structure	-----	19
9. Packing Structure	-----	20
10. Precaution For Use	-----	22
11. Hazard Substance Analysis	-----	23
12. Revision History	-----	26

1. Luminous Flux Characteristics (T_j = 25°C)

Nominal CCT	Minimum CRI ⁽¹⁾	Sorting condition lm ² @350mA		Calculated Minimum lm ²			Product Code	BIN Structure
		Rank	Min lm ²	@700mA	@1000mA	@1500mA		
2700K	80	F5	90	164	219	301	SPHWHTL3D305E6W0F5	Whole
							SPHWHTL3D305E6WUF5	Half
							SPHWHTL3D305E6WPF5	M4
							SPHWHTL3D305E6WMF5	M3
							SPHWHTL3D305E6WKF5	Kitting
		G4	100	182	244	334	SPHWHTL3D305E6W0G4	Whole
							SPHWHTL3D305E6WUG4	Half
							SPHWHTL3D305E6WPG4	M4
							SPHWHTL3D305E6WMG4	M3
							SPHWHTL3D305E6WKG4	Kitting
		H3	110	200	268	368	SPHWHTL3D305E6W0H3	Whole
							SPHWHTL3D305E6WUH3	Half
							SPHWHTL3D305E6WPH3	M4
							SPHWHTL3D305E6WMH3	M3
							SPHWHTL3D305E6WKH3	Kitting
3000K	80	F5	90	164	219	301	SPHWHTL3D305E6V0F5	Whole
							SPHWHTL3D305E6VUF5	Half
							SPHWHTL3D305E6VPF5	M4
							SPHWHTL3D305E6VMF5	M3
							SPHWHTL3D305E6VKF5	Kitting
		G4	100	182	244	334	SPHWHTL3D305E6V0G4	Whole
							SPHWHTL3D305E6VUG4	Half
							SPHWHTL3D305E6VPG4	M4
							SPHWHTL3D305E6VMG4	M3
							SPHWHTL3D305E6VKG4	Kitting
		H3	110	200	268	368	SPHWHTL3D305E6V0H3	Whole
							SPHWHTL3D305E6VUH3	Half
							SPHWHTL3D305E6VPH3	M4
							SPHWHTL3D305E6VMH3	M3
							SPHWHTL3D305E6VKH3	Kitting



1. Luminous Flux Characteristics ($T_j = 25^\circ\text{C}$) (Continued)

Nominal CCT	Minimum CRI ¹⁾	Sorting condition lm ² @350mA		Calculated Minimum lm ²			Product Code	BIN Structure
		Rank	Min lm ²	@700mA	@1000mA	@1500mA		
3500K	80	F5	90	164	219	301	SPHWHTL3D305E6U0F5	Whole
							SPHWHTL3D305E6UUF5	Half
							SPHWHTL3D305E6UPF5	M4
							SPHWHTL3D305E6UMF5	M3
							SPHWHTL3D305E6UKF5	Kitting
		G4	100	182	244	334	SPHWHTL3D305E6U0G4	Whole
							SPHWHTL3D305E6UUG4	Half
							SPHWHTL3D305E6UPG4	M4
							SPHWHTL3D305E6UMG4	M3
							SPHWHTL3D305E6UKG4	Kitting
		H3	110	200	268	368	SPHWHTL3D305E6U0H3	Whole
							SPHWHTL3D305E6UUH3	Half
							SPHWHTL3D305E6UPH3	M4
							SPHWHTL3D305E6UMH3	M3
							SPHWHTL3D305E6UKH3	Kitting



1. Luminous Flux Characteristics (T_j = 25°C) (Continued)

Nominal CCT	Minimum CRI ¹⁾	Sorting condition Im ²⁾ @350mA		Calculated Minimum Im ²⁾			Product Code	BIN Structure
		Rank	Min Im ²⁾	@700mA	@1000mA	@1500mA		
4000K	80	F5	90	164	219	301	SPHWHTL3D305E6T0F5	Whole
							SPHWHTL3D305E6TUF5	Half
							SPHWHTL3D305E6TPF5	M4
							SPHWHTL3D305E6TMF5	M3
							SPHWHTL3D305E6TKF5	Kitting
		G4	100	182	244	334	SPHWHTL3D305E6T0G4	Whole
							SPHWHTL3D305E6TUG4	Half
							SPHWHTL3D305E6TPG4	M4
							SPHWHTL3D305E6TMG4	M3
							SPHWHTL3D305E6TKG4	Kitting
		H3	110	200	268	368	SPHWHTL3D305E6T0H3	Whole
							SPHWHTL3D305E6TUH3	Half
							SPHWHTL3D305E6TPH3	M4
							SPHWHTL3D305E6TMH3	M3
							SPHWHTL3D305E6TKH3	Kitting
		J2	120	218	293	401	SPHWHTL3D305E6T0J2	Whole
							SPHWHTL3D305E6TUJ2	Half
							SPHWHTL3D305E6TPJ2	M4
							SPHWHTL3D305E6TMJ2	M3
							SPHWHTL3D305E6TKJ2	Kitting



1. Luminous Flux Characteristics ($T_j = 25^\circ\text{C}$) (Continued)

Nominal CCT	Minimum CRI ¹⁾	Sorting condition lm^2 @350mA		Calculated Minimum lm^2			Product Code	BIN Structure
		Rank	Min lm^2	@700mA	@1000mA	@1500mA		
5000K	70	H5	110	200	268	368	SPHWHTL3D303E6R0H5	Whole
							SPHWHTL3D303E6RTH5	M7
							SPHWHTL3D303E6RKH5	Kitting
		J4	120	218	293	401	SPHWHTL3D303E6R0J4	Whole
							SPHWHTL3D303E6RTJ4	M7
							SPHWHTL3D303E6RKJ4	Kitting
		K3	130	237	317	434	SPHWHTL3D303E6R0K3	Whole
							SPHWHTL3D303E6RTK3	M7
							SPHWHTL3D303E6RKK3	Kitting
		M2	140	254	341	468	SPHWHTL3D303E6R0M2	Whole
							SPHWHTL3D303E6RTM2	M7
							SPHWHTL3D303E6RKM2	Kitting
5700K	70	H5	110	200	268	368	SPHWHTL3D303E6Q0H5	Whole
							SPHWHTL3D303E6QTH5	M7
							SPHWHTL3D303E6QKH5	Kitting
		J4	120	218	293	401	SPHWHTL3D303E6Q0J4	Whole
							SPHWHTL3D303E6QTJ4	M7
							SPHWHTL3D303E6QKJ4	Kitting
		K3	130	237	317	434	SPHWHTL3D303E6Q0K3	Whole
							SPHWHTL3D303E6QTK3	M7
							SPHWHTL3D303E6QKK3	Kitting



1. Luminous Flux Characteristics (T_j = 25°C) (Continued)

Nominal CCT	Minimum CRI ¹⁾	Sorting condition Im ²⁾ @350mA		Calculated Minimum Im ²⁾			Product Code	BIN Structure
		Rank	Min Im ²⁾	@700mA	@1000mA	@1500mA		
6500K	70	H5	110	200	268	368	SPHWHTL3D303E6P0H5	Whole
							SPHWHTL3D303E6PTH5	M7
		J4	120	218	293	401	SPHWHTL3D303E6P0J4	Whole
							SPHWHTL3D303E6PTJ4	M7
		K3	130	237	317	434	SPHWHTL3D303E6P0K3	Whole
							SPHWHTL3D303E6PTK3	M7
7600K	68	H5	110	200	268	368	SPHWHTL3D303E6N0H5	Whole
		J4	120	218	293	401	SPHWHTL3D303E6N0J4	Whole
		K3	130	237	317	434	SPHWHTL3D303E6N0K3	Whole

Notes:

- 1) SAMSUNG ELECTRONICS maintains a tolerance of ±3.0 on CRI measurements.
- 2) SAMSUNG ELECTRONICS maintains a tolerance of ±7% on flux measurements.
- 3) Calculated flux values are for reference only.

2. Characteristics

1) Electro-optical Characteristics

Item	Unit	Min	Typ	Max
Forward voltage ¹⁾ (@350 mA, T _j = 25°C)	V	2.70	2.95	3.30
Forward voltage ¹⁾ (@700 mA, T _j = 25°C)	V		3.09	
Forward voltage ¹⁾ (@1000 mA, T _j = 25°C)	V		3.19	
Forward voltage ¹⁾ (@1500 mA, T _j = 25°C)	V		3.34	
Operation forward current (T _j = 25°C)	mA	-	-	1500
Thermal resistance R _{th,j-c}	°C/W	-	4	6
LED junction temperature T _j	°C	-	-	150
Operating temperature range T _{opr}	°C	-40	-	85
Storage temperature range T _{stg}	°C	-40	-	100
Viewing Angle	°	-	125	-

Item	Unit	3000K	5000K
Forward voltage ¹⁾ (@350 mA, T _j = 25°C)	V	2.95	
Forward voltage ¹⁾ (@350 mA, T _j = 85°C)	V	2.86	
Luminous flux (@350 mA, T _j = 25°C)	lm	110	136
Luminous flux (@350 mA, T _j = 85°C)	lm	101	125
Luminous flux (@700 mA, T _j = 85°C)	lm	184	227
Luminous flux (@1000 mA, T _j = 85°C)	lm	246	305
Luminous flux (@1500 mA, T _j = 85°C)	lm	337	417

Notes:

- 1) SAMSUNG ELECTRONICS maintains a tolerance of ±0.1V on forward voltage measurements.
- 2) Characteristics @ 85°C are for reference only.

2) Vf Rank

Parameter	Symbol	Condition	Rank	Rank	Min.	Typ.	Max.
Forward Voltage	V _F	I _F = 350mA	E6	E3	2.7	-	3.0
				H3	3.0	-	3.3

3. Typical Characteristics Graph

1) Spectrum Distribution

($T_a = 25^\circ\text{C}$)

2700K & 3000K

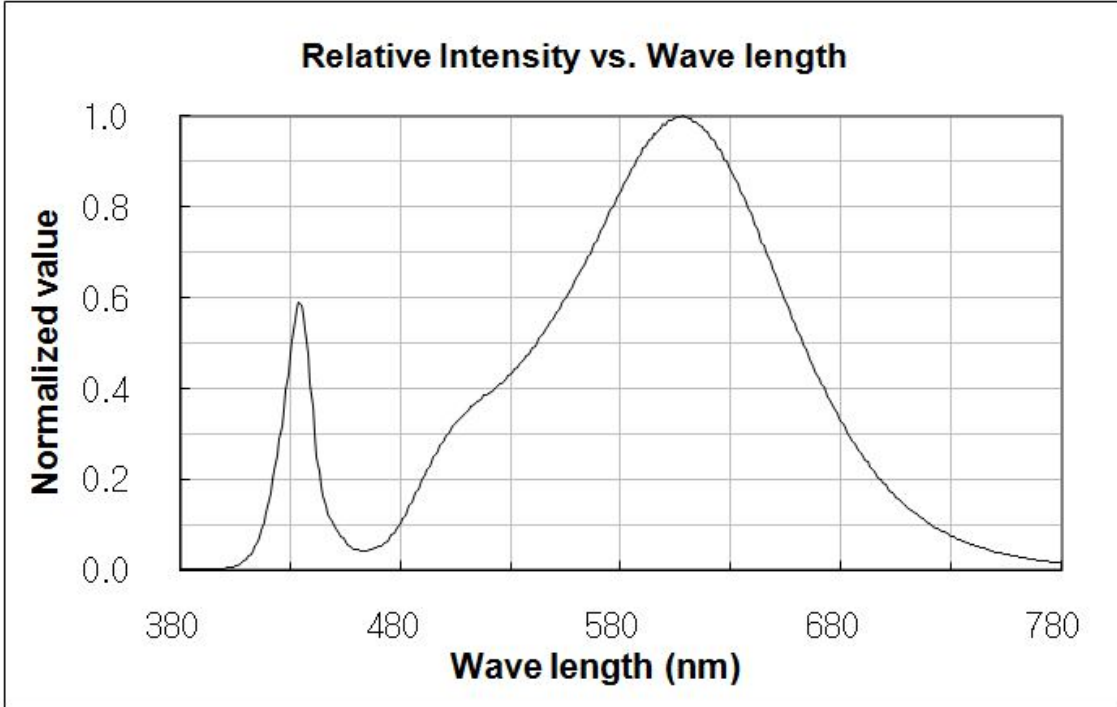

3500K & 4000K

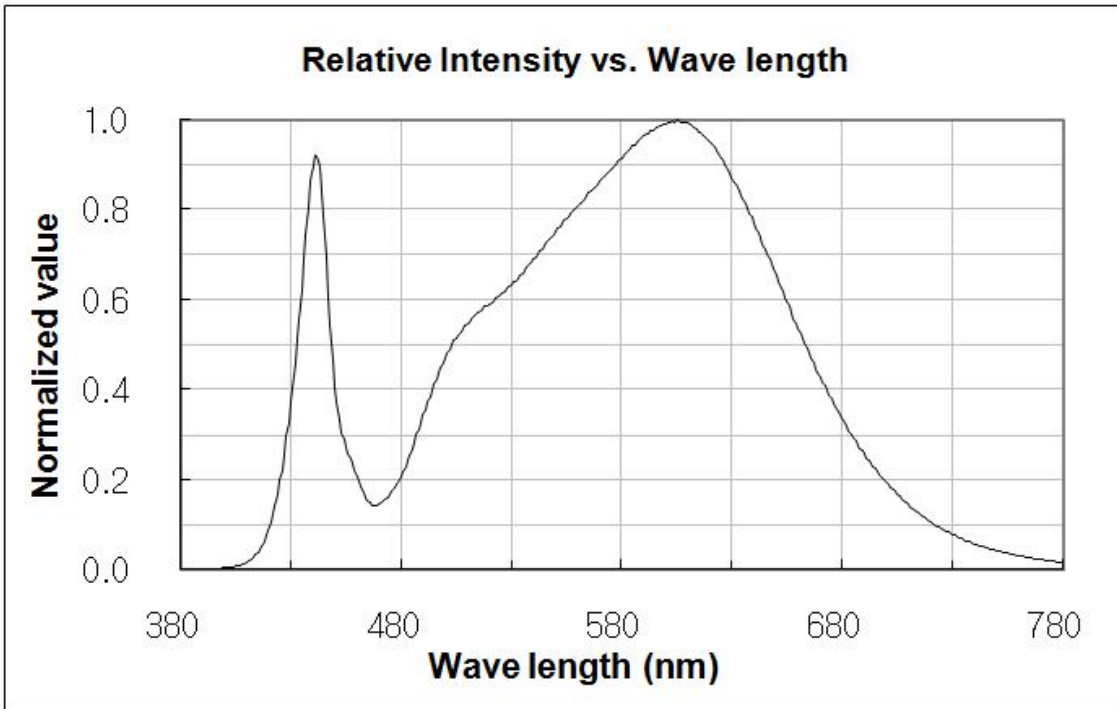

5000K & 5700K

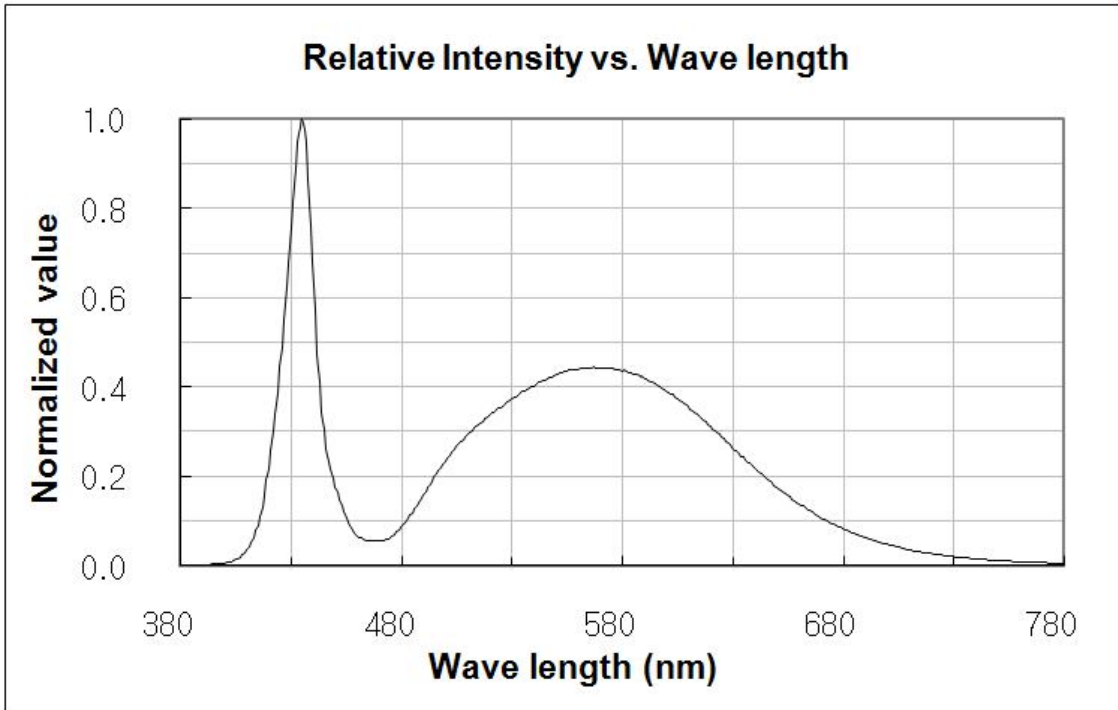

6500K & 7600K

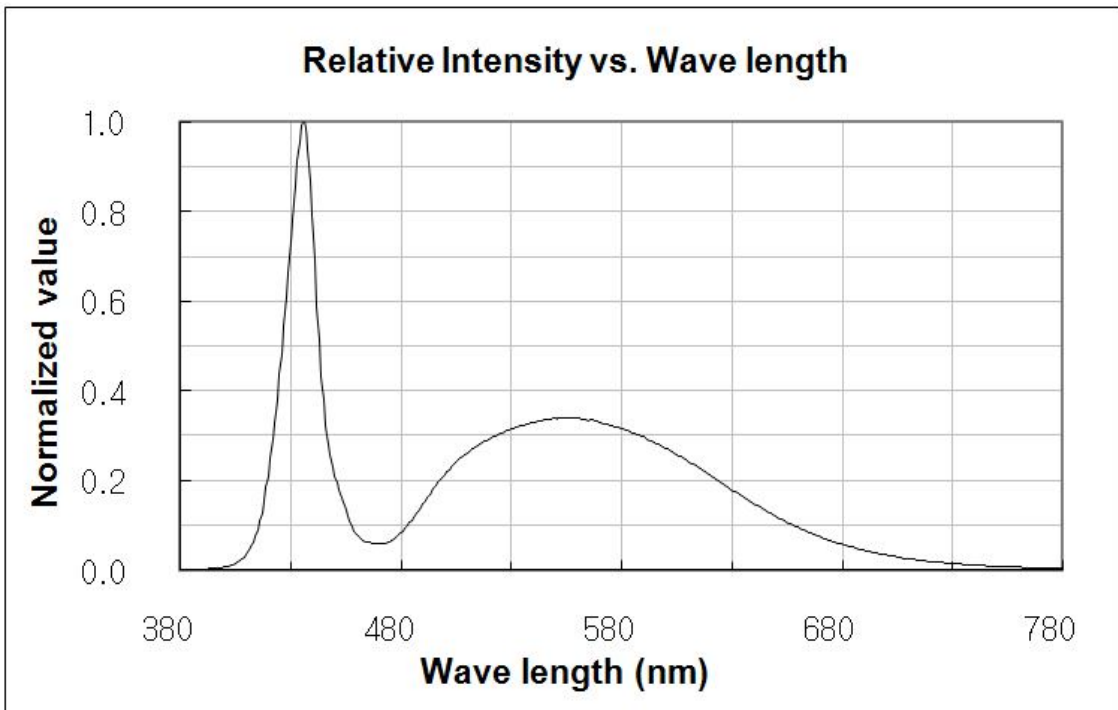

2) Forward Current Characteristics

($T_a = 25^\circ\text{C}$)

Relative Flux vs. Forward Current

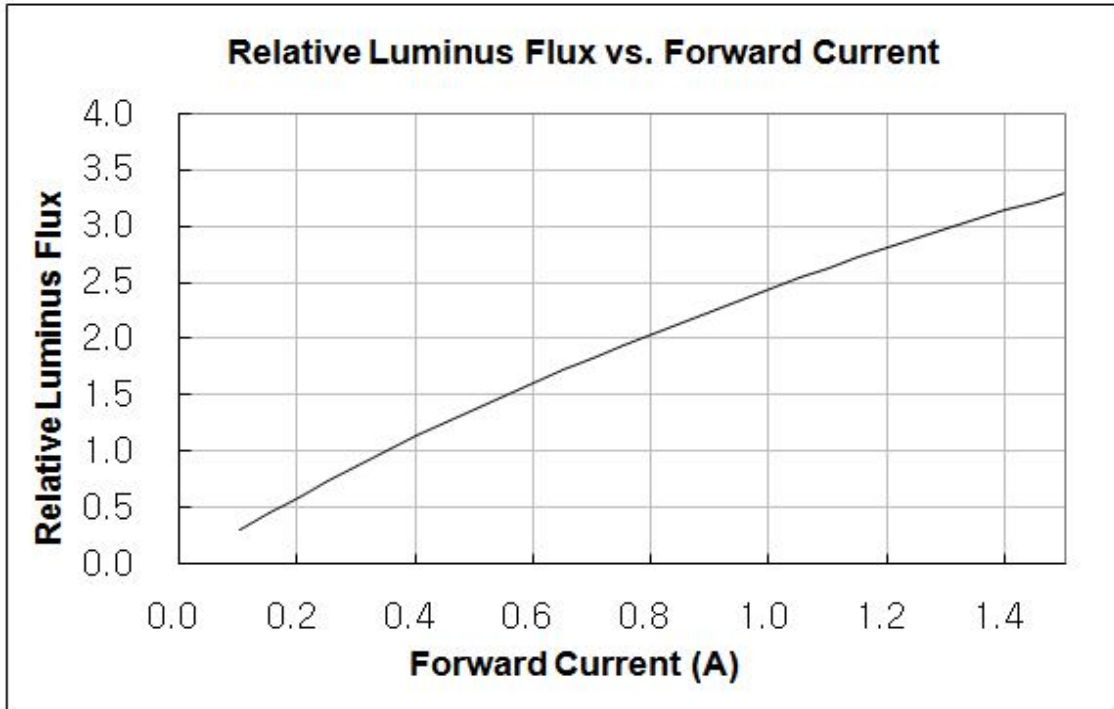

Forward Current vs. Forward Voltage

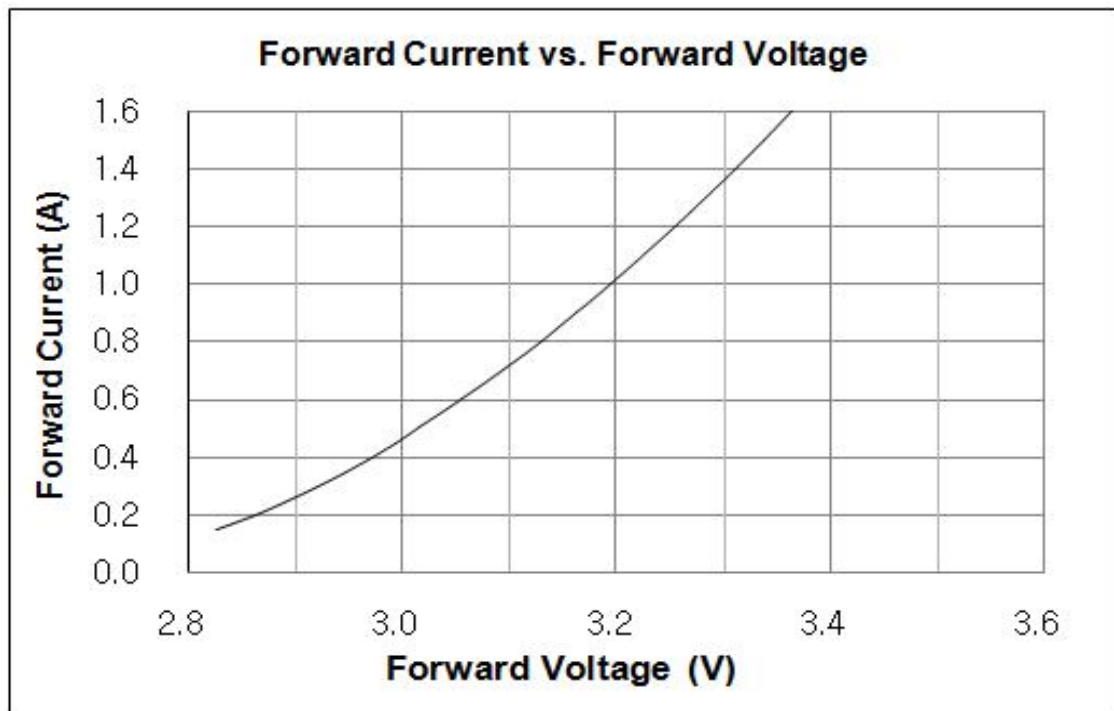

3) Temperature Characteristics

Relative Flux vs. Ts(solder temp.)

($I_F = 350\text{mA}$)

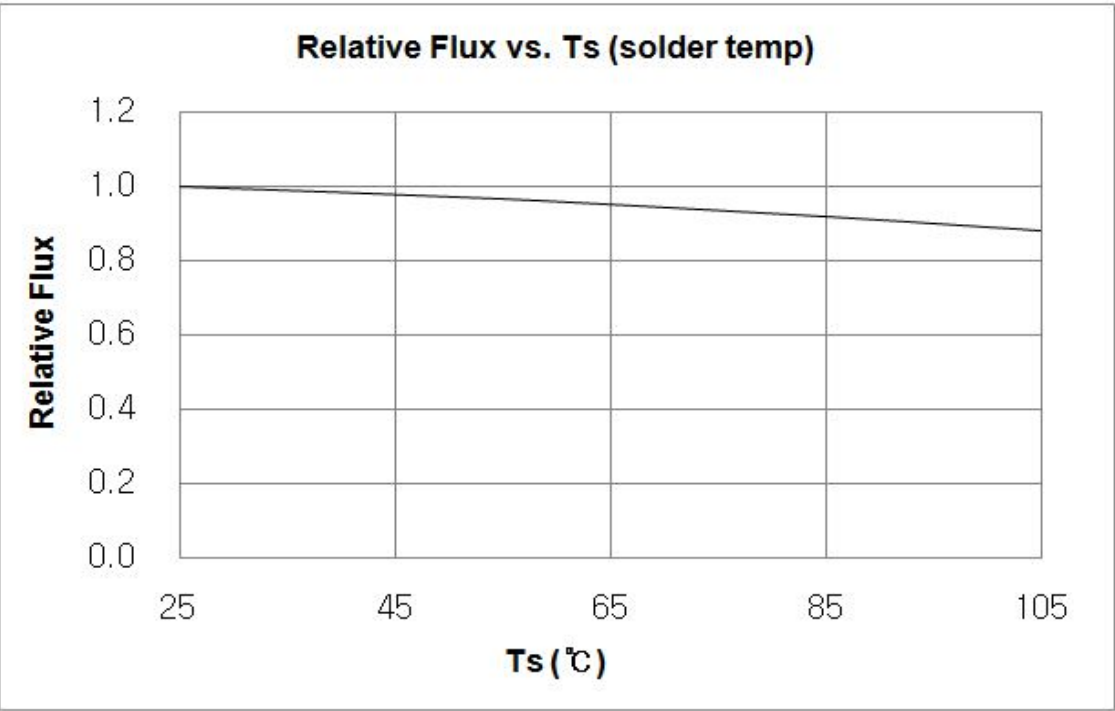

Forward Voltage vs. Ts(solder temp.)

($I_F = 350\text{mA}$)

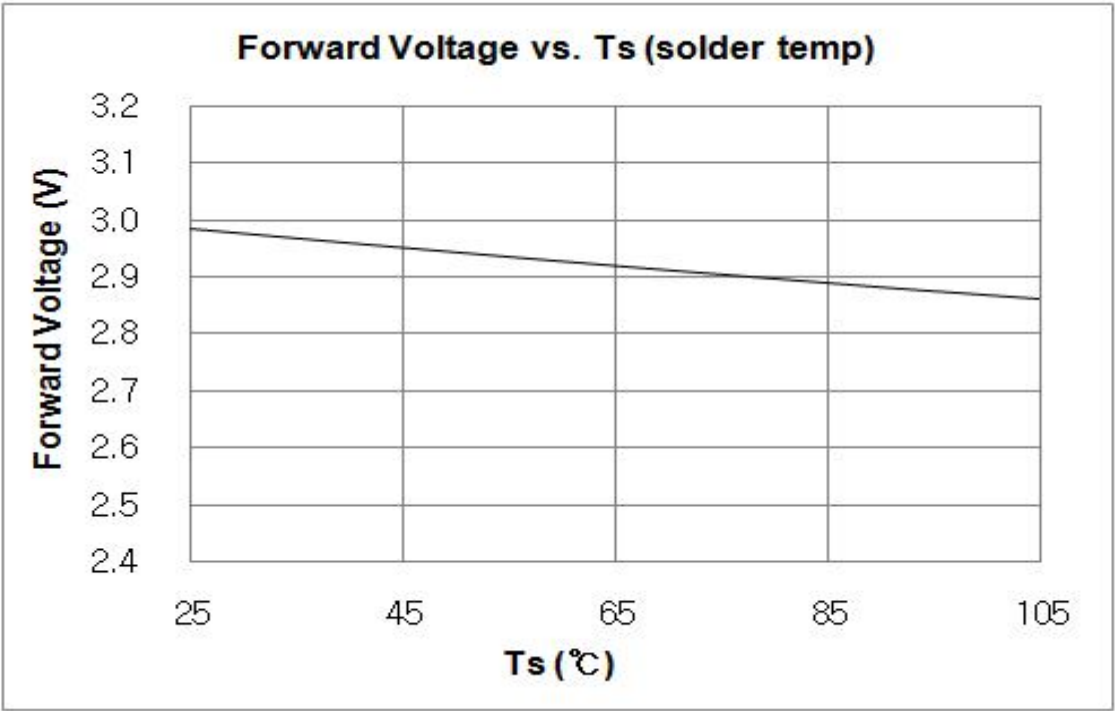

4) Color shift Characteristics

Color x,y vs. Forward Current

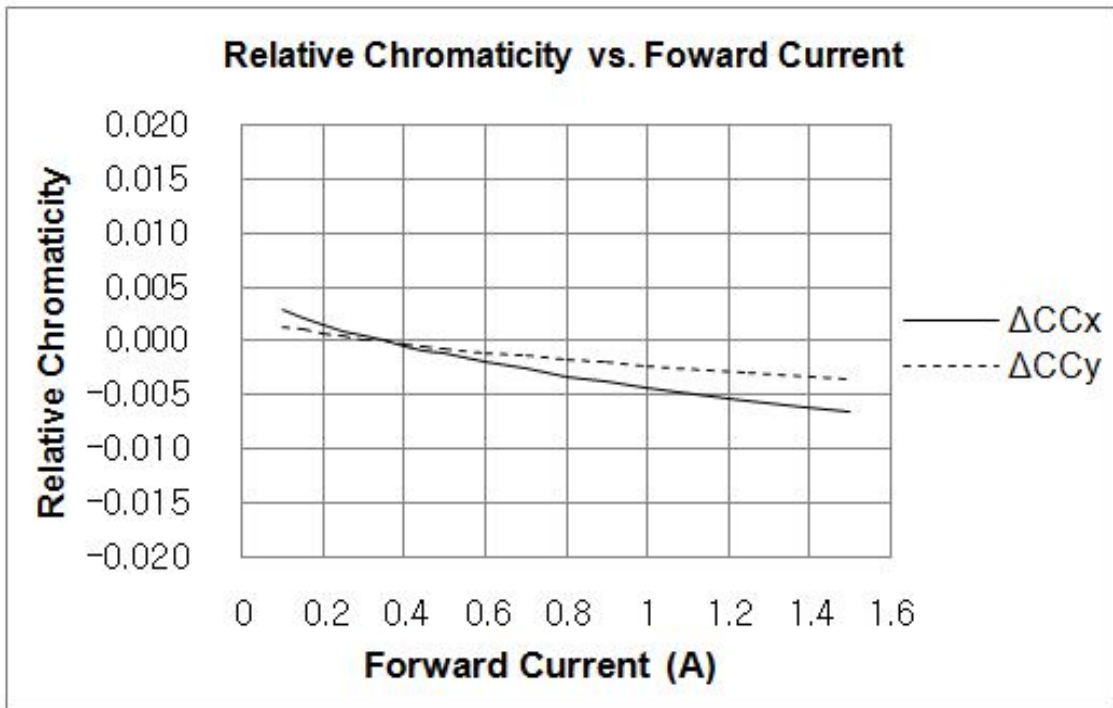

Color x,y vs. Substrate Temp.

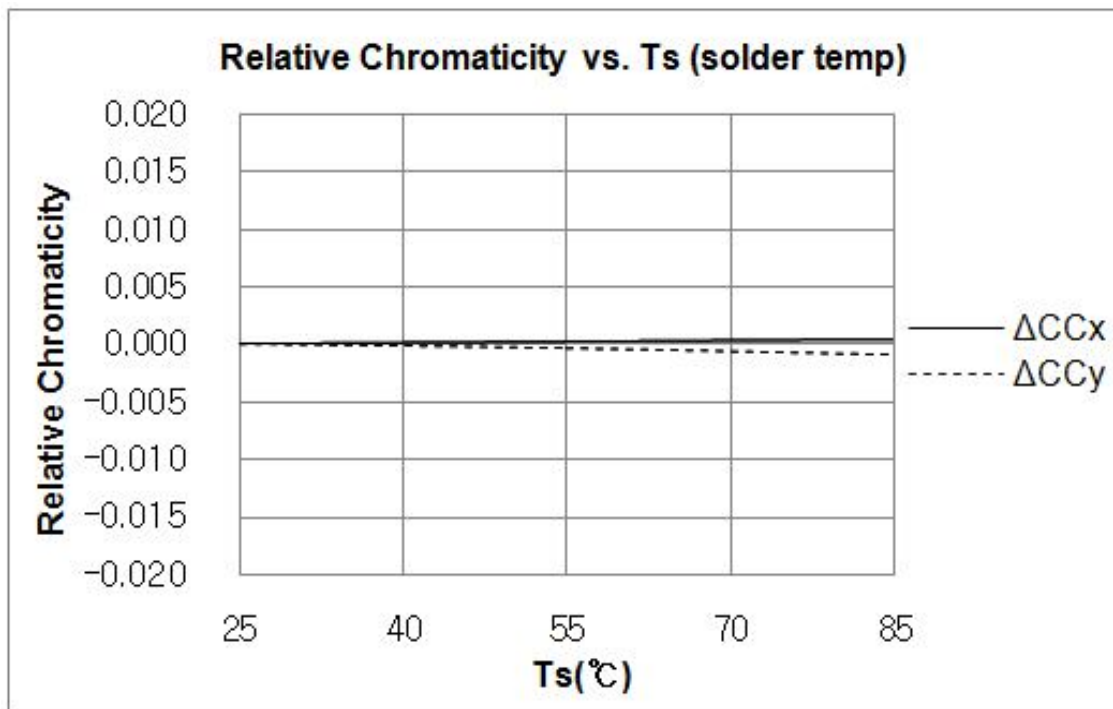

5) Derating Curve

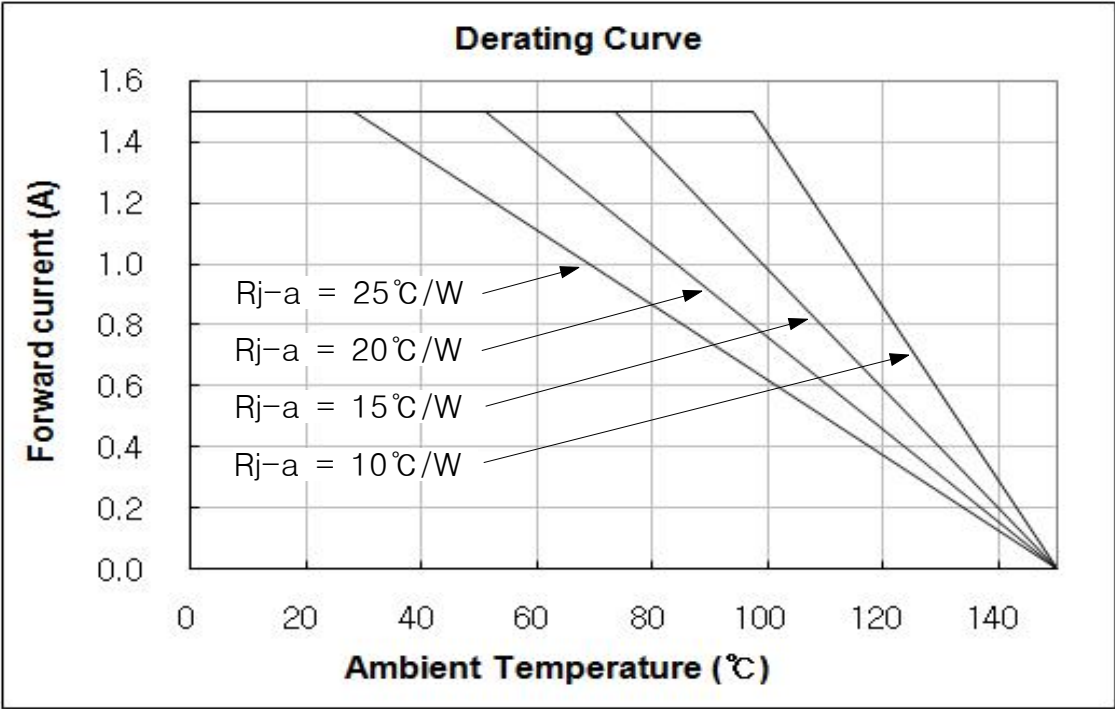

6) Viewing angle Characteristics

Viewing angle

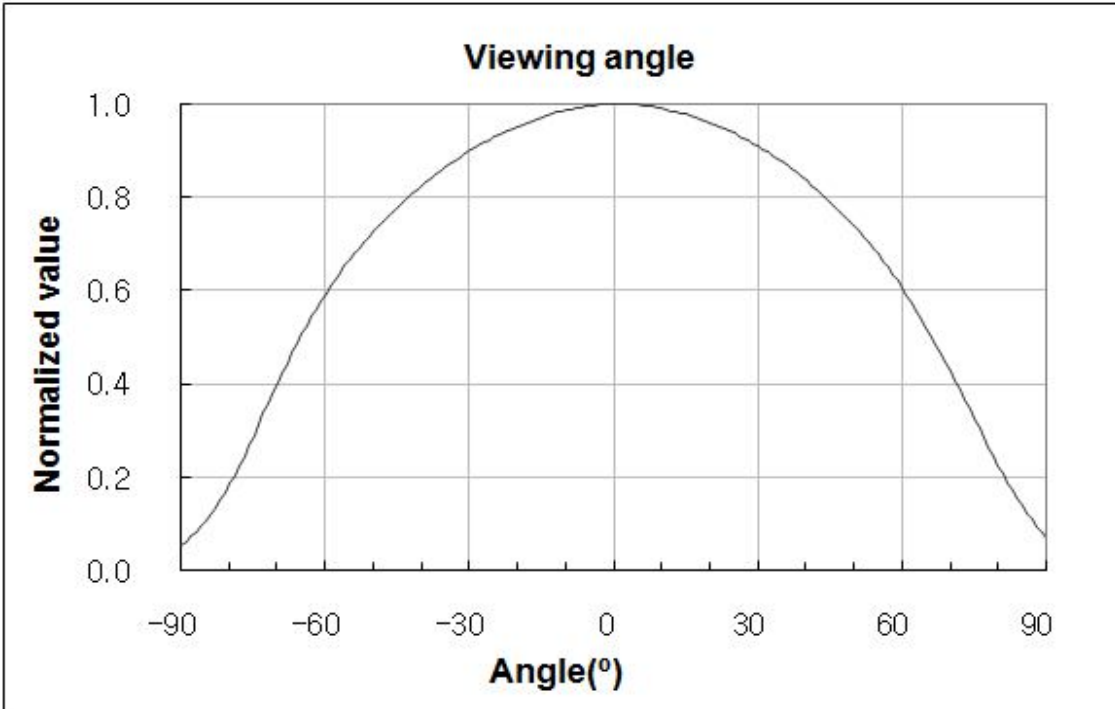

4. Outline Drawing & Dimension

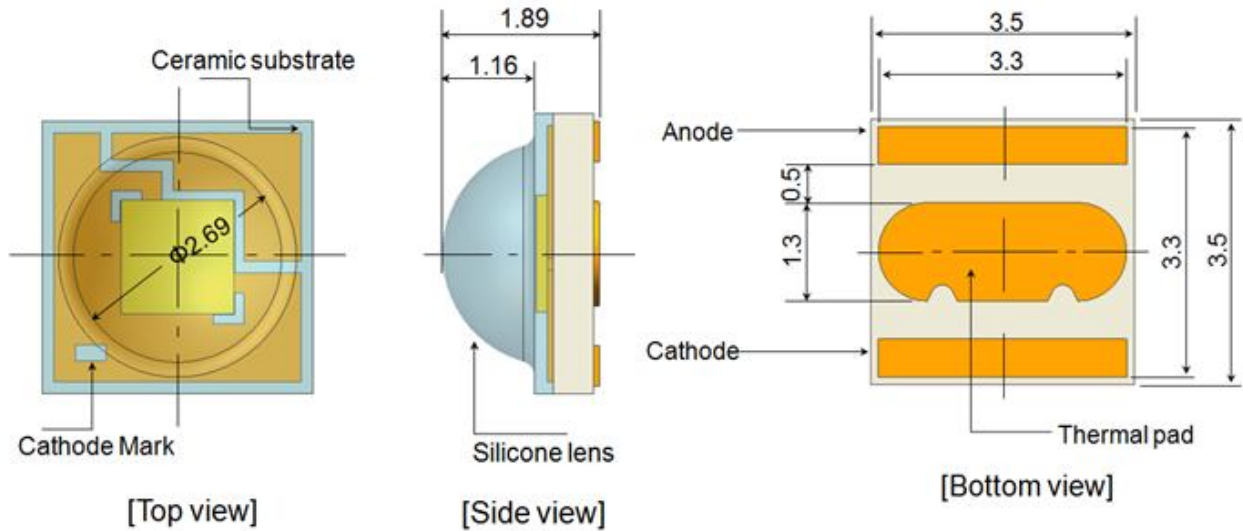

Recommended Land Pattern

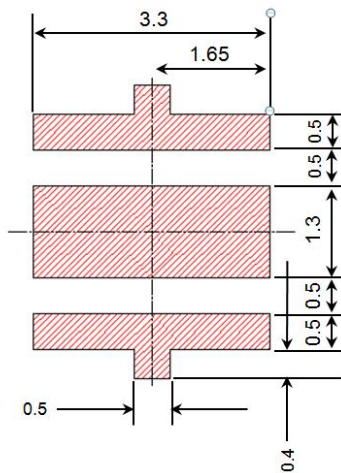

unit : mm

Tolerance : ± 0.13

- * This LED has built-in ESD protection device(s) connected in parallel to LED Chip(s).
- * The thermal pad is electrically isolated from the anode and cathode contact pads.

Ts Point & Measurement Method

- * Measure the nearest point to the thermal pad as shown below. If necessary, remove PSR of PCB to reach Ts point.
- * Thermal pad must be soldered to the PCB to dissipate heat properly. Otherwise, LED can be damaged.

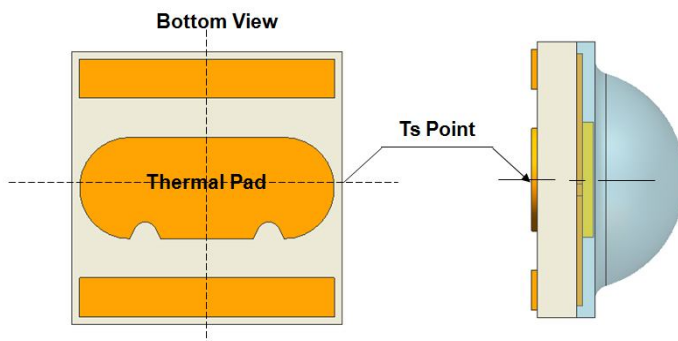

5. Reliability Test Items and Conditions

1) Test Items and Results

Test Items	Test Conditions	Test Hours/Cycles	n
Room Temperature Life Test	25℃, DC 1000 mA	1000 Hr	22
High Temperature humidity Life Test	85℃, 85%, DC 1000 mA	1000 Hr	22
High Temperature Life Test	85℃, DC 1000 mA	1000 Hr	22
Low Temperature Life Test	-40℃, DC 1000 mA	1000 Hr	22
Temperature Humidity Cycle	-10℃ ↔ 25℃ 95%RH ↔ 85℃ 95%RH 1000mA, 95%RH, 24hrs/1cycle	10 Cycles	11
Thermal Shock	-45℃/15 min ↔ 125℃/ 15 min. Temp.change within 5min.	500 Cycles	100
High Temperature Storage	Ta=120℃	1000 Hr	11
Low Temperature Storage	Ta=-40℃	1000 Hr	11
ESD(HBM)	Q1=10MΩ, R2=1.5KΩ, C=100pF, V=±5KV, 5Times	5 Times (±5kV)	5

6. Solder Conditions

1) Reflow Conditions (Pb Free)

Reflow Frequency : 2 times max.

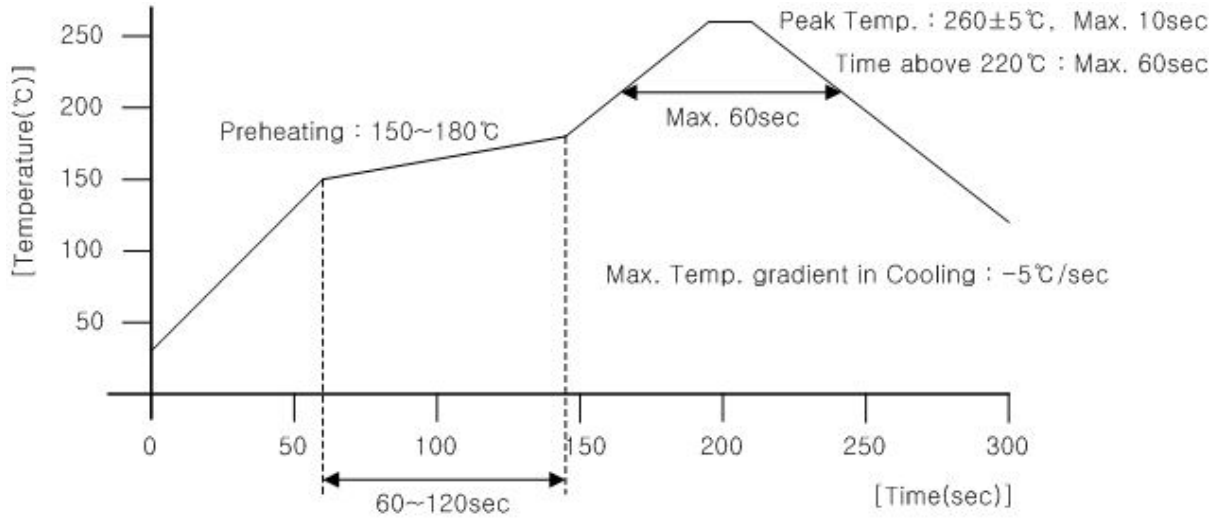

2) For Manual Soldering

Not more than 5 seconds @Max. 300°C, under soldering iron.

7. Tape And Reel

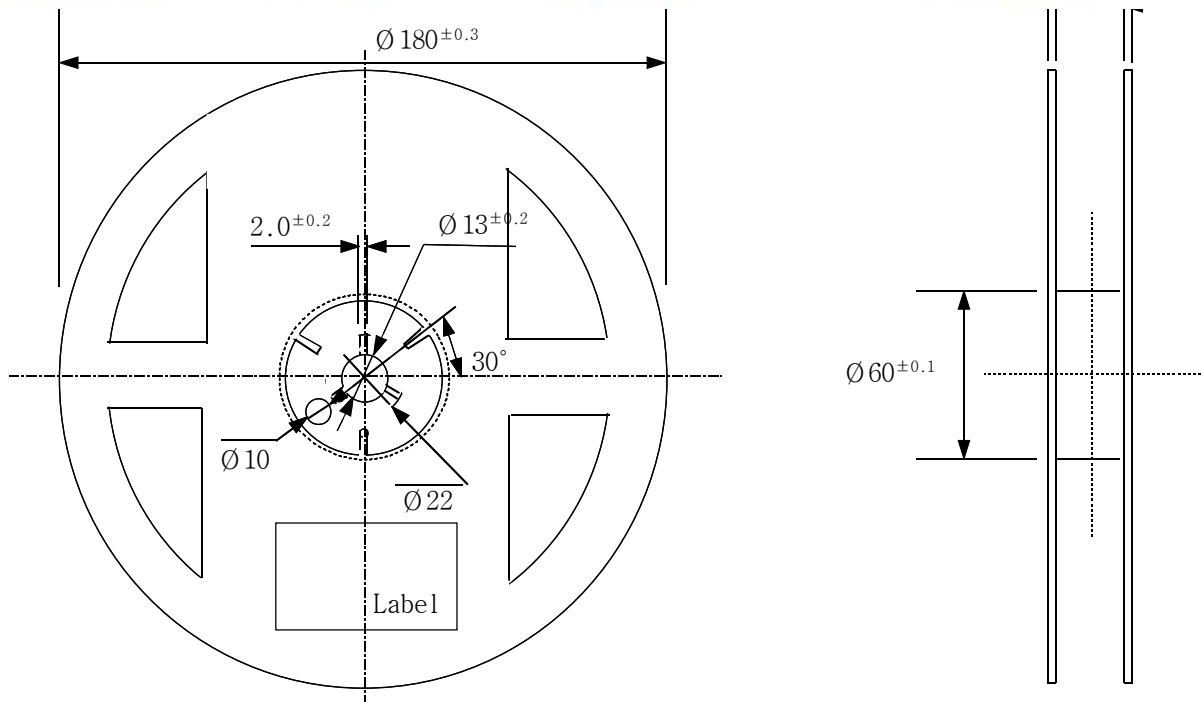
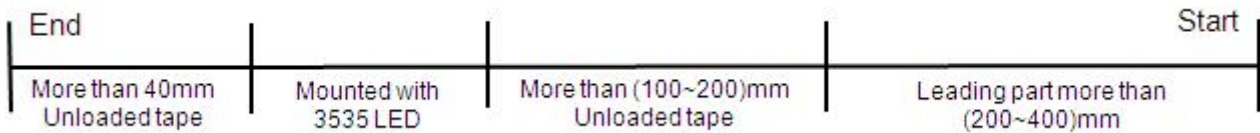
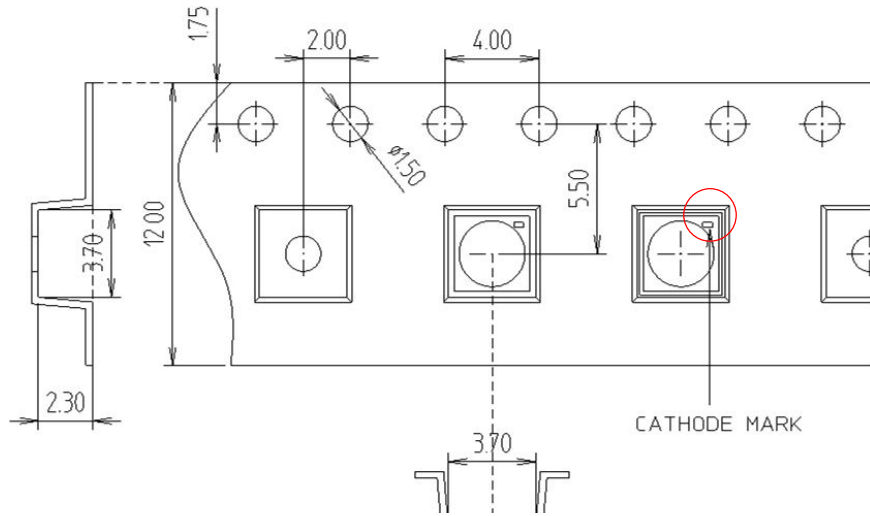

- (1) Quantity : The quantity/reel to be 1,000 pcs.
- (2) Cumulative Tolerance : Cumulative tolerance/10 pitches to be ± 0.2 mm
- (3) Adhesion Strength of Cover Tape : Adhesion strength to be 0.1-0.7N when the cover tape is turned off from the carrier tape at 10° angle to be the carrier tape.
- (4) Packaging : P/N, Manufacturing data code no. and quantity to be indicated on a damp proof package.



8. Label Structure

1) Label Structure

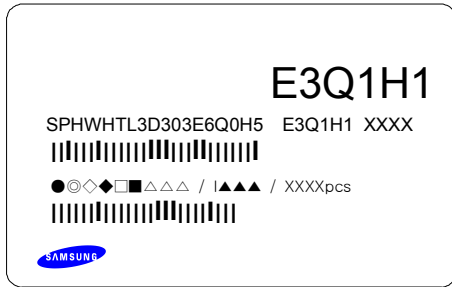

Rank Code

/E3/ : VF Rank

/Q1/ : Color Rank

/H1/ : Flux Bin

2) LOT Number

The Lot number is composed of the following characters

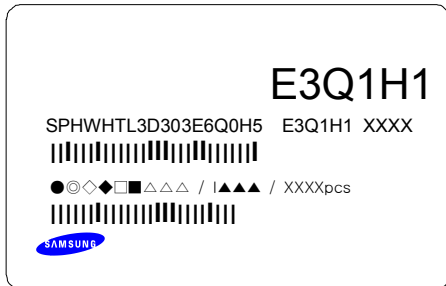

●◎◇◆□■△△△ / |▲▲▲ / 1000PCS

● : Production Site (S:SAMSUNG ELECTRONICS, G:Gosin China)

◎ : L (LED)

◇ : Product State (A:Normality, B:Bulk, C:First Production, R:Reproduction, S:Sample)

◆ : Year (S:2008, T:2009, U:2010...)

□ : Month (1 ~ 9, A, B)

■ : Day (1 ~ 9, A, B ~ V)

△ : SAMSUNG ELECTRONICS Product Number (1 ~ 999)

▲ : Reel Number (1 ~ 999)

2) Aluminum Packing Bag



CAUTION

This bag contains
MOISTURE SENSITIVE DEVICES

LEVEL

2a

1. Shelf life in sealed bag: 12 months at 40°C and 90% relative humidity (RH)
2. Peak package body temperature: 240°C
3. After this bag is opened, devices that will be subjected to reflow solder or other high temperature processes must be:
 - a. Mounted within 672 hours at factory conditions of equal to or less than 30°C / 60% RH, or
 - b. Stored at 10% RH
4. Devices require bake, before mounting, if:
 - a. Humidity Indicator Card is > 65% when read at $23 \pm 5^{\circ}\text{C}$, or
 - b. 2a is not met.
5. If baking is required, devices must be baked for 1 hours at $60 \pm 5^{\circ}\text{C}$

Note: if device containers cannot be subjected to high temperature or shorter bake times are desired, reference IPC/JEDEC J-STD-033 for bake procedure,

Bag seal due date: _____
(if blank, see code label)

Note: Level and body temperature by IPC/JEDEC J-STD-020

E3Q1H1

SPHWHTL3D303E6Q0H5 E3Q1H1 XXXX



●◎◇◆□△△△ / ▲▲▲ / XXXXpcs



SAMSUNG



S3C6810X01-Y540

P/C: S3C6810X01-Y540



LOT: N42KNMC QTY: 2000 U/W: 1201 AS
S3C6810X01-Y540
ASSEMBLED IN KOREA FROM DIE OF KOREA



LEAD-FREE





ATTENTION
OBSERVE PRECAUTIONS
FOR HANDLING
ELECTROSTATIC
SENSITIVE
DEVICES



OTHER

■ 주의 사항

이 알루미늄 지퍼 백은 습기 및 정전기로부터 제품을 보호하기 위하여 제작되었습니다. 개봉 후에는 즉시 솔더 작업을 실시하는 것을 권장합니다.

습기 및 정전기로부터 제품을 보호 하기 위해서 개봉 후 사용하지 않는 자재는 본 팩에 넣어 보관 하시기 바랍니다. 사용하지 않는 자재를 본 팩에 넣을 때는 반드시 동봉된 드라이 팩과 함께 넣고 지퍼부분을 완전하게 밀봉하여 주시기 바랍니다.

■ Important

This Al Zipper bag is designed to protect the enclosed products from moisture and ESD. Once opened, the products should be soldered onto the printed circuit board immediately. When not in use, please do not leave the products unprotected by the Al Zipper Bag. To repack unused products., please ensure the zip-lock is completely sealed with the dry pack left inside.

There are Silica Gel and Humidity Indicator Card in the Aluminum Bag



10. Precaution for use

- 1) For over current-protection, customers are recommended to apply resistors connected in series with the LEDs to mitigate sudden change of the forward current caused by shift of the forward voltage.
- 2) This device should not be used in any type of fluid such as water, oil, organic solvent, etc. When cleaning is required, IPA is recommended as cleaning agent. Solvent-based cleaning agent such as Zestron^(R) may damage the silicone resins used in the device.
- 3) When the device is in operation, the forward current should be carefully determined considering the maximum ambient temperature and the corresponding junction temperature.
- 4) LEDs must be stored in a clean environment. If the LEDs are to be stored for 3 months or more after being shipped from SAMSUNG ELECTRONICS, they should be packed with a nitrogen-filled container.
(Shelf life of sealed bags: 12 months, temp. 0~40°C, 0~90%RH)
- 5) After storage bag is open, device subject to soldering, solder reflow, or other high temperature processes must be:
 - a. Mounted within 672 hours (28 days) at an assembly line with a condition of no more than 30°C/60%RH.
 - b. Stored at <10% RH.
- 6) Repack unused Products with anti-moisture packing, fold to close any opening and then store in a dry place.
- 7) Devices require baking before mounting, if humidity card reading reaches 60% at 23±5°C.
- 8) Devices must be baked for 1hours at 60±5°C, if baking is required.
- 9) The LEDs are sensitive to the static electricity and surge current. It is recommended to use a wrist band or anti-electrostatic glove when handling the LEDs.
If voltage exceeding the absolute maximum rating is applied to LEDs, it may cause damage or even destruction to LED devices.
Damaged LEDs may show some unusual characteristics such as increase in leakage current, lowered turn-on voltage, or abnormal lighting of LEDs at low current.

Test Report No. F690101/LF-CTSAYAA12-09333R1

Issued Date: 2012. 03. 08 Page 2 of 5

Sample No. : AYAA12-09333R1.001
Sample Description : SPHWHTL3D
Item No./Part No. : 3535 Ceramic
Materials : Ceramic, Silicone

Heavy Metals

Test Items	Unit	Test Method	MDL	Results
Cadmium (Cd)	mg/kg	With reference to IEC 62321:2008, ICP	0.5	N.D.
Lead (Pb)	mg/kg	With reference to IEC 62321:2008, ICP	5	N.D.
Mercury (Hg)	mg/kg	With reference to IEC 62321:2008, ICP	2	N.D.
Hexavalent Chromium (Cr VI)	mg/kg	With reference to IEC 62321:2008, UV-VIS	1	N.D.

Flame Retardants-PBBs/PBDEs

Test Items	Unit	Test Method	MDL	Results
Monobromobiphenyl	mg/kg	With reference to IEC 62321:2008, GC-MS	5	N.D.
Dibromobiphenyl	mg/kg	With reference to IEC 62321:2008, GC-MS	5	N.D.
Tribromobiphenyl	mg/kg	With reference to IEC 62321:2008, GC-MS	5	N.D.
Tetrabromobiphenyl	mg/kg	With reference to IEC 62321:2008, GC-MS	5	N.D.
Pentabromobiphenyl	mg/kg	With reference to IEC 62321:2008, GC-MS	5	N.D.
Hexabromobiphenyl	mg/kg	With reference to IEC 62321:2008, GC-MS	5	N.D.
Heptabromobiphenyl	mg/kg	With reference to IEC 62321:2008, GC-MS	5	N.D.
Octabromobiphenyl	mg/kg	With reference to IEC 62321:2008, GC-MS	5	N.D.
Nonabromobiphenyl	mg/kg	With reference to IEC 62321:2008, GC-MS	5	N.D.
Decabromobiphenyl	mg/kg	With reference to IEC 62321:2008, GC-MS	5	N.D.
Monobromodiphenyl ether	mg/kg	With reference to IEC 62321:2008, GC-MS	5	N.D.
Dibromodiphenyl ether	mg/kg	With reference to IEC 62321:2008, GC-MS	5	N.D.
Tribromodiphenyl ether	mg/kg	With reference to IEC 62321:2008, GC-MS	5	N.D.
Tetrabromodiphenyl ether	mg/kg	With reference to IEC 62321:2008, GC-MS	5	N.D.
Pentabromodiphenyl ether	mg/kg	With reference to IEC 62321:2008, GC-MS	5	N.D.
Hexabromodiphenyl ether	mg/kg	With reference to IEC 62321:2008, GC-MS	5	N.D.
Heptabromodiphenyl ether	mg/kg	With reference to IEC 62321:2008, GC-MS	5	N.D.
Octabromodiphenyl ether	mg/kg	With reference to IEC 62321:2008, GC-MS	5	N.D.
Nonabromodiphenyl ether	mg/kg	With reference to IEC 62321:2008, GC-MS	5	N.D.
Decabromodiphenyl ether	mg/kg	With reference to IEC 62321:2008, GC-MS	5	N.D.

NOTE: (1) N.D. = Not detected.(<MDL)
 (2) mg/kg = ppm
 (3) MDL = Method Detection Limit
 (4) - = No regulation
 (5) Negative = Undetectable / Positive = Detectable
 (6) ** = Qualitative analysis (No Unit)
 (7) * = Boiling-water-extraction:
 Negative = Absence of CrVI coating
 Positive = Presence of CrVI coating; the detected concentration in boiling-water-extraction solution is equal or greater than 0.02 mg/kg with 50 cm² sample surface area.

This document is issued by the Company subject to its General Conditions of Service printed overleaf, available at request at www.sgs.com and, for electronic format documents, subject to Terms and Conditions for Electronic Documents at www.sgs.com/sgsweb/guest/sgsweb/guest.htm. Reference is drawn to the limitation of liability, indemnification and jurisdiction issues defined therein. Any holder of this document is advised that information contained herein reflects the Company's findings at the time of its issuance only and within the limits of Client's instructions, if any. The Company's sole responsibility is to its Client and this document does not constitute parties to a transaction, both existing and/or rights and obligations under the transaction documents. This document cannot be reproduced except in full, without prior written approval of the Company's local office or division. Integrity of the content or appearance of this document is subject and a breach may be prosecuted to the fullest extent of the law.

SGS

Test Report No. F690101/LF-CTSAYAA12-09333R1

Issued Date: 2012. 03. 08 Page 3 of 5

Sample No. : AYAA12-09333R1.001
 Sample Description : SPHWHTL3D
 Item No./Part No. : 3535 Ceramic
 Materials : Ceramic,Silicone

Halogen Contents

Test Items	Unit	Test Method	MDL	Results
Bromine(Br)	mg/kg	BS EN 14582:2007 , IC	30	N.D.
Chlorine(Cl)	mg/kg	BS EN 14582:2007 , IC	30	N.D.
Fluorine(F)	mg/kg	BS EN 14582:2007 , IC	30	N.D.
Iodine(I)	mg/kg	BS EN 14582:2007 , IC	50	N.D.

Picture of Sample as Received:

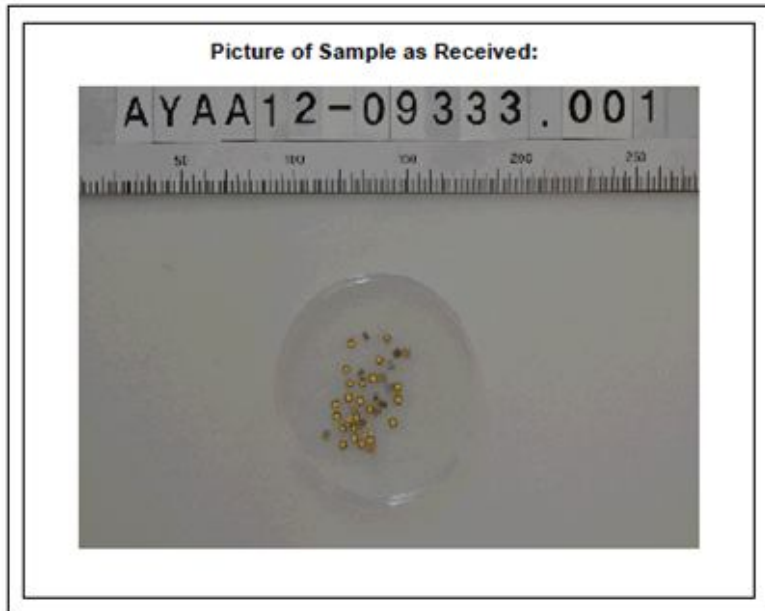

- NOTE: (1) N.D. = Not detected.(<MDL)
 (2) mg/kg = ppm
 (3) MDL = Method Detection Limit
 (4) - = No regulation
 (5) Negative = Undetectable / Positive = Detectable
 (6) ** = Qualitative analysis (No Unit)
 (7) * = Boiling-water-extraction:
 Negative = Absence of CrVI coating
 Positive = Presence of CrVI coating; the detected concentration in boiling-water-extraction solution is equal or greater than 0.02 mg/kg with 50 cm² sample surface area.

This document is issued by the Company subject to its General Conditions of Service (printed document), available on request or accessible at www.sgs.com and, for electronic format documents, subject to Terms and Conditions for Electronic Documents at www.sgs.com. Attention is drawn to the limitation of liability, indemnification and jurisdiction issues defined therein. Any holder of this document is advised that information contained herein reflects the Company's findings at the time of its preparation only and within the limits of Client's instructions. Party to the Company's sole responsibility is to its Client and this document does not constitute parties to a transaction. This warning, of their rights and obligations under the transaction documents. This document cannot be reproduced except in full, without prior written approval of the Company. Unauthorized alteration, forgery or falsification of the content or appearance of this document is unlawful and offenders may be prosecuted to the fullest extent of the law. Unless otherwise stated the results shown in this test report refer only to the samples tested and such samples are retained for 90 days only.

SGS Korea Co., Ltd.

322, The O valley, 555-9, Hoge-dong, Dongan-gu, Anyang-si, Gyeonggi-do, Korea 431-080
 T+82 (0)31 4608 000 T+82 (0)31 4608 059 <http://www.sgsab.co.kr> www.kr.sgs.com/greenlab

F052 Version4

Member of the SGS Group (Société Générale de Surveillance)

<h2>Revision History</h2>

Date	Revision History	Writer	
		Drawn	Approved
2012.08.17	New version	I.J.PYEON	Y.T.KIM
2012.09.24	2nd version	G.E.CHO	Y.T.KIM