

- According to
  - Performance Level (PL) e and category 4 to EN ISO 13849-1: 2008
  - SIL Claimed Level (SIL CL) 3 to IEC/EN 62061
  - Safety Integrity Level (SIL) 3 to IEC/EN 61508
  - Category 4 to EN 954-1
- Output: 3 NO, 1 NC contacts for AC 400 V
- Optionally gold-plated contacts to switch small loads (input for PLC)
- 1-channel or 2-channel connection
- LED displays for channels 1 and 2
- Feedback circuit X3 - X4 for monitoring external contactors
- Removable terminal strips
- Overvoltage and short circuit protection
- Width 100 mm

### Function diagram

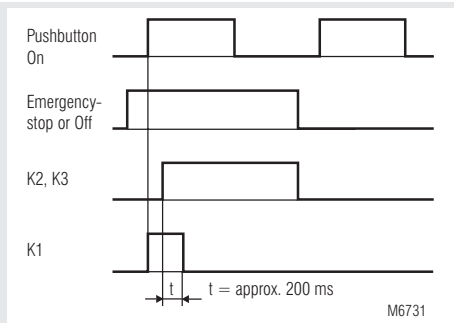

### Approvals and marking



\* see variants

### Application

- Protection of people and machines
- Emergency-stop circuits on machines
  - Monitoring of safety gates

### Block diagram

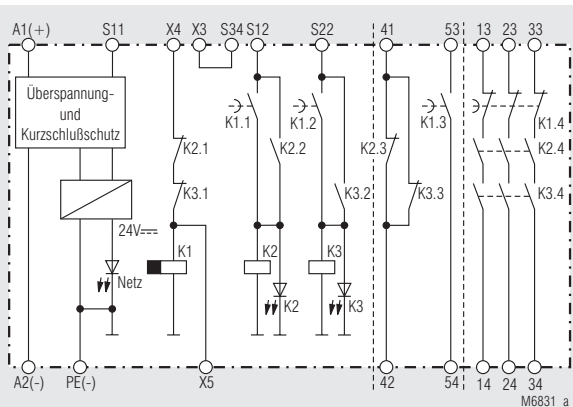

BN 5983.53

### Indication

- LED power supply: on when operating voltage present  
 LED S12 / K2: on when supply on relay K2  
 LED S22 / K3: on when supply on relay K3

### Notes

The PE terminal permits operation of the device in IT systems with insulation monitoring and also serves as a reference point for testing the control voltage. The internal short-circuit protection will be bridged on DC devices, if the protective ground is connected to terminal PE. One or more extension modules BN 3081 or external contactors with forcibly guided contacts may be used to multiply the number of contacts of the emergency-stop module BN 5983.

### ATTENTION - AUTOMATIC START!

According to IEC/EN 60 204-1 part 9.2.5.4.2 it is not allowed to restart automatically after emergency stop. Therefore the machine control has to disable the automatic start after emergency stop.



### Circuit diagram

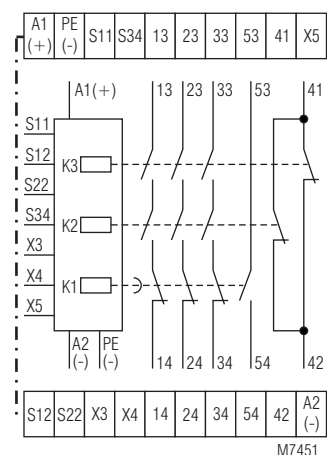

BN 5983.53, \_/104, \_/110, \_/200

**Technical Data****Input**

<b>Nominal voltage <math>U_N</math>:</b>	AC 24, 42, 48, 110, 127, 230, 240 V DC 24, 48, 110 V
<b>Voltage range:</b>	AC 0.8 ... 1.1 $U_N$
at 10 % residual ripple:	DC 0.9 ... 1.2 $U_N$
at 48 % residual ripple:	DC 0.8 ... 1.1 $U_N$
<b>Nominal consumption:</b>	5 VA $\pm$ 30 %
<b>Nominal frequency:</b>	50 / 60 Hz
<b>Control voltage S11:</b>	DC 24 V
<b>Control current:</b>	max. DC 100 mA
<b>Minimum voltage at terminals S12, S22:</b>	DC 21 V with activated device

**Output****Contacts**

BN 5983.53:	3 NO, 1 NC contacts 1 delay-release NO contact (K1.3) The NO contacts 13...33 / 14...34 are safety contacts. <b>ATTENTION! The NC contact 41-42 and the NO contact 53-54 can only be used for monitoring.</b> 35 ms
-------------	---

**Operate time:****Release time**

opening in secondary circuit

(S12-S22): 30 ms  $\pm$  25 %opening in supply circuit: 100 ms  $\pm$  50 %**Release delay of K1:** approx. 200 ms**Contact type:** Relay, forcibly guided**Nominal output voltage:** AC 400 V / DC 230 V**Thermal current  $I_{th}$ :** see continuous current limit curve (max. 10 A in one contact path)**Switching capacity**

to AC 15: 5 A / AC 230 V IEC/EN 60 947-5-1

for NO contacts

2 A / AC 230 V IEC/EN 60 947-5-1

for NC contacts

to DC 13: 4 A / DC 24 V IEC/EN 60 947-5-1

for NO contacts

4 A / DC 24 V IEC/EN 60 947-5-1

for NC contacts

to DC 13

NO contacts: 10 A / 24 V > 10<sup>5</sup>  
ON: 0.4 s, OFF: 9.6 s**Electrical life**to AC 15 at 2 A, AC 230 V: 10<sup>5</sup> switching cycles IEC/EN 60 947-5-1to DC 13 at 2 A, DC 24 V: > 240 x 10<sup>3</sup> switching cycles**Permissible operating frequency:**

6 000 switching cycles / h

**Short circuit strength**

max. fuse rating: 10 A gL IEC/EN 60 947-5-1

max. line circuit breaker: C 10 A

**Mechanical life:**10 x 10<sup>6</sup> switching cycles**General Data****Operating mode:**

Continuous operation

**Temperature range**

operation:

- 15 ... + 55 °C

at max. 90 % humidity

storage :

- 25 ... + 85 °C

**altitude:**

&lt; 2.000 m

**Clearance and creepage distances**

rated impuls voltage /

pollution degree: 4 kV / 2 (basis insulation) IEC 60 664-1

**EMC**

Electrostatic discharge: 8 kV (air) IEC/EN 61 000-4-2

HF irradiation: 10 V / m IEC/EN 61 000-4-3

Fast transients: 2 kV IEC/EN 61 000-4-4

Surge voltages

between

wires for power supply: 1 kV IEC/EN 61 000-4-5

between wire and ground: 4 kV IEC/EN 61 000-4-5

Interference suppression: Limit value class B EN 55 011

**Technical Data****Degree of protection**

Housing: IP 40 IEC/EN 60 529

Terminals: IP 20 IEC/EN 60 529

**Housing:** Thermoplastic with V0 behaviour according to UL subject 94**Vibration resistance:** Amplitude 0.35 mm IEC/EN 60 068-2-6  
frequency: 10 ... 55 Hz**Climate resistance:** 15 / 055 / 04 IEC/EN 60 068-1**Terminal designation:** EN 50 005**Wire connection:** 2 x 2.5 mm<sup>2</sup> solid or  
2 x 1.5 mm<sup>2</sup> stranded ferruled  
DIN 46 228-1/-2/-3/-4**Wire fixing:** Flat terminals with self-lifting  
clamping piece IEC/EN 60 999-1  
Removable terminal strip**Mounting:** DIN rail IEC/EN 60 715**Weight:** 840 g**Dimensions****Width x height x depth:** 100 x 74 x 121 mm**Safety related data****Values according to EN ISO 13849-1:**

Category:	4	
PL:	e	
MTTF <sub>d</sub> :	236.1	a
DC / DC <sub>avg</sub> :	97.2	%
d <sub>op</sub> :	365	d/a (days/year)
h <sub>op</sub> :	24	h/d (hours/day)
t <sub>cycle</sub> :	3600	s/cycle
	$\geq$ 1	/h (hour)

**Values according to IEC/EN 62061 / IEC/EN 61508:**

SIL CL:	3	IEC/EN 62061
SIL	3	IEC/EN 61508
HFT:	1	
DC / DC <sub>avg</sub> :	97.2	%
SFF	99.8	%
PFH <sub>D</sub> :	2.05E-10	h <sup>-1</sup>

\*) HFT = Hardware-Failure Tolerance



The values stated above are valid for the standard type.

Safety data for other variants are available on request.

The safety relevant data of the complete system has to be determined by the manufacturer of the system.

**Standard type**

BN 5983.53 DC 24 V		
Article number:	0032155	stock item
• Output:	3 NO, 1 NC contacts	
• Nominal voltage $U_N$ :	DC 24 V	
• Width:	100 mm	

## Variants

**BN 5983.53/60:** with CSA approval

**BN 5983.53/61:** with UL approval (Canada/USA)

**BN 5983.53/104:**

For switching small loads of 1 mVA ... 7 VA or 1 mW ... 7 W in the ranges 0.1 ... 60 V and 1 ... 300 mA.

The device is also suitable for switching the maximum switching current. However, this will burn off the gold plating of the contacts, so that switching of small loads is no longer possible afterwards.

**BN 5983.53/110:**

To avoid latching problems in the case of short voltage drops K2 and K3 are switched definitely off before reset.

**BN 5983.53/200:**

Redundant switching off with device diversity. Device diversity means that safety relays from different production batches or from different manufacturers are used.

## Ordering example for Variants

BN 5983 .53 / \_ \_ \_ AC 230 V 50/60 Hz

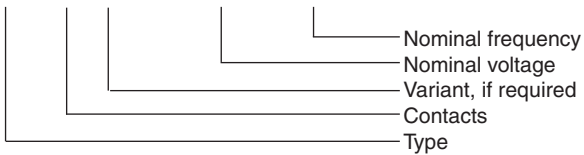

## Characteristics

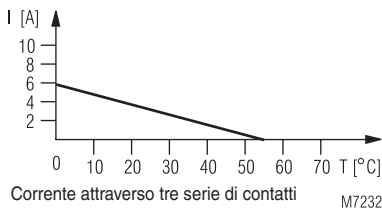
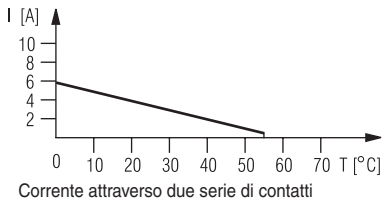
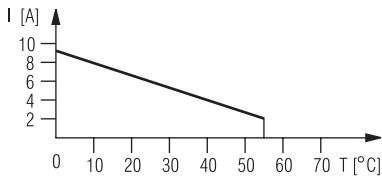

Continuous current limit curves  
as a function of ambient temperature

## Characteristics

electric life DC13 24V DC /  $t_{on}$  0,4s;  $t_{off}$  9,6s

2 contacts in series

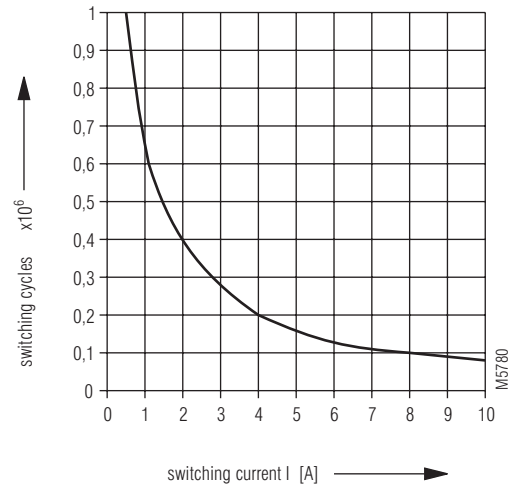

Contact service life

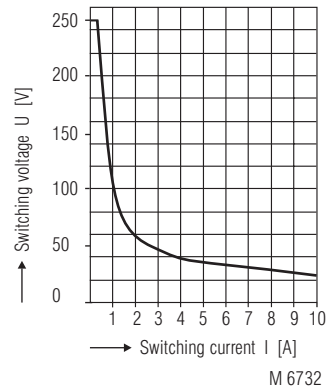

Limit curve for arc-free  
operation with resistive load

## Application examples

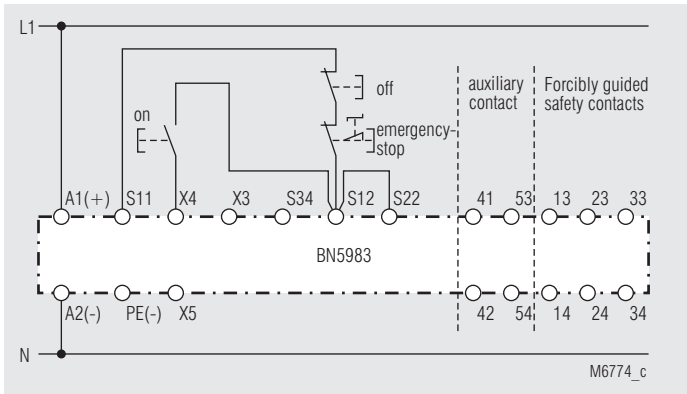

One-channel emergency-stop circuit. This circuit does not have any redundancy in the emergency-stop control circuit

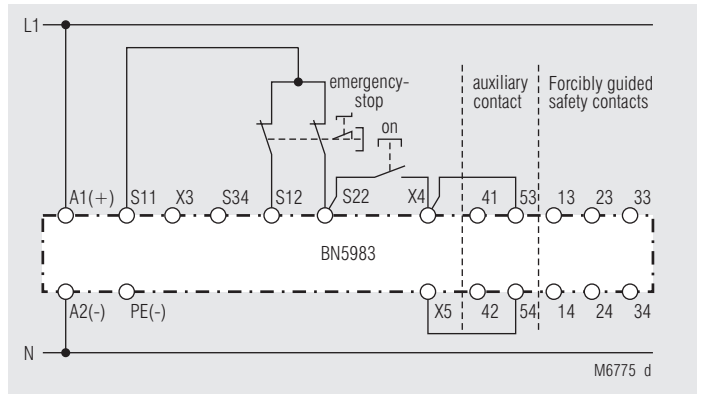

Two-channel emergency stop circuit with line fault detection on start button. The unit starts with the negative edge of the start signal (contrary to the function diagram).  
If line fault detection is not necessary the links X4-53 and X5-54 can be removed.

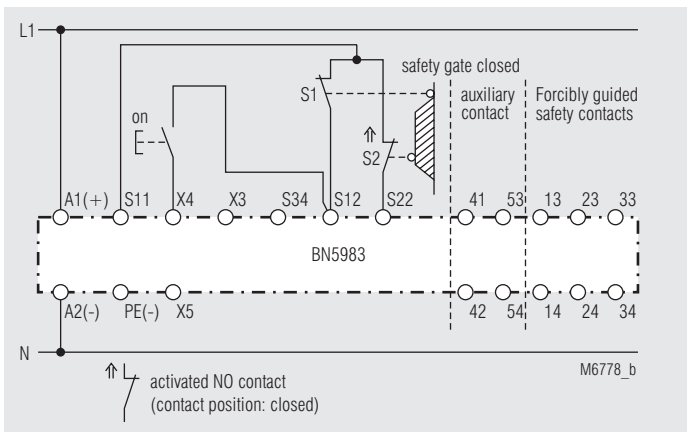

Two-channel monitoring of a safety gate

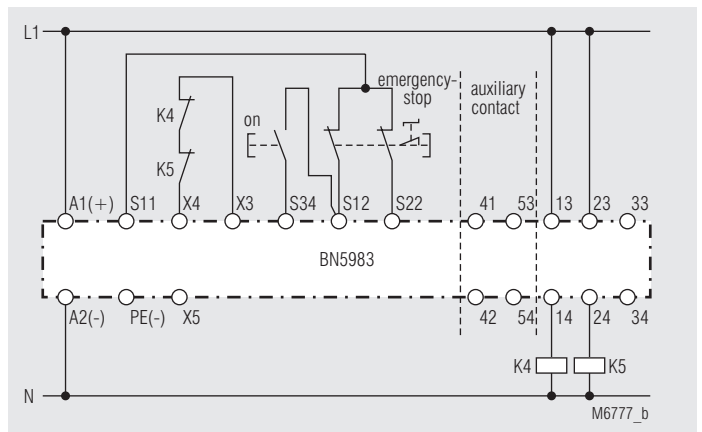

Contact reinforcement by external contactors, 2-channel.

The output contacts can be reinforced by external contactors with forcibly guided contacts for switching currents > 10 A. Functioning of the external contactors is monitored by looping the NC contacts into the closing circuit (terminals X3 - X4).

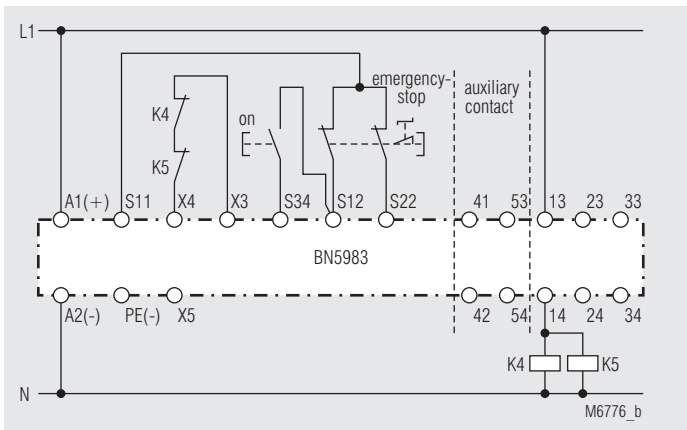

Contact reinforcement by external contactors with reduced safety level

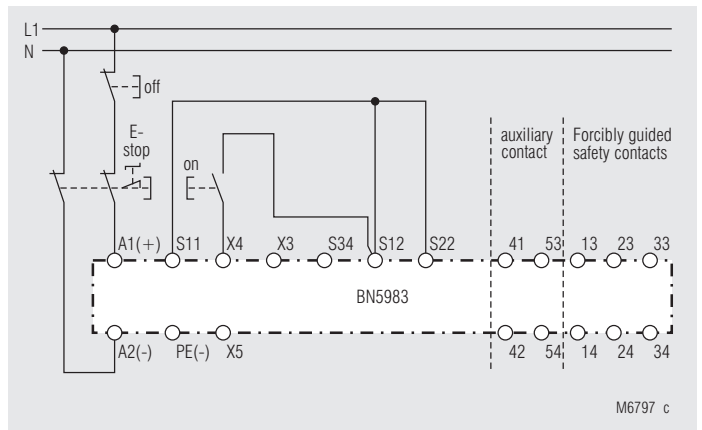

Picture M 6797:

Two-pole emergency-stop circuit with emergency stop control device in supply circuit.

Application for long emergency stop loops where the control voltage drops below the minimum voltage of 21 V.

### Attention:

Single faults (e.g. line faults at the emergency stop control device) are not detected with this external circuit configuration