

Spherical roller bearings, cylindrical and tapered bore

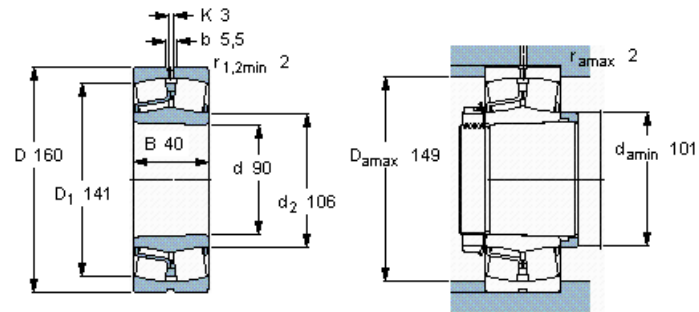

Principal dimensions			Basic load ratings		Fatigue load limit P_u	Speed ratings		Mass	Designation
d	D	B	dynamic	static		Reference speed	Limiting speed		
mm			C	C_0	kN	r/min	kg	-	* - SKF Explorer bearing
90	160	40	325	375	39	3800	3,35	22218 EK *	



Tapered bore, taper
1: 12

Calculation factors

- e 0,24
- Y_1 2,8
- Y_2 4,2
- Y_0 2,8