

PFT 12 TF

Housing material

Pressed steel

Dimensions

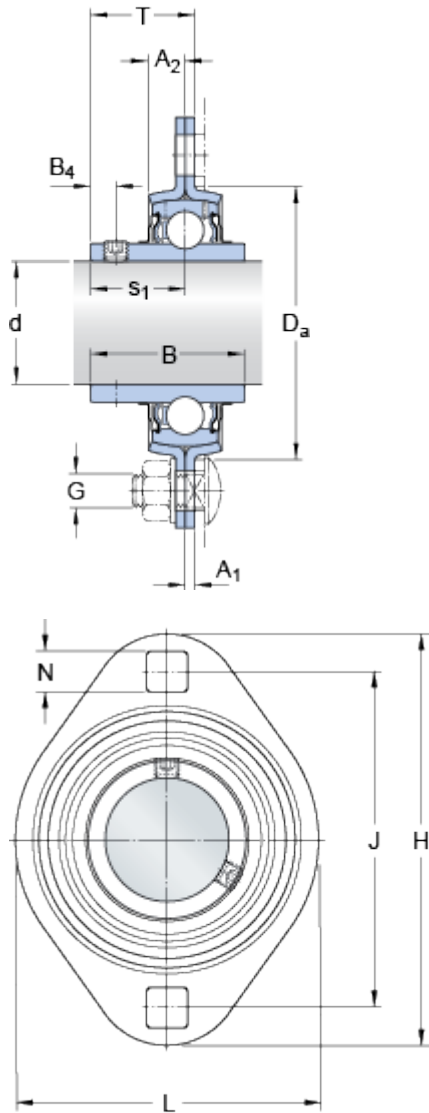

d		12	mm
A ₁		2	mm
A ₂		7	mm
B		27.4	mm
B ₄		4	mm
D _a	min.	44	mm
J		63	mm
H		81	mm
L		59	mm
N		7.1	mm
s ₁		15.9	mm
T		17.9	mm

Dowel pins

Grease fitting

Threaded hole

Calculation data

Basic dynamic load rating	C	9.6	kN
Basic static load rating	C ₀	4.8	kN
Fatigue load limit	P _u	0.2	kN
Limiting speed		9500	r/min

(with shaft tolerance h6)

Mass

Mass bearing unit	0.19	kg
-------------------	------	----

Mounting information

Thread grub screw	G 2	M6x0.75	
Hexagonal key size for grub screw	N	3	mm
Recommended tightening torque for grub screw		4	N·m
Recommended diameter for attachment bolts, mm	G	6	mm
Recommended diameter for attachment bolts, inch	G	0.25	in

Appertaining products

Housing	PFT 40
Bearing	YAR 203/12-2F