



# Operator's Manual

## WaveStation Function/Arbitrary Waveform Generator



# LeCroy

## WaveStation



Function/Arbitrary Waveform Generator

March, 2012



## LeCroy Corporation

700 Chestnut Ridge Road  
Chestnut Ridge, NY, 10977-6499  
Tel: (845) 578-6020, Fax: (845) 578 5985

## Warranty

**NOTE:** THE WARRANTY BELOW REPLACES ALL OTHER WARRANTIES, EXPRESSED OR IMPLIED, INCLUDING BUT NOT LIMITED TO ANY IMPLIED WARRANTY OF MERCHANTABILITY, FITNESS, OR ADEQUACY FOR ANY PARTICULAR PURPOSE OR USE. LECROY SHALL NOT BE LIABLE FOR ANY SPECIAL, INCIDENTAL, OR CONSEQUENTIAL DAMAGES, WHETHER IN CONTRACT OR OTHERWISE. THE CUSTOMER IS RESPONSIBLE FOR THE TRANSPORTATION AND INSURANCE CHARGES FOR THE RETURN OF PRODUCTS TO THE SERVICE FACILITY. LECROY WILL RETURN ALL PRODUCTS UNDER WARRANTY WITH TRANSPORT PREPAID.

The instrument is warranted for normal use and operation, within specifications, for a period of one year from shipment. LeCroy will either repair or, at our option, replace any product returned to one of our authorized service centers within this period. However, in order to do this we must first examine the product and find that it is defective due to workmanship or materials and not due to misuse, neglect, accident, or abnormal conditions or operation.

LeCroy shall not be responsible for any defect, damage, or failure caused by any of the following: a) attempted repairs or installations by personnel other than LeCroy representatives or b) improper connection to incompatible equipment, or c) for any damage or malfunction caused by the use of non-LeCroy supplies. Furthermore, LeCroy shall not be obligated to service a product that has been modified or integrated where the modification or integration increases the task duration or difficulty of servicing the instrument. Spare and replacement parts, and repairs, all have a 90-day warranty.

The instrument firmware has been thoroughly tested and is presumed to be functional. Nevertheless, it is supplied without warranty of any kind covering detailed performance. Products not made by LeCroy are covered solely by the warranty of the original equipment manufacturer.

**Internet:** [www.lecroy.com](http://www.lecroy.com)

© 2012 by LeCroy Corporation. All rights reserved.

Unauthorized duplication of LeCroy documentation materials other than for internal sales and distribution purposes is strictly prohibited. However, clients are encouraged to distribute and duplicate LeCroy documentation for their own internal educational purposes.

LeCroy and other product or brand names are trademarks or requested trademarks of their respective holders. Information in this publication supersedes all earlier versions. Specifications are subject to change without notice.

|  |   |   |
|--|---|---|
| <p>Manufactured under an ISO 9000 Registered Quality Management System.</p> <p>Visit <a href="http://www.lecroy.com">www.lecroy.com</a> to view the certificate.</p> |  | <p>This electronic product is subject to disposal and recycling regulations that vary by country and region. Many countries prohibit the disposal of waste electronic equipment in standard waste receptacles.</p> <p>For more information about proper disposal and recycling of your LeCroy product, please visit <a href="http://www.lecroy.com/recycle">www.lecroy.com/recycle</a>.</p> |
|--|---|---|

WSta-OM-E RevA

920551-00 RevA



## TABLE OF CONTENTS

|  |           |
|--|-----------|
| <b>Welcome .....</b>                                 | <b>6</b>  |
| Contact LeCroy for Support .....                     | 6         |
| Thank You .....                                      | 7         |
| <b>Package Contents.....</b>                         | <b>8</b>  |
| <b>Safety Requirements.....</b>                      | <b>8</b>  |
| Safety Symbols.....                                  | 8         |
| Operating Environment .....                          | 10        |
| Cooling .....  | 11        |
| AC Power Source.....                                 | 11        |
| Power Consumption .....                              | 11        |
| Calibration.....                                     | 11        |
| Cleaning .....                                       | 11        |
| Abnormal Conditions .....                            | 11        |
| <b>Hardware and I/O .....</b>                        | <b>12</b> |
| Adjusting the Handle .....                           | 12        |
| Front Panel.....                                     | 13        |
| Back Panel.....                                      | 14        |
| <b>Getting Started with WaveStation .....</b>        | <b>15</b> |
| The WaveStation Interface .....                      | 15        |
| Waveform Types and Default Parameters .....          | 21        |
| Initial Function Settings .....                      | 22        |
| Waveform Signal Conditioning Buttons .....           | 22        |
| Save/Recall, Utility, and Help Buttons .....         | 23        |
| Main Waveform Buttons .....                          | 23        |
| Waveform Signal Conditioning Function Buttons .....  | 23        |
| Save/Recall, Utility, and Help Function Buttons..... | 24        |
| Digital Input Front Panel Controls .....             | 27        |

# WaveStation

---

- Creating Waveforms ..... 27**
  - Creating Waveforms Overview .....27
  - Creating a Sine Wave .....28
    - Frequency/Period.....28
    - Amplitude/HLevel .....29
    - Offset/LLevel .....30
    - Phase/EqPhase.....31
  - Creating a Square Wave.....31
  - Duty Cycle .....32
  - Creating a Ramp Wave.....33
  - Symmetry .....34
  - Creating a Pulse Wave .....34
    - PulWidth/Duty .....35
    - Delay.....36
  - Creating a Noise Wave .....36
    - Variance/Mean .....37
  - Creating an Arbitrary Waveform.....37
    - Load Wform .....38
- Generating Modulated Waveforms ..... 41**
- Generating Sweep Waveforms ..... 47**
- Generating Burst Waveforms ..... 51**
- Save/Recall ..... 56**
  - Save/Recall Overview.....56
  - Main Save/Recall Operations.....57
  - Operation Menu Selections and Parameters.....58
- Utility ..... 62**
  - Utility Overview.....62
  - Main Utility Operations.....62
  - Common Util Menu Controls and Considerations .....62

|  |           |
|--|-----------|
| Utility Operation Menu Selections and Parameters....         | 63        |
| Restoring the Default Settings.....                          | 73        |
| <b>Using WaveStation Help.....</b>                           | <b>75</b> |
| <b>Controlling WaveStation with USB-GPIB and/or USBTMC76</b> |           |
| The USB-GPIB Adapter.....                                    | 76        |
| Connecting Your Adapter .....                                | 77        |
| <b>WaveStation PC Software.....</b>                          | <b>78</b> |
| WaveStation PC Software Overview.....                        | 78        |
| Installing the WaveStation PC Drivers and Software...        | 79        |
| Making the WaveStation - PC Software Connection ...          | 80        |
| <b>Reference .....</b>                                       | <b>89</b> |
| Specifications .....   | 89        |
| CERTIFICATIONS.....  | 89        |
| CE Declaration of Conformity .....                           | 89        |
| China RoHS Compliance.....                                   | 91        |
| China RoHS Compliance (English Version).....                 | 92        |
| Contact LeCroy for Support .....                             | 93        |
| <b>Index .....</b>   | <b>96</b> |

# WaveStation

---

## Welcome

Thank you for purchasing a LeCroy WaveStation.

The WaveStation is a function/arbitrary waveform generator that allows you to customize settings on waveforms you create while seeing them graphically at the same time.

**Controlling WaveStation with USB-GPIB and/or USBTMC** (on page 76) is possible, and you can even transfer waveforms to and from your WaveStation using the WaveStation PC Software. See **WaveStation PC Software Overview** (on page 78).

This WaveStation Operator's Manual covers how to use the following models and their system requirements:

- WaveStation **2012 10 MHz**
- WaveStation **2022 25 MHz**
- WaveStation **2052 50 MHz**

This material is organized in the following manner:

1. Package Contents and Safety Requirements are first provided along with the Hardware and I/O Section familiarize you with the WaveStation hardware.
2. The Getting Started with WaveStation section provides explanations of the interface and a general overview of the standard controls on the front panel and how they correspond with the screen displays.
3. Sections then provide more detail covering the creation of Waveform Types, Modulated Waveforms, Sweep Waveforms, and Burst Waveforms. Additional sections explain how to use Save/Recall, Utility, and Help sections.
4. Another section explains how to Control WaveStation with USB-GPIB (using the The USB-GPIB Adapter) and/or USBTMC.
5. As previously mentioned, we then show you how to use the WaveStation Software to send and receive waveforms over a PC connection with your WaveStation.
6. Finally a Reference section is provided for details on where to find regularly updated Specifications and other details.

## Contact LeCroy for Support

When your WaveStation is delivered, verify that all items on the packing list or invoice copy have shipped correctly. Contact your nearest LeCroy customer service center or national distributor if anything is missing or damaged. If you do not contact us immediately, we cannot be responsible for replacement. If you have any problems with your product, please **Contact LeCroy for Support** (on page 93).

## Thank You

We truly hope these materials provide increased comprehension when using LeCroy's fine products.

Sincerely,

A handwritten signature in black ink, reading "David C. Graef". The signature is fluid and cursive, with a long, sweeping underline that extends to the right.

**David C. Graef**

LeCroy Corporation

*Vice President and Chief Technology Officer*

# Package Contents

The standard WaveStation package includes the following:

- WaveStation Function/Arbitrary Waveform Generator
- Power Cord
- Standard USB 2.0 Type A to Type B Cable, 1 m
- USB to GPIB Converter Cable
- WaveStation Operator's Manual
- Performance/Calibration Certificate
- Installation CD containing the WaveStation PC Software
- Product Registration Card

# Safety Requirements

This section contains information and warnings that must be observed to keep the instrument operating in a correct and safe condition. You are required to follow generally accepted safety procedures in addition to the safety precautions specified in this section.

## Safety Symbols

Where the following symbols appear on the instrument's front or rear panels, or in this manual, they alert you to important safety considerations.



This symbol is used where caution is required. Refer to the accompanying information or documents in order to protect against personal injury or damage to the instrument.

---



This symbol warns of a potential risk of shock hazard.

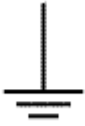

This symbol is used to denote the measurement ground connection.

---

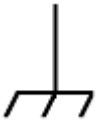

This symbol is used to denote a frame or chassis connection.

---



This symbol is used to denote a safety ground connection.

---



This symbol is used to denote Power. It is located on the front panel and denotes Power On/Off status of the instrument.

---

### **CAUTION**

The **CAUTION** sign indicates a potential hazard. It calls attention to a procedure, practice or condition which, if not followed, could possibly cause damage to equipment. If a **CAUTION** is indicated, do not proceed until its conditions are fully understood and met.

---

### **WARNING**

The **WARNING** sign indicates a potential hazard. It calls attention to a procedure, practice or condition which, if not followed, could possibly cause bodily injury or death. If a **WARNING** is indicated, do not proceed until its conditions are fully understood and met.

---

# WaveStation

---

## CAT I

Installation (Overvoltage) Category rating per EN 61010-1 safety standard and is applicable for the instrument front panel measuring terminals. CAT I rated terminals must only be connected to source circuits in which measures are taken to limit transient voltages to an appropriately low level.

## Operating Environment

The instrument is intended for indoor use and should be operated in a clean, dry environment. Before using this product, ensure that its operating environment is maintained within these parameters:

**Temperature:** 0 °C to 40 °C

**Humidity:** Maximum relative humidity 80% (non-condensing) for temperatures up to 30 °C decreasing linearly to 50 % relative humidity at 40 °C.

**Altitude:** Up to 10,000 ft (3,048 m) at or below 30 °C.

**Note:** Direct sunlight, radiators, and other heat sources should be taken into account when assessing the ambient temperature.



### WARNING

The instrument must not be operated in explosive, dusty, or wet atmospheres.

---



### CAUTION

Do not exceed the maximum specified front panel terminal voltage levels. Refer to Specifications for more details.

## Cooling

The instrument relies on forced air cooling with an internal fan and ventilation openings. Care must be taken to avoid restricting the airflow around the apertures (fan holes) at the side of the instrument.



### CAUTION

Do not allow any foreign matter to enter the instrument through the ventilation holes, etc.

## AC Power Source

100-240 VAC ( $\pm 10\%$ ) at 50/60 Hz ( $\pm 5\%$ ) or 100-120 VAC at 400 Hz ( $\pm 5\%$ )

Automatic AC voltage selection

No manual voltage selection is required because the instrument automatically adapts to line voltage.

## Power Consumption

50 VA (50 W) Max



### WARNING - Electrical Shock Hazard

Only use the power cord provided with your instrument.

---

## Calibration

The recommended calibration interval is one year. Calibration should be performed by qualified personnel only.

## Cleaning

Clean only the exterior of the instrument, using a damp, soft cloth. Do not use chemicals or abrasive elements. Under no circumstances allow moisture to penetrate the instrument.

## Abnormal Conditions

Operate the instrument only as intended by the manufacturer.

---

## WaveStation

---

If you suspect the instrument's protection has been impaired, disconnect the power cord and secure the instrument against any unintended operation.

The instrument's protection is likely to be impaired if, for example, the instrument shows visible damage or has been subjected to severe transport stresses.

Proper use of the instrument depends on careful reading of all instructions and labels.



### WARNING

Any use of the instrument in a manner not specified by the manufacturer may impair the instrument's safety protection.

## Hardware and I/O

### Adjusting the Handle

The construction of the handle on your WaveStation can be adjusted to bridge the front panel and fully-support the weight of the generator during transport.

**Note:** Adjust the while gently pulling outward on the two arms where they attach to the sides of your WaveStation.

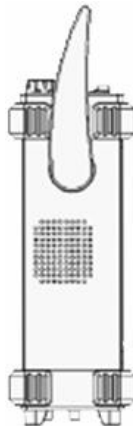

You can also move the handle into a tucked position under the generator for different viewing positions.

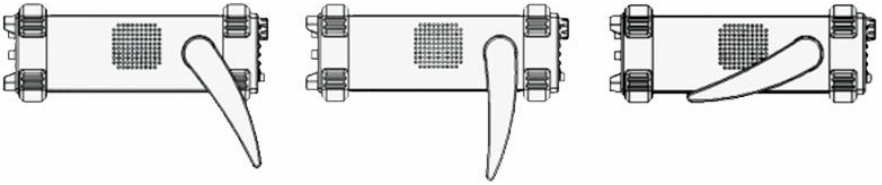

## Front Panel

Numbered callouts on this image correspond with the following descriptions.



1. **Power Button**
2. **USB Connector** - USB 2.0 connector which is used for making **USB-GPIB** or **Memory Stick** connections as explained in **Controlling WaveStation with USB-GPIB and/or USBTMC** (on page 76) and **Main Save/Recall Operations** (on page 57), respectively.
3. **LCD Display**
4. **Display Menu Operation Buttons**
5. **Waveform Buttons** - These buttons control the selection of **Waveform Types and Default Parameters** (on page 21).
6. **Number Buttons**
7. **Function Buttons** - When pressed, these buttons setup corresponding **Initial Function Settings** (on page 22).

## WaveStation

Specifically, the top three buttons are **Waveform Signal Conditioning** buttons and apply **Mod**, **Sweep**, or **Burst** functions to the waveform you've selected. Meanwhile, the lower three, **Save/Recall**, **Utility**, and **Help**, are for various WaveStation tools and configurations along with some Help information.

8. **BNC Channel Outputs and Corresponding Control Buttons** - The buttons above the BNC connectors control the activation/deactivation of corresponding channel outputs.
9. **Direction Buttons**
10. **Adjustment Control Knob**

**Note:** When using WaveStation (or any signal generator) it's important to understand the relationship between the **Main Waveform Type** buttons, the **Waveform Signal Conditioning** function buttons, and the **Save/Recall**, **Utility**, and **Help** function buttons. See **Combined Use of Waveform, Function, and Configuration Buttons** (on page 23).

## Back Panel

Numbered callouts on this image correspond with the following descriptions.

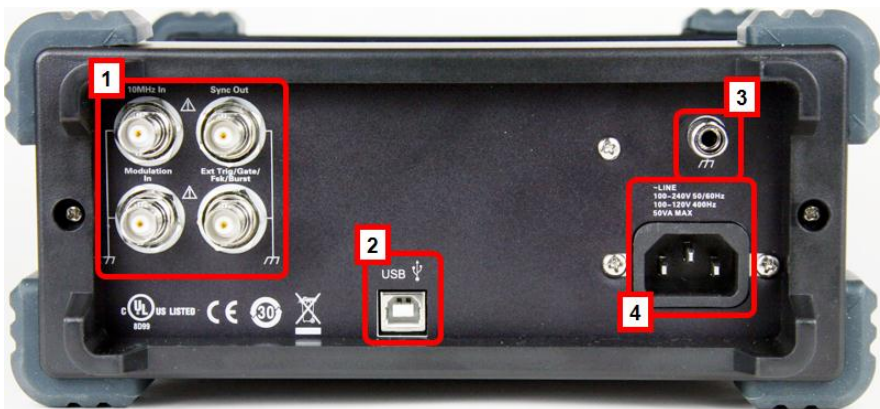

1. **Input and Output BNC Connectors** - Four BNC Connectors provide **10 MHz In**, **Modulation In**, **Synch Out**, **Ext Trig/Gate/Fsk/Burst Out**.

2. **USB Connector** - USB 2.0 connector which is used for making **USBRAW** or **USBTMC** connections as explained in **WaveStation PC Software Overview** (on page 78) and **Controlling WaveStation with USB-GPIB and/or USBTMC** (on page 76), respectively.
3. **Ground Connector**
4. **AC Power Connector**

## Getting Started with WaveStation

### The WaveStation Interface

Numbered callouts on this image of the WaveStation interface correspond with the following descriptions.

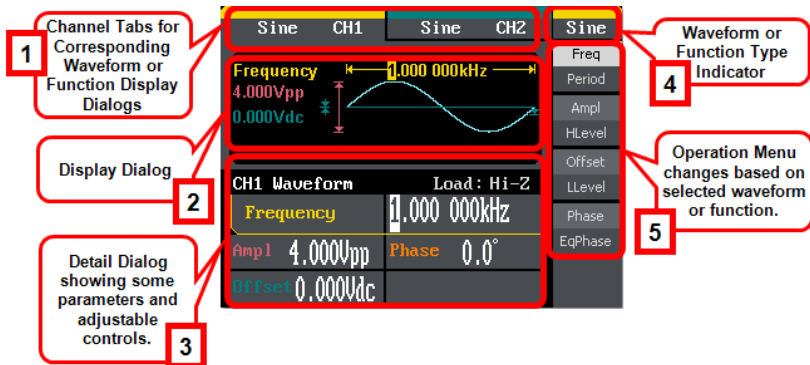

**Note:** The default signal is a **Sine** wave as each channel tab and in the upper-right corner of the display show.

1. **Channel Tabs** - The channel tabs display the currently chosen **Waveform** or **Function** type and, when selected, show their corresponding **Display** and **Detail** dialog.
2. **Display Dialog** - Shows a rendered waveform or modulated waveform display of your generated signal and some additional waveform details .
3. **Detail Dialog** - Shows even more data regarding specific parameters for your selected Waveform or Function.
4. **Waveform/Function Type Indicator** - When using the **Waveform** buttons, shows the waveform type for the corresponding waveform channel selected.

## WaveStation

---

Waveform types include **Sine**, **Square**, **Ramp**, **Pulse**, **Noise**, and **Arb**. When using the **Function** buttons, shows the selected function from **Modulate**, **Sweep**, **Burst**, **Save/Recall**, **Utility**, and **Help**.

5. **Operation Menu** - This menu changes based on the selected **Waveform** or **Function** chosen. Refer to more detailed corresponding coverage later in this manual for more information.

## Navigating Interfaces, Adjusting Parameters, and Making Selections

Specific waveform types may be used as carrier waveforms for specific functions as explained in **Initial Function Settings** (on page 22).

**Note:** Default values for most modulated waveform parameters may be set using certain options available from the Utility menu. Learn more in **Main Utility Operations** (on page 62).

Subsequent sections go into more detail when using specific **Waveform** and **Function** buttons and adjusting specific parameters - all of which vary based on the specific waveform, function, and/or carrier waveform selections made. This particular topic covers some common navigation, parameter adjustments, and making selections when using the WaveStation interfaces.

1. Typically, the first step when using interfaces is to make specific **Waveform** or **Function** button selections on the **Front Panel** (on page 13) in order to make specific parameter adjustments or other selections.

**Note:** If you've selected a Function button, you now choose a desired carrier waveform type using the **Display Menu Operation** buttons. The waveform is shown on the **Waveform Display**.

- At this point, the **Display Menu Operation** buttons are used to select applicable parameters and make adjustments as desired. The operation menu's currently selected parameter is shown in white.



Ampl Parameter is white because it's selected.  
(first press shared parameter for this button)

HLevel Parameter is dark and not selected.  
(second press shared parameter for this button)

While navigating, you'll come across the following interfaces and button type combinations.

- First/Second Press Shared Buttons** - A good portion of the operation buttons control two separate parameters. Operation buttons controlling two parameters have additional, lighter shaded control labels on them; press the button **once to adjust the top control parameter; twice to adjust the bottom one**. Second operation button press parameters are shown in reverse color on some interface dialogs to provide a visual indication as to which parameter is being adjusted.

## WaveStation

- **Parameter Label and Selection Display Button** - However, some parameters look like they're first/second press shared buttons, and really are not. Instead, the parameter title is shown in the top portion and the lower portion displays the particular parameter selection as the following **Shape** parameter shows.

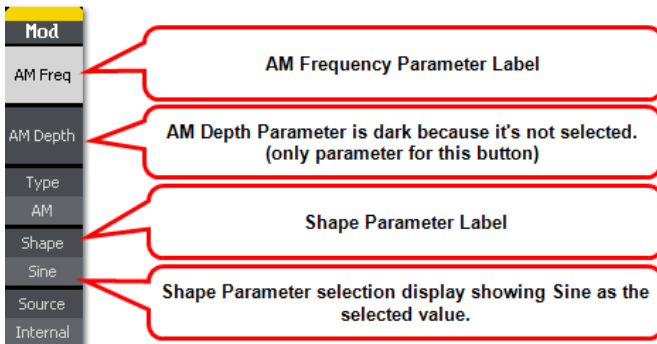

- **Additional Menus** - Operation menus containing more parameters than the ones showing on the first menu have a **1/X ↓** final selection. The additional menu(s) therefore have a **2/X ↑** first selection. Press the adjacent operation button to navigate additional menu(s) and parameter(s) as desired.

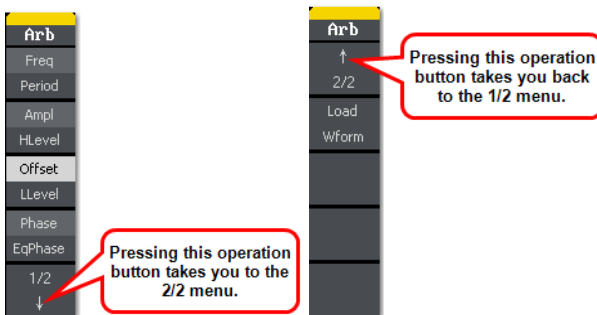

3. Making the actual parameter adjustments or other selection is made a few different ways. Most are done by selecting a **specific parameter** using a **corresponding operation menu button**, changing the value or selection using **Digital Input Front Panel**

**Controls** (on page 27), and then pressing the same corresponding **operation menu button again to preserve the adjustment/selection**. The only variation includes where the interface shows the adjustment/selection choices.

- **Inside the Operation Menu** - Some adjustment/selection choices are shown right on the **Operation** menu.

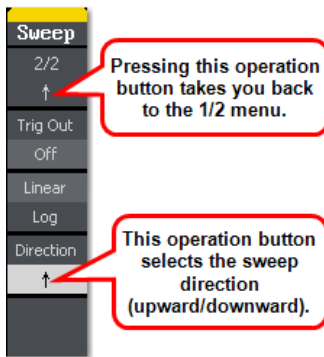

- **On the Display Dialog** - Some adjustment/selection choices are shown right on the **Display** dialog.



## WaveStation

- **On the Detail Dialog** - Some adjustment/selection choices are shown right on the **Detail** dialog.

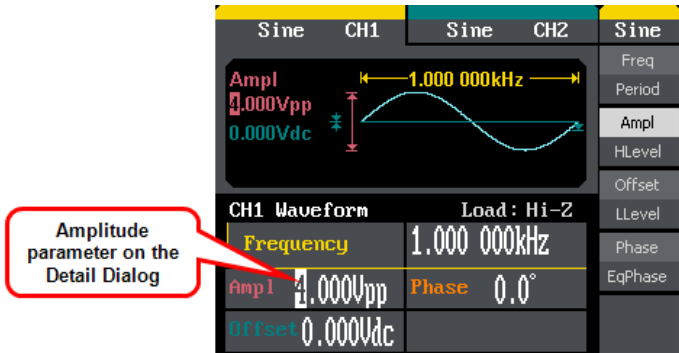

- **On the Browser Display Dialog** - Some interfaces are provided using file explorer-like screens for saving and recalling a variety of folders and file types.



### Waveform Types and Default Parameters

Provided your WaveStation is powered on, a single waveform type is always selected and only one waveform type is selected at a time. Each waveform type (**Sine**, **Square**, **Ramp**, **Pulse**, **Noise**, and **Arb**) contains default parameters when initially selected.

**Note:** When using WaveStation (or any signal generator) it's important to understand the relationship between the **Main Waveform Type** buttons, the **Waveform Signal Conditioning** function buttons, and the **Save/Recall**, **Utility**, and **Help** function buttons. See **Combined Use of Waveform, Function, and Configuration Buttons** (on page 23).

Select waveform types by pressing the corresponding waveform button on the **Front Panel** (on page 13).

1. **Sine** - The default Sine waveform is set to 1 kHz frequency, 4.0 Vpp amplitude and a 0V dc offset. The WaveStation can produce 1  $\mu$ Hz up to 50 MHz (WaveStation 2052) Sine waves.
2. **Square** - The default Square waveform is set to 1 kHz frequency, 4.0 Vpp amplitude, 0V dc offset with a 50% duty cycle. The WaveStation can produce 1  $\mu$ Hz to 25 MHz with variable duty cycle Square waves.
3. **Ramp** - The default Ramp waveform is set to 1 kHz frequency, 4.0 Vpp amplitude, 0V dc offset with a 50% symmetry. The WaveStation can produce 1  $\mu$ Hz to 300 kHz with variable symmetry Ramp waves.
4. **Pulse** - The default Pulse waveform is set to 1 kHz frequency, 4.0 Vpp amplitude, 0V dc offset, 200  $\mu$ s pulse width. The WaveStation can produce 500  $\mu$ Hz to 5 MHz with variable pulse width and delay Pulse waves.
5. **Noise** - The default Noise waveform is set to 2.0V Variance and 10 mV Mean. The WaveStation can produce signal bandwidth up to 50 MHz for Noise waves.
6. **Arb** - The default Arb waveform is set to 1 kHz frequency, 4.0 Vpp amplitude and 0mV dc offset. The WaveStation can produce repeatable arbitrary waveform signals with a 16K point maximum and a 5 MHz frequency.

# WaveStation

---

## Initial Function Settings

Each function (**Modulate**, **Sweep**, **Burst**, **Save/Recall**, **Utility**, and **Help**) contains default settings when initially selected.

Specifically, the top three buttons are **Waveform Signal Conditioning** buttons and apply **Mod**, **Sweep**, or **Burst** functions to the waveform you've selected. Meanwhile, the lower three, **Save/Recall**, **Utility**, and **Help**, are for various WaveStation tools and configurations along with some Help information.

**Note:** When using WaveStation (or any signal generator) it's important to understand the relationship between the **Main Waveform Type** buttons, the **Waveform Signal Conditioning** function buttons, and the **Save/Recall**, **Utility**, and **Help** function buttons. See **Combined Use of Waveform, Function, and Configuration Buttons** (on page 23).

Select a function by pressing the corresponding function button on the **Front Panel** (on page 13).

### **Waveform Signal Conditioning Buttons**

- **Modulate** - Press the **Mod** button and the modulated waveforms you've created using the WaveStation are generated. Waveforms are modulated using **AM**, **FM**, **ASK**, **FSK**, and **PM**.

**Note:** **Sine**, **Square**, **Ramp**, or **Arb** waveforms may be modulated, while **Pulse**, **Noise**, and **DC** cannot.

- **Sweep** - Press the **Sweep** button and the WaveStation produces a signal with variable frequencies.

**Note:** **Sine**, **Square**, **Ramp**, or **Arb** waveforms may be swept, while **Pulse**, **Noise**, and **DC** cannot.

- **Burst** - Press the **Burst** button and the waveforms you've created using the WaveStation are generated for either N-Cycle Burst (a specified number of waveform cycles) or Gated Burst (controlled by an external gated signal).

**Note:** **Sine, Square, Ramp, or Arb** waveforms may be set to an **N-Cycle Burst**, while **Noise** is the only waveform type available for a **Gated Burst**.

### ***Save/Recall, Utility, and Help Buttons***

- **Save/Recall** - Press the **Save/Recall** button to store or arrange waveform data either on the WaveStation itself or on an external memory device. This function is also used for retrieving data previously stored on internal or external memory as well.
- **Utility** - Press the **Utility** button to set **Auxiliary System Functions, Output Parameters, Interface Settings,** and to **View System Setting Information.**
- **Help** - Press the **Help** button and the WaveStation help system is pertaining to the current function or operation is shown.

### **Combined Use of Waveform, Function, and Configuration Buttons**

When using WaveStation (or any signal generator) it's important to understand the relationship between the **Main Waveform Type** buttons, the **Waveform Signal Conditioning** function buttons, and the **Save/Recall, Utility, and Help** function **Front Panel** (on page 13) buttons.

#### ***Main Waveform Buttons***

As mentioned in **Waveform Types and Default Parameters** (on page 21), provided your WaveStation is powered on, a single waveform type is always selected and only one waveform type is selected at a time.

#### ***Waveform Signal Conditioning Function Buttons***

As mentioned in **Initial Function Settings** (on page 22), you apply one of the three signal conditioning function buttons to your selected waveform type for specific **Mod, Sweep, or Burst** functionality.

## WaveStation

Menus are therefore displayed in a prioritized order of **Waveform Type** (one of which is always selected) and a second level of **Mod**, **Sweep**, or **Burst** (one of the three at a time). However, it is not mandatory to apply **Mod**, **Sweep**, or **Burst** functionality to your selected waveform.

Therefore, a second press of the **Mod**, **Sweep**, or **Burst** button turns the LED and function off to reveal the originally selected waveform type menu.

The menu behavior/relationship looks like the following:

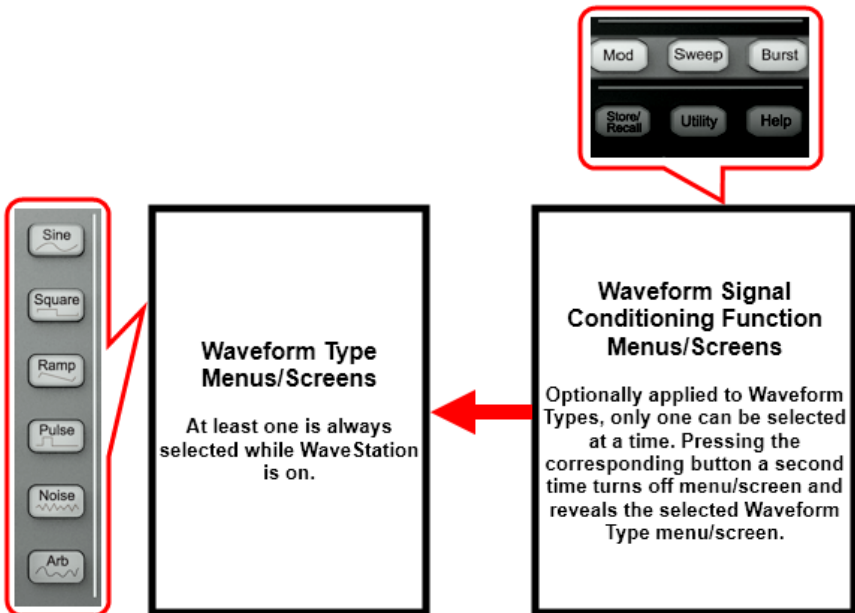

### **Save/Recall, Utility, and Help Function Buttons**

Also mentioned in **Initial Function Settings** (on page 22), while the waveform type and an optional signal conditioning function is (or is not) applied to your signal, you can also use one of the **Save/Recall**, **Utility**, or **Help** function buttons.

So, at any given time, you can press the **Save/Recall**, **Utility**, or **Help** function button, and the corresponding menu is shown. Similar to **Mod**, **Sweep**, or **Burst** these buttons are optional and a second press turns off their corresponding LED and function to reveal either the the **Mod**, **Sweep**, or **Burst** menu if applied to the selected waveform, otherwise, the selected waveform type menu is shown.

The menu behavior/relationship looks like the following:

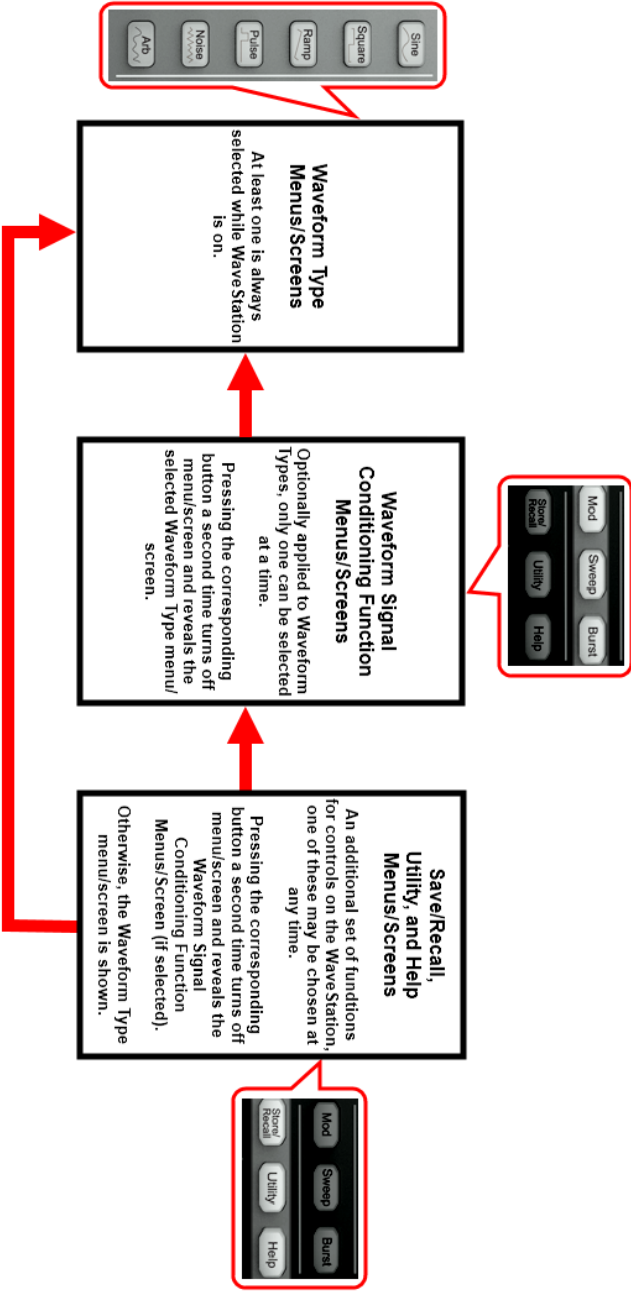

## Digital Input Front Panel Controls

Three sets of buttons - **The Number Buttons**, **The Direction Buttons**, and the **Adjustment Control Knob** - all provide unique means to provide digital input from the **Front Panel** (on page 13) in the following ways:

1. **The Number Buttons** are used to set parameter and input values.
2. **Up and Down Direction Buttons** select through different parameters while the **Left and Right** ones are used to decrease/increase, respectively, preset value increments for a selected parameter. Also used to navigate the Path, Folder, File sections of the Browser display dialog in **Main Save/Recall Operations** (on page 57).

**TIP:** Combine Number and Direction buttons to edit a parameter by using the left direction button to move the cursor backward and delete or change values entered using the number buttons.

3. **The Adjustment Control Knob** allows you to decrease/increase more precise value increments for a selected parameter or select items from listings when by turning the knob counterclockwise/clockwise, respectively.

## Creating Waveforms

### Creating Waveforms Overview

The first step in creating your waveform is to press the corresponding **Waveform** button on the [Front Panel](#).

#### PLEASE NOTE THE FOLLOWING:

- When using WaveStation (or any signal generator) it's important to understand the relationship between the **Main Waveform Type** buttons, the **Waveform Signal Conditioning** function buttons, and the **Save/Recall**, **Utility**, and **Help** function buttons. See **Combined Use of Waveform, Function, and Configuration Buttons** (on page 23).
- Default values for many controls can be set using certain options available on the **Utility** menu. Learn more in **Main Utility Operations** (on page 62).

## WaveStation

This section covers details around creating waveforms and making specific adjustment/selection parameter choices - all of which vary based on the specific waveform selection made.

For more information on getting to this point, see [Navigating Interfaces, Adjusting Parameters, and Making Selections](#) (on page 16).

### Creating a Sine Wave

When first pressing this waveform button on the [Front Panel](#), the WaveStation shows the **Sine Operation** menu and corresponding **Display** and **Detail** dialogs.

Press adjacent Operation buttons and use the **Digital Input Front Panel Controls** (on page 27) to make specific adjustment/selection parameter choices. For more information on getting to this point, see [Navigating Interfaces, Adjusting Parameters, and Making Selections](#) (on page 16).

Sine Operation menu selections and parameters include **Frequency/Period**, **Amplitude/HLevel**, **Offset/LLevel**, **Phase**, and **Duty Cycle** as explained in the remainder of this topic.

#### *Frequency/Period*

With the **Sine** waveform and the **Frequency/Period** operation button **pressed once to select Frequency**, a Sine waveform is shown on the **Waveform Display** and the **Frequency** is shown on the **Waveform Detail** dialog.

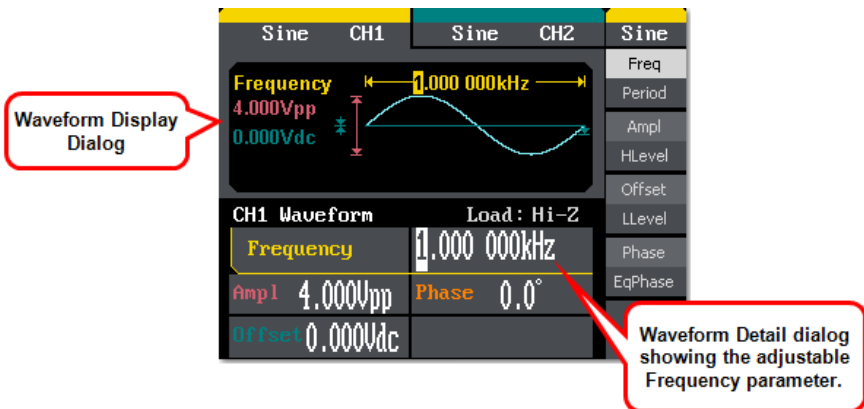

**PLEASE NOTE THE FOLLOWING:**

- Press the **Frequency/Period** operation button a **second time** to select and adjust the **Period** parameter in the same manner.
- While editing certain parameters using the **Number Buttons**, applicable unit(s) are shown on the **Operation** menu. Press an adjacent Operation button to select a desired **Unit** for your entry.

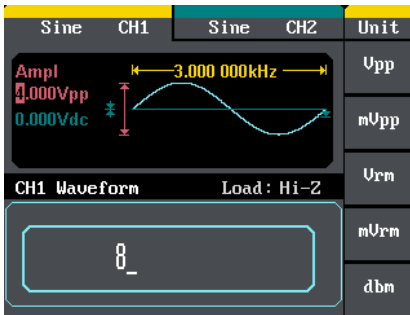

While editing certain parameters using the Number Buttons, applicable unit(s) are shown on the Operation menu. Press an adjacent Operation button to select a desired Unit for your entry.

- Provide your desired **Frequency** or **Period** using the **Digital Input Front Panel Controls** (on page 27).

## Amplitude/HLevel

With the **Sine** waveform and the **Amplitude/HLevel** operation button **pressed once**, a Sine waveform is shown on the **Waveform Display** and **Amplitude** is shown on the **Waveform Detail** dialog.

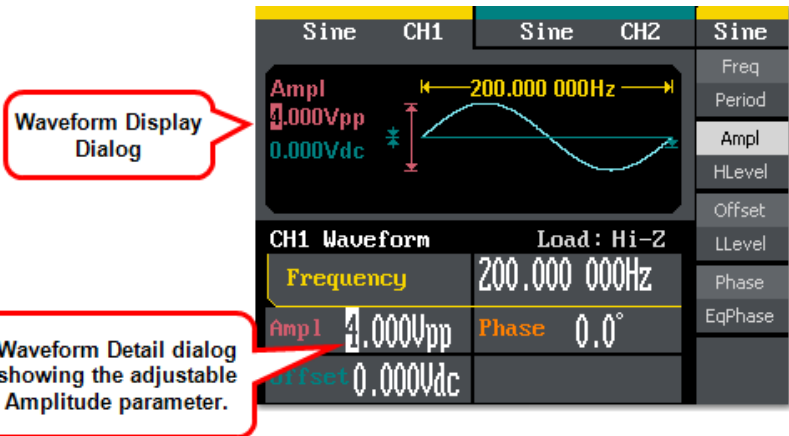

**PLEASE NOTE THE FOLLOWING:**

## WaveStation

- Press the **Amplitude/HLevel** operation button a **second time** to select and adjust the **HLevel** (High Level) parameter in the same manner. Second operation button press parameters are shown in reverse color on the waveform detail dialog to provide a visual indication as to which parameter is being adjusted.
- While editing certain parameters using the **Number Buttons**, applicable unit(s) are shown on the **Operation** menu. Press an adjacent Operation button to select a desired **Unit** for your entry.
- Provide your desired **Amplitude** or **HLevel** using the **Digital Input Front Panel Controls** (on page 27).

### Offset/LLevel

With the **Sine** waveform and the **Offset/LLevel** operation button **pressed once to select Offset**, a Sine waveform is shown on the **Waveform Display** and the **Offset** is shown on the **Waveform Detail** dialog.

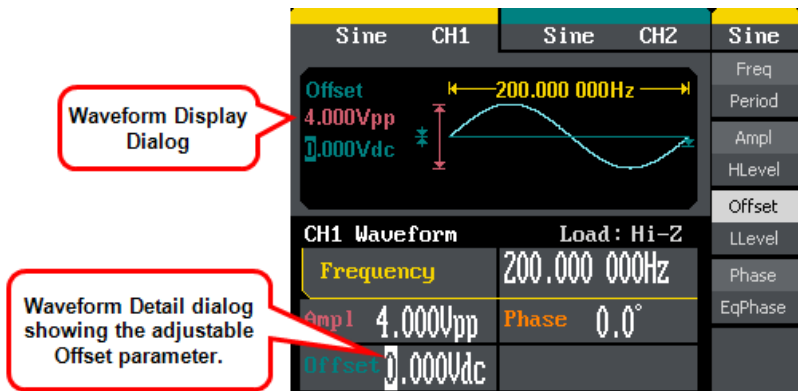

### PLEASE NOTE THE FOLLOWING:

- Press the **Offset/LLevel** operation button a **second time** to select and adjust the **LLevel** (Low Level) parameter in the same manner. Second operation button press parameters are shown in reverse color on the waveform detail dialog to provide a visual indication as to which parameter is being adjusted.
- While editing certain parameters using the **Number Buttons**, applicable unit(s) are shown on the **Operation** menu. Press an adjacent Operation button to select a desired **Unit** for your entry.

- Provide your desired **Offset** or **LLevel** using the **Digital Input Front Panel Controls** (on page 27).

## Phase/EqPhase

With the **Sine** waveform and the **Phase/EqPhase** operation button **pressed once to select Frequency**, a Sine waveform is shown on the **Waveform Display** and the **Phase** is shown on the **Waveform Detail** dialog.

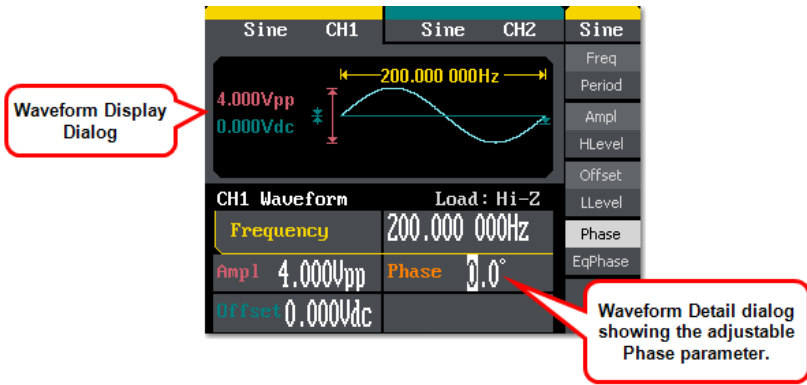

### PLEASE NOTE THE FOLLOWING:

- Press the **Phase/EqPhase** operation button a **second time** to select and adjust the **EqPhase** parameter in the same manner. Second operation button press parameters are shown in reverse color on the waveform detail dialog to provide a visual indication as to which parameter is being adjusted.
- While editing certain parameters using the **Number Buttons**, applicable unit(s) are shown on the **Operation** menu. Press an adjacent Operation button to select a desired **Unit** for your entry.
- Provide your desired **Phase** or **EqPhase** using the **Digital Input Front Panel Controls** (on page 27).

## Creating a Square Wave

When first pressing this waveform button on the **Front Panel**, the WaveStation shows the **Square Operation** menu and corresponding **Display** and **Detail** dialogs.

# WaveStation

Press adjacent Operation buttons and use the **Digital Input Front Panel Controls** (on page 27) to make specific adjustment/selection parameter choices. For more information on getting to this point, see **Navigating Interfaces, Adjusting Parameters, and Making Selections** (on page 16).

**Note:** Square Operation menu selections and parameters include **Frequency/Period, Amplitude/HLevel, Offset/LLevel, Phase, and Duty Cycle**. The parameters for **Frequency/Period, Amplitude/HLevel, Offset/LLevel, Phase** are carried out the same way as done when **Creating a Sine Wave** (on page 28).

Setting the **Duty Cycle** is done as follows:

## Duty Cycle

With the **Square** waveform and the **Duty** (Duty Cycle) operation button pressed, a Square waveform is shown on the **Waveform Display** and **Duty Cycle** is shown on the **Waveform Detail** dialog.

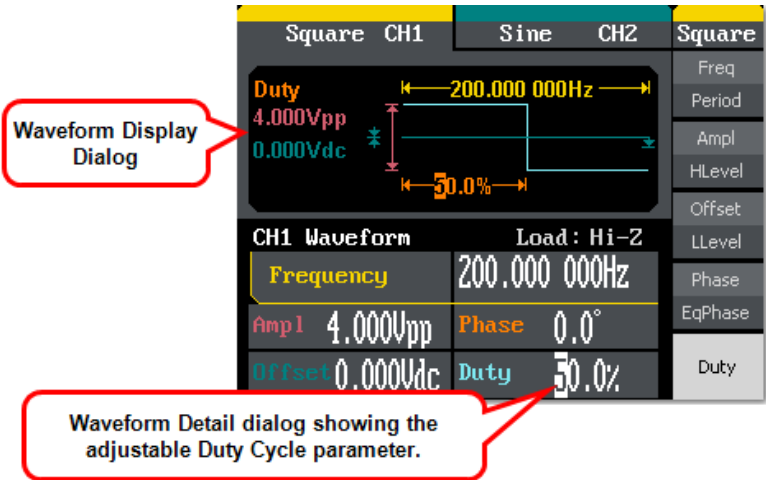

The Duty Cycle is provided as a % percent of the High Level taking up the whole period.

| % of High Level | Frequency             |
|-----------------|-----------------------|
| 20 to 80%       | < 10 MHz              |
| 40 to 60%       | From 10 MHz to 20 MHz |
| 50%             | > 20 MHz              |

**PLEASE NOTE THE FOLLOWING:**

- Press an adjacent Operation button to select a desired **Unit** (unit interval) for your entry.
- Provide your desired **Duty Cycle** amount using the **Digital Input Front Panel Controls** (on page 27).

## Creating a Ramp Wave

When first pressing this waveform button on the [Front Panel](#), the WaveStation shows the **Ramp Operation** menu and corresponding **Display** and **Detail** dialogs.

Press adjacent Operation buttons and use the **Digital Input Front Panel Controls** (on page 27) to make specific adjustment/selection parameter choices. For more information on getting to this point, see **Navigating Interfaces, Adjusting Parameters, and Making Selections** (on page 16).

**Note:** Ramp Operation menu selections and parameters include **Frequency/Period, Amplitude/HLevel, Offset/LLevel, Phase/EqPhase, and Symmetry**. The parameters for **Frequency/Period, Amplitude/HLevel, Offset/LLevel, Phase/EqPhase** are carried out the same way as done when **Creating a Sine Wave** (on page 28).

Setting the **Symmetry** is done as follows:

# WaveStation

## Symmetry

With the **Ramp** waveform and the **Symmetry** operation button pressed, a Ramp waveform is shown on the **Waveform Display** and **Symmetry** is shown on the **Waveform Detail** dialog.

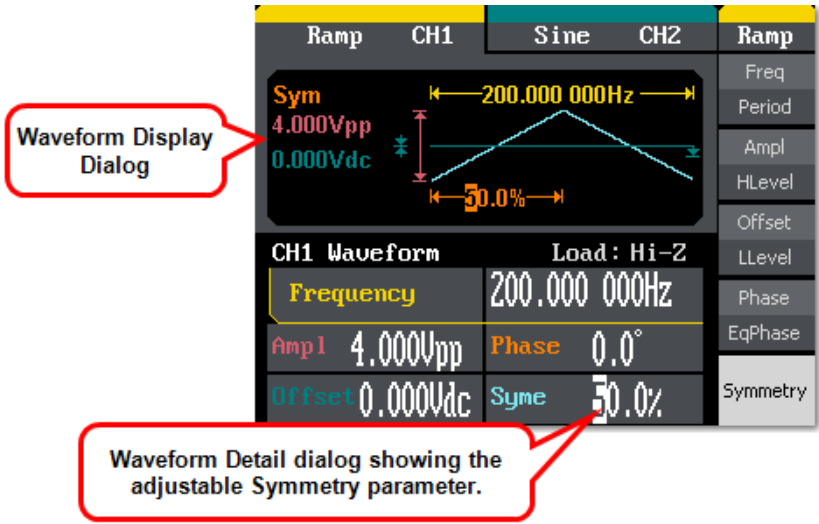

### PLEASE NOTE THE FOLLOWING:

- Press an adjacent Operation button to select a desired **Unit** (unit interval) for your entry.
- Provide your desired **Symmetry** amount using the **Digital Input Front Panel Controls** (on page 27).

## Creating a Pulse Wave

When first pressing this waveform button on the **Front Panel**, the WaveStation shows the **Pulse Operation** menu and corresponding **Display** and **Detail** dialogs.

Press adjacent Operation buttons and use the **Digital Input Front Panel Controls** (on page 27) to make specific adjustment/selection parameter choices.

For more information on getting to this point, see **Navigating Interfaces, Adjusting Parameters, and Making Selections** (on page 16).

**Note:** Pulse Operation menu selections and parameters include **Frequency/Period, Amplitude/HLevel, Offset/LLevel, PulWidth/Duty,** and **Delay**. The parameters for **Frequency/Period, Amplitude/HLevel,** and **Offset/LLevel** are carried out the same way as done when **Creating a Sine Wave** (on page 28).

Setting the **PulWidth/Duty** (Pulse Width) and **Delay** is done as follows:

## **PulWidth/Duty**

With the **Pulse** waveform and the **PulWidth/Duty** operation button pressed once to select **PulWidth**, a Pulse waveform is shown on the **Waveform Display** and the **Pulse Width** is shown on the **Waveform Detail** dialog.

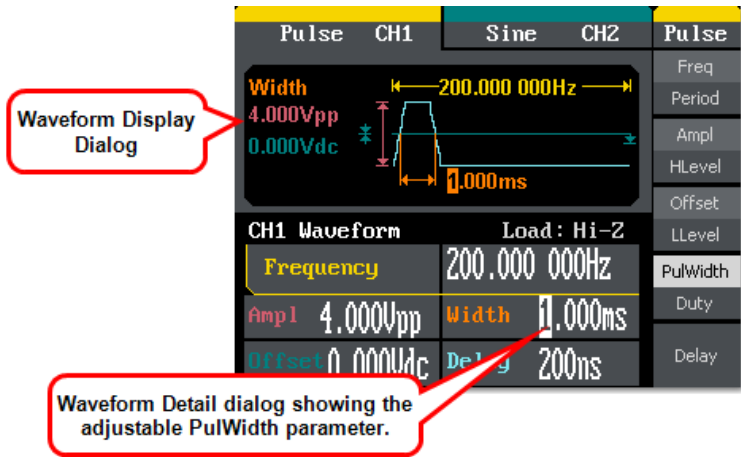

**Positive Pulse Width** is the time from the first rising edge to the first falling edge. Similar for **Negative Pulse Width**.

### **PLEASE NOTE THE FOLLOWING:**

- Press an adjacent Operation button to select a desired **Unit** (unit interval) for your entry.
- Provide your desired **PulWidth** amount using the **Digital Input Front Panel Controls** (on page 27).

# WaveStation

## Delay

With the **Pulse** waveform and the **Delay** operation button **pressed once**, a Pulse waveform is shown on the **Waveform Display** and the **Delay** is shown on the **Waveform Detail** dialog.

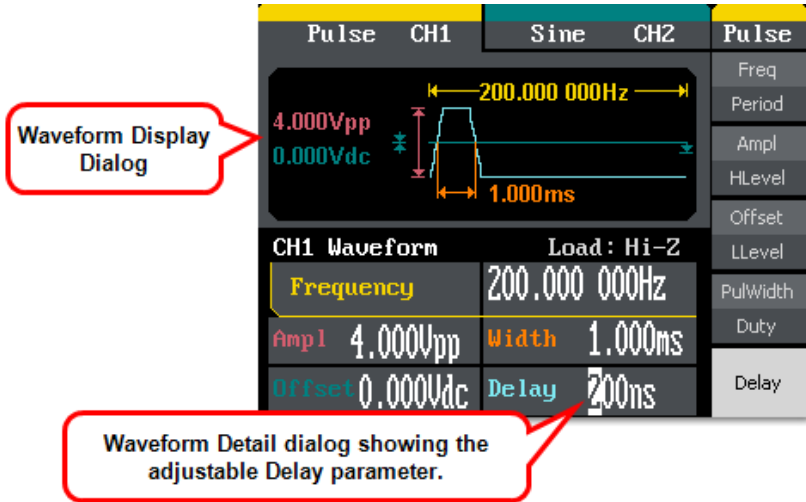

### PLEASE NOTE THE FOLLOWING:

- Press an adjacent Operation button to select a desired **Unit** (unit interval) for your entry.
- Provide your desired **Delay** amount using the **Digital Input Front Panel Controls** (on page 27).

## Creating a Noise Wave

When first pressing this waveform button on the **Front Panel**, the WaveStation shows the **Noise Operation** menu and corresponding **Display** and **Detail** dialogs.

Press adjacent Operation buttons and use the **Digital Input Front Panel Controls** (on page 27) to make specific adjustment/selection parameter choices. For more information on getting to this point, see **Navigating Interfaces, Adjusting Parameters, and Making Selections** (on page 16).

Set **Variance/Mean** values on Noise Waveforms as follows:

## Variance/Mean

With the **Noise** waveform and the **Variance/Mean** operation button **pressed once to select Variance**, a Noise waveform is shown on the **Waveform Display** and **Variance** is shown on the **Waveform Detail** dialog.

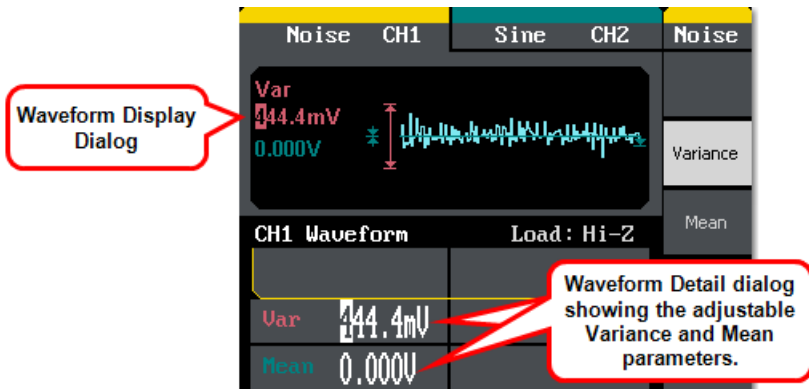

### PLEASE NOTE THE FOLLOWING:

- Press the **Variance/Mean** operation button a **second time** to select and adjust the **Mean** parameter in the same manner.
- While editing certain parameters using the **Number Buttons**, applicable unit(s) are shown on the **Operation** menu. Press an adjacent Operation button to select a desired **Unit** for your entry.
- Provide your desired **Variance** or **Mean** values using the **Digital Input Front Panel Controls** (on page 27).

## Creating an Arbitrary Waveform

When first pressing this waveform button on the [Front Panel](#), the WaveStation shows the **Arb Operation** menu and corresponding **Display** and **Detail** dialogs. There is a **System Default Arb Waveform** and a **User-Defined Arb Waveform**.

## WaveStation

---

Press adjacent Operation buttons and use the **Digital Input Front Panel Controls** (on page 27) to make specific adjustment/selection parameter choices. For more information on getting to this point, see **Navigating Interfaces, Adjusting Parameters, and Making Selections** (on page 16).

### PLEASE NOTE THE FOLLOWING:

- Arb Operation menu selections and parameters include **Frequency/Period, Amplitude/HLevel, Offset/LLevel, Phase/EqPhase**, and **Load Wform**. The parameters for **Frequency/Period, Amplitude/HLevel, Offset/LLevel**, and **Phase/EqPhase** are carried out the same way as done when **Creating a Sine Wave** (on page 28).
- Operation menus containing more parameters than the ones showing on the first menu have a **1/X ↓** final selection. The additional menu(s) therefore have a **2/X ↑** first selection. Press the adjacent button to navigate additional menu(s) and parameter(s) as desired.

Loading a **Stored Waveform** is done as follows:

### **Load Wform**

- Press the **1/2 ↓** button to access the additional Arb Operation menu.
- Now, press the **Load Wform** button.
- An Arb menu showing **Built-In** and **Stored Waveform** options is shown.

**Note:** There are 40+ Built-In Arbitrary Waveforms available in the WaveStation.

## **BUILT-IN ARBITRARY WAVEFORMS**

After selecting **Arb** → **Load Wform** → **Built-In**, a menu is shown categorizing the Built-In Arbitrary Waveforms as follows:

**Note:** After selecting one of the following categories using the adjacent Operation button, the built-in waveforms are shown on the Waveform Display dialog and may be selected using the **Digital Input Front Panel Controls** (on page 27) - specifically, the **Direction Buttons** or the **Control Knob**. Make your selection by pressing the **Select** option button.

- **Common** - Common Built-In Arbitrary Waveforms include **StairUp**, **StairDn**, **StairUD** (Stair Up and Down), **PPulse** (Positive Pulse), **NPulse** (Negative Pulse), **Trapezia** (Trapezoid), **UpRamp**, and **DnRamp**.
- **Math** - Math Built-In Arbitrary Waveforms include **ExpFall** (Exponential Fall), **ExpRise**, **LogFall** (Logarithmic Fall), **LogRise**, **Sqrt** (Square Root), **Root<sup>3</sup>**, **X<sup>2</sup>**, **X<sup>3</sup>**, **Sinc**, **Gaussian**, **Dlorentz** (D-Lorentz), **Haversin** (Haversine), **Lorentz**, **Gauspuls** (Gaussian-modulated sinusoidal pulse), **Gmonpuls** (Gaussian monopulse), and **Tripuls** (triangle pulse).
- **Project** - Project Built-In Arbitrary Waveforms include **Cardiac** (electrocardiogram or ECG), **Quake** (Ioma prieta earthquake), **Chirp** (swept-frequency cosine), **TwoTone** (two tone signal), and **SNR** (sine wave with white noise).
- **Winfun/Triangle** - Winfun/Triangle Built-In Arbitrary Waveforms include **Hamming**, **Hanning**, **Kaiser**, **Blackman**, **Gaussian**, **Triangle**, **Hairs**, **Bartlett**, **Tan**, **Cot**, **Sec**, **Csc**, **Asin**, **Acos**, **Atan**, and **Acot**.
- **Choice** - Choice Built-In Arbitrary Waveforms include **StairUp**, **StairDn**, **StairUD** (Stair Up and Down), **PPulse** (Positive Pulse), **NPulse** (Negative Pulse), **Trapezia** (Trapezoid), **UpRamp**, and **DnRamp**.

# WaveStation

## STORED WAVEFORMS

After selecting **Arb** → **Load Wform** → **Stored Wforms**, the Stored Waveforms are shown on the Waveform Display dialog as follows:

**Note:** Select the stored waveforms showing on the Waveform Display dialog using the **Digital Input Front Panel Controls** (on page 27) - specifically, the **Direction Buttons** or the **Control Knob**. Make your selection by pressing the **Select** option button.



# Generating Modulated Waveforms

## Generating Modulated Waveforms Overview

Specific waveform types may be modulated (as carrier waveforms) using the WaveStation. **Sine**, **Square**, **Ramp**, or **Arb** waveforms may be modulated, while **Pulse**, **Noise**, and **DC** cannot.

The first step in creating your modulated waveform is to press the **Mod** Function button on the [Front Panel](#). Then, select a modulated waveform type from the **AM**, **FM**, **ASK**, **FSK**, **PM**, and **PWM** choices on the Mod operation menu.

### PLEASE NOTE THE FOLLOWING:

- When using WaveStation (or any signal generator) it's important to understand the relationship between the **Main Waveform Type** buttons, the **Waveform Signal Conditioning** function buttons, and the **Save/Recall**, **Utility**, and **Help** function buttons. See **Combined Use of Waveform, Function, and Configuration Buttons** (on page 23).
- Default values for many controls can be set using certain options available on the **Utility** menu. Learn more in **Main Utility Operations** (on page 62).

This section covers details around creating modulated waveforms and making specific adjustment/selection parameter choices - all of which vary based on the specific **function** and **carrier waveform selection** made.

For more information on getting to this point, see **Navigating Interfaces, Adjusting Parameters, and Making Selections** (on page 16).

## Generating an AM (Amplitude Modulation) Modulated Waveform

After selecting the **Mod → AM** modulated waveform operator button as explained in the **Generating Modulated Waveforms Overview** (above), the WaveStation shows the **AM Operation** menu and corresponding **Display** and **Detail** dialogs.

## WaveStation

---

Press adjacent Operation buttons and use the **Digital Input Front Panel Controls** (on page 27) to make specific adjustment/selection parameter choices. For more information on getting to this point, see **Navigating Interfaces, Adjusting Parameters, and Making Selections** (on page 16).

**Mod → AM** Operation menu selections and parameters include **AM Freq**, **AM Depth**, **Type**, **Shape**, and **Source** as follows:

- **AM Freq** - This parameter sets the modulating waveform frequency. The internal source frequency range is 2 MHz to 20 kHz.
- **AM Depth** - This parameter sets the amplitude range.

**Note:** Amplitude **range** is also referred to as amplitude **depth** or **percentage modulation**. It's a percentage value that varies from 1 to 120% . **When set to 0%**, the output amplitude is **approximately half of the user set amplitude value**. **When set to 100%**, the output amplitude **matches the amplitude set**. **When using an external source**, the AM depth is controlled by **the voltage level of the connector attached to Modulation In on the Back Panel** (on page 14).  $\pm 6V$  corresponds to 100% of your current depth setting.

- **Type** - Amplitude modulation.
- **Shape** - Choose the waveform shape type (used as a carrier waveform) for modulation. **Sine**, **Square**, **Ramp**, or **Arb** waveforms may be modulated, while **Pulse**, **Noise**, and **DC** cannot.
- **Source** - Select **Internal** or **External**. If External is selected, use the **Modulation In** connector on the **Back Panel** (on page 14).

## Generating a FM (Frequency Modulation) Modulated Waveform

After selecting the **Mod → FM** modulated waveform operator button as explained in the **Generating Modulated Waveforms Overview** (on page 41), the WaveStation shows the **FM Operation** menu and corresponding **Display** and **Detail** dialogs.

Press adjacent Operation buttons and use the **Digital Input Front Panel Controls** (on page 27) to make specific adjustment/selection parameter choices. For more information on getting to this point, see **Navigating Interfaces, Adjusting Parameters, and Making Selections** (on page 16).

**Mod** → **FM** Operation menu selections and parameters include **FM Freq**, **FM Dev**, **Type**, **Shape**, and **Source** as follows:

- **FM Freq** - This parameter sets the modulating waveform frequency. The internal source frequency range is 2 MHz to 20 kHz.
- **FM Dev** - This parameter sets the maximum frequency deviation.

**Note:** The frequency deviation value should be  $\leq$  the carrier waveform frequency. The sum of the deviation and the carrier waveform frequency should be  $\leq$  the maximum frequency of the selected waveform. When using an external source, the deviation is controlled by the voltage level of the connector attached to **Modulation In** on the **Back Panel** (on page 14). +6V corresponds to the selected deviation and -6V to the negative selected deviation. So, a +/- 6 V input results in an output FM deviation equal to the preset FM deviation

- **Type** - Frequency modulation.
- **Shape** - Choose the waveform shape type (used as a carrier waveform) for modulation. **Sine**, **Square**, **Triangle**, **UpRamp**, **DnRamp**, **Noise**, or **Arb** waveforms may be modulated, while **Pulse**, and **DC** cannot.
- **Source** - Select **Internal** or **External**. If **External** is selected, use the **Modulation In** connector on the **Back Panel** (on page 14).

## Generating an ASK (Amplitude Shift Keying Modulation) Modulated Waveform

After selecting the **Mod** → **ASK** modulated waveform operator button as explained in the **Generating Modulated Waveforms Overview** (on page 41), the WaveStation shows the **ASK Operation** menu and corresponding **Display** and **Detail** dialogs.

## WaveStation

Press adjacent Operation buttons and use the **Digital Input Front Panel Controls** (on page 27) to make specific adjustment/selection parameter choices. For more information on getting to this point, see **Navigating Interfaces, Adjusting Parameters, and Making Selections** (on page 16).

ASK modulation represents digital data as variations in the amplitude of a carrier wave. The amplitude of an analog carrier signal varies in accordance with the bit stream (modulating signal), keeping frequency and phase constant.

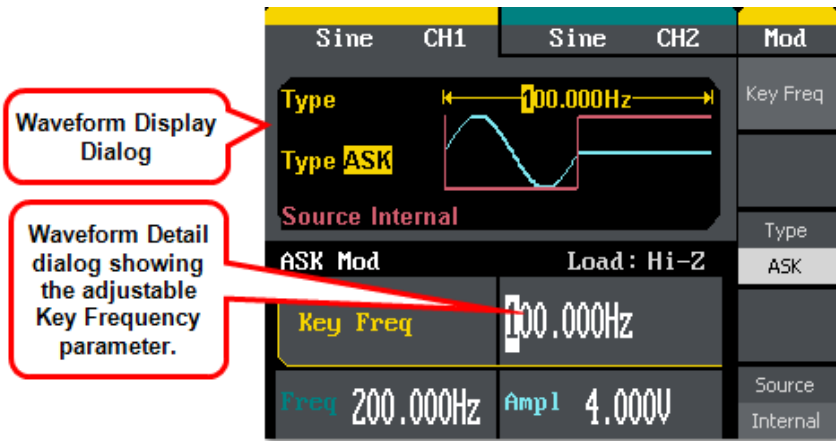

**Mod** → ASK Operation menu selections and parameters include **Key Freq**, **Type**, and **Source** as follows:

- **Key Freq** - This parameter sets the frequency at which the output amplitude shifts between the carrier amplitude and 0. The internal source frequency range is 2 MHz to 50 kHz.
- **Type** - Amplitude Shift Keying Modulation.
- **Source** - Select **Internal** or **External**. If External is selected, use the **Trig/Gate/Fsk/Burst** connector on the **Back Panel** (on page 14).

## Generating an FSK (Frequency Shift Keying Modulation) Modulated Waveform

After selecting the **Mod** → **FSK** modulated waveform operator button as explained in the **Generating Modulated Waveforms Overview** (on page 41), the WaveStation shows the **FSK Operation** menu and corresponding **Display** and **Detail** dialogs.

Press adjacent Operation buttons and use the **Digital Input Front Panel Controls** (on page 27) to make specific adjustment/selection parameter choices. For more information on getting to this point, see **Navigating Interfaces, Adjusting Parameters, and Making Selections** (on page 16).

FSK modulation is an output frequency that switches from the carrier **waveform** and **hop** preset frequencies at a specific point. The specific frequency point where the output switches is the **Key Frequency**. The Key Frequency is determined by the internal frequency generator or the signal voltage level from the **Trig/Gate/Fsk/Burst** connector on the **Back Panel** (on page 14).

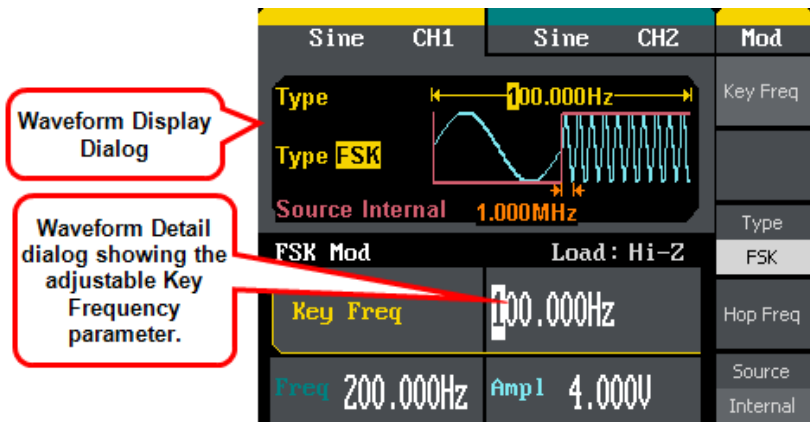

Mod/ASK Operation menu selections and parameters include **Key Freq**, **Type**, and **Source** as follows:

- **Key Freq** - This parameter sets the frequency at which the output frequency shifts between the carrier amplitude and the hop frequency. The internal source frequency range is 2 MHz to 50 kHz.
- **Type** - Frequency Shift Keying Modulation.

## WaveStation

- **Hop Freq** - Specify the desired hop frequency level (for variation from the set carrier waveform frequency).
- **Source** - Select **Internal** or **External**. If External is selected, use the **Trig/Gate/Fsk/Burst** connector on the **Back Panel** (on page 14).

## Generating an PM (Phase Modulation) Modulated Waveform

After selecting the **Mod** → **PM** modulated waveform operator button as explained in the **Generating Modulated Waveforms Overview** (on page 41), the WaveStation shows the **PM Operation** menu and corresponding **Display** and **Detail** dialogs.

Press adjacent Operation buttons and use the **Digital Input Front Panel Controls** (on page 27) to make specific adjustment/selection parameter choices. For more information on getting to this point, see **Navigating Interfaces, Adjusting Parameters, and Making Selections** (on page 16).

Modulated waveforms are one part carrier waveform; the other modulated. For PM, the phase of the carrier waveform varies with the instantaneous voltage level of the modulated waveform.

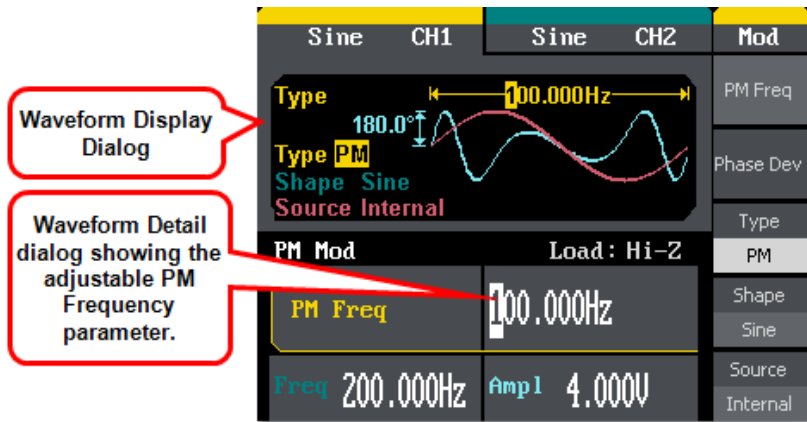

Mod/PM Operation menu selections and parameters include **PM Freq**, **Phase Dev**, **Type**, **Shape**, and **Source** as follows:

- **PM Freq** - This parameter sets the frequency at which the output amplitude shifts between the carrier amplitude and 0. The internal source frequency range is 2 MHz to 50 kHz.
- **Phase Dev** - This parameter sets the maximum phase deviation. Values range from 0° to 360°.
- **Type** - Phase Modulation.
- **Shape** - Choose the waveform shape type (used as a carrier waveform) for modulation. **Sine**, **Square**, **Triangle**, **UpRamp**, **DnRamp**, **Noise**, or **Arb** waveforms may be modulated, while **Pulse**, and **DC** cannot.
- **Source** - Select **Internal** or **External**. If External is selected, use the **Trig/Gate/Fsk/Burst** connector on the **Back Panel** (on page 14).

## Generating Sweep Waveforms

Specific waveform types may be swept (as carrier waveforms) using the WaveStation. **Sine**, **Square**, **Ramp**, or **Arb** waveforms may be swept, while **Pulse**, **Noise**, and **DC** cannot. Frequency sweep mode uses the WaveStation to sweep from the start frequency to the stop frequency at a specified sweep rate.

The first step in creating a sweep waveform is to press the **Sweep** button on the **Front Panel** (on page 13).

### PLEASE NOTE THE FOLLOWING:

- When using WaveStation (or any signal generator) it's important to understand the relationship between the **Main Waveform Type** buttons, the **Waveform Signal Conditioning** function buttons, and the **Save/Recall**, **Utility**, and **Help** function buttons. See **Combined Use of Waveform, Function, and Configuration Buttons** (on page 23).
- Default values for many controls can be set using certain options available on the **Utility** menu. Learn more in **Main Utility Operations** (on page 62).

## WaveStation

---

This section covers sweep waveform creation and making specific adjustment/selection parameter choices - all of which vary based on the specific **function** and **carrier waveform selection** made.

While details around creating waveforms and adjusting specific parameters (which vary based on the specific sweep waveform) are covered here, the following section covers some menu control considerations.

For more information on getting to this point, see **Navigating Interfaces, Adjusting Parameters, and Making Selections** (on page 16).

### Common Sweep Waveform Menu Controls and Considerations

- After pressing the **Sweep** button on the **Front Panel** (on page 13), select the desired modulated waveform type using the **Display Menu Operation** buttons. The waveform is shown on the **Waveform Display**.
- At this point, the **Display Menu Operation** buttons are used to select applicable parameters and make adjustments as desired. A good portion of the waveform operation buttons control two separate parameters. Operation buttons controlling two parameters have additional, lighter shaded function labels on them; press the button **once to adjust the top control parameter; twice to adjust the bottom one**. Make adjustments using the **Digital Input Front Panel Controls** (on page 27).
- Second operation button press parameters are shown in reverse color on the waveform detail dialog to provide a visual indication as to which parameter is being adjusted in the detail dialog.

## PLEASE NOTE THE FOLLOWING:

- Some parameters look like they're first/second press shared and really are not. Instead the parameter title is shown in the top portion and the lower portion displays the particular parameter selection.

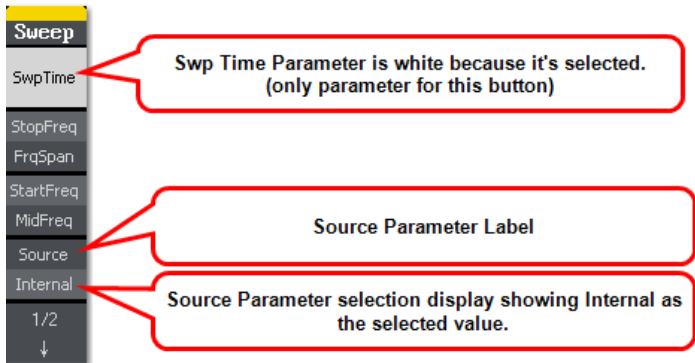

- Operation menus containing more parameters than the ones showing on the first menu have a **1/X ↓** final selection. The additional menu(s) therefore have a **2/X ↑** first selection. Press the adjacent button to navigate additional menu(s) and parameter(s) as desired.

Frequency sweep mode uses the WaveStation to sweep from the start frequency to the stop frequency at a specified sweep rate.

## WaveStation

Press adjacent Operation buttons and use the **Digital Input Front Panel Controls** (on page 27) to make specific adjustment/selection parameter choices.

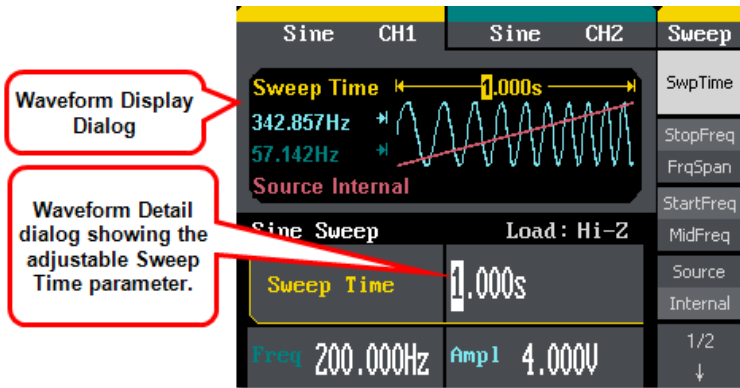

Sweep Operation menu selections and parameters include **SwpTime**, **StopFreq**, **FrqSpan**, **StartFreq**, **MidFreq**, **Source**, **TrigOut**, **Linear/Log**, and **Direction** as follows:

- **SwpTime** - This parameter sets the overall sweep time span in which the frequency changes from specified start frequency to stop frequency values.
- **StopFreq** - Provide a specific frequency value where the sweep must end.
- **FrqSpan** - Provide an overall span or range in which the sweep must remain.
- **StartFreq** - Provide a specific frequency value where the sweep is to begin.
- **MidFreq** - Specify a frequency where the center of the sweep must remain.
- **Source** - Select **Internal**, **External**, or **Manual**. If External is selected, use the **Trig/Gate/Fsk/Burst** connector on the **Back Panel** (on page 14). You can also select **Manual** and specify exact start and stop times.
- **TrigOut** - Select **Off** or **Open**. Open sets trigger on the rising edge of the waveform.

- **Linear/Log** - Press this operation button to highlight and select either **Linear** or **Log** spacing for your sweep waveform.
- **Direction** - Press this operation button to toggle between an **upward (↑)** or **downward (↓)** sweep direction for your waveform.

## Generating Burst Waveforms

Specific waveform types may be burst using the WaveStation. **Sine**, **Square**, **Ramp**, or **Arb** waveforms may be set to an **N-Cycle Burst**, while **Noise** is the only waveform type available for a **Gated Burst**.

The first step in creating a burst waveform is to press the **Burst** button on the **Front Panel** (on page 13).

### PLEASE NOTE THE FOLLOWING:

- When using WaveStation (or any signal generator) it's important to understand the relationship between the **Main Waveform Type** buttons, the **Waveform Signal Conditioning** function buttons, and the **Save/Recall**, **Utility**, and **Help** function buttons. See **Combined Use of Waveform, Function, and Configuration Buttons** (on page 23).
- Default values for many controls can be set using certain options available on the **Utility** menu. Learn more in **Main Utility Operations** (on page 62).

This section covers burst waveform creation and making specific adjustment/selection parameter choices - all of which vary based on the specific **function** and **carrier waveform selection** made.

While details around creating waveforms and adjusting specific parameters (which vary based on the specific burst waveform) are covered here, the following section covers some menu control considerations.

For more information on getting to this point, see **Navigating Interfaces, Adjusting Parameters, and Making Selections** (on page 16).

### Common Burst Waveform Menu Controls and Considerations

- After pressing the **Burst** button on the **Front Panel** (on page 13), select the desired modulated waveform type using the **Display Menu Operation** buttons. The waveform is shown on the **Waveform Display**.
- At this point, the **Display Menu Operation** buttons are used to select applicable parameters and make adjustments as desired. A good portion of the waveform operation buttons control two separate parameters. Operation buttons controlling two parameters have additional, lighter shaded function labels on them; press the button **once to adjust the top control parameter; twice to adjust the bottom one**. Make adjustments using the **Digital Input Front Panel Controls** (on page 27).
- Second operation button press parameters are shown in reverse color on the waveform detail dialog to provide a visual indication as to which parameter is being adjusted in the detail dialog.

## PLEASE NOTE THE FOLLOWING:

- Some parameters look like they're first/second press shared and really are not. Instead the parameter title is shown in the top portion and the lower portion displays the particular parameter selection.

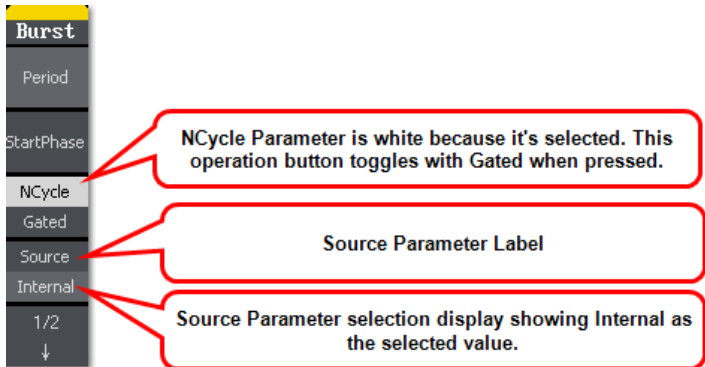

- Operation menus containing more parameters than the ones showing on the first menu have a **1/X ↓** final selection. The additional menu(s) therefore have a **2/X ↑** first selection. Press the adjacent button to navigate additional menu(s) and parameter(s) as desired.

Press adjacent Operation buttons and use the **Digital Input Front Panel Controls** (on page 27) to make specific adjustment/selection parameter choices.

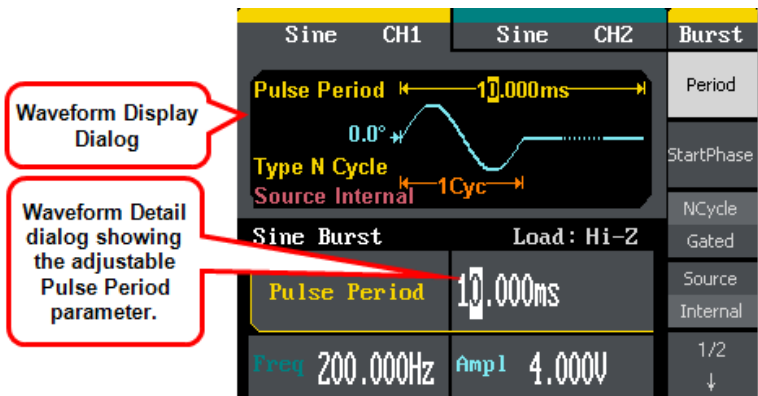

## WaveStation

---

Burst Operation menu selections and parameters include **Period**, **StartPhase**, **NCycle/Gated**, **Source**, **TrigOut**, **Cycles/Infinite**, and **Delay** as follows:

- **Period** - This control is only available when NCycle is selected from the third operation button. Press the Period operation button and provide a specific value for the **Pulse Period** control using the detail dialog.
- **StartPhase** - Press this operation button and provide a specific phase value (in °) using the detail dialog to define the starting point of the waveform. The phase varies from 0° to 360°, and the default setting is 0°. For an Arbitrary Waveform, 0° is the first waveform point.
- **NCycle/Gated** - Press this operation button to select either NCycle or Gated for your burst waveform(s). Many controls on the Burst operation menu change based on the selection made on this control. When NCycle is selected, you can press the Period operation button and provide a specific value for the **Pulse Period** control using the detail dialog.

**Note:** The period time increases if necessary to allow the specified number of cycles in a burst. The following formula is applied to the logic of this control:

$$\text{Burst Period} > \text{Carrier Period} \times \text{Burst Number}$$

N-Cycle has a specific number of waveform cycles and every burst is activated by a trigger event, whereas a Gated burst is activated by an external source.

- **Source** - This control is only available when NCycle is selected from the third operation button. Select **Internal**, **External**, or **Manual**. If External is selected, use the **Trig/Gate/Fsk/Burst** connector on the **Back Panel** (on page 14). You can also select **Manual** and specify exact start and stop times.
- **TrigOut** - This control is only available when NCycle is selected from the third operation button. Select **Off**, **rising edge (↑)**, or **falling edge (↓)** as desired.

- **Cycles/Infinite** - This control is only available when NCycle is selected from the third operation button. Press this operation button to highlight and select either **Cycles** or **Infinite** amounts for your burst waveform(s). With Cycle selected, provide a desired amount of repetitions (from 1 to 50,000) using the detail dialog. Infinite generates a continuous waveform that only stops on a trigger event.

**PLEASE NOTE THE FOLLOWING:**

- The period time increases if necessary to allow the specified number of cycles in a burst as previously mentioned in the NCycle/Gated bullet.
- An external or manual trigger is required in order to activate an infinite burst.
- **Delay** - This control is only available when NCycle is selected from the third operation button. With Delay selected, you can specify a span of time between the trigger input and the start of the N-Cycle burst using the detail dialog. The minimum delay amount is 240 ns.
- **Polarity** - This control is only available when Gated is selected from the third operation button. Press this operation button to select either **Positive** or **Negative** polarity for your gated signal.

# Save/Recall

## Save/Recall Overview

The first step when using the **Save/Recall** is to press the corresponding Save/Recall function button on the **Front Panel** (on page 13).

The following interface is shown with the Store Operation menu on the right side of the screen.

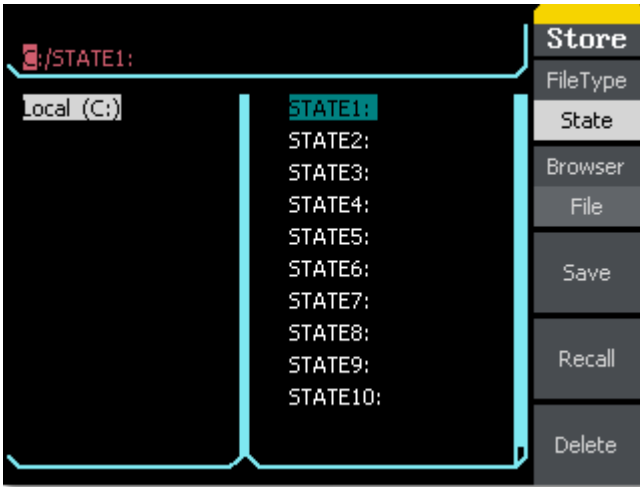

### PLEASE NOTE THE FOLLOWING:

- When using WaveStation (or any signal generator) it's important to understand the relationship between the **Main Waveform Type** buttons, the **Waveform Signal Conditioning** function buttons, and the **Save/Recall**, **Utility**, and **Help** function buttons. See **Combined Use of Waveform, Function, and Configuration Buttons** (on page 23).
- Default values for many controls can be set using certain options available on the **Utility** menu. Learn more in **Main Utility Operations** (on page 62).

## Main Save/Recall Operations

After pressing the **Save/Recall** button on the **Front Panel** (on page 13), select the desired function using the corresponding **Display Menu Operation** buttons.

**Note:** Default values for most save/recall parameters may be set using certain options available from the Utility menu. Learn more in **Main Utility Operations** (on page 62).

The main screen area or Browser shows a Path, Directory, File display dialog which is used with **Digital Input Front Panel Controls** (on page 27) to specify locations for saved and recalled items.

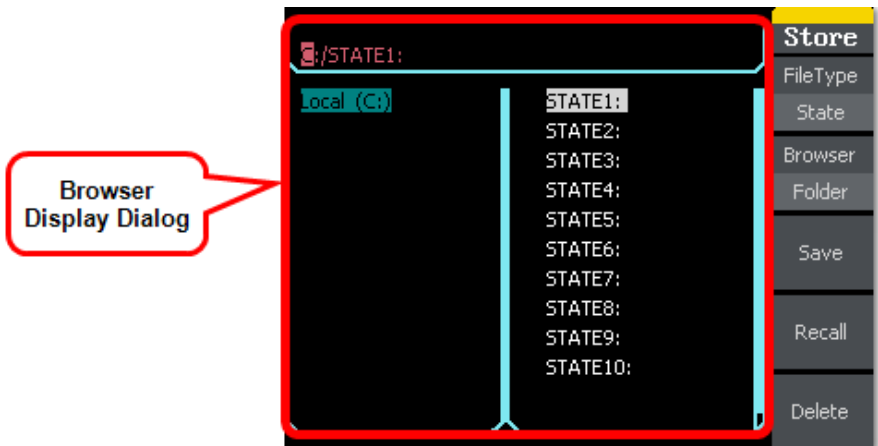

While details around saving and recalling different folders and file types are covered here, the following section covers some menu control considerations.

For more information on getting to this point, see **Navigating Interfaces, Adjusting Parameters, and Making Selections** (on page 16).

### **Common Save/Recall Menu Controls and Considerations**

- After pressing the **Save/Recall** button on the **Front Panel** (on page 13), the **Display Menu Operation** buttons are used to select applicable parameters and make adjustments as desired.

## WaveStation

---

A good portion of the operation buttons control two separate parameters. Operation buttons controlling two parameters have additional, lighter shaded function labels on them; press the button **once to adjust the top control parameter; twice to adjust the bottom one**. Make adjustments using the **Digital Input Front Panel Controls** (on page 27).

- Second operation button press parameters are shown in reverse color on the waveform detail dialog to provide a visual indication as to which parameter is being adjusted in the detail dialog.

### PLEASE NOTE THE FOLLOWING:

- Some parameters look like they're first/second press shared and really are not. Instead the parameter title is shown in the top portion and the lower portion displays the particular parameter selection.

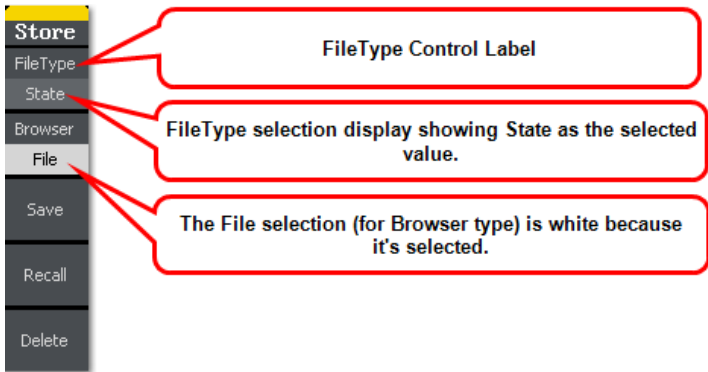

- Some operation menus contain more parameters than the ones showing on the first menu. When this is the case, a **1/X ↓** final selection is provided. The additional menu(s) therefore have a **2/X ↑** first selection. Press the adjacent button to navigate additional menu(s) and parameter(s) as desired.

### **Operation Menu Selections and Parameters**

Operation menu selections and parameters for Save/Recall include the following:

- **FileType** - This control contains State, Data, and All File options based on which kinds of files are being used. **State (or Setup)** handles various WaveStation setup files, **Data** handles arbitrary waveform files, and **All File** is used when storing or recalling any other file type.

**PLEASE NOTE THE FOLLOWING:**

- When saving **State (Setup)** or **Data (Arbitrary Waveforms)** onto your WaveStation, 10 specific **Memory Banks** are provided for each type on the **File** section of the Browser.
  - When a Save is completed, the name you provide is shown to the right of the specific bank.
- **Browser** - This control contains **Path**, **Folder**, and **File** options.

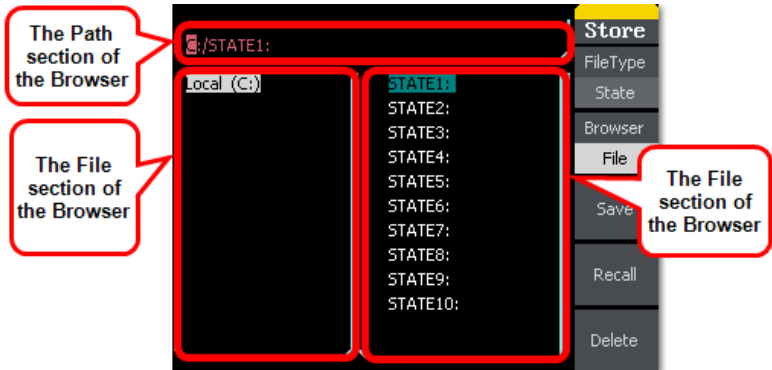

Successively pressing the Browser option button places the cursor in corresponding sections of the **Browser** display dialog where you can then use **Digital Input Front Panel Controls** (on page 27) to make appropriate input selections.

**Note:** The **Direction Buttons** on the **Digital Input Front Panel Controls** (on page 27) are used to make **Folder** and **File** selections which are then shown on the **Path** display area of the Browser.

- **Save** - Once you've made all selections on the aforementioned control options for Setup or Data and navigated to the desired storage location, press this control button to and **Save** your file.

# WaveStation

## PLEASE NOTE THE FOLLOWING:

- If you're saving **State (Setup)** or **Data (Arbitrary Waveforms)** onto your WaveStation, onto one of their 10 specific **Memory Banks**, and select a Bank/File location already containing previously stored information, **your new information always overwrites the old.**
- When saving information, **Digital Input Front Panel Controls** (on page 27) are used to provide a file name in the following manner:

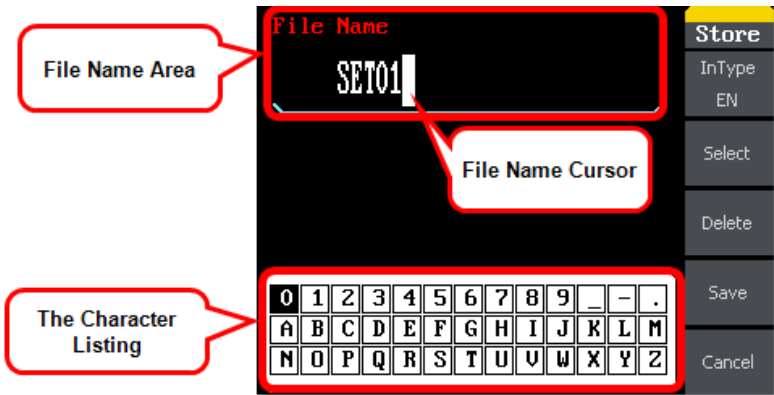

- Press **The Number Buttons** to quickly input a number or character.
- Use the **Up and Down Direction Buttons** to switch rows from your immediate position on the character listing, and the **Adjustment Control Knob** to sequentially move through the character listing.
- Use the **Left and Right Direction Buttons** to move the cursor in a linear fashion through your **Filename**.
- With the desired character highlighted on the listing and your cursor in the desired location within your **Filename**, press the **Select** button to add it to your **Filename**.
- When finished providing your Filename, press the **Save** option button to store your file.
- The **Delete** option button erases characters as it moves the cursor backward through your **Filename**.

- o Use the **Cancel** option button if you wish to return to the main Save/Recall menu without saving your file.

**Note:** Refer to the **WaveStation PC Software Overview** (on page 78) to learn how to transfer waveform files between the WaveStation and your PC.

- **Recall** - You can retrieve stored Setups or Data by navigating to the desired file stored on either WaveStation itself or from a USB device.
  - o Use the Browser controls to navigate to the desired file for retrieval.
  - o With the **specific file** highlighted on the **File** display area on the Browser, press the **Recall** control button.
  - o A status message should then be shown on the **bottom of the Folder display** area indicating the read completed successfully.

**Note:** Refer to the **WaveStation PC Software Overview** (on page 78) to learn how to transfer waveform files between the WaveStation and your PC.

- **Delete** - You can delete stored Setups or Data by navigating to the desired file stored on either WaveStation itself or from a USB device.
  - o Use the Browser controls to navigate to the desired file for deletion.
  - o With the **specific file** highlighted on the **File** display area on the Browser, press the **Delete** control button.
  - o A confirmation menu is shown with Done and Cancel buttons. Press the **Done** button to complete the deletion.

### PLEASE NOTE THE FOLLOWING:

- **USB memory devices** are automatically shown as mapped as **USB Device (A:)** on the **Folder** section of the **Browser** when plugged into your WaveStation **Front Panel** (on page 13).

## WaveStation

---

- **External Hard Drives** are not supported for use as **USB flash memory**. The front USB is meant for use by what is commonly known as **memory sticks** or **thumb drive** devices.

## Utility

### Utility Overview

The first step when using **Utility** is to press the corresponding Utility function button on the **Front Panel** (on page 13).

**Note:** When using WaveStation (or any signal generator) it's important to understand the relationship between the **Main Waveform Type** buttons, the **Waveform Signal Conditioning** function buttons, and the **Save/Recall, Utility, and Help** function buttons. See **Combined Use of Waveform, Function, and Configuration Buttons** (on page 23).

### Main Utility Operations

After pressing the **Utility** button on the **Front Panel** (on page 13), select the desired function using the corresponding **Display Menu Operation** buttons.

While details around the Utility operations are covered here, the following section covers some menu control considerations.

For more information on getting to this point, see **Navigating Interfaces, Adjusting Parameters, and Making Selections** (on page 16).

### *Common Util Menu Controls and Considerations*

- After pressing the **Util** button on the **Front Panel** (on page 13), the **Display Menu Operation** buttons are used to select applicable values and make selections as desired.

A good portion of the operation buttons control two separate parameters. Operation buttons controlling two parameters have additional, lighter shaded function labels on them; press the button **once to adjust the top control parameter; twice to adjust the bottom one**. Make adjustments using the **Digital Input Front Panel Controls** (on page 27).

- Second operation button press parameters are shown in reverse color on the waveform detail dialog to provide a visual indication as to which parameter is being adjusted in the detail dialog.

## PLEASE NOTE THE FOLLOWING:

- Some parameters look like they're first/second press shared and really are not. Instead the parameter title is shown in the top portion and the lower portion displays the particular parameter selection.

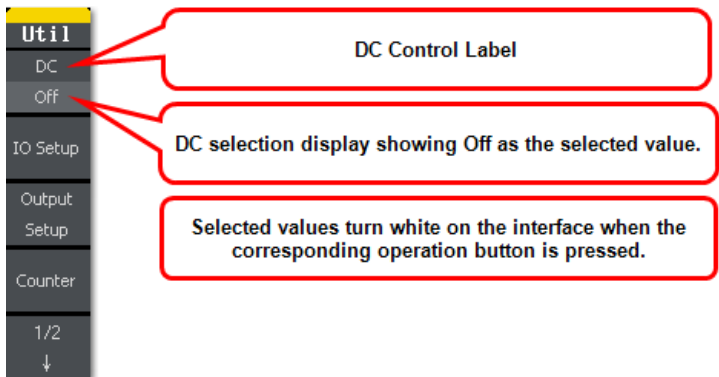

- Some operation menus contain more parameters than the ones showing on the first menu. When this is the case, a **1/X ↓** final selection is provided. The additional menu(s) therefore have a **2/X ↑** first selection. Press the adjacent button to navigate additional menu(s) and parameter(s) as desired.

## Utility Operation Menu Selections and Parameters

The following operations are available from the Util menu option buttons. Some are explained in the remainder of this section. Where necessary, even more detail is provided in subsequent topics to clearly explain their proper use.

- **DC** - The DC switch offers the options of direct current output (On) or Arbitrary Waveform Output (Off). Pressing the option button turns the **DC On** and shows an additional menu where you can

## WaveStation

---

quickly select a **1/-1V** or **2/-2V DC Offset** using corresponding option buttons.

**Note:** After pressing either **1/-1V** or **2/-2V DC Offset** option buttons, the **Adjustment Control Knob** may also be used to dial in the desired level within a -3 to 3V range.

- **IO Setup** - After pressing the IO Setup option button, an additional menu is shown where you can set **USB** or **GPIB** input/output options.
  - o Press the **USB Setup** option button and an additional menu is shown where you can choose either **USBRAW** or **USBTMC** options by pressing corresponding option buttons for the USB connector on the **Back Panel** (on page 14) of your WaveStation.

### PLEASE NOTE THE FOLLOWING:

- Be sure to make the USBRAW setting before connecting to WaveStation from a PC using the **WaveStation PC Software**. For more detailed installation instructions, see **Installing the WaveStation PC Drivers and Software** (on page 79).
- Be sure to make the USBTMC setting before connecting to WaveStation from a PC using **VISA**. Download the latest copy of NI-VISA at [www.ni.com/visa/](http://www.ni.com/visa/).
- o Press the GPIB option button and use the **Adjustment Control Knob** from the **Digital Input Front Panel Controls** (on page 27) to provide a specific GPIB Address value. This GPIB enables the USB connector on the **Front Panel** (on page 13) of your instrument.

### PLEASE NOTE THE FOLLOWING:

- Be sure to make the correct **GPIB Address** setting **before** connecting to WaveStation from a PC using **The USB-GPIB Adapter** (on page 76).

- The USB connector on the Front Panel is also used for **USB memory sticks**. USB memory sticks are plug-and-play supported and no special setting is needed for their use.
  - o Make selections as desired and press the **Done** (to commit) or **Cancel** option button and the main **Util** menu is shown.
- **Output Setup** - Press this option button and an additional menu is shown.

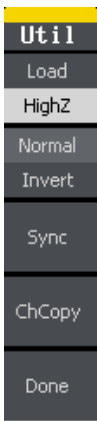

Press the Output Setup option button on the Utility menu and an additional menu with corresponding controls is shown.

Use these additional output controls for the following:

- o **Load/HighZ** - Use this option button to select either **Load** or **HighZ** for your waveform output.
- o **Normal/Invert** - Use this option button to select either **Normal** or **Invert** for your waveform output.
- o **Sync** - Press this option button and an additional menu is provided where you can turn the State of your synchronization **On/Off** and use the **Channel** option button to send the synchronized signal to CH1 or CH2.

Make selections as desired and press the **Done** (to commit) or **Cancel** option button and the main **Util** menu is shown.

All standard output functions (except DC and Noise) have a corresponding Sync signal sent through the **Sync Out** connector on the **Back Panel** (on page 14). This can be disabled on certain settings as follows:

## WaveStation

---

- **Default** - The Sync signal should be connected to the activated Sync Out connector on the Back Panel. When the Sync Signal is disabled, the output voltage of the [Sync] connector is set to low level.
  - **Inverse** - In this mode, the Waveform corresponding to the Sync Signal does not inverse.
  - **Non-Modulated Waveforms** - The Sync Signal reference is the carrier signal on non-modulated waveforms.
  - **AM, FM, and PM** - Internal modulating waveforms (AM, FM, and PM) the Sync signal reference is the modulated signal
  - **ASK and FSK** - The Sync Signal Reference is the keying Frequency.
  - **Sweep** - Once the sweep starts, the Sync Signal becomes TTL Level High. The Sync frequency equals the specific Sweep time.
  - **Burst** - For the Burst, when the burst starts, the Sync Signal is Level High.
  - **External Gated Burst** - The Sync Signal follows the External Gated Signal.
  - **Pulse** - The Sync Signal is a Pulse Signal with a fixed positive pulse width more than 50 ns.
- o **ChCopy** - Press this option button and an additional menu is provided where you can port a particular channel's configuration to another. Option buttons are labeled as **CH1->CH2** and **CH2->CH1** accordingly.

Make selections as desired and press the **Done** (to commit) or **Cancel** option button and the main **Util** menu is shown.

- **System** - Press this option button on the **2/2** main **Util** menu and additional menus (there's actually two - shown here side by side for convenience) are provided where you can make various default settings on your WaveStation.

| Util     | Util      |
|----------|-----------|
| Number   | ↑         |
| Format   | 2/2       |
| Language | Beep      |
| English  | On        |
| PowerOn  | ScrnSvr   |
| Default  | 15min     |
| Set to   | CLKSource |
| Default  | Internal  |
| 1/2      | Done      |
| ↓        |           |

Press the **System** option button on the **Utility** menu and additional menus with corresponding controls are shown. They're provided here side-by-side for convenience.

**Note:** The menus don't appear on the WaveStation this way and are provided here side-by-side for convenience.

When corresponding option buttons are pressed and the item is selected for **Number Format**, **Language**, **PowerOn**, **Set to Default**, **Beep**, **ScrnSvr**, and **CLKSource**, only Number Format provides an additional menu where the **Point** (period or comma) and **Separator** (Space, Off, or On) format may be chosen. The **Cancel** option button may also be pressed and returns you to the main **Util** menu.

## WaveStation

Otherwise, subsequent presses of corresponding buttons select the available values.

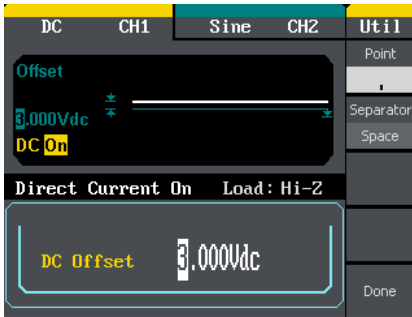

Press the Number Format option button on the System menu and an additional menu with the following options is shown.

**Note:** When selecting the **Set to Default** option button, your WaveStation is restored to various factory settings as described in **Restoring the Default Settings** (on page 73).

Make selections as desired and press the **Done** (to commit) option button and the **System** menu is shown.

- **Test/Cal** - Press this option button on the **2/2** main **Util** menu and an additional menu with option buttons for **SelfTest** and **SelfCal** is provided.
  - Press the **SelfTest** option button and an additional menu is provided where you can select a **Scr(Screen)Test**, **KeyTest**, or **LEDTest**. After making your selection a corresponding screen is shown where the **7** or **8** front panel buttons are used in specific ways to either proceed with the test and/or exit the test screen, respectively.

**Screen, Keyboard, and LED Test** screens look like the following:

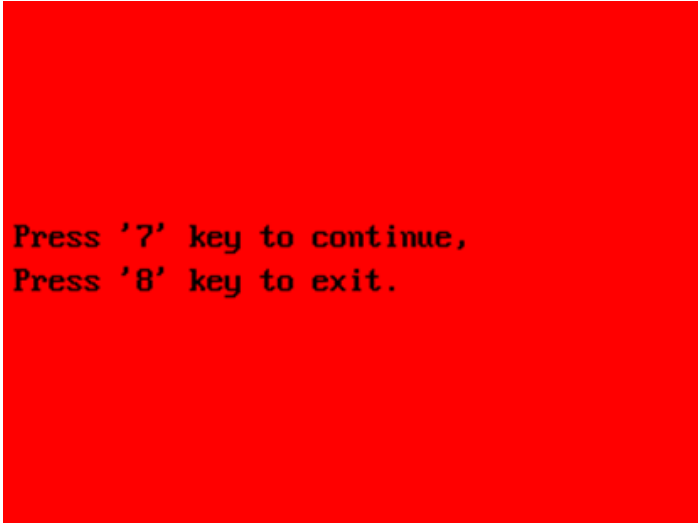

Press '7' key to continue,  
Press '8' key to exit.

*Screen Test - Each press of the 7 front panel button runs successively through colors and is how the Screen Test is performed. Move through a few colors until you are satisfied. As the screen indicates, press the 8 front panel button to exit.*

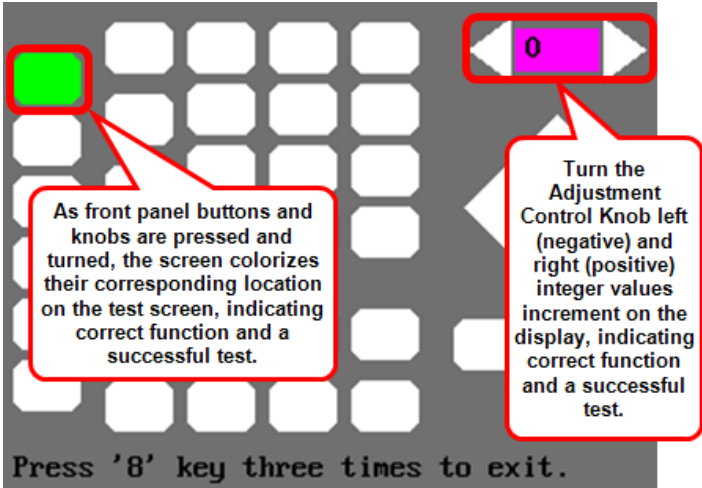

*Keyboard Test - As front panel buttons and knobs are pressed and turned, the screen colorizes their corresponding location on the test screen, indicating a successful test. Test all of the instruments buttons and knobs as desired. As the screen indicates, pressing the 8 front panel button three times exits the keyboard test.*

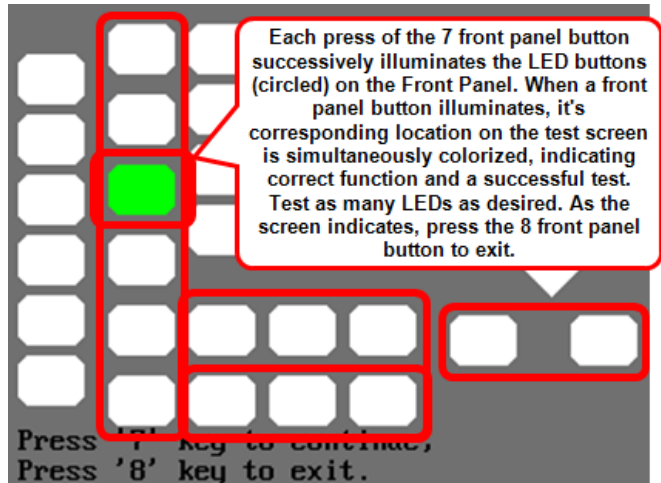

***LED Test - Each press of the 7 front panel button illuminates successively from the Waveform Type buttons, to the Waveform Signal Conditioning buttons, to the Save/Recall, Utility, and Help buttons, to the two Output buttons (since these are the only LED buttons on the Front Panel). When a front panel button illuminates, it's corresponding location on the test screen is simultaneously colorized, indicating correct function and a successful test. Test as many LEDs as desired. As the screen indicates, press the 8 front panel button to exit.***

- o Press the **SelfCal** option button and the WaveStation starts a series of calibration tests as a progress bar is shown on the Display Dialog indicating the percentage of completion. When the progress reaches 100%, press any key to continue.
- o The **Cancel** option button may also be pressed and returns you to the **2/2** main **Util** menu.

## WaveStation

---

- **EditInfo** - Press this option button and a WaveStation firmware version details screen is shown and contains details for **Boot-Strap Number, Software Version, Hardware Version, Model Number, and Serial Number**.

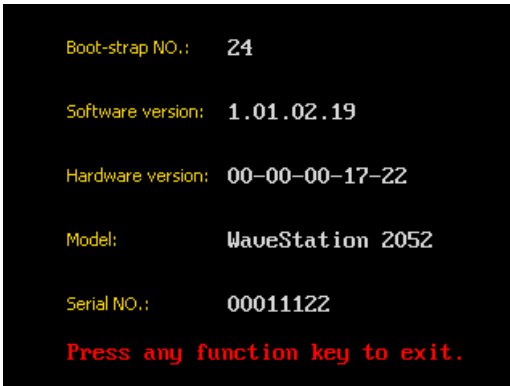

Exit the screen by pressing any Option, Waveform, or Function button on the **Front Panel** (on page 13).

- **Update** - Firmware updates are made available for the WaveStation function/arbitrary waveform generator and may be downloaded from [www.lecroy.com](http://www.lecroy.com).

The firmware update download contains a file with a .ads extension. This is the file needed for your firmware update. Copy this file onto a USB memory stick.

Now, select the Update option button on the **2/2** main **Util** menu and the main **Save/Recall** screen is shown.

At this point, plug your USB memory stick into the USB connector on the **Front Panel** (on page 13) of your WaveStation.

Navigate to your stored .ads file on your memory stick (mapped to drive A). With the **.ads file selected on the File section of the Browser**, press the **Recall** option button.

**Note:** At this point the firmware update begins. **Do not power off the WaveStation for any reason during this process.** Doing so can render your WaveStation inoperable.

## Restoring the Default Settings

The WaveStation function/arbitrary waveform generator is set up for normal operation when it is shipped from the factory. After making changes to various settings, the

defaults can be restored in the following manner:

- Press the **System** option button on the **2/2** main **Util** menu.
- Then, press the **Set to Default** option button on the **Util/System** menu.

The default settings made to WaveStation are detailed on the following tables:

| Output           | Default Value |
|------------------|---------------|
| Function         | Sine Wave     |
| Frequency        | 1 kHz         |
| Amplitude/Offset | 4 Vpp/0 V DC  |
| Phase            | 0°            |
| Terminals        | High Z        |

| Modulation        | Default Value    |
|-------------------|------------------|
| Carrier           | 1 kHz Sine Wave  |
| Modulating        | 100 Hz Sine Wave |
| AM Depth          | 100%             |
| FM Deviation      | 500 Hz           |
| Key Freq          | 100 Hz           |
| FSK Hop Frequency | 1 MHz            |
| Phase Deviation   | 180°             |

## WaveStation

| Sweep                | Default Value  |
|----------------------|----------------|
| Start/Stop Frequency | 100 Hz/1.9 kHz |
| Sweep Time           | 1 S            |
| Trig Out             | Off            |
| Mode                 | Linear         |
| Direction            | ↑              |

| Burst  | Default Value |
|--------|---------------|
| Period | 10 ms         |
| Phase  | 0°            |
| Count  | 1 Cycle       |
| Trig   | Off           |

| Trigger | Default Value |
|---------|---------------|
| Source  | Internal      |

## Using WaveStation Help

The first step when using **Help** is to press the corresponding Help function button on the **Front Panel** (on page 13).

After pressing the Help function button, a listing of very shortened versions of various help topics based on the information in this manual is provided right on your WaveStation.

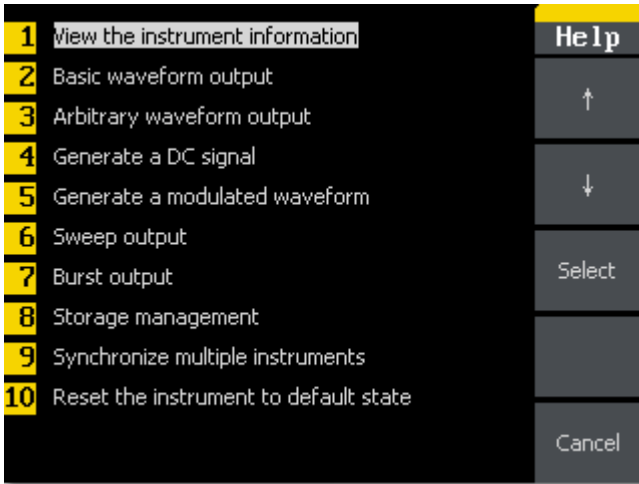

- Use the **Arrow** option buttons to move up and down the list.
- Highlight the desired topic on the list, and then press the **Select** option button to display the content on the main screen.
- When inside a selected topic, press the **Cancel** option button and the main listing of topics are then shown again. Otherwise, pressing **Cancel** from the main listing of topics takes you out of the Help system.

The information in this manual is supplemented by a SCPI (Standard Commands for Programmable Instruments) Command Reference Manual available on [www.lecroy.com](http://www.lecroy.com).

Additional supplemental information in the form of Application Notes and LabBriefs are also always available on [www.lecroy.com](http://www.lecroy.com).

If you have questions unanswered by our materials, please **Contact LeCroy for Support** (on page 93).

# Controlling WaveStation with USB-GPIB and/or USBTMC

## Controlling WaveStation with USB-GPIB and/or USBTMC

WaveStation can be controlled using either USB-GPIB (for GPIB) or USBTMC (for VISA) protocols. First, use the following steps to make a setting on your WaveStation to receive the desired protocol. This is described in the **Main Utility Operations** (on page 62) topic, however, the quick location is provided here:

- The **USB-GPIB Setting** is located at **Utility** → **IO Setup** → **GPIB**.
- The **USBTMC Setting** is located at **Utility** → **IO Setup** → **USB Setup** → **USBTMC**.

### PLEASE NOTE THE FOLLOWING:

- For more information, please refer to the SCPI (Standard Commands for Programmable Instruments) Command Reference Manual available on [www.lecroy.com](http://www.lecroy.com).
- WaveStation requires remote commands **NOT** contain termination characters of any kind. This includes Null characters.

## The USB-GPIB Adapter

You use USB-GPIB and USBTMC controls to remotely connect from a PC to your WaveStation. If USB-GPIB is used, the USB-GPIB Adapter is needed to make the connection from your PC to your WaveStation.

The USB-GPIB adapter connects the USB host interface on your product to the GPIB bus controller and command set. The GPIB and USB on the adapter conforms to IEEE 488.2 and USB 2.0, respectively.

- The USB connection provides all necessary power.
- LED indicators in the Signal Generator provide an adapter connection status.

- GPIB controls can interface with compatible LeCroy oscilloscopes and, if desired, a GPIB address may be used.

**Note:** The GPIB interface specifically supports Device (and not Controller) mode.

### Connecting Your Adapter

First, make sure you've set your WaveStation to receive the USB-GPIB connection. This is described in **Controlling WaveStation with USB-GPIB and/or USBTMC** (on page 76) and in the **Main Utility Operations** (on page 62) topic. The default address for the adapter is **13**.

Now, use the following steps to **attach your adapter** and know **what the LED indicator lights mean**.

1. **Attach the USB side** of the connector to the interface on the LeCroy compatible oscilloscope. **Connect the GPIB side** of the connector to your Laptop or Desktop computer.

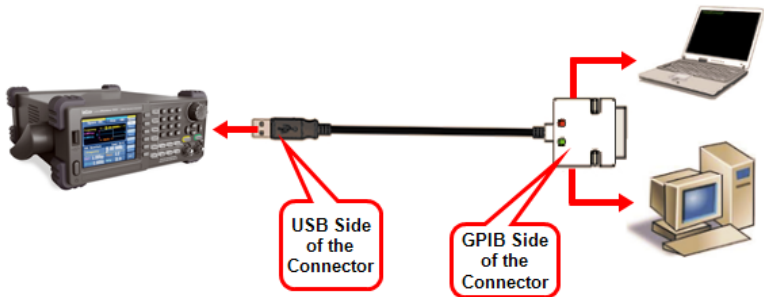

2. **Verify the GPIB address** on the oscilloscope. When making the USB-GPIB setting on your This address number is set when configuring your WaveStation for the USB-GPIB connection. Ensure the address is correct. The default address for the adapter is **13**.

**Note:** The GPIB address is then saved in the GPIB card on your oscilloscope.

## WaveStation

---

3. **Two LED indicators on the GPIB side** of the connector indicate red when the adapter has **power** and yellow when **communicating** data.

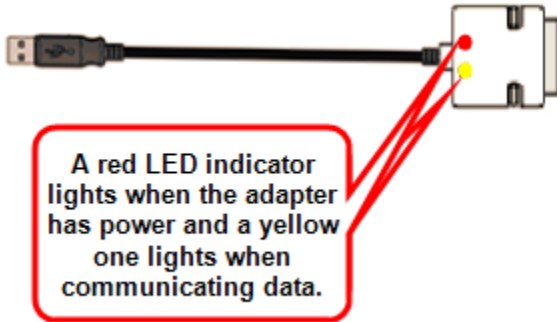

**Note:** Once connected, do not unplug USB or GPIB ends from oscilloscope and/or computer respectively before powering down all equipment first.

## WaveStation PC Software

### WaveStation PC Software Overview

You can use the WaveStation Software to send and receive waveform files over a PC connection with your WaveStation. You can make modifications to Waveform files using the software, save the files, and then see your changes on your WaveStation.

Topics in this section cover the aforementioned and explain the following:

- **Making the WaveStation - PC Software Connection** - Connecting to your WaveStation using your PC and the WaveStation Software
- **Modifying Waveform Files From WaveStation to PC/Software** - Modify a Waveform on WaveStation, Send it to Your PC, See the Changes Using the Software
- **Modifying Waveform Files From PC/Software to WaveStation** - Modify a Waveform on your PC Using the Software, Send it to Your WaveStation and See the Changes

**Note:** It's important to realize that a scalar representation of the waveform data is sent. Adjust the amplitude, frequency, and offset as desired.

### ***Minimum and Suggested WaveStation Software System Requirements***

#### **MINIMUM SYSTEM REQUIREMENTS**

- Operating system Microsoft™ Windows® XP, Windows® Vista 32 Bit Version, Windows® 7 32 Bit Version.
- Pentium® IV processor.
- 1 Gb RAM.
- 150 Mb hard disk available space for software set-up.
- Video resolution 800 X 600.
- USB 2.0 connections.

### **Installing the WaveStation PC Drivers and Software**

In order to use WaveStation with your PC, you must install the drivers and software in the following order:

1. First, turn on your WaveStation and configure the rear USB connector for **USBRAW** as explained in **Main Utility Operations** (on page 62). The setting can quickly be made at **Utility** → **IO Setup** → **USB Setup** → **USBRAW**.
2. With your PC turned on, connect the 1 m USB 2.0 Type A to Type B Cable from the rear of WaveStation to a USB connector on your PC.
3. Your PC eventually should indicate that it's installing/looking for the driver. If shown, you can close pop-ups or screens shown from the connection of the USB cable.
  - On your PC, right-click **Computer** or **My Computer** and select **Manage**. The **Computer Management** screen is shown.
  - Select **Device Manager** under **System Tools** on the left side of the Computer Management screen.

## WaveStation

---

- On the center portion of the Computer Management screen, open the listing for **Universal Serial Bus controllers**.
  - Right-click the **LeCroy Series function/arbitrary Waveform Generator** listing shown under Universal Serial Bus controllers and select **Properties**. On the pop-up, click the **Properties** button on the lower-right.
  - On the new pop-up shown, click the **Update Driver** button on the lower-right of its General tab.
  - Another pop-up is shown. Select to **Browse my computer for driver software**. On the next screen shown on the pop-up, use the Browse button to navigate to the installation disc (insert the disc into your PC if you haven't already). Look for a Driver folder and the applicable subfolder for either 32 or 64-Bit installation.
  - If you're prompted by Windows Security, select to **Install this driver software anyway**.
4. The pop-up indicates when the driver installation successfully updates. Close all the windows left open as part of the driver installation process and launch Windows File Explorer. Now, you may navigate to the installation disc, locate **setup.exe**, and launch the WaveStation PC Software installer.

## Making the WaveStation - PC Software Connection

To share waveform data between your WaveStation and a PC, you must first install the WaveStation PC Software on your the PC you plan to use with your WaveStation.

Next, your WaveStation must have the USB connector on the **Back Panel** (on page 14) enabled for a USBRAW connection. This is described in the **Main Utility Operations** (on page 62) topic, however, the quick location is provided here:

- The **USBRAW Setting** is located at **Utility → IO Setup → USB Setup → USBRAW**.

Finally, make the USB cable connection from the Back Panel of the WaveStation to your PC. On the PC, launch the WaveStation PC Software. Now your WaveStation and your PC are ready to share waveform data.

## WaveStation

### Modifying Waveform Files from WaveStation to PC Software

With your WaveStation - PC Software connection completed as explained in **Making the WaveStation - PC Software Connection** (on page 80), you now need to save **Data (Arbitrary Waveform)** in one of their 10 specific **Memory Banks** on your WaveStation as explained in **Main Save/Recall Operations** (on page 57). Otherwise, you can pull one of the many preset Arb files stored on WaveStation as explained in the **Stored Waveforms** section of **Creating an Arbitrary Waveform** (on page 37).

**Note:** When you save a **Data (Arbitrary Waveform)** to a Bank/File location already containing previously stored information, **your new information always overwrites the old.**

Now, launch the WaveStation PC Software and select **Communication** → **Read wave** from the menu bar.

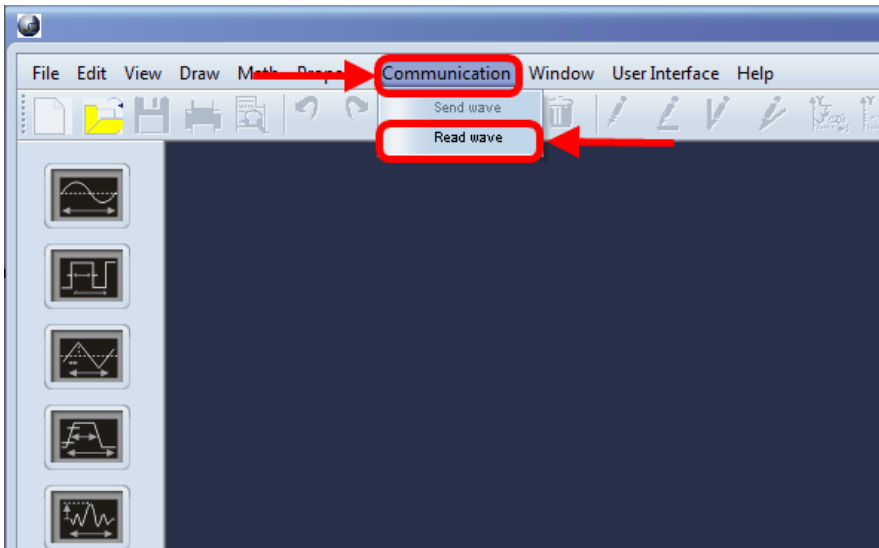

You can also just click the **Read wave** button on the lower part of the WaveStudio PC Software.



## WaveStation

The **Read wave** pop-up is then shown and provides a **Wave list** control showing all the waveforms (**Data - Arbitrary Waveform** and **Stored Waveforms**) stored on your connected WaveStation.

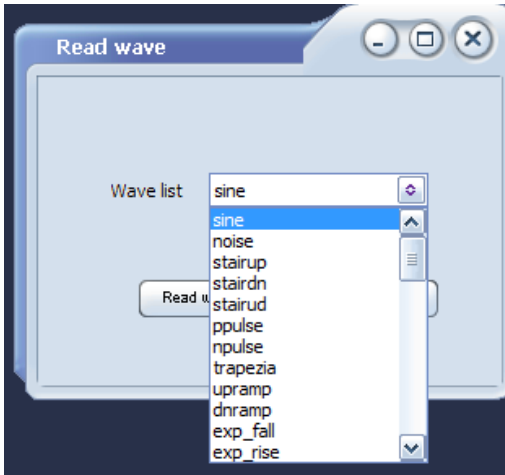

Select the desired waveform from the **Wave list** drop-down on the **Read wave** pop-up and click the **Read wave** button to pull the waveform from your WaveStation onto your PC.

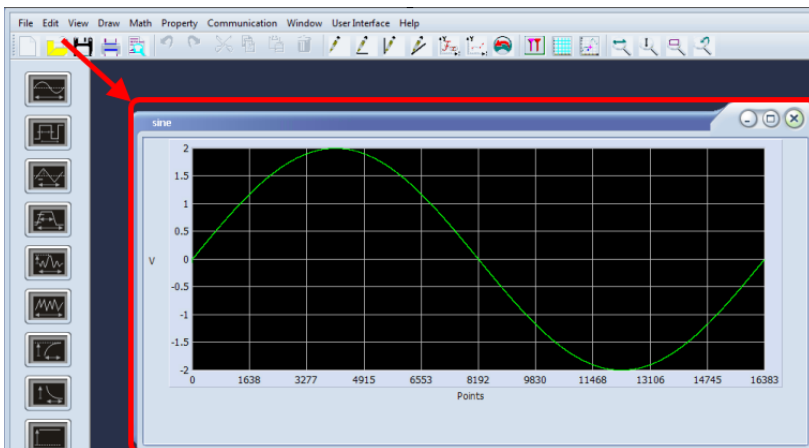

**Note:** A scalar representation of the waveform data is sent. Adjust the amplitude, frequency, and offset as desired.

## Modifying Waveform Files from PC Software to WaveStation

With your WaveStation - PC Software connection completed as explained in **Making the WaveStation - PC Software Connection** (on page 80), you now need to create and save **Data (Arbitrary Waveform)** using the WaveStation PC Software.

Select **File → New** from the menu bar and the **Property setting** pop-up is shown.

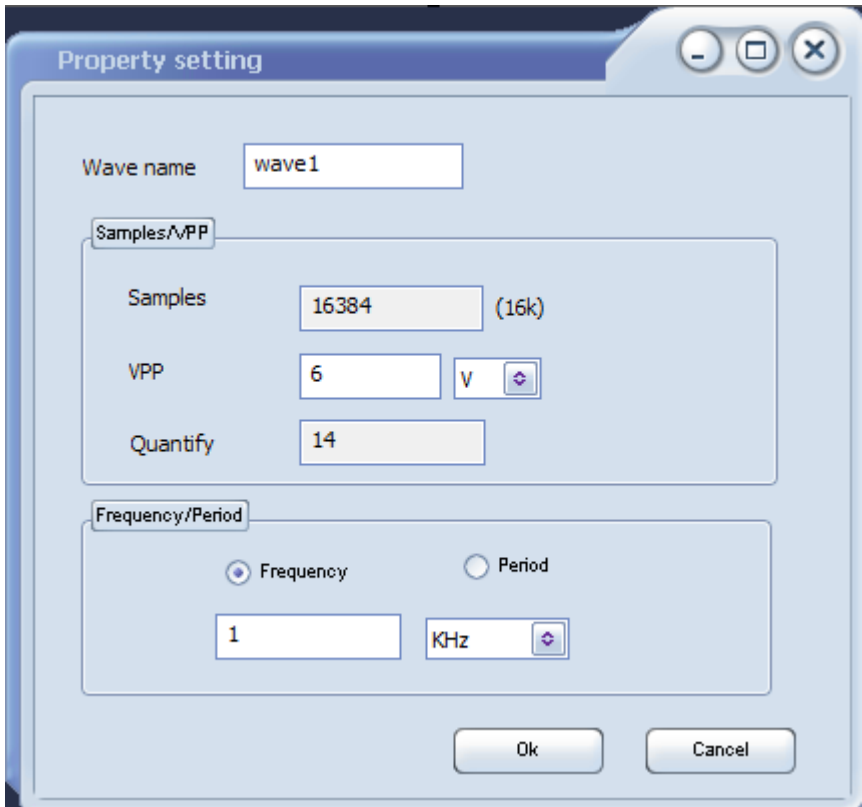

# WaveStation

Provide a **Name** for your waveform and, if desired, provide details for **Samples, VPP, Quantify, Frequency, and Period**. Click the **Ok** button when finished and your new Waveform is shown.

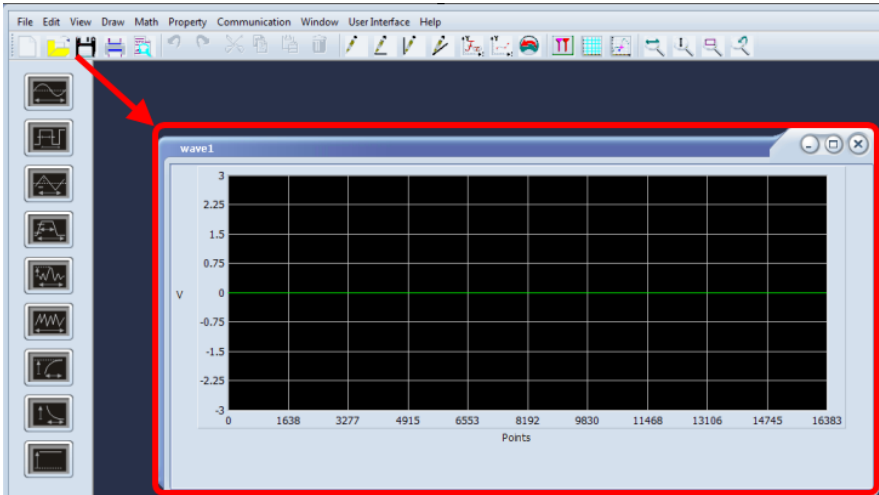

Now, you can modify your waveform as desired by either selecting one of the **Waveform Type** buttons or using various **Waveform Drawing Tools**.

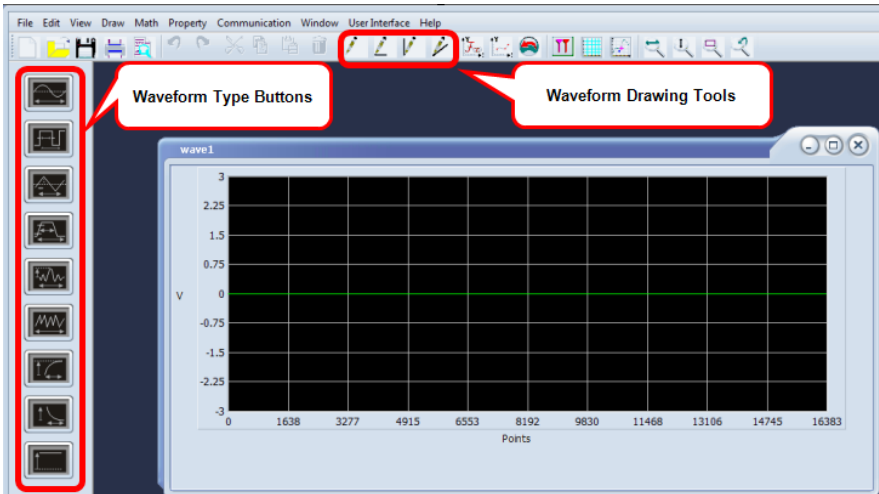

With your waveform setup as desired, click the Save button.

Now, transfer your waveform file to WaveStation by selecting **Communication** → **Send wave** from the menu bar or, click the **Send wave** button on the lower interface.

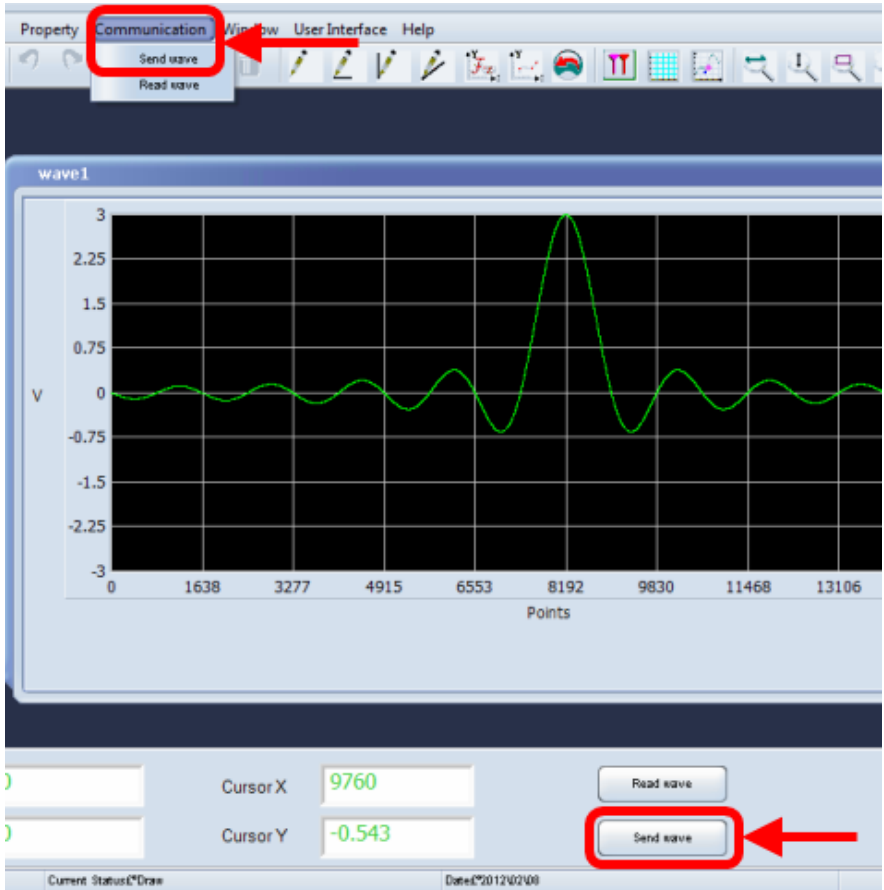

The Send wave pop-up is then shown. Select one of the 10 ARB waveform bank locations for saving your waveform (from the **Store location** control) and exactly which waveform for saving to WaveStation (from the **Name** control) and click the **Send** button.

**Note:** When you save a **Data (Arbitrary Waveform)** to a Bank/File location already containing previously stored information, **your new information always overwrites the old.**

## WaveStation

---

Now, retrieve the sent ARB sent to your WaveStation as explained in **Main Save/Recall Operations** (on page 57), by pressing the Save/Recall **Front Panel** (on page 13) button, selecting Data using the FileType operation button, selecting your waveform on the **File** display area on the Browser, pressing the **Recall** control button.

The waveform you created using the PC Software is now shown in your WaveStation.

### PLEASE NOTE THE FOLLOWING:

- A status message should then be shown on the **bottom of the Folder display** area indicating the read completed successfully.
- A scalar representation of the waveform data is sent. Adjust the amplitude, frequency, and offset as desired.

## Reference

### Specifications

**Note:** Specifications are subject to change without notice.

Please refer to the LeCroy website at [www.lecroy.com](http://www.lecroy.com) for the most current specification information regarding your product.

## CERTIFICATIONS

CE Compliant

### ***CE Declaration of Conformity***

The instrument meets requirements of EMC Directive 2004/108/EEC for Electromagnetic Compatibility and Low Voltage Directive 2006/95/EEC for Product Safety.

### ***EMC DIRECTIVE***

- EN 61326-1:2006
- EMC requirements for electrical equipment for measurement, control, and laboratory use.

### **ELECTROMAGNETIC EMISSIONS:**

- EN 55011/A2:2002, Radiated and conducted emissions (Class A)\*
- EN 61000-3-2:2006 Harmonic Current Emissions (Class A)
- EN 61000-3-3/A2:2005 Voltage Fluctuations and Flickers (Pst = 1)

### **ELECTROMAGNETIC IMMUNITY:**

- EN 61000-4-2:2001\*\* Electrostatic Discharge.  
(4 kV contact, 8 kV air, 4 kV vertical/horizontal coupling planes)
- EN 61000-4-3:2006\*\* RF Radiated Electromagnetic Field.  
(3 V/m, 80-1000 MHz; 3 V/m, 1400 MHz - 2 GHz; 1 V/m, 2 GHz - 2.7 GHz)
- EN 61000-4-4:2004\*\* Electrical Fast Transient/Burst.  
(1 kV on power supply lines, 0.5 kV on I/O signal data and control lines)

## WaveStation

---

- EN 61000-4-5:2006\*\* Surges.  
(1 kV AC Mains, L-N, L-PE, N-PE)
  - EN 61000-4-6:2007\*\* RF Conducted Electromagnetic Field.  
(3 Vrms, 0.15 MHz - 80 MHz)
  - EN 61000-4-11:2004† Mains Dips and Interruptions.  
(1 cycle voltage dip, 100% short interruption)
- 

\* In order to conform to Radiated Emissions standards, use properly shielded cables on all I/O terminals.

\*\* Meets Performance Criteria "B" limits during the disturbance; product undergoes a temporary degradation or loss of function of performance which is self recoverable.

† Meets Performance Criteria "C" limits during the disturbance; product undergoes a temporary degradation or loss of function of performance which requires operator intervention or system reset.

---



This is a Class A product. In a domestic environment this product may cause radio interference, in which case the user may be required to take appropriate measures.

---

### ***LOW-VOLTAGE DIRECTIVE***

EN 61010-1:2001

Safety requirements for electrical equipment for measurement, control, and laboratory use.

**The instrument has been qualified to the following EN 61010-1 limits:**

- Installation Categories II (Mains Supply Connector) and I (Measuring Terminals).
  - Pollution Degree 2 (Normally only dry non-conductive pollution occurs. Occasionally a temporary conductivity caused by condensation must be expected.)
-

## UL and cUL

The instrument is UL and cUL listed and conforms to the following standards:

- UL Standard: UL 61010-1 2nd Edition.
- Canadian Standard: CSA-C22.2 No. 61010-1-04.

## China RoHS Compliance

| 部件名称   | 有毒有害物质和元素 |           |           |                            |               |                 |
|--|-----------|-----------|-----------|----------------------------|---------------|-----------------|
|  | 铅<br>(Pb) | 汞<br>(Hg) | 镉<br>(Cd) | 六价铬<br>(Cr <sup>6+</sup> ) | 多溴联苯<br>(PBB) | 多溴二苯醚<br>(PBDE) |
| PCBA <sub>s</sub>  | X         | O         | X         | X                          | X             | X               |
| 机械硬件   | O         | O         | X         | O                          | O             | O               |
| 金属片  | O         | O         | X         | O                          | O             | O               |
| 塑料部件   | O         | O         | O         | O                          | X             | X               |
| 电缆组件   | X         | O         | X         | O                          | X             | X               |
| 显示器  | X         | O         | X         | X                          | X             | X               |
| 电源   | X         | X         | X         | O                          | X             | X               |
| 风扇   | X         | O         | X         | O                          | X             | X               |
| 处理器电源  | X         | O         | X         | O                          | O             | O               |
| 电源线  | X         | O         | X         | O                          | X             | X               |
| 外部电源(如有)   | X         | X         | X         | O                          | X             | X               |
| 探头(如有)   | X         | O         | X         | O                          | X             | X               |
| 光驱(如有)   | X         | O         | X         | O                          | X             | X               |
| 熔丝(如有)   | X         | O         | X         | O                          | O             | O               |
| 产品外壳(如有)   | O         | O         | O         | O                          | X             | X               |
| 适配器 模块(如有)   | X         | O         | O         | O                          | O             | O               |
| 鼠标(如有)   | X         | O         | X         | O                          | X             | X               |
| O: 表明该有毒有害物质在该部件所有均质材料中的含量均在 SJ/T11363-2006标准规定的限量要求之下。  |           |           |           |                            |               |                 |
| X: 表明该有毒有害物质至少在该部件的某一均质材料中的含量超过 SJ/T11363-2006标准规定的限量要求。 |           |           |           |                            |               |                 |

EFUP (对环境友好的使用时间) 使用条件: 参阅本手册“规范”部分规定的环境条件。

电池 EFUP: 5 年

## China RoHS Compliance (English Version)

| Part Name                      | Toxic or Hazardous Substances and Elements |              |              |   |                                |                                       |
|--------------------------------|--|--------------|--------------|---|--------------------------------|---------------------------------------|
|                                | Lead (Pb)                                  | Mercury (Hg) | Cadmium (Cd) | Hexavalent Chromium (Cr <sup>6+</sup> ) | Polybrominated Biphenyls (PBB) | Polybrominated Diphenyl Ethers (PBDE) |
| PCBAs                          | X  | 0            | X            | X                                       | X                              | X                                     |
| Mechanical Hardware            | 0  | 0            | X            | 0                                       | 0                              | 0                                     |
| Sheet Metal                    | 0  | 0            | X            | 0                                       | 0                              | 0                                     |
| Plastic Parts                  | 0  | 0            | 0            | 0                                       | X                              | X                                     |
| Cable Assemblies               | X  | 0            | X            | 0                                       | X                              | X                                     |
| Display                        | X  | 0            | X            | X                                       | X                              | X                                     |
| Power Supply                   | X  | X            | X            | 0                                       | X                              | X                                     |
| Fans                           | X  | 0            | X            | 0                                       | X                              | X                                     |
| Battery for Processor          | X  | 0            | X            | 0                                       | 0                              | 0                                     |
| Power Cord                     | X  | 0            | X            | 0                                       | X                              | X                                     |
| Ext Power Supply (if present)  | X  | X            | X            | 0                                       | X                              | X                                     |
| Probes (if present)            | X  | 0            | X            | 0                                       | X                              | X                                     |
| CD Drive (if present)          | X  | 0            | X            | 0                                       | X                              | X                                     |
| Fuse (if present)              | X  | 0            | X            | 0                                       | 0                              | 0                                     |
| Product Case (if present)      | 0  | 0            | 0            | 0                                       | X                              | X                                     |
| Adapters/ Modules (if present) | X  | 0            | 0            | 0                                       | 0                              | 0                                     |
| Mouse (if present)             | X  | 0            | X            | 0                                       | X                              | X                                     |

**PLEASE NOTE THE FOLLOWING:**

- **O:** Indicates that this toxic or hazardous substance contained in all of the homogeneous materials for this part is below the limit requirement specified in SJ/T11363-2006.
- **X:** Indicates that this toxic or hazardous substance contained in at least one of the homogenous materials used for this part is above the limit requirement specified in SJ/T11363-2006.
- **EFUP (Environmental Friendly Use Period) Use Conditions:** Refer to the environmental conditions stated in the specifications section of this Manual.
- **EFUP for Battery:** 5 Years

### Contact LeCroy for Support

Use the following regional contacts to find the appropriate support location nearest you.

Whether you're looking for sales or technical support, our staff can provide assistance with any of your installation, calibration, and overall product needs.

## WaveStation

You can also find contact information for our offices on the LeCroy Web sites shown for the following regions:

### Contact Your Local LeCroy Office for Sales and Technical Assistance

#### ***United States and Canada - World Wide Corporate Office***

LeCroy Corporation  
700 Chestnut Ridge Road  
Chestnut Ridge, NY, 10977-6499

**Phone (Sales, Applications, and Service):** 800-553-2769 (options 1, 2, and 3, respectively)  
or 845-425-2000

**Fax (Sales, Applications, and Service):** 845-578-5985

**Email (Sales, Applications, and Service):** [contact.corp@lecroy.com](mailto:contact.corp@lecroy.com)

**Web Site:** [www.lecroy.com](http://www.lecroy.com)

#### ***United States - Protocol Solutions Group***

LeCroy Corporation  
3385 Scott Boulevard  
Santa Clara, CA, 95054

**Phone (Sales and Service):** 800-909-7211 or  
408-727-6600

**Phone (Support):** 800-909-7112 or 408-653-  
1260

**Fax (Sales, Service, and Support):** 408-727-  
0800

**Email (Sales and Service):**

[contact.corp@lecroy.com](mailto:contact.corp@lecroy.com)

**Email (Support):** [pggsupport@lecroy.com](mailto:pggsupport@lecroy.com)

**Web Site:** [www.lecroy.com](http://www.lecroy.com)

#### ***European Headquarters***

LeCroy Europe  
4, Rue Moïse Marcinhes  
Case postale 341  
1217 Meyrin 1  
Geneva

**Phone (Sales, Service, and Support):** + 41  
22 719 2228, +41 22 719 23 23, and +41 22  
719 22 77 use +44(1276)503 971 for  
Protocol Analyzers

**Fax (Sales and Service):** +41 22 719 22 33

**Email (Sales, Service, and Support):**

[contact.sa@lecroy.com](mailto:contact.sa@lecroy.com),

[samir.shafik@lecroy.com](mailto:samir.shafik@lecroy.com), and

[applications.indirect@lecroy.com](mailto:applications.indirect@lecroy.com)

**Web Site:** <http://www.lecroy.com/europe>

#### ***China***

LeCroy Corporation Beijing Office and Service  
Center

Rm. 2001 - Office; Rm. 2002 - Service Center  
Unit A, Horizon Plaza

No. 6, Zhichun Road, Haidian District  
Beijing 100088,  
China

**Phone:** ++86 10 8280 0318 / 0319 / 0320

**Phone Service:** ++86 10 8280 0245

**Fax (Sales and Support):** +86 10 8280 0316

**Web Site:** <http://www.lecroy.com.cn>

#### ***Korea - Seoul***

LeCroy Korea  
10th fl. Ildong Bldg.

968-5 Daechi-dong, Gangnam-gu  
Seoul 135-280, Korea

**Phone (Sales and Support):** ++ 82 2 3452  
0400

**Fax (Sales and Support):** ++ 82 2 3452 0490

**Web Site:** <http://www.lecroy.co.kr>

#### ***Singapore (Oscilloscopes)***

#### ***Singapore (Protocol Analyzers)***

## Contact Your Local LeCroy Office for Sales and Technical Assistance

LeCroy Singapore Pte Ltd  
Blk 750C Chai Chee Road #02-08  
Technopark@ Chai Chee  
Singapore 469003

**Phone (Sales and Support):** ++ 65 64424880  
**Fax (Sales and Support):** ++ 65 64427811

Genetron Singapore Pte Ltd  
37 Kallang Pudding Road, #08-08  
Tong Lee Building Block B  
Singapore 349315

**Phone (Sales and Support):** ++ 65 9760-4682

### *Taiwan*

LeColn Technology Co Ltd  
Far East Century Park, C3, 9F,  
No. 2, Chien-8th Road,  
Chung-Ho City,  
Taipei Hsien,  
Taiwan, R.O.C.

**Phone (Sales and Support):** ++ 886 2 8226 1366

**Fax (Sales and Support):** ++ 886 2 8226 1368

**Email (Sales):** [sales\\_twn@lecoln.com.tw](mailto:sales_twn@lecoln.com.tw)

**Web Site:** <http://www.lecoln.com.tw>

### *Tokyo*

LeCroy Japan  
Hobunsya Funchu Bldg, 3F  
3-11-5, Midori-cho, Fuchu-Shi  
Tokyo, 183-0006  
Japan

**Phone (Sales and Support):** ++ 81 4 2402 9400

**Fax (Sales and Support):** ++ 81 4 2402 9586

**Web Site:** [www.lecroy.com/japan](http://www.lecroy.com/japan)

## Index

### A

Adjusting the Handle, 12  
Amplitude/HLevel, 29

### B

Back Panel, 14

### C

Combined Use of Waveform,  
Function, and Configuration  
Buttons, 23  
Common Burst Waveform Menu  
Controls and Considerations, 52  
Common Save/Recall Menu  
Controls and Considerations, 57,  
62  
Common Sweep Waveform  
Controls and Considerations, 48  
Connecting Your Adapter, 77  
Controlling WaveStation with  
USB-GPIB and/or USBTMC, 76  
Creating a Noise Wave, 36  
Creating a Pulse Wave, 34  
Creating a Ramp Wave, 33  
Creating a Sine Wave, 28  
Creating a Square Wave, 31

Creating an Arbitrary Waveform,  
37  
Creating Waveforms Overview,  
27

### D

Delay, 36  
Digital Input Front Panel  
Controls, 27  
Duty Cycle, 32

### F

Frequency/Period, 28  
Front Panel, 13

### G

Generating a FM (Frequency  
Modulation) Modulated  
Waveform, 42  
Generating an AM (Amplitude  
Modulation) Modulated  
Waveform, 41  
Generating an ASK (Amplitude  
Shift Keying Modulation)  
Modulated Waveform, 43  
Generating an FSK (Frequency  
Shift Keying Modulation)  
Modulated Waveform, 45

Generating an PM (Phase Modulation) Modulated Waveform, 46  
Generating Burst Waveforms, 51  
Generating Sweep Waveforms, 47

## I

Initial Function Settings, 22  
Installing the WaveStation PC Drivers and Software, 79

## L

Load Wform, 38

## M

Main Save/Recall Operations, 57  
Main Utility Operations, 62  
Making the WaveStation - PC Software Connection, 80  
Memory Banks, 59, 60  
Modifying Waveform Files from PC Software to WaveStation, 84  
Modifying Waveform Files from WaveStation to PC Software, 81

## N

Navigating Interfaces, Adjusting Parameters, and Making Selections, 16

## O

Offset/LLevel, 30  
Operation Menu Selections and Parameters, 58

## P

Phase/EqPhase, 31  
PulWidth/Duty, 35

## R

Restoring the Default Settings, 73

## S

Save/Recall Overview, 56  
Save/Recall, Utility, and Help Buttons, 23  
Specifications, 88  
Symmetry, 34

## T

technical support, 92

# WaveStation

---

The USB-GPIB Adapter, 76

The WaveStation Interface, 15

## U

Using WaveStation Help, 75

Utility Operation Menu  
Selections and Parameters, 63

## V

Variance/Mean, 37

## W

Waveform Signal Conditioning  
Buttons, 22

Waveform Types and Default  
Parameters, 21

WaveStation PC Software  
Overview, 78

Welcome, 6

**Thank you for purchasing a  
WaveStation  
Function/ Arbitrary Waveform  
Generator.**

**LeCroy**

Corporate Headquarters  
700 Chestnut Ridge Road  
Chestnut Ridge, NY 10977  
USA

[www.lecroy.com](http://www.lecroy.com)