



GE
Lighting

9
kWh/1000h

A+
energy class

67
lumens/watt



Biax™ S/E 4-pin, External Starter Req.

F9BX/827/4P 2G7 MIH

37710

Product information

Biax™ S compact fluorescent lamps can provide savings of up to 73% in energy costs compared to incandescent lamps. Available in 5, 7, 9 and 11 watt ratings, low wattage Biax™ S lamps are ideal for new installations or to replace existing incandescent lamps. These lamps are available in 2700, 3000, 3500, 4000, 5000 and 6500K colour temperatures. The Biax™ S lamps have built-in internal starters. They have a rated average life of 10,000 hours, which results in fewer lamp changes and a reduction in maintenance costs over the life of an installation.

The Biax™ S/E lamps are available in 5, 7, 9 and 11 watt ratings. However, the Biax™ S/E lamps have 4-pin caps without built-in capacitors and starters, they are therefore suitable for operation with electronic control gear and can be used for dimming and emergency lighting applications. Biax™ S/E lamps have the same energy saving benefits and high quality colour rendering as the Biax™ S range. The use of separate electronic ballasts makes them suitable for almost every kind of energy supply: high and low voltages, accumulators, batteries, solar cells and systems that

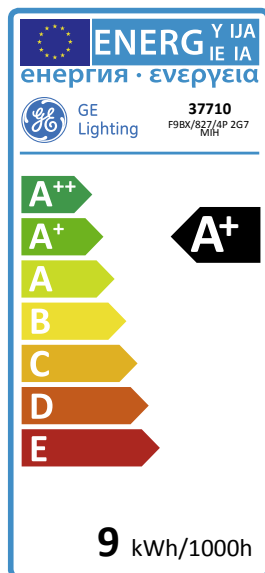

can be dimmed. When the new fluorescent lamp is installed into dimming system, it is advised to operate lamps for period of 100 hours at full light output.
Single biaxial tube (single tube with 180° bend)

Application areas



Product data

Cap/Base	2G7
Bulb Shape	Biax Plug-in
Bulb maximum overall diameter [mm]	37.5
Maximum Overall Length [mm]	151
Net weight per piece [g]	37
Gross weight per piece [g]	51
Operating position	U - Universal
Mercury Content [mg]	3
UV radiance	exempt
Brand	General Electric (GE)

Performance data

Colour Code	827
Colour Rendering Index (CRI) [Ra]	82
Nominal correlated colour temperature (CCT) [K]	2700
Nominal lumens [lm]	600
Energy efficiency class (EEC)	A+
Rated Life [h]	10000
Weighted energy consumption [kWh/1000h]	8.8

Electrical data

Nominal power [W]	9
Nominal lamp voltage [V]	60
Operating Temperature (MIN) [°C]	-15
Starting ambient temperature range	-15
Dimming Capability	Yes

Logistic data

DUN Code	00043168377102
EAN Code	0043168377102
Pack Quantity	10
Layer quantity	800 EUR, 1000 UK
Layer quantity EUR	800
Layer quantity UK	1000
Pallet quantity EUR (PC)	4800
Pallet quantity UK (PC)	6000
Outer case size	199 x 55 x 172 (mm)
Product status	Available

Technical drawing

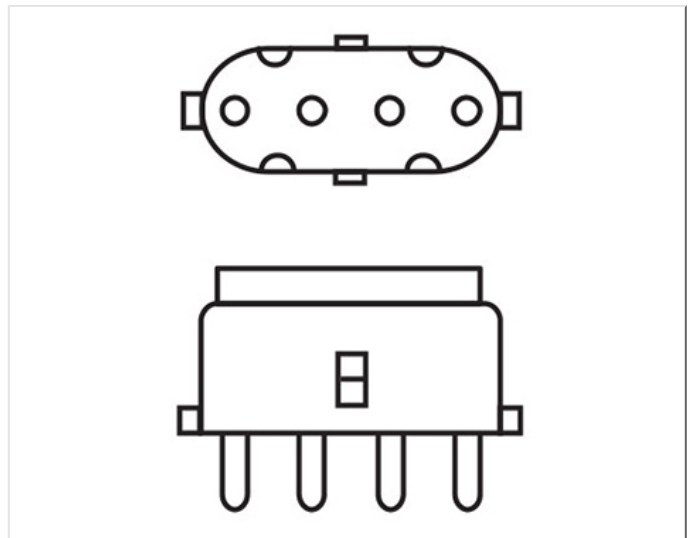
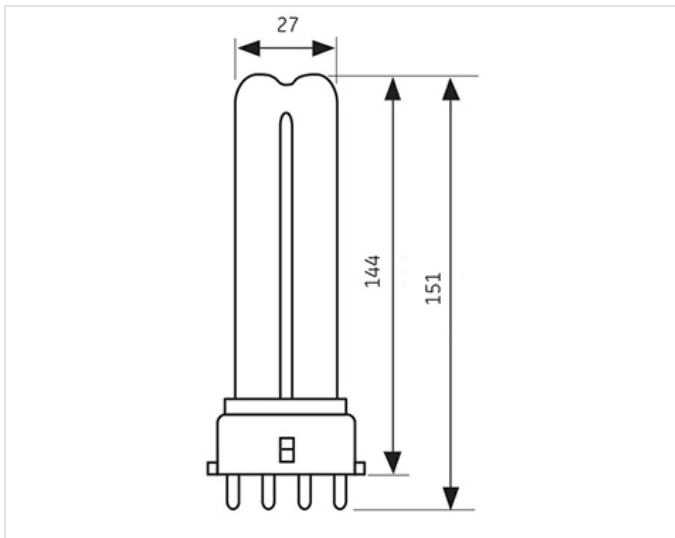

Survival data

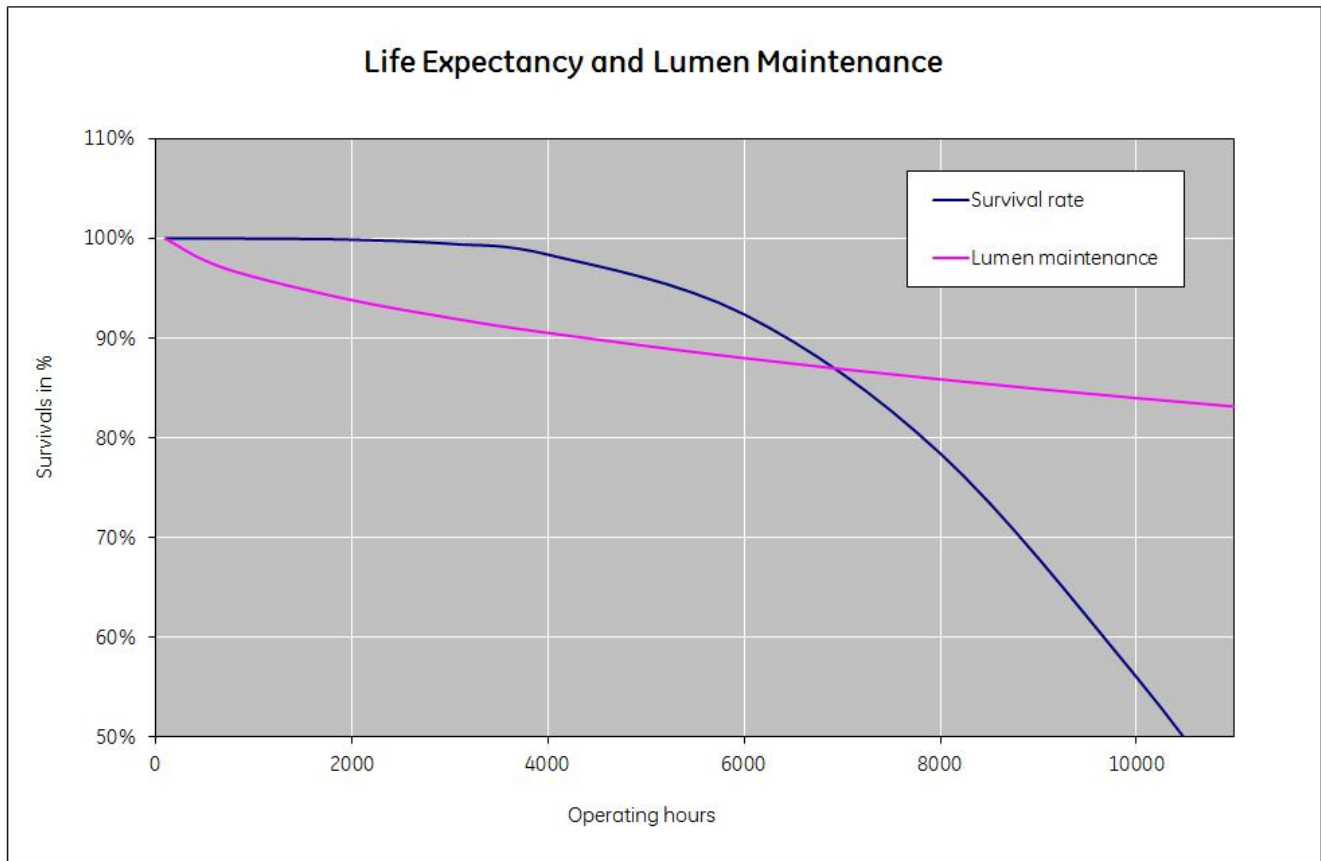

Downloads & Links

[Go to the catalog site \(HTTP\)](#)

[CFL Non-Integrated Spectrum Catalogue \(PDF\)](#)

[Longlast™ Biax™ S/E Lamps Data sheet \(PDF\)](#)

[Lighting design tools & calculators \(HTTP\)](#)

[Disposing and Cleaning of CFL Lamps \(HTTP\)](#)

[High-res images / Technical drawings \(HTTP\)](#)

[Certificate for the Quality Management System of GE Lighting EMEA \(PDF\)](#)

[Certificate for the Environmental Management System of GE Lighting EMEA \(PDF\)](#)