

Reference Specification

DHR Series
(High voltage ceramic capacitor)

Feb.08,2016

Product specifications in this drawing are subject to change or our products described in this drawing may be discontinued without advance notice.
The parts numbers are specifications listed in this drawing are for information only. You are requested to transact the "Product Specification", before your ordering.

Product Engineering Section
Product Development Department 2
Izumo Murata Manufacturing Co., Ltd.

Reference only

⚠ CAUTION

1. OPERATING VOLTAGE

When DC-rated capacitors are to be used in AC or ripple current circuits, be sure to maintain the V_{p-p} value of the applied voltage or the V_{o-p} which contains DC bias within the rated voltage range. When the voltage is started to apply to the circuit or it is stopped applying, the irregular voltage may be generated for a transit period because of resonance or switching. Be sure to use a capacitor within rated voltage containing these irregular voltage.

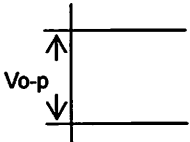
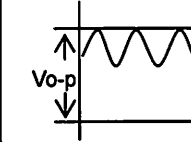
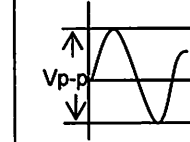
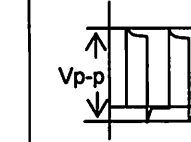
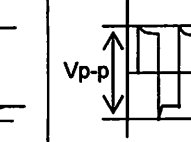
Voltage	DC Voltage	DC+AC Voltage	AC Voltage	Pulse Voltage(1)	Pulse Voltage(2)
Positional Measurement					

2. OPERATING TEMPERATURE AND SELF-GENERATED HEAT

Keep the surface temperature of a capacitor below the upper limit of its rated operating temperature range. Be sure to take into account the heat generated by the capacitor itself. When the capacitor is used in a high-frequency current, pulse current or the like, it may have the self-generated heat due to dielectric-loss. Applied voltage should be the load such as self-generated heat is within 20 °C on the condition of atmosphere temperature 25 °C. When measuring, use a thermocouple of small thermal capacity-K of $\phi 0.1\text{mm}$ and be in the condition where capacitor is not affected by radiant heat of other components and wind of surroundings.

Excessive heat may lead to deterioration of the capacitor's characteristics and reliability.(Never attempt to perform measurement with the cooling fan running. Otherwise, accurate measurement cannot be ensured.)

3. OPERATING AND STORAGE ENVIRONMENT

The insulating coating of capacitors does not form a perfect seal; therefore, do not use or store capacitors in a corrosive atmosphere, especially where chloride gas, sulfide gas, acid, alkali, salt or the like are present. And avoid exposure to moisture. The capacitor is designed to be used in the insulating media, such as epoxy resin, silicone oil, etc.. There must be 3mm or more insulating media for each direction of the capacitor. In case of cleaning, bonding, or molding this product, verify that these processes do not affect product quality by testing the performance of a cleaned, bonded or molded product in the intended equipment. Store the capacitors where the temperature and relative humidity do not exceed -10 to 40 °C and 15 to 85. Use capacitors within 6 months after delivered.

4. BONDING, RESIN MOLDING AND COATING, BOARD TO AVOID

In case of bonding, molding or coating this product, verify that these processes do not affect the quality of capacitor by testing the performance of the bonded, molded or coated product in the intended equipment.

In case of the amount of applications, dryness / hardening conditions of adhesives and molding resins containing organic solvents (ethyl acetate, methyl ethyl ketone, toluene, etc.) are unsuitable, the outer coating resin of a capacitor is damaged by the organic solvents and it may result, worst case, in a short circuit.

The variation in thickness of adhesive, molding resin or coating may cause a outer coating resin cracking and/or ceramic element cracking of a capacitor in a temperature cycling.

Resin material to hot conditions (over °C 100) was weaker to intensity. So such with board to avoid mechanical stress in this state, please handle it with care.

5. VIBRATION AND IMPACT

Do not expose a capacitor or its leads to excessive shock or vibration during use.

Reference only

6. SOLDERING

When soldering this product to a PCB/PWB, do not exceed the solder heat resistance specification of the capacitor. Subjecting this product to excessive heating could melt the internal junction solder and may result in thermal shocks that can crack the ceramic element.

When soldering capacitor with a soldering iron, it should be performed in following conditions.

Temperature of iron-tip : 400 °C max.

Soldering iron wattage : 50W max.

Soldering time : 3.5s max.

Failure to follow the above cautions may result, worst case, in a short circuit and cause fuming or partial dispersion when the product is used.

7. Limitation of Applications

Please contact us before using our products for the applications listed below which require especially high reliability for the prevention of defects which might directly cause damage to the third party's life, body or property.

- | | | |
|--|-----------------------|-----------------------------|
| ① Aircraft equipment | ② Aerospace equipment | ③ Undersea equipment |
| ④ Power plant control equipment | | ⑤ Medical equipment |
| ⑥ Transportation equipment (vehicles, trains, ships, etc.) | | ⑦ Traffic signal equipment |
| ⑧ Disaster prevention / crime prevention equipment | | ⑨ Data-processing equipment |
| ⑩ Application of similar complexity and/or reliability requirements to the applications listed in the above. | | |

NOTICE**Cleaning**

To perform ultrasonic cleaning, observe the following conditions.

Rinse bath capacity : Output of 20 watts per liter or less.

Rinsing time : 5min maximum.

Do not vibrate the PCB/PWB directly.

Excessive ultrasonic cleaning may lead to fatigue destruction of the lead wires.

Capacitance change of capacitor

• Class 1 capacitors

Capacitance might change a little depending on a surrounding temperature or an applied voltage. Please contact us if you use for the strict time constant circuit.

• Class 2 and 3 capacitors

Class 2 and 3 capacitors like temperature characteristic B, E and F have an aging characteristic, whereby the capacitor continually decreases its capacitance slightly if the capacitor leaves for a long time.. Moreover, capacitance might change greatly depending on a surrounding temperature or an applied voltage. So, it is not likely to be able to use for the time constant circuit. Please contact us if you need a detail information.

⚠ NOTE

1. Please make sure that your product has been evaluated in view of your specifications with our product being mounted to your product.
2. You are requested not to use our product deviating from the agreed specifications.

Reference only

1. Application

This specification is applied to ceramic capacitor DHR series used for in electric equipment.
DHR series is high voltage disc ceramic capacitor

2. Rating

2.1 Operating temperature

-30°C to +85°C

2.2 Part number configuration

<u>DHR</u>	<u>B5</u>	<u>AD</u>	<u>102</u>	<u>M</u>	<u>1C</u>	<u>B</u>
Series	Temperature characteristic	Rated voltage	Capacitance	Capacitance tolerance	Lead code	Packing style code

• Temperature characteristic

Code	Temperature characteristic
B5	Y5P

Please confirm detailed specification on [5. Specification and test methods].

• Rated voltage

Code	Rated voltage
AD	DC7.5kV

• Capacitance

The first two digits denote significant figures ; the last digit denotes the multiplier of 10 in pF.
ex.) In case of 102.

$$10 \times 10^2 = 1000\text{pF}$$

• Capacitance tolerance

Please refer to [4. Part number list].

• Lead code

Code	Lead style
1C	Straight long

Please refer to [4. Part number list].

Solder coated copper wire is applied for termination.

• Packing code

Code	Packing type
B	Bulk type

Reference only

3. Marking

1. Capacitance : marked with 3 figures.
2. Cap. tolerance : marked with code.
3. Temperature Characteristic : marked with code.
4. Manufacturer's identification : marked with code.
5. Rated Voltage: marked with code.

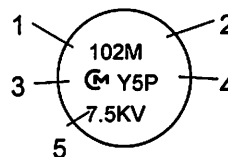

4. Part number List

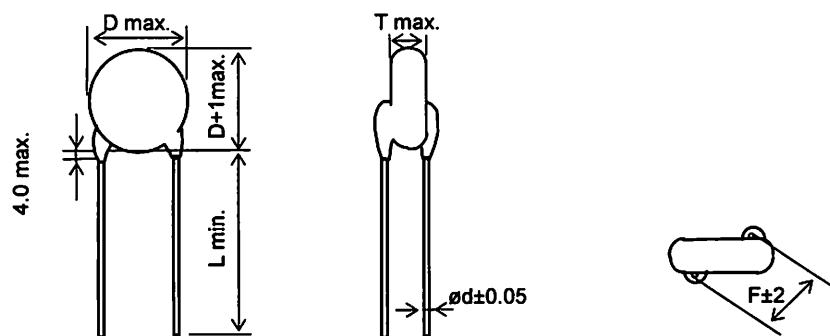

Unit:mm

Temp. Char.	Cap. (pF)	Cap. tol. (%)	Customer part number	Murata part number	DC Rated. volt. (kV)	Dimensions (mm)					Lead code	Pack qty.
						D	T	F	L	d		
Y5P	1000	±20		DHRB5AD102M1CB	7.5	15.0	7.0	9.5	25.0	0.8	1C	100

Reference only

5.TEST

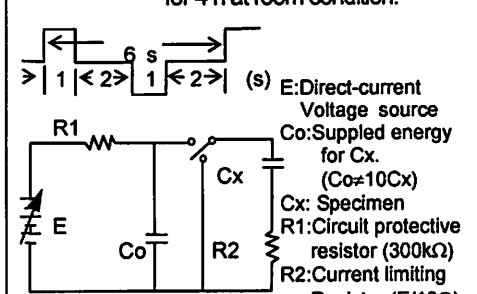
No.	ITEM		SPECIFICATION	TESTING METHOD								
1	Appearance dimensions		See 3,4.	Shall be visually examined or Venire Calipers.								
2	Marking		To be easily legible.	Shall be visually examined.								
3	Dielectric Strength	Between Lead wires	No failure	The capacitors shall not be damage when DC voltage of 150% of the rated voltage are applied between the lead wires for 60 s in insulate liquid or gas. (Charge/discharge current: 50mA max.) The capacitors is placed in the container with metal balls of diameter 1mm so that each lead wires, Short-circuited, is kept approximately 2mm off the balls as shown in the figure, and DC voltage of 3kV is applied for 10 s between capacitor lead wires and small metals. (Charge/discharge current: 50mA max.)								
		Body insulation										
4	Insulation Resistance (I.R.)	Between Lead wires	10,000MΩ min.	The insulation resistance shall be measured with DC 1kV within 60±5 s of charging.								
5	Capacitance		Within the specified tolerance.	The capacitance shall be measured at 25°C with 1±0.2kHz and AC5V(r.m.s.) max..								
6	Dissipation Factor (D.F.)		2.5% max.	Same condition as capacitance.								
7	Temperature Characteristic		Within ±10%	The capacitance measurement shall be made at each step specified in table. Capacitance change from the value of step 3 shall not exceed the limit specified.								
					<table border="1"> <tr> <td>Step Temp</td> <td>1</td> <td>2</td> <td>3</td> <td>4</td> <td>5</td> </tr> <tr> <td>Y5P</td> <td>25±2°C</td> <td>30±2°C</td> <td>25±2°C</td> <td>85±2°C</td> <td>25±2°C</td> </tr> </table>	Step Temp	1	2	3	4	5	Y5P
Step Temp	1	2	3	4	5							
Y5P	25±2°C	30±2°C	25±2°C	85±2°C	25±2°C							
8	Charge Discharge Test	Appearance	No marked defect.	Charge discharge test shall be measured in the following test circuit and cycle. Applied voltage: rated voltage Cycle numbers: 20,000 cycles Post-treatment: Capacitor shall be stored for 4 h at room condition.  E: Direct-current Voltage source Co: Supplied energy for Cx. (Co≠10Cx) Cx: Specimen R1: Circuit protective resistor (300kΩ) R2: Current limiting Resistor (E/10Ω)								
		Capacitance Change	Within ±10%									
		D.F.	4.0% max.									
		I.R.	5,000MΩ min.									
		Dielectric Strength (Between lead wires)	No failure									
9	Strength of Lead	Pull	Lead wire shall not cut off. Capacitor shall not be broken.	Fix the body of capacitor, apply a tensile weight gradually to each lead wire in the radial direction of capacitor up to 10N, and keep it for 10±1 s.								
		Bending		Each lead wire shall be subjected to 5N weight and then a 90° to bend, at the point of egress, in one direction, return to original position, and then a 90° bend in the opposite direction at the rate of one bend in 2 to 3 s.								

Note) Tests for Dielectric strength ,Charging/Discharging test, Humidity , Life and Temperature cycling shall be performed with specimens having molded resin (MR1023C:made by Murata) extending over 3mm on all the surface.

Room condition

Temperature:15~35°C

Humidity:45~75%

Atmospheric pressure:86~106kPa

Reference only

5-3 MECHANICAL PERFORMANCE TESTS

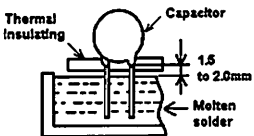
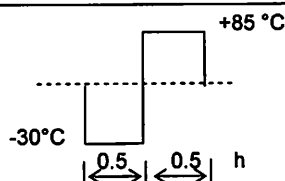
No.	ITEM	SPECIFICATION	TESTING METHOD	
10	Solderability of Leads	Lead wire shall be soldered with uniformly coated on the axial direction over 3/4 of the circumferential direction.	The lead wire shall be dipped into a 25% methanol solution of rosin and then into molten solder of $235\pm 5^{\circ}\text{C}$ for 2 ± 0.5 s. In both cases the depth of dipping is up to about 1.5 to 2.0mm from the root of lead wires. Temp. of solder : Lead Free Solder (Sn-3Ag-0.5Cu) $245\pm 5^{\circ}\text{C}$ H63 Eutectic Solder $235\pm 5^{\circ}\text{C}$	
11	Soldering effect (Non-preheat)	Appearance	No marked defect.	The lead wires shall be immersed into the melted solder of $350\pm 10^{\circ}\text{C}$ up to about 1.5 to 2.0mm from the main body for 3.5 ± 0.5 s. Post-treatment: Capacitor shall be stored for 24 ± 2 h at room condition.
		Capacitance Change	Within $\pm 10\%$	
		Dielectric Strength (Between lead wires)	No failure	
12	Soldering effect (On-preheat)	Appearance	No marked defect.	First the capacitor should be stored at $120+0/-5^{\circ}\text{C}$ for $60+0/-5$ s. Then, as in figure, the lead wires should be immersed solder of $260+0/-5^{\circ}\text{C}$ up to 1.5 to 2.0mm from the root of terminal for $7.5+0/-1$ s.  Post-treatment : Capacitor should be stored for 1 to 2 h at room condition.
		Capacitance Change	Within $\pm 10\%$	
		Dielectric Strength (Between lead wires)	Per item 3.	
13	Humidity (under steady state)	Appearance	No marked defect.	Set the capacitor for 240 ± 8 h at $40\pm 2^{\circ}\text{C}$ in 90 to 95% humidity. Post-treatment: Capacitor shall be stored for 1 to 2 h at room condition. (Charge/discharge current: 50mA max.)
		Capacitance Change	Within $\pm 10\%$	
		D.F.	4.0% max.	
		I.R.	5000M Ω min.	
		Dielectric Strength (Between lead wires)	No failure	
14	Life (high temperature load)	Appearance	No marked defect.	Apply a DC voltage of 125% of the rated voltage for $1000+48/-0$ h in silicon oil at $85\pm 2^{\circ}\text{C}$. Post-treatment: Capacitor shall be stored for 24 ± 2 h at room condition. (Charge/discharge current: 50mA max.)
		Capacitance Change	Within $\pm 10\%$	
		D.F.	4.0% max.	
		I.R.	5000M Ω min.	
		Dielectric Strength (Between lead wires)	No failure	
15	Temperature Cycling	Appearance	No marked defect.	 Temperature cycling shall be measured in the following test. Cycle numbers: 5 cycles Post-treatment: Capacitor shall be stored for 4 h at room condition.
		Capacitance Change	Within $\pm 10\%$	
		D.F.	4.0% max.	
		I.R.	5000M Ω min.	
		Dielectric Strength (Between lead wires)	No failure	

Reference only

6. Packing Specification

Packaging Styles : Bulk type
 (Packing style code : B)

$$\text{The number of packing} = \text{Packing quantity} \times n$$

The size of packing case and packing way

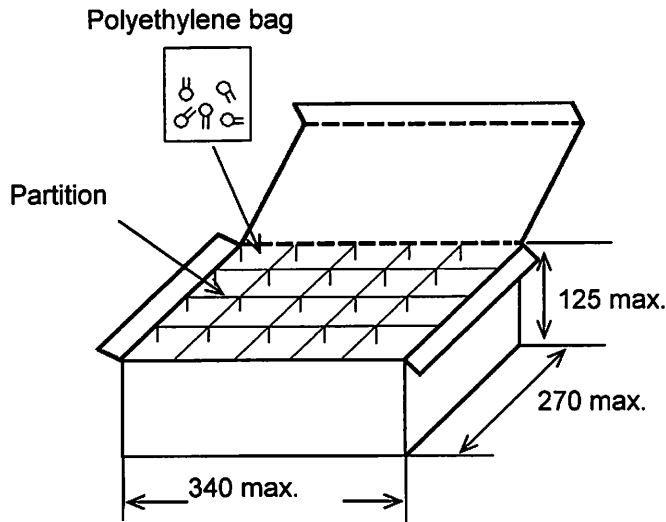

*1 : Please refer to [Part number list].

*2 : Standard n = 20 (bag)

Note)
 The outer package and the number of outer packing be changed by the order getting amount.

Unit : mm