

**770-005A1**  
**Type 1 High-Performance Elastomer**  
**90° Right Angle Lipless Shrink Boots**



Lipless 90°

**Type 1 High-Performance Elastomer Boots For Advanced Temperature And Chemical Tolerance**



Semi-rigid high performance boots combine excellent resistance to fuels, oils and solvents with superior performance at extreme temperatures. Rated for 3000 hours continuous operation at +150° C. Material meets the requirements of VG95343 Type 6, BSG 198-5-DE, EN62329-102 and SAE AS5258 Type H. 90° angled configuration aids in efficient routing of wire harnesses and cables. These boots are recommended for demanding applications such as military vehicles and petrochemical exploration. Boots come standard in black, see table below for optional colors.

- **-75° C to +150° C**
- **Excellent resistance to fuels, oils, solvents and heat.**
- **Ten available colors**

Boot Size	Part Number			
	No Adhesive Lining	Pre-Coated with W1 Hi-Temp Hot-Melt Adhesive	Pre-Coated with W2 Standard Hot-Melt Adhesive	Pre-Coated with R Epoxy Adhesive
00	<a href="#">770-005A100</a>	<a href="#">770-005A100W1</a>	<a href="#">770-005A100W2</a>	<a href="#">770-005A100R</a>
02	<a href="#">770-005A102</a>	<a href="#">770-005A102W1</a>	<a href="#">770-005A102W2</a>	<a href="#">770-005A102R</a>
03	<a href="#">770-005A103</a>	<a href="#">770-005A103W1</a>	<a href="#">770-005A103W2</a>	<a href="#">770-005A103R</a>
04	<a href="#">770-005A104</a>	<a href="#">770-005A104W1</a>	<a href="#">770-005A104W2</a>	<a href="#">770-005A104R</a>
05	<a href="#">770-005A105</a>	<a href="#">770-005A105W1</a>	<a href="#">770-005A105W2</a>	<a href="#">770-005A105R</a>
06	<a href="#">770-005A106</a>	<a href="#">770-005A106W1</a>	<a href="#">770-005A106W2</a>	<a href="#">770-005A106R</a>
07	<a href="#">770-005A107</a>	<a href="#">770-005A107W1</a>	<a href="#">770-005A107W2</a>	<a href="#">770-005A107R</a>
08	<a href="#">770-005A108</a>	<a href="#">770-005A108W1</a>	<a href="#">770-005A108W2</a>	<a href="#">770-005A108R</a>

Add "**-PP**" to the end of any part number for potting ports.

**Material Color Options for Type 1 High Performance Elastomer Only**  
**Add Optional Color Mod Code to End of Any Type 1 Material Product**

Mod Code	Color	Similar to (Reference)	Mod Code	Color	Similar to (Reference)
632 B	Blue	PANTONE 3005U	632 R	Red	PANTONE 1797U
632 E	Grey	FED-STD-595; #36270	632 T	Tan	FED-STD-595; #33446
632 G	Green	PANTONE 355U	632 W	White	FED-STD-595; #37875
632 P	Purple	FED-STD-595; #37100	632 Y	Yellow	PANTONE YELLOW U
632 O	Orange	FED-STD-595; #32300	Standard	Black	FED-STD-595; #37038

Dimensions in inches (millimeters) and are subject to change without notice.

E

## Lipless Right Angle Shrink Boots: Dimensions

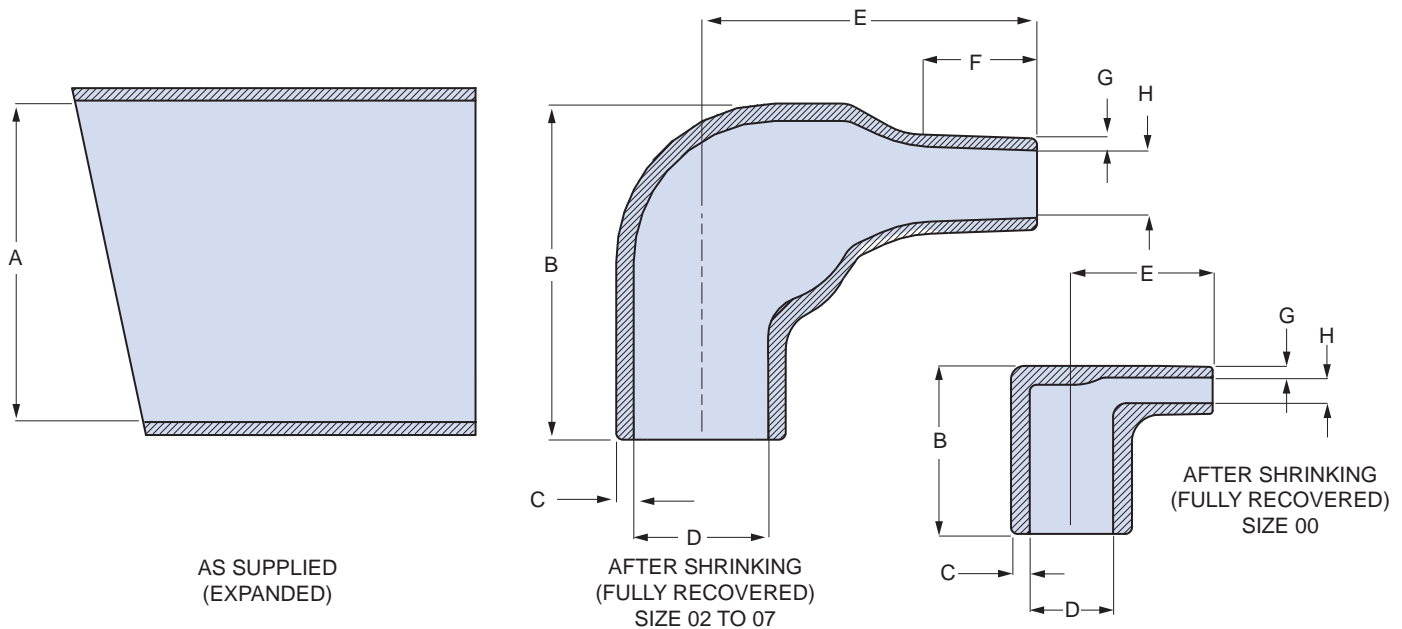

Boot Size	A Min.		B Ref.		C ±30%		D Max.		E ±20%		F Ref.		G ±20%		H Max.	
	In.	mm.	In.	mm.	In.	mm.	In.	mm.	In.	mm.	In.	mm.	In.	mm.	In.	mm.
00	.354	9.0	.492	12.5	.039	1.0	.236	6.0	.413	10.5	NA	NA	.028	0.7	.079	2.0
02	.669	17.0	.787	20.0	.051	1.3	.315	8.0	.787	20.0	.276	7.0	.028	0.7	.138	3.5
03	.945	24.0	.984	25.0	.063	1.6	.394	10.0	.984	25.0	.394	10.0	.035	0.9	.197	5.0
04	1.181	30.0	1.063	27.0	.071	1.8	.532	13.5	1.260	32.0	.472	12.0	.039	1.0	.217	5.5
05	1.260	32.0	1.260	32.0	.071	1.8	.709	18.0	1.535	39.0	.591	15.0	.047	1.2	.276	7.0
06	1.417	36.0	1.496	38.0	.079	2.0	.886	22.5	1.929	49.0	.630	16.0	.047	1.2	.335	8.5
07	1.693	43.0	1.850	47.0	.087	2.2	1.102	28.0	2.165	55.0	.709	18.0	.059	1.5	.394	10.0
08	2.050	52.0	3.150	80.0	.130	3.3	1.380	35.1	3.150	80.0	1.260	32.0	.060	1.5	1.380	35.1

## Lipless Right Angle Boots: Part Marking, Raised Lettering

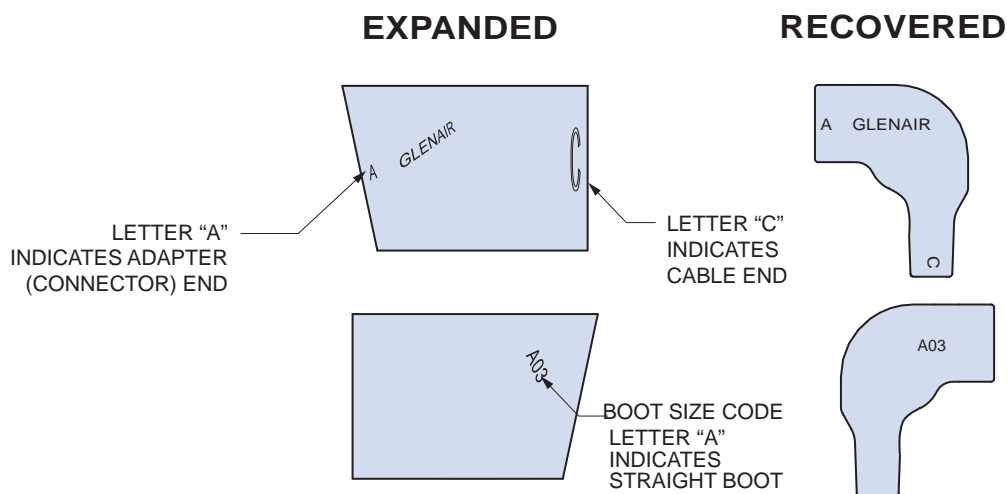

Dimensions in inches (millimeters) and are subject to change without notice.