

LED Readout  
High Precision  
Digital Pressure Switch

**Series ZSE40**  
(For vacuum /Compound pressure)

**ISE40**  
(For positive pressure)

For General Pneumatics



### High precision/High resolution

Vacuum pressure	1/1000 (0.1kPa)
Compound pressure	1/2000 (0.1kPa)
Positive pressure	1/1000 (0.001MPa)

### Compound pressure (ZSE40F)

Able to detect suction pressure (vacuum pressure) and release pressure (positive pressure) with a single pressure switch.

### 3 types of piping

Different piping methods are possible to accommodate the installation location.



### Repeatability

$\pm 0.2\%$  F.S.  $\pm 1$  digit or less

### IP65 compatible

Dust-tight/Splash proof type

## High speed response: 2.5ms or less

### With anti-chattering function

Stable switch output is possible even with sudden changes in the primary pressure (when operating large bore cylinders, etc.).

#### Anti-chattering function

Devices such as large bore cylinders and high-flow vacuum ejectors consume a large volume of air when they operate, and this may cause a momentary drop in the primary pressure. This function prevents such momentary pressure drops from being detected as abnormal pressures by allowing the response time selection to be changed.

[Selectable response times:  $t$ ]

2.5ms (normal), 24ms, 192ms or 768ms

The normal setting is selected when shipped from the factory.

(Operating principle)

The pressure values measured within the user-selected response time are averaged, and switch output (ON/OFF) is determined by comparing this averaged pressure value with the set pressure.

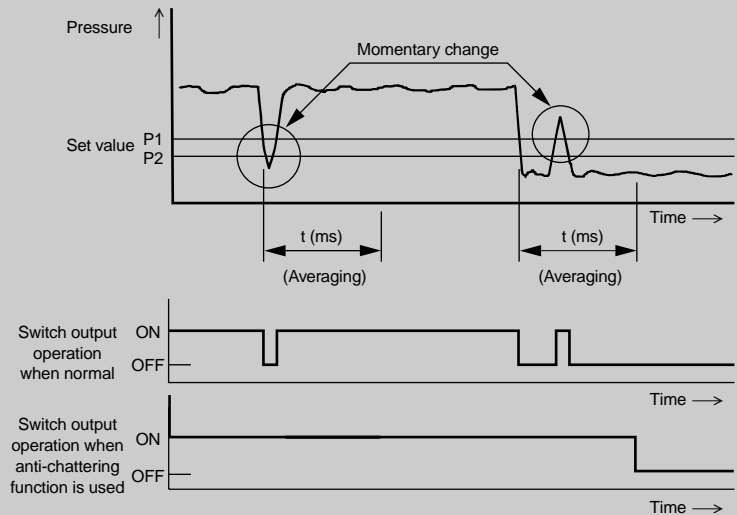

- PS
- ZSE
- ISE
- PS
- ISA
- IS
- ZSM
- PF
- IF

## With auto shift function

Allows switch output unaffected by variations in primary pressure.

### Auto shift function

Erroneous operation may occur if there is fluctuation in the primary pressure. The auto shift function compensates for pressure changes to ensure proper ON/OFF switch response during such fluctuations.

(Operating principle)

At the point when the primary pressure fluctuates, the set pressure value is compensated by setting the auto shift input (external input) to low (no-voltage) input, using the pressure measured at that point as a standard.

#### Without using auto shift

When the primary pressure fluctuates, a correct determination becomes impossible.

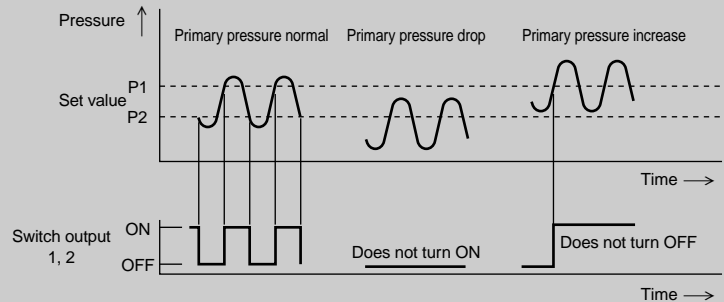

#### When using auto shift

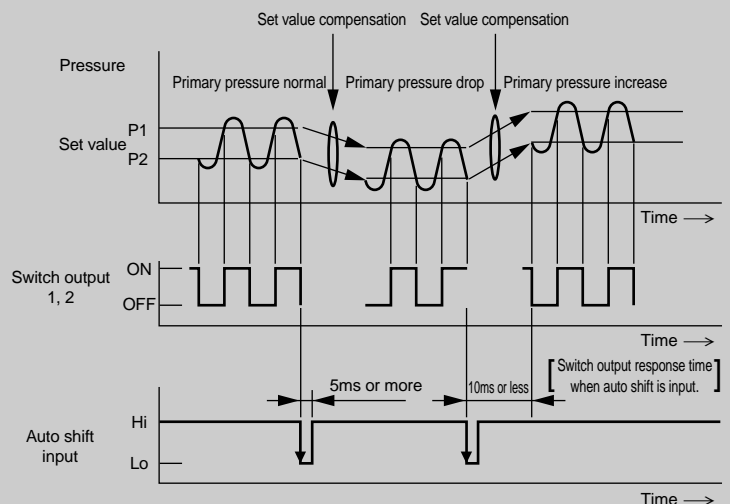

# ZSE40/ISE40

## How to Order

### Set pressure range

Nil	-0.100 to 1.000MPa	For positive pressure
-----	--------------------	-----------------------

**For Positive Pressure**

**ISE40**

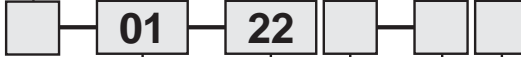

**For Vacuum/Compound Pressure**

**ZSE40**

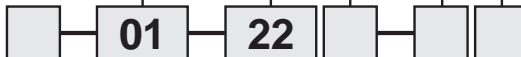

### Set pressure range

Nil	10.0 to -101.3kPa	For vacuum pressure
F	-100.0 to 100.0kPa	For compound pressure

### Piping specifications

<p><b>01:</b> R1/8 (with M5 female threads) <b>T1:</b> NPT1/8 (with M5 female threads)</p>	<p><b>W1:</b> Rc1/8 <b>WF:</b> G1/8</p> <p>Reverse pressure two directions</p>
<p>* <b>C4:</b> With ø4 One-touch fitting * <b>C6:</b> With ø6 One-touch fitting</p> <p>Wall mount</p>	<p>* <b>M5:</b> M5 (female threads)</p> <p>Wall mount</p>

\* Optional

### Input/Output specifications

<b>22</b>	NPN open collector 2 outputs + analog output
<b>30*</b>	NPN open collector 2 outputs + auto shift input
<b>62*</b>	PNP open collector 2 outputs + analog output
<b>70*</b>	PNP open collector 2 outputs + auto shift input

\* Optional

### Note

When equipped with auto shift function, the following ranges can be set.

Set pressure range	Setting range
-100.0 to 100.0kPa	-100.0 to 100.0kPa
10.0 to -101.3kPa	-101.3 to 101.3kPa
-0.1 to 1.000MPa	-1.000 to 1.000MPa

### Option

Nil	None
A	Bracket A (ZS-24-A)
B	Bracket B (ZS-24-B)
E	Panel mount (ZS-22-A) Panel Bracket (ZS-24-H)
F	Panel mount (ZS-24-C) + Front protective cover

\* When optional parts only are required, order with the part numbers inside ( ).

\*\* ZS-24-K=(ZS-22-A)+(ZS-24-H)

### Unit specifications

Nil	With unit switching function <sup>Note 1)</sup>
M	SI units only <sup>Note 2)</sup>

Note 1) This will no longer be sold for use in Japan after the new Weight and Measure Act is implemented (October, 1999).

Note 2) Fixed units  
For vacuum/compound pressure : kPa  
For positive pressure : MPa

### Lead wire length

Nil	0.6m
L	3m

# High Precision Digital Pressure Switch **ZSE40/ISE40**

## Specifications

		ZSE40F (Compound pressure)	ZSE40 (Vacuum pressure)	ISE40 (Positive pressure)
Rated pressure range		-100.0 to 100.0kPa	0.0 to -101.3kPa	0.000 to 1.000MPa
Operating pressure range/Set pressure range		-100.0 to 100.0kPa	10.0 to -101.3kPa	-0.100 to 1.000MPa
Withstand pressure		500kPa		1.5MPa
Set pressure resolution (Note 1)	kPa	0.1		—
	MPa	—		0.001
	kgf/cm <sup>2</sup>	0.001		0.01
	bar	0.001		0.01
	psi	0.02		0.1
	mmHG	1		—
InHg		0.1		—
Applicable fluid		Air, Non-corrosive/Non-flammable gas		
Power supply voltage		12 to 24VDC ±10%, Ripple (p-p) 10% or less		
Current consumption		55mA or less		
Switch output		NPN or PNP 2 outputs Max. load current : 80mA Max. applied voltage: 30VDC (with NPN output) Residual voltage : 1V or less (with 80mA load current)		
Repeatability		±0.2% F.S. ±1digit or less		
Hysteresis	Hysteresis mode	Variable		
	Window comparator mode	Fixed (3 digits) <sup>Note4</sup>		
Response time (with anti-chattering function)		2.5ms or less (with anti-chattering function: 24ms, 192ms and 768ms selections)		
Output short circuit protection		Yes		
Display		3 1/2 digit LED display (sampling cycle: 5 times/sec.)		
Display accuracy		±2% F.S. ±1 digit or less (at ambient temperature of 25 ±3°C)		
Operation indicator light		Green LED (OUT1: Lights when ON), Red LED (OUT2: Lights when ON)		
Analog output (Note 2)		Output voltage: 1 to 5V ±5% F.S. or less (in rated pressure range) Linearity: ±1% F.S. or less Output impedance: Approx. 1kΩ	Output voltage: 1 to 5V ±2.5% F.S. or less (in rated pressure range) Linearity: ±1% F.S. or less Output impedance: Approx. 1kΩ	
Auto shift input (Note 3)		No-voltage input (reed or solid state), input 5ms or more		
Environmental resistance	Enclosure	IP65		
	Ambient temperature range	Operating: 0 to 50°C, Stored: -10 to 60°C (with no condensation or freezing)		
	Ambient humidity range	Operating/Stored: 35 to 85% RH (with no condensation)		
	Withstand voltage	1000VAC for 1min. between lead wires and body		
	Insulation resistance	50MΩ or more (at 500VDC) between lead wires and body		
	Vibration resistance	10 to 500Hz at the smaller of amplitude 1.5mm or acceleration 98m/s <sup>2</sup> (10G) in X, Y, Z directions for 2hrs. each (deenergized)		
	Impact resistance	980m/s <sup>2</sup> (100G) in X, Y, Z directions 3 times each (deenergized)		
Temperature characteristics		In a temperature range of 0 to 50°C, ±2% F.S. or less of pressure measured at 25°C		
Port size		01: R1/8, M5, T1: NPT1/8, M5, W1: Rc1/8 C4: With ø4 One-touch fitting, C6: With ø6 One-touch fitting, M5: M5 female threads		
Lead wires		5 wire oil resistant heavy duty cord (0.15mm <sup>2</sup> )		
Weight		01/T1 types approx. 60g, W1 type approx. 80g, C4/C6/M5 types approx. 92g (each including 0.6m lead wires)		

- PS
- ZSE
- ISE
- PS
- ISA
- IS
- ZSM
- PF
- IF

Note 1) Equipped with unit switching function

(Types without the unit switching function use SI units (kPa or MPa) only.)

Note 2) For ZSE40 (F)/ISE40-□-<sup>22</sup>/<sub>62</sub>

Note 3) For ZSE40 (F)/ISE40-□-<sup>30</sup>/<sub>70</sub>

Note 4) For ZSE40F (compound pressure) with "psi" indication, this is 0.03 to 0.04 psi.

Note 5) For ZSE40F (compound pressure) with "psi" indication, zero clear is in the range of ±0.01 psi.

Note:

When equipped with auto shift function, the following ranges can be set.

Set pressure range	Setting range
-100.0 to 100.0kPa	-100.0 to 100.0kPa
10.0 to -101.3kPa	-101.3 to 101.3kPa
-0.1 to 1.000MPa	-1.000 to 1.000MPa

## Internal circuits and wiring examples

**ZSE40 (F)**  
**ISE40-□-22 (L)-(M)**  
With analogue output

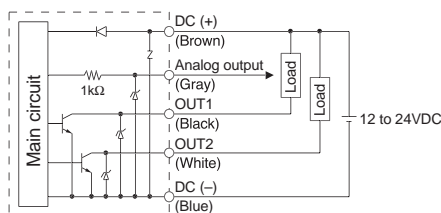

**ZSE40 (F)**  
**ISE40-□-62 (L)-(M)**  
With analogue output

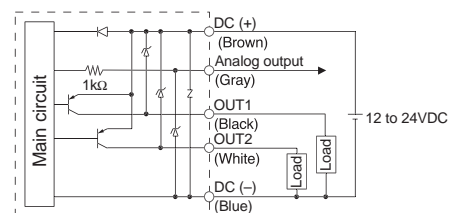

**ZSE40 (F)**  
**ISE40-□-30 (L)-(M)**  
With auto shift input

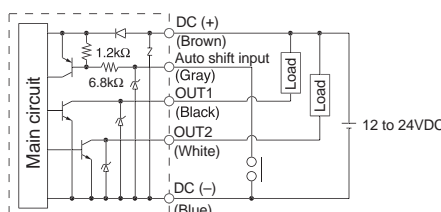

**ZSE40 (F)**  
**ISE40-□-70 (L)-(M)**  
With auto shift input

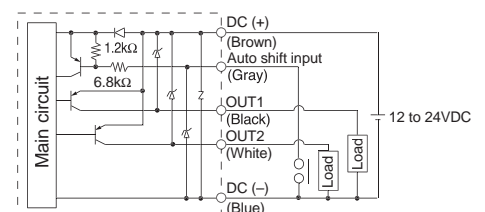



## Dimensions

ZSE40(F)/ISE40—  
C4  
 C6  
 M5



For—M5

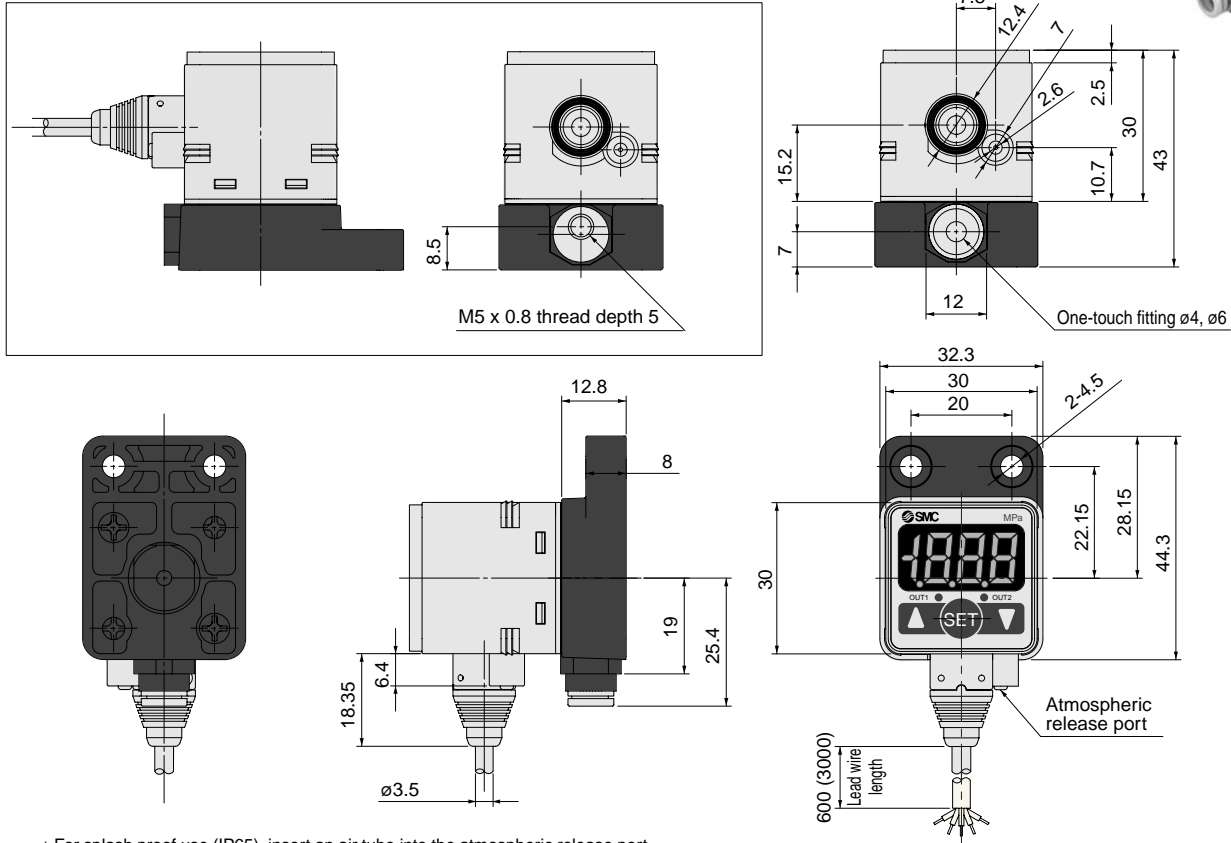

- PS
- ZSE
- ISE
- PS
- ISA
- IS
- ZSM
- PF
- IF

\* For splash proof use (IP65), insert an air tube into the atmospheric release port.

## ⚠ Specific Product Precautions

### ⚠ Caution

1. Immediately after supplying power, there is drift of about  $\pm 0.5\%$  F.S. When used with very low pressure, allow the unit to warm up for about 20 to 30 minutes.
2. Do not use in locations where there is splashing or spraying of oils and solvents.
3. When using a commercially available switching regulator, be sure to ground the FG terminal.
4. In locations where the switch is exposed to water and dust, etc., these may enter the switch from the atmospheric release port. Insert  $\varnothing 4$  tubing (inside diameter  $\varnothing 2.5$ ) into the atmospheric release port, and extend the other end to a safe area where water, etc., is not splashed or sprayed. Be sure that tubing is not bent and holes are not blocked, etc., or it will become impossible to make correct pressure measurements.

